

**150 – 1500 Mbps Cable Extender
Chipset
(DS15BA101/DS15EA101)
Evaluation Kit**

USER MANUAL

Part Number: DriveCable02EVK NOPB

For the latest documents concerning these products and evaluation kit, visit lvds.national.com. Schematics and gerber files are also available at lvds.national.com.

Table of Contents

Overview	3
Board Description.....	4
Setting Up the DriveCable02EVK Evaluation Kit	5
Evaluation with the 100-ohm Differential Balanced Cables	6
Evaluation with the 50-ohm Coaxial Cables	10

Overview

The DriveCable02EVK is an evaluation kit designed for demonstrating performance of the DS15BA101 and DS15EA101, a cable extender chipset. The kit enables evaluation of the chipset with 100-ohm differential cables such as twin-axial and low cost CAT5e/6/7 twisted pair cables and 50-ohm coaxial cables.

The purpose of this document is to: familiarize you with the DriveCable02EVK, suggest the test setup procedures and instrumentation, and guide you through some typical measurements that demonstrate performance of the chipset in typical applications.

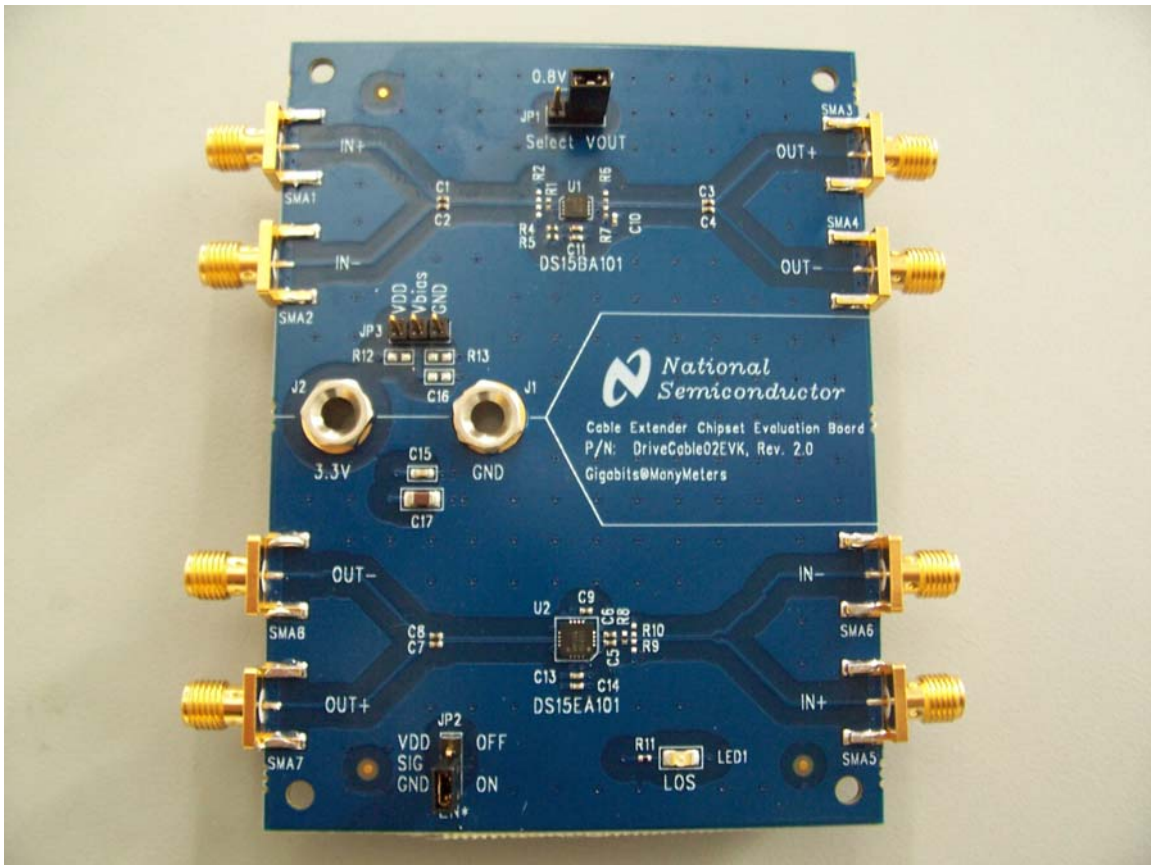

Board Description

Figure 1 shows a drawing of the board. It is a 3 inch x 4 inch 6-layer PCB with a two-device layout that is capable of demonstrating performance and all features of the DS15BA101 and DS15EA101.

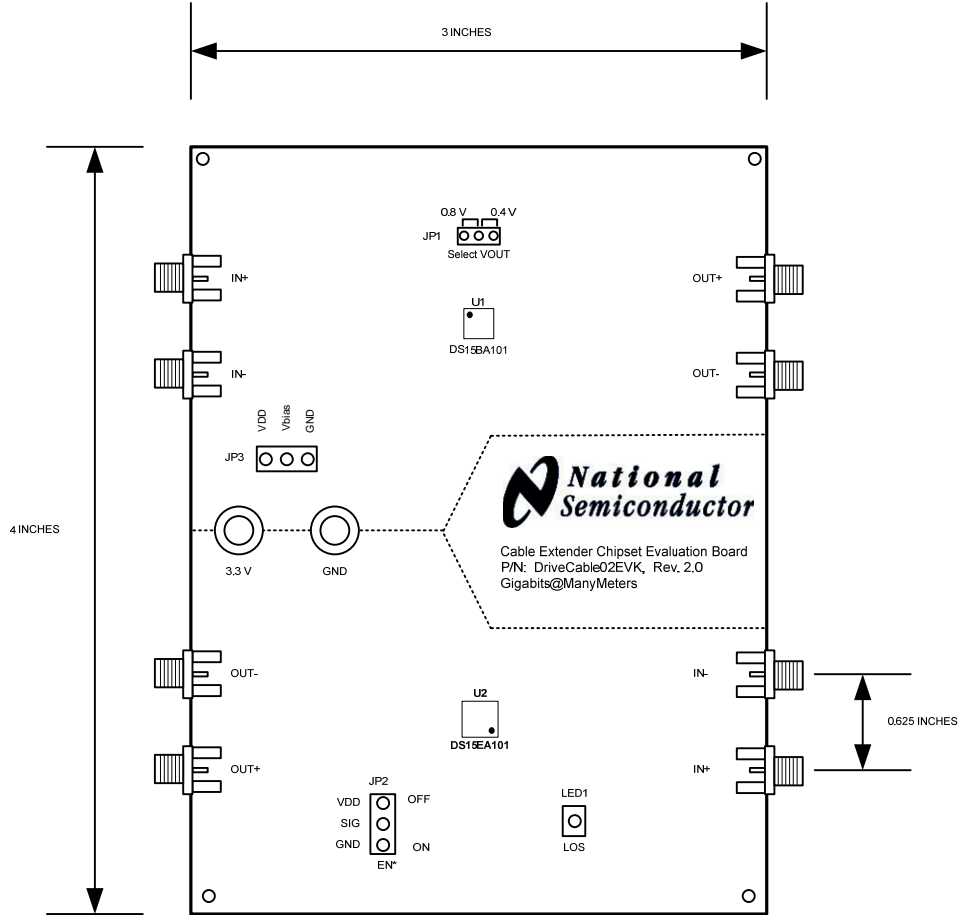

Figure 1. DriveCable02EVK Board

Connector	Device	Function
JP1	U1	Select output amplitude
JP2	U2	Output enable
JP3	U1	Set input common mode voltage (Optional)

Table 1. DriveCable02EVK Connector-Device-Function Cross Reference

Setting Up the DriveCable02EVK Evaluation Kit

This section provides a quick reference for setting up some typical test configurations using the DriveCable02EVK that will enable you to evaluate the solution with 100-ohm differential cables (twinned and twisted pair cables) as well as 50-ohm coaxial cables.

Evaluation with 100-ohm Differential Balanced Cables

The DriveCable02EVK can be used to evaluate the chipset with 100-ohm differential cables (twin-axial and twisted pair cables). Examples are CAT5e/6/7 cable assemblies such as Belden 1500A, Belden 1700A, Siemon CAT7 Tera, Belden 89207 and Amphenol SKEWCLEAR series of cables. Figure 2 is a simplified block diagram of the configuration.

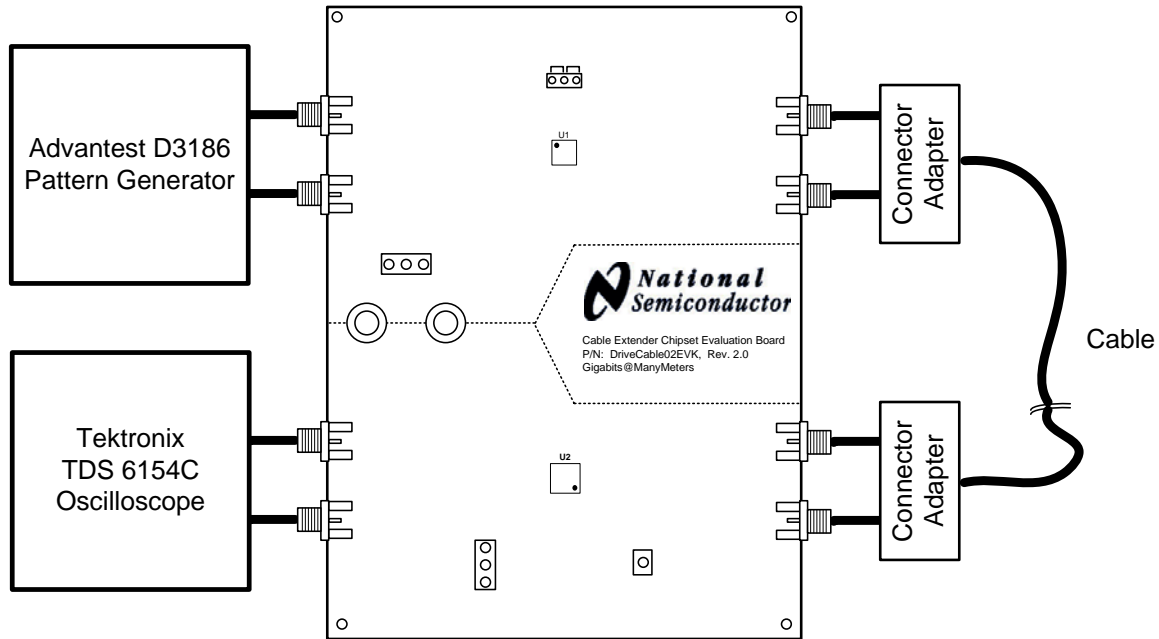

Figure 2. Test Setup for 100-ohm Differential Cable Evaluation

Note: Connector Adapters are NOT included in this kit. Currently, RJ45-SMA adapters are available and can be ordered separately. The part number is *DS91C176EVK NOPB*. If cable assemblies have other than RJ-45 connectors, it is recommended to obtain/develop an adapter board similar to the RJ45-SMA adapter to ensure good impedance control of the signal path. For more information about the RJ45-SMA Adapter check:

<http://www.national.com/appinfo/lvds/ds91c176evk.html>

Follow these steps to set up the DriveCable02EVK for evaluation with 100-ohm differential balanced cables:

1. Configure DriveCable02EVK board:
 - a) Provide 3.3 V between the J2 (VDD) and J1 (GND). This powers all devices on the board.
 - b) Set DS15BA101 (U1) output voltage amplitude to 0.4 V by using JP1.
 - c) Enable DS15EA101 (U2) outputs by setting its EN* pin to low. This is accomplished by placing a jumper across the GND and SIG pins of the connector JP2.
2. Connect the DS15BA101 inputs to a signal source (e.g. Pattern Generator or Serializer output).
 - a) Note the AC-coupling capacitors on the inputs (SMA1 and SMA2)
 - b) Adjust the signal parameters (VOH, VOL, VCM) so that they comply with the DS15BA101 input requirements.
 - c) If DC-coupled interface is desired, use 0-ohm SM0402 resistors in place of the C1 and C2.
 - d) There is a provision to add an optional resistor divider network (R12 and R13) on the DS15BA101 inputs in case one desires biasing the input signal externally (note: there is already an internal biasing network on the DS15BA101 inputs). In addition, the JP3 connector provides signal biasing provision for a voltage source.
3. Attach the connector adapters (if available) to the DS15BA101 outputs (SMA3 and SMA4) and DS15EA101 inputs (SMA5 and SMA6).
4. Connect a 100-ohm cable assembly with corresponding plugs on its ends.
5. The LED1 will illuminate if the DS15EA101 (U2) detects a valid signal.
6. Connect the DS15EA101 (U2) outputs directly to an oscilloscope, a bit error rate tester (BERT) receiver or a deserializer using good quality coaxial cables. Note that the equalizer outputs have internal 50-ohm pull-ups and that there are on-board AC-coupling capacitors.
7. Observe the results on the oscilloscope or BERT receiver.

Figure 3 presents typical maximum data rate as a function of CAT5e cable length. The data was collected on four chipsets (A, B, C and D). The data in red was taken with the 0.5 UI jitter criteria while the data in blue was taken with the 0.25 UI jitter criteria.

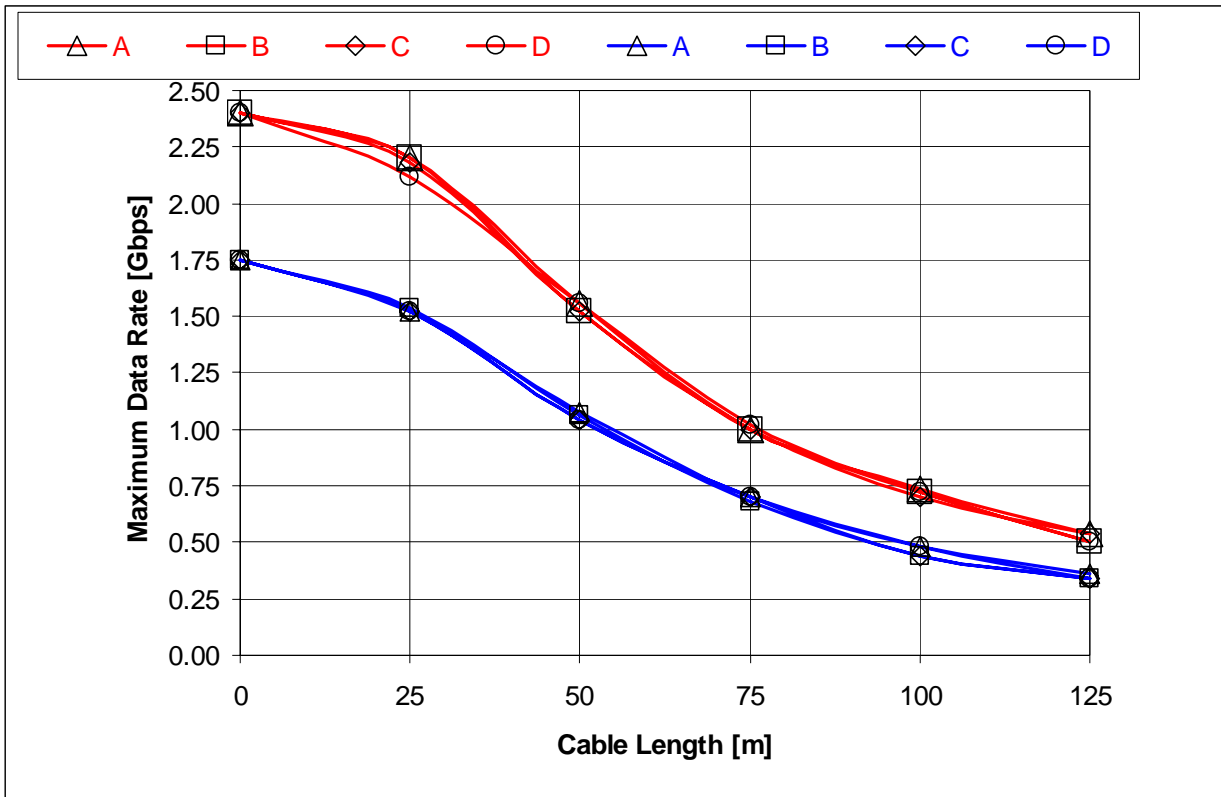

Figure 3. DS15BA101 and DS15EA101 Performance with CAT5e Cable

Figure 4 presents maximum data rate as a function of CAT7 cable length. The data was collected on four chipsets (A, B, C and D). The data in red was taken with the 0.5 UI jitter criteria while the data in blue was taken with the 0.25 UI jitter criteria.

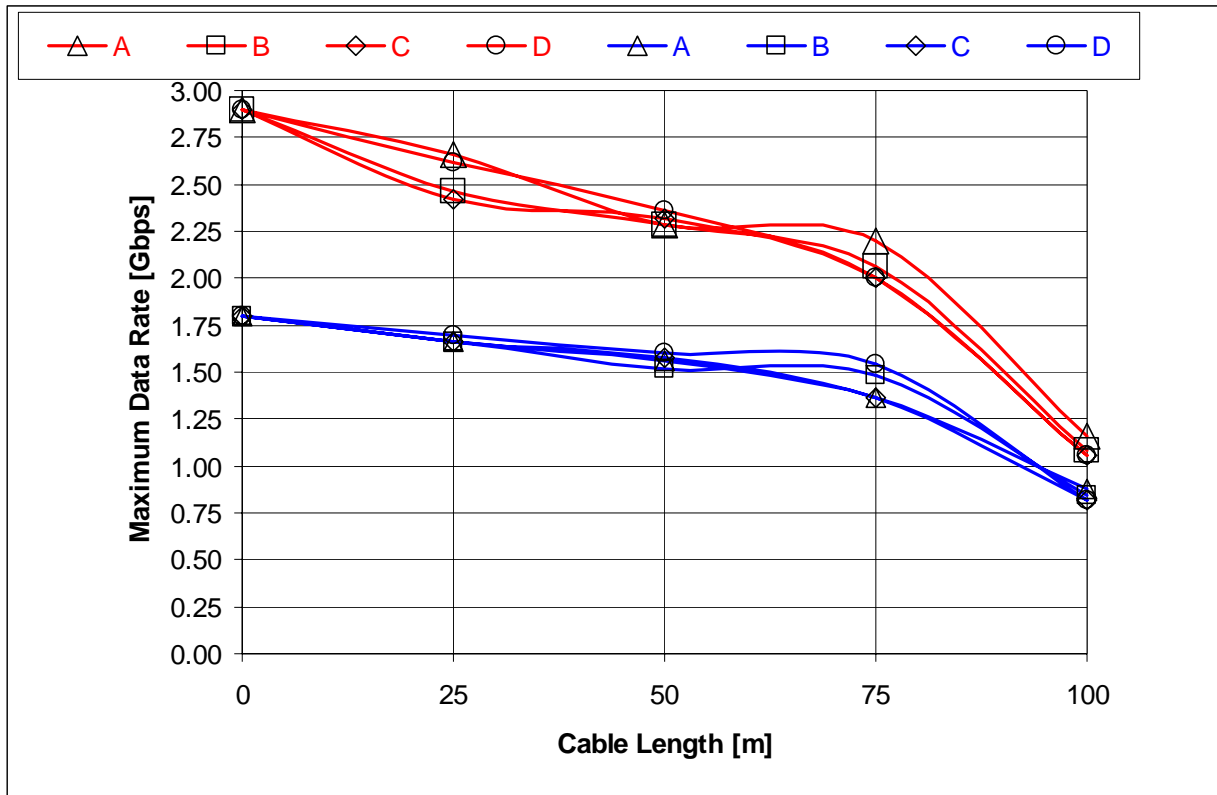

Figure 4. DS15BA101 and DS15EA101 Performance with CAT7 Cable

Evaluating 50-ohm Coaxial Cables

The DriveCable02EVK can be used to evaluate 50-ohm coaxial cables. Examples of 50-ohm coaxial cables are Belden 9914 and Andrew FSJ-50B. Figure 5 is a simplified block diagram of the configuration.

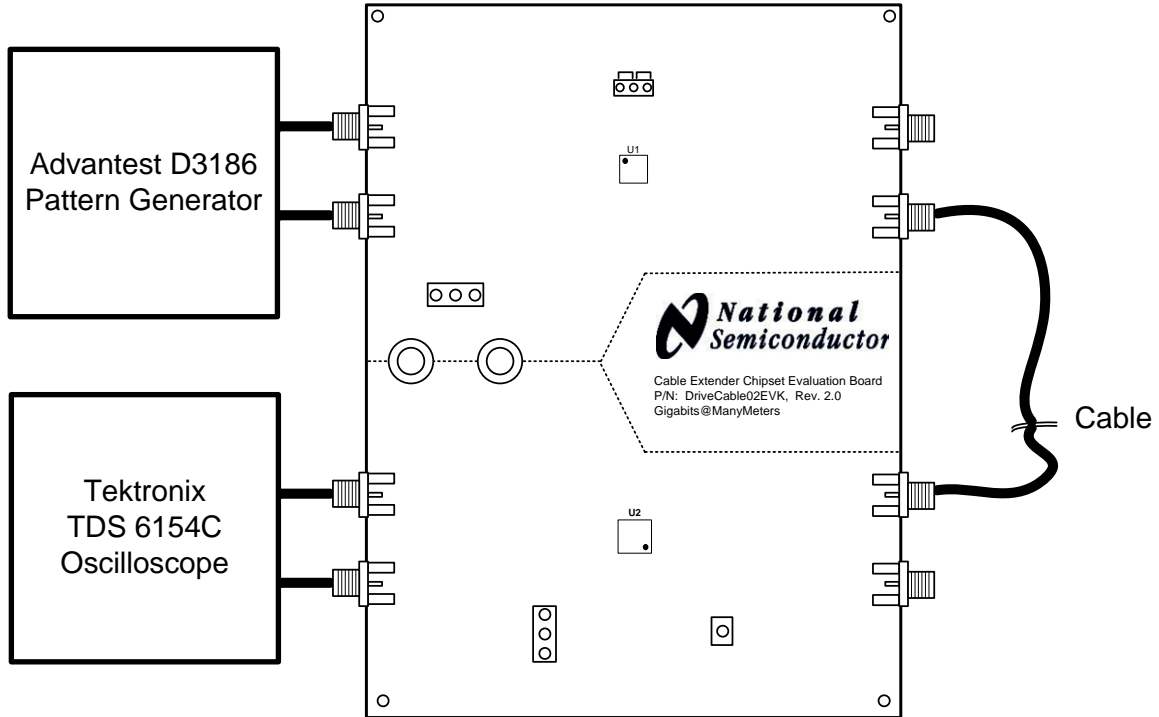

Figure 5. Test Setup for 50-ohm Coaxial Cable Evaluation

Follow these steps to set up the DriveCable02EVK for evaluation with 50-ohm coaxial cables:

1. Configure DriveCable02EVK board:
 - a) Provide 3.3 V between the J2 (VDD) and J1 (GND). This powers all devices on the board.
 - b) Set DS15BA101 (U1) output voltage amplitude to 0.8 V by using JP1.
 - c) Enable DS15EA101 (U2) outputs by setting its EN* pin to low. This is accomplished by placing a jumper across the GND and SIG pins of the connector JP2.
 - d) Remove R8 and place 50-ohm to GND termination on the DS15EA101 input that will be used (R9 or R10) and 25-ohm to GND termination on the DS15EA101 input that will NOT be used (R9 or R10).
2. Connect the cable driver inputs to a signal source (e.g. Pattern Generator).
 - e) Note the AC-coupling capacitors on the inputs (SMA1 and SMA2)
 - f) Adjust the signal parameters (VOH, VOL, VCM) so that they comply with the DS15BA101 input requirements.
 - g) If DC-coupled interface is desired, use 0-ohm SM0402 resistors in place of the C1 and C2.
 - h) There is a provision to add an optional resistor divider network (R12 and R13) on the DS15BA101 inputs in case one desires bias the signal externally (there is an internal biasing network on the DS15BA101 inputs). In addition, the JP3 connector provides signal biasing provision for a voltage source.
3. Use SMA-to-BNC Adapters (i.e. PE9074 from www.pasternack.com) if necessary (in case coaxial cable has BNC connectors).
4. Connect a coaxial cable assembly with corresponding connectors on its ends.
5. The LED1 will illuminate if the DS15EA101 (U2) detects a valid signal.
6. Connect equalizer outputs directly to an oscilloscope or a bit error rate tester (BERT) receiver using good quality coaxial cables. Note that the equalizer outputs have internal 50-ohm pull-ups and that there are on-board AC-coupling capacitors.
7. Observe the results on the oscilloscope or BERT receiver.

Figure 6 presents maximum data rate as a function of Belden 9914 cable length. The data was collected on two chipsets (A and B). The data in red was taken with the 0.5 UI jitter criteria while the data in blue was taken with the 0.25 UI jitter criteria.

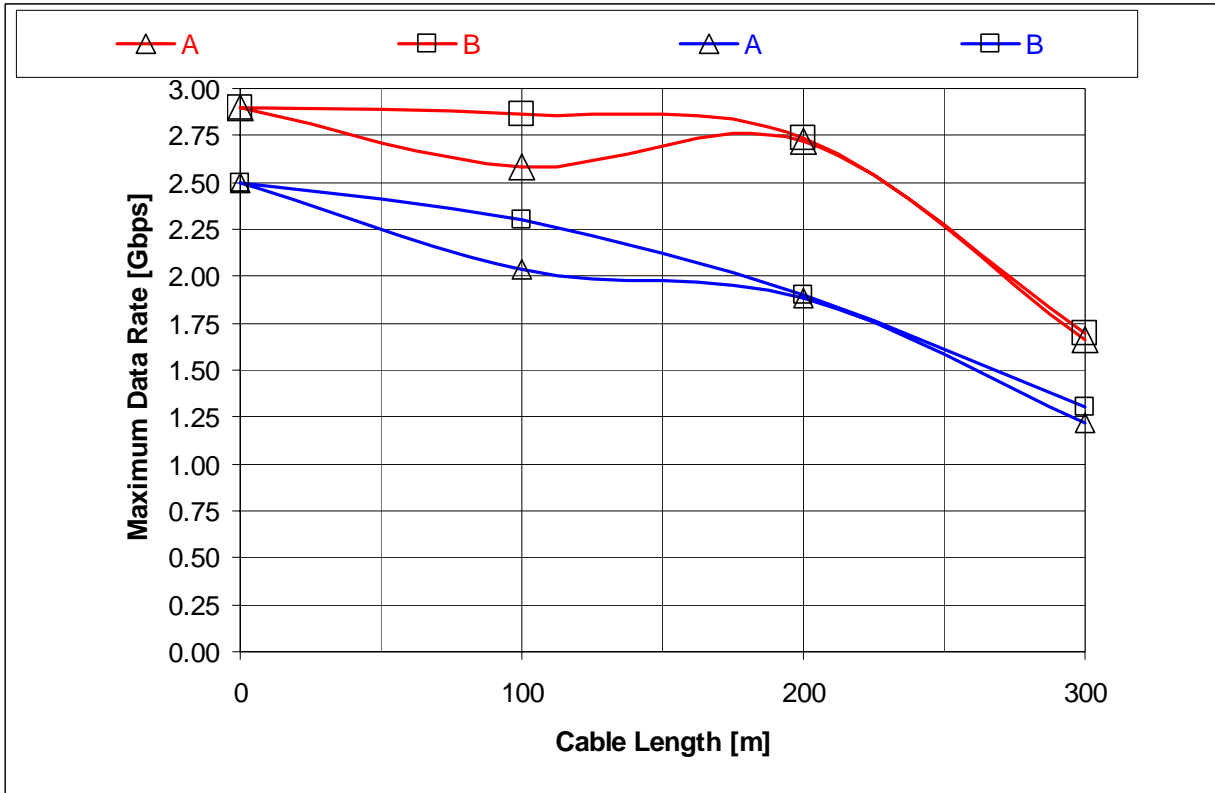

Figure 6. DS15BA101 and DS15EA101 Performance with Belden 9914 Cable

6

5

4

3

2

1

REVISION RECORD			
LTR:	ECO NO:	APPROVED:	DATE:
0	INITIAL RELEASE		

D

D

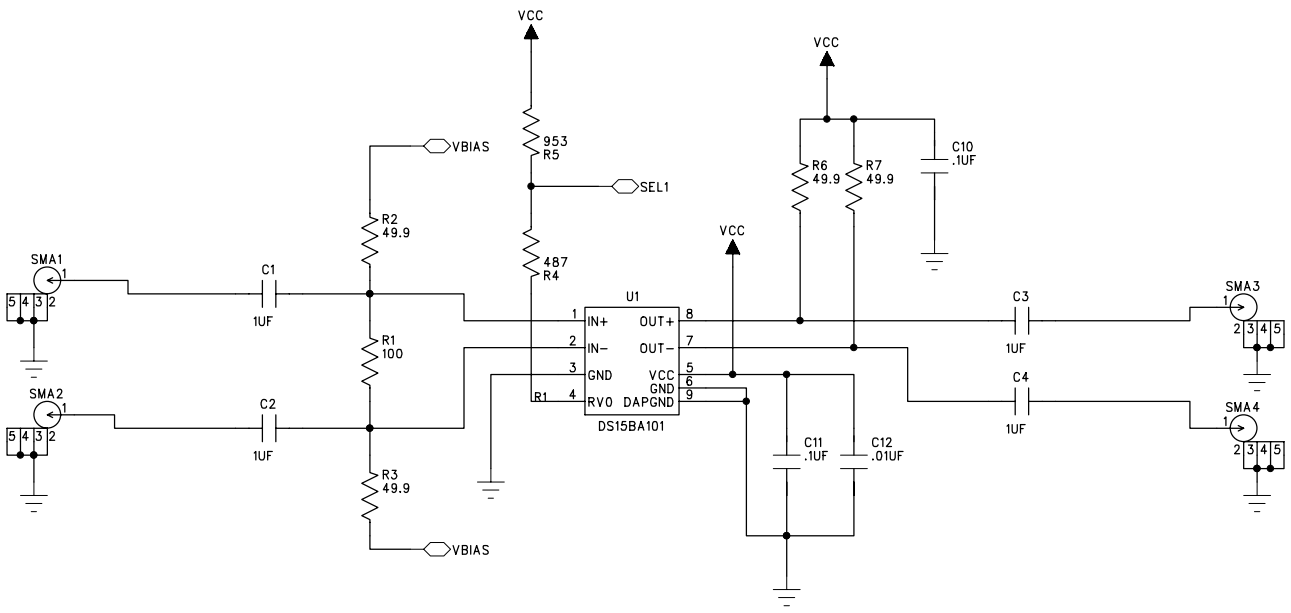

C

C

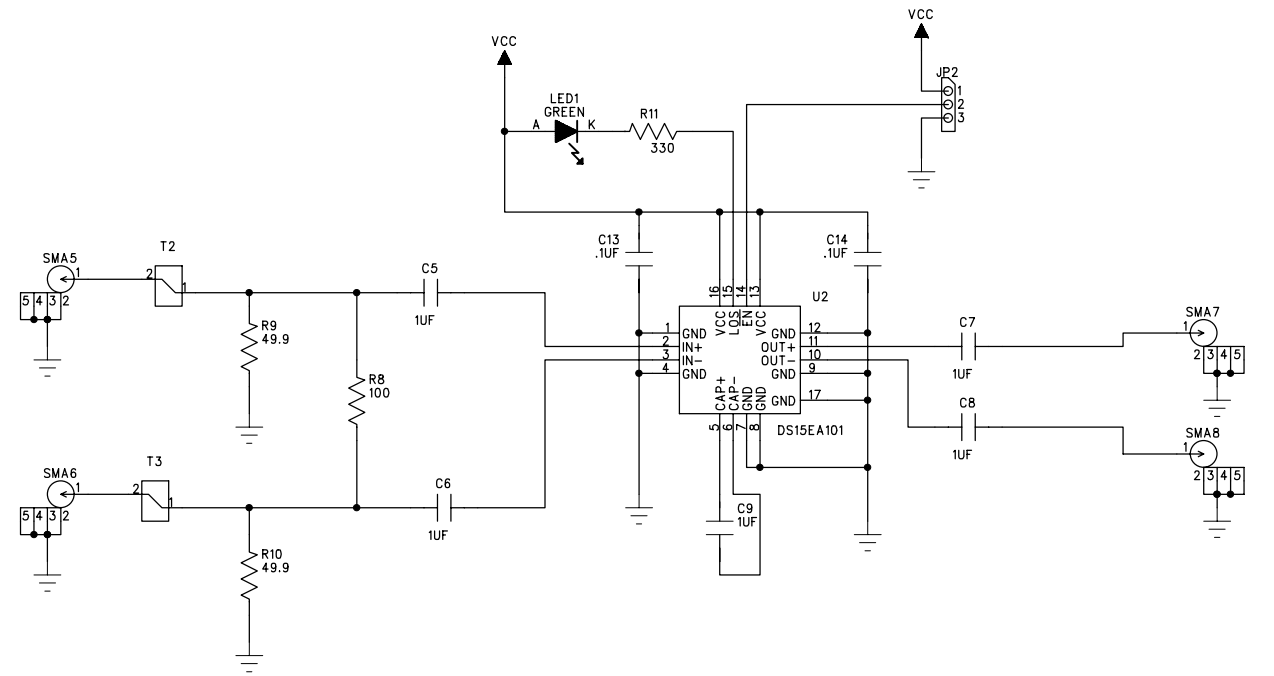

B

B

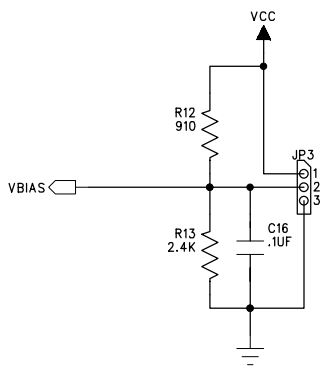
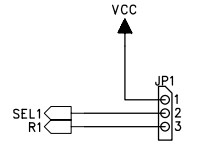
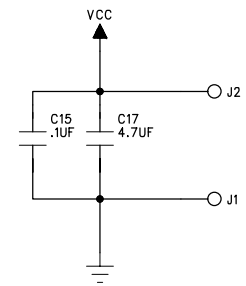

A

A

COMPANY:	NATIONAL SEMICONDUCTOR		
TITLE:	SCHEMATIC DRIVECABLE02EVK		

 25 NorthBrook Drive
 Gray, Maine 04039
 U.S.A.
 DRAWN: ACF DATED: ???
 SCALE:

CODE:	SIZE:	DRAWING NO:	REV:
	C	S-06378	0
SHEET: 1 OF 1			

ENERCON - BILL OF MATERIALS

TITLE:

**NATIONAL SEMICONDUCTOR
PCBA, DRIVECABLE02EVK, ROHS
DRIVECABLE02EVK**

 PL Number: Z3212-01
 Rev: 0
 Rev By:

Rev Date: 11/21/2007

PL Status: Preliminary

 Main Product:
 PCBA, DRIVECABLE02EVK, ROHS

Responsible Eng/Mgr:

 Creator:
 Arlene Fox

 Creation Date:
 11/21/2007

Item	Part Type	Part Number/Value	Mfg	NoSub	Description	Qty	SMT	Ref Des	Notes	Rev
1	PCB	P-06379R0	ENERCON		DRIVE: 3.00x4.00x.060in, 6 layer	1			Bd: (76.20x101.60mm) Panel: (9.20x8.00in) (233.68x203.20mm) 6 bds/panel	0
2										
3	IC	DS15BA101SD/NOPB	NAT		1.5Gpbs Diff Buffer, LLP8, Pb-Free	1	X	U1	Customer Supplied	0
4	IC	DS15EA101SQ/NOPB	NAT		0.15 to 1.5Gpbs Adaptive Cable Equal., LLP16, Pb-F	1	X	U2	Customer Supplied	0
5										
6	RES	ERJ-2RKF4991	PANA		49.9 Ohm 1/16W ±1% 0402 100ppm, Pb-Free	2	X	R6-7		0
	<ALT>	CRCW040249R9FKED	VISHAY		49.9 Ohm 1/16W ±1% 0402 100ppm, Pb-Free					
	<ALT>	RK73H1ETTP49R9F	KOA		49.9 Ohm 1/16W ±1% 0402 100ppm, Pb-Free					
7	RES	ERJ-2RKF1000	PANA		100 Ohm 1/16W ±1% 0402 100ppm, Pb-Free	2	X	R1,8		0
	<ALT>	CRCW0402100RFKED	VISHAY		100 Ohm 1/16W ±1% 0402 100ppm, Pb-Free					
	<ALT>	RK73H1ETTP1000F	KOA		100 Ohm 1/16W ±1% 0402 100ppm, Pb-Free					
8	RES	ERJ-2RKF3300	PANA		330 Ohm 1/16W ±1% 0402 100ppm, Pb-Free	1	X	R11		0
	<ALT>	CRCW0402330RFKED	VISHAY		330 Ohm 1/16W ±1% 0402 100ppm, Pb-Free					
	<ALT>	RK73H1ETTP3300F	KOA		330 Ohm 1/16W ±1% 0402 100ppm, Pb-Free					
9	RES	ERJ-2RKF4870	PANA		487 Ohm 1/16W ±1% 0402 100ppm, Pb-Free	1	X	R4		0
	<ALT>	CRCW0402487RFKED	VISHAY		487 Ohm 1/16W ±1% 0402 100ppm, Pb-Free					
	<ALT>	RK73H1ETTP4870F	KOA		487 Ohm 1/16W ±1% 0402 100ppm, Pb-Free					
10	RES	ERJ-2RKF9530	PANA		953 Ohm 1/16W ±1% 0402 100ppm, Pb-Free	1	X	R5		0
	<ALT>	CRCW0402953RFKED	VISHAY		953 Ohm 1/16W ±1% 0402 100ppm, Pb-Free					
	<ALT>	RK73H1ETTP9530F	KOA		953 Ohm 1/16W ±1% 0402 100ppm, Pb-Free					
11										
12	LED	LNJ316C8TRA	PANA		Lamp, Green, 1206, Diffused, Pb-Free	1	X	LED1		0
13										

ENERCON - BILL OF MATERIALS

TITLE:

**NATIONAL SEMICONDUCTOR
PCBA, DRIVECABLE02EVK, ROHS
DRIVECABLE02EVK**

 PL Number: Z3212-01
 Rev: 0

Rev By:

 Rev Date:
 11/21/2007

 PL Status:
 Preliminary

Main Product:

PCBA, DRIVECABLE02EVK, ROHS

Responsible Eng/Mgr:

Creator:

Arlene Fox

Creation Date:

11/21/2007

Item	Part Type	Part Number/Value	Mfg	NoSub	Description	Qty	SMT	Ref Des	Notes	Rev
14	CAP	0402YC103KAT	AVX		.01µF, 16V, ±10%, 0402, Ceramic, X7R, Pb-Free	1	X	C12		0
	<ALT>	C0402C103K4RAC	KEMET		.01µF, 16V, ±10%, 0402, Ceramic, X7R, Pb-Free					
	<ALT>	ECJ-0EB1C103K	PANA		.01µF, 16V, ±10%, 0402, Ceramic, X7R, Pb-Free					
15	CAP	0402YD104KAT	AVX		.1µF, 16V, ±10%, 0402, Ceramic, X5R, Pb-Free	4	X	C10-11,13-14		0
	<ALT>	ECJ-0EB1C104K	PANA		.1µF, 16V, ±10%, 0402, Ceramic, X5R, Pb-Free					
16	CAP	0603YC104KAT	AVX		.1µF, 16V, ±10%, 0603, Ceramic, X7R, Pb-Free	1	X	C15		0
	<ALT>	C0603C104K4RAC	KEMET		.1µF, 16V, ±10%, 0603, Ceramic, X7R, Pb-Free					
	<ALT>	ECJ-1VB1C104K	PANA		.1µF, 16V, ±10%, 0603, Ceramic, X7R, Pb-Free					
17	CAP	1206YD475KAT	AVX		4.7µF, 16V, ±10%, 1206, Ceramic, X5R	1	X	C17		0
	<ALT>	C1206C475K4PAC	KEMET		4.7µF, 16V, ±10%, 1206, Ceramic, X5R					
18	CAP	ECJ-0EB1A105M	PANA		1µF, 10V, ±20%, 0402, Ceramic, X5R, Pb-Free	9	X	C1-8,9		0
19										
20	CONN	142-0701-851	EMERSON		SMA, Jack Receptacle, 50 OHM, Pb-Free	8		SMA1-8		0
21	CONN	15-29-1024	MOLEX		Jumper Shunt, 2p, Gold, Pb-Free	2			JP1,2, Pins 2&3	0
	<ALT>	SNT-100-BK-G	SAMTEC		Shunt, .100"sp, Gold, Pb-Free					
	<ALT>	SNT-100-BK-H	SAMTEC		Shunt, .100"sp, Gold, Pb-Free					
22	CONN	3267	POMONA		Banana, 1p, Female, Pb-Free	2		J1-2		0
23	CONN	TSW-103-07-G-S	SAMTEC		Header, 3p, Male, .100"sp, Gold, Pb-Free	3		JP1-3		0
24										
25	STENCL	T-06382R0	ENERCON		STENCIL FABRICATION, DRIVECABLE02EVK	1				0
26										
27	REF	C-06380R0	ENERCON		FABRICATION DWG, DRIVECABLE02EVK					0
28	REF	C-06381R0	ENERCON		PALLET DWG, DRIVECABLE02EVK					0

ENERCON - BILL OF MATERIALS	TITLE: NATIONAL SEMICONDUCTOR PCBA, DRIVECABLE02EVK, ROHS DRIVECABLE02EVK	PL Number: Z3212-01 0	Rev: Rev By: 0	Rev Date: 11/21/2007	PL Status: Preliminary
		Responsible Eng/Mgr:	Creator: Arlene Fox	Creation Date: 11/21/2007	
Main Product: PCBA, DRIVECABLE02EVK, ROHS					

Item	Part Type	Part Number/Value	Mfg	NoSub	Description	Qty	SMT	Ref Des	Notes	Rev
29	REF	S-06378R0	ENERCON		SCHEMATIC, DRIVECABLE02EVK					0
30										

Notes:

DO NOT STUFF:
R2,3,9,10,12,13
C16

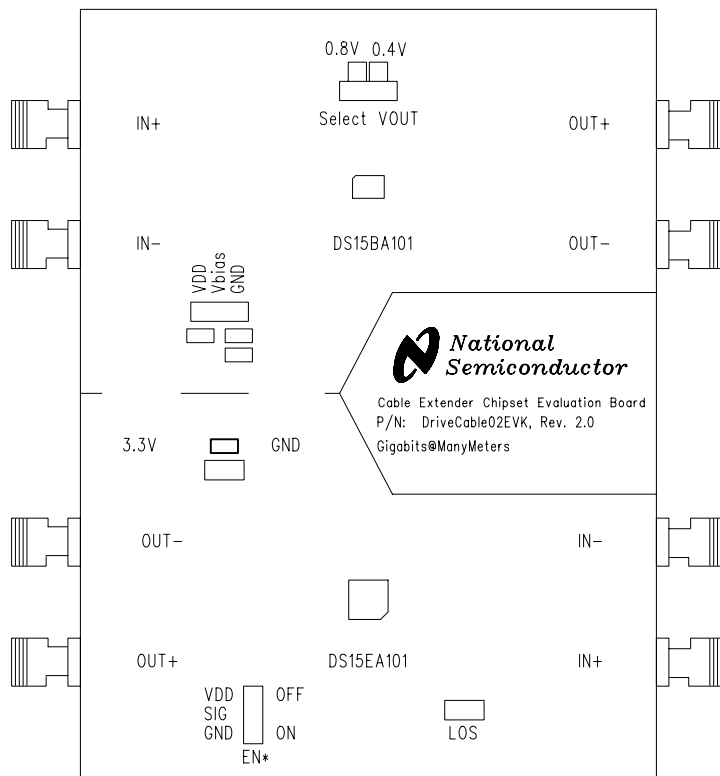

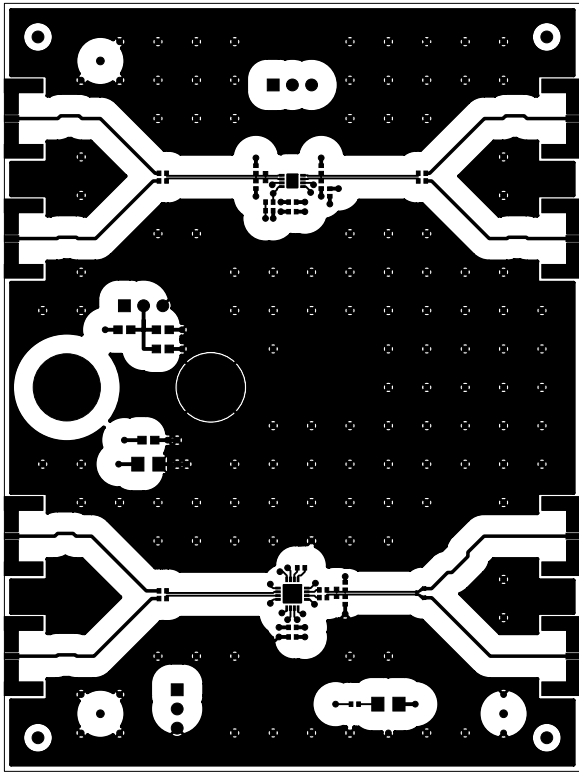

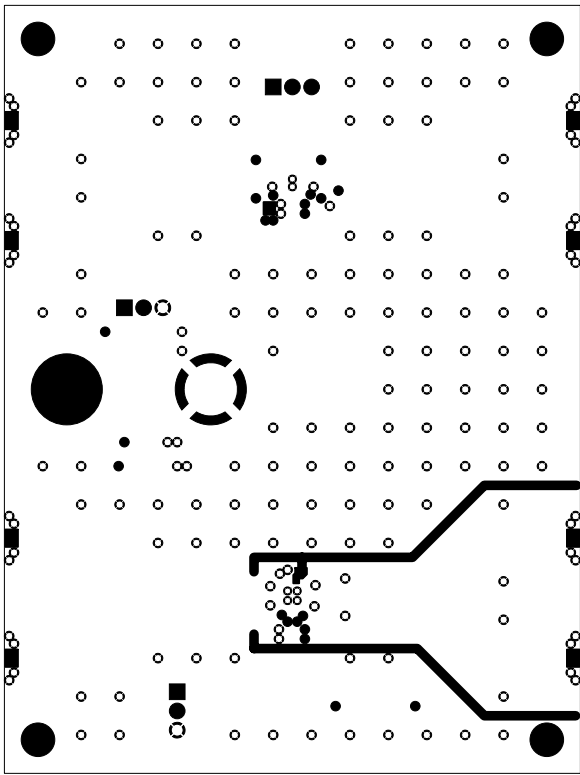

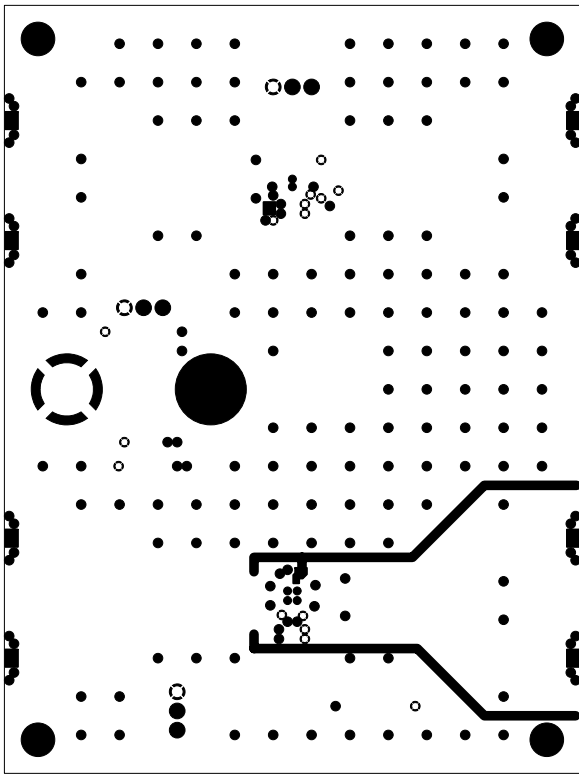

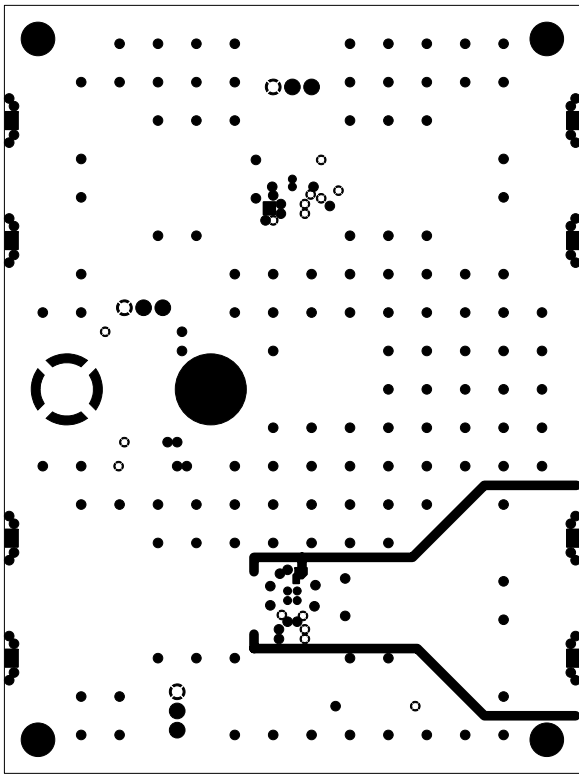

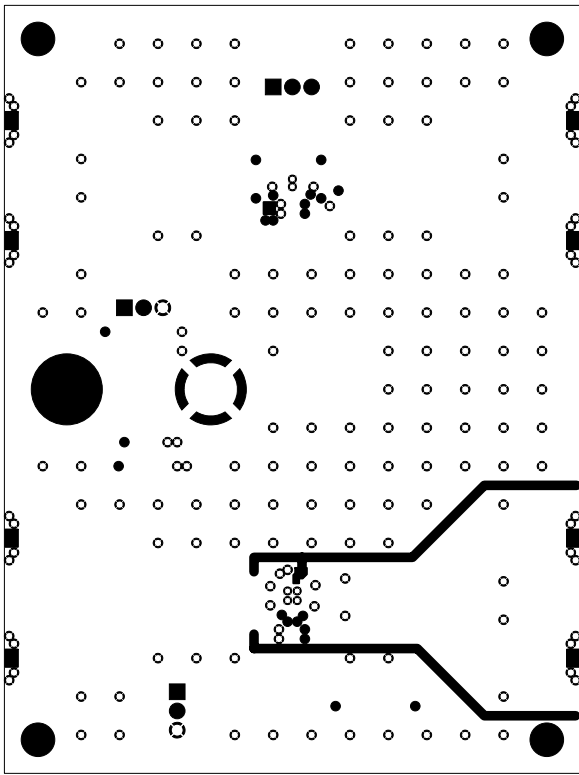

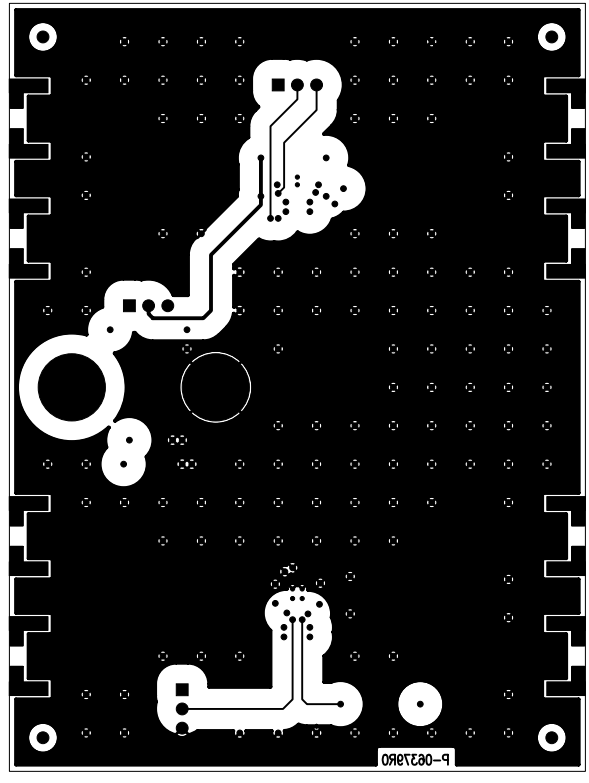

MADE IN USA
2008\02\EC
COMPLIANT
RoHS

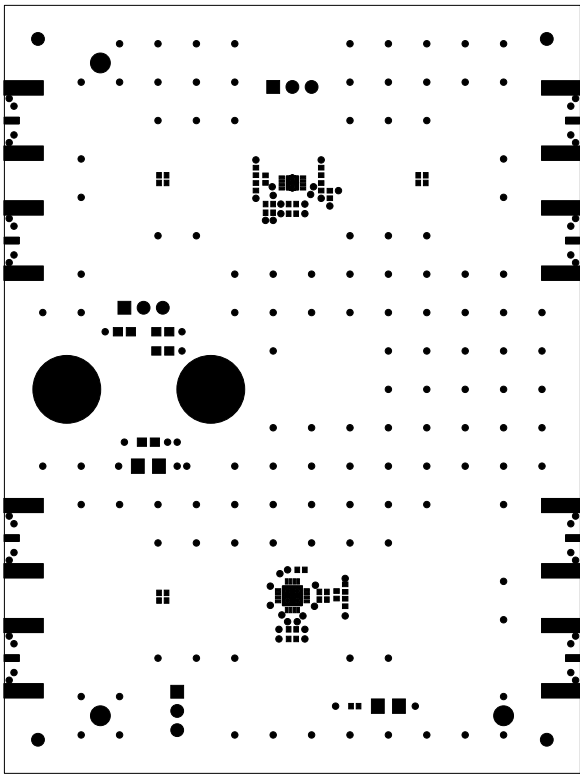

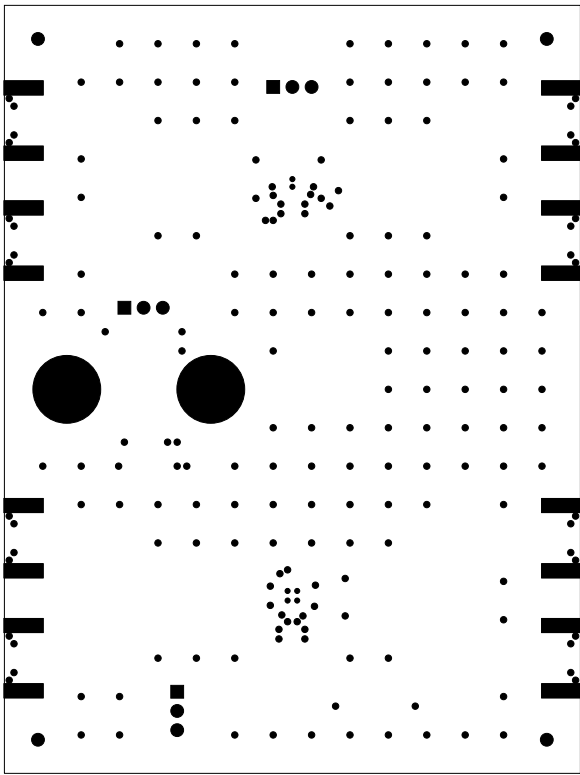

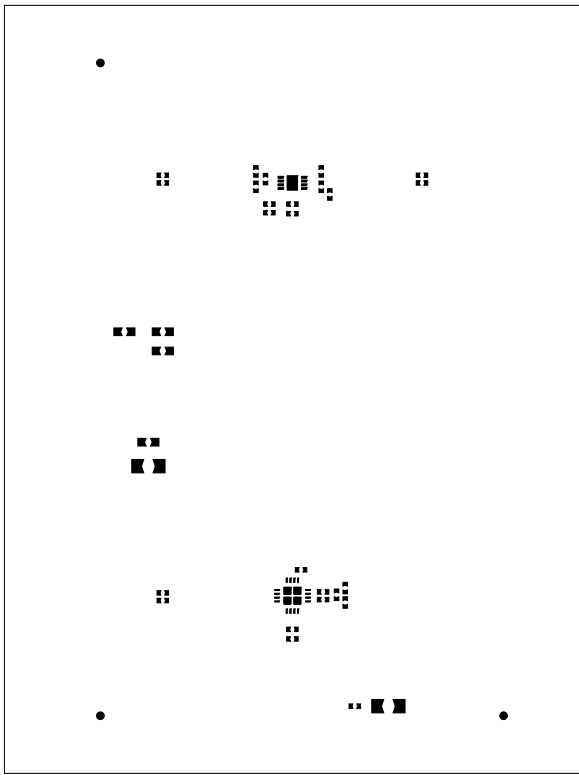

IMPORTANT NOTICE

Texas Instruments Incorporated and its subsidiaries (TI) reserve the right to make corrections, modifications, enhancements, improvements, and other changes to its products and services at any time and to discontinue any product or service without notice. Customers should obtain the latest relevant information before placing orders and should verify that such information is current and complete. All products are sold subject to TI's terms and conditions of sale supplied at the time of order acknowledgment.

TI warrants performance of its hardware products to the specifications applicable at the time of sale in accordance with TI's standard warranty. Testing and other quality control techniques are used to the extent TI deems necessary to support this warranty. Except where mandated by government requirements, testing of all parameters of each product is not necessarily performed.

TI assumes no liability for applications assistance or customer product design. Customers are responsible for their products and applications using TI components. To minimize the risks associated with customer products and applications, customers should provide adequate design and operating safeguards.

TI does not warrant or represent that any license, either express or implied, is granted under any TI patent right, copyright, mask work right, or other TI intellectual property right relating to any combination, machine, or process in which TI products or services are used. Information published by TI regarding third-party products or services does not constitute a license from TI to use such products or services or a warranty or endorsement thereof. Use of such information may require a license from a third party under the patents or other intellectual property of the third party, or a license from TI under the patents or other intellectual property of TI.

Reproduction of TI information in TI data books or data sheets is permissible only if reproduction is without alteration and is accompanied by all associated warranties, conditions, limitations, and notices. Reproduction of this information with alteration is an unfair and deceptive business practice. TI is not responsible or liable for such altered documentation. Information of third parties may be subject to additional restrictions.

Resale of TI products or services with statements different from or beyond the parameters stated by TI for that product or service voids all express and any implied warranties for the associated TI product or service and is an unfair and deceptive business practice. TI is not responsible or liable for any such statements.

TI products are not authorized for use in safety-critical applications (such as life support) where a failure of the TI product would reasonably be expected to cause severe personal injury or death, unless officers of the parties have executed an agreement specifically governing such use. Buyers represent that they have all necessary expertise in the safety and regulatory ramifications of their applications, and acknowledge and agree that they are solely responsible for all legal, regulatory and safety-related requirements concerning their products and any use of TI products in such safety-critical applications, notwithstanding any applications-related information or support that may be provided by TI. Further, Buyers must fully indemnify TI and its representatives against any damages arising out of the use of TI products in such safety-critical applications.

TI products are neither designed nor intended for use in military/aerospace applications or environments unless the TI products are specifically designated by TI as military-grade or "enhanced plastic." Only products designated by TI as military-grade meet military specifications. Buyers acknowledge and agree that any such use of TI products which TI has not designated as military-grade is solely at the Buyer's risk, and that they are solely responsible for compliance with all legal and regulatory requirements in connection with such use.

TI products are neither designed nor intended for use in automotive applications or environments unless the specific TI products are designated by TI as compliant with ISO/TS 16949 requirements. Buyers acknowledge and agree that, if they use any non-designated products in automotive applications, TI will not be responsible for any failure to meet such requirements.

Following are URLs where you can obtain information on other Texas Instruments products and application solutions:

Products

Audio	www.ti.com/audio
Amplifiers	amplifier.ti.com
Data Converters	dataconverter.ti.com
DLP® Products	www.dlp.com
DSP	dsp.ti.com
Clocks and Timers	www.ti.com/clocks
Interface	interface.ti.com
Logic	logic.ti.com
Power Mgmt	power.ti.com
Microcontrollers	microcontroller.ti.com
RFID	www.ti-rfid.com
OMAP Mobile Processors	www.ti.com/omap
Wireless Connectivity	www.ti.com/wirelessconnectivity

Applications

Automotive and Transportation	www.ti.com/automotive
Communications and Telecom	www.ti.com/communications
Computers and Peripherals	www.ti.com/computers
Consumer Electronics	www.ti.com/consumer-apps
Energy and Lighting	www.ti.com/energy
Industrial	www.ti.com/industrial
Medical	www.ti.com/medical
Security	www.ti.com/security
Space, Avionics and Defense	www.ti.com/space-avionics-defense
Video and Imaging	www.ti.com/video

TI E2E Community Home Page

e2e.ti.com

Mailing Address: Texas Instruments, Post Office Box 655303, Dallas, Texas 75265
Copyright © 2012, Texas Instruments Incorporated