

Keywords: audio subcarrier, notch filter, group-delay equalization, RF video modulator, NTSC,

APPLICATION NOTE 3745

Low-Cost Quad Op Amp Drives RF Modulator

Mar 13, 2006

Abstract: A video circuit combines an audio-subcarrier notch filter, group-delay equalization, and an amplitude-adjustment capability for driving an RF video modulator in NTSC applications.

The video circuit of **Figure 1** combines an audio-subcarrier notch filter and group-delay equalization as required by the ITU-470 standard. The circuit also includes amplitude-adjustment capability for driving an RF video modulator in NTSC applications. (PAL operation requires a minor adjustment of the filter and allpass values.)

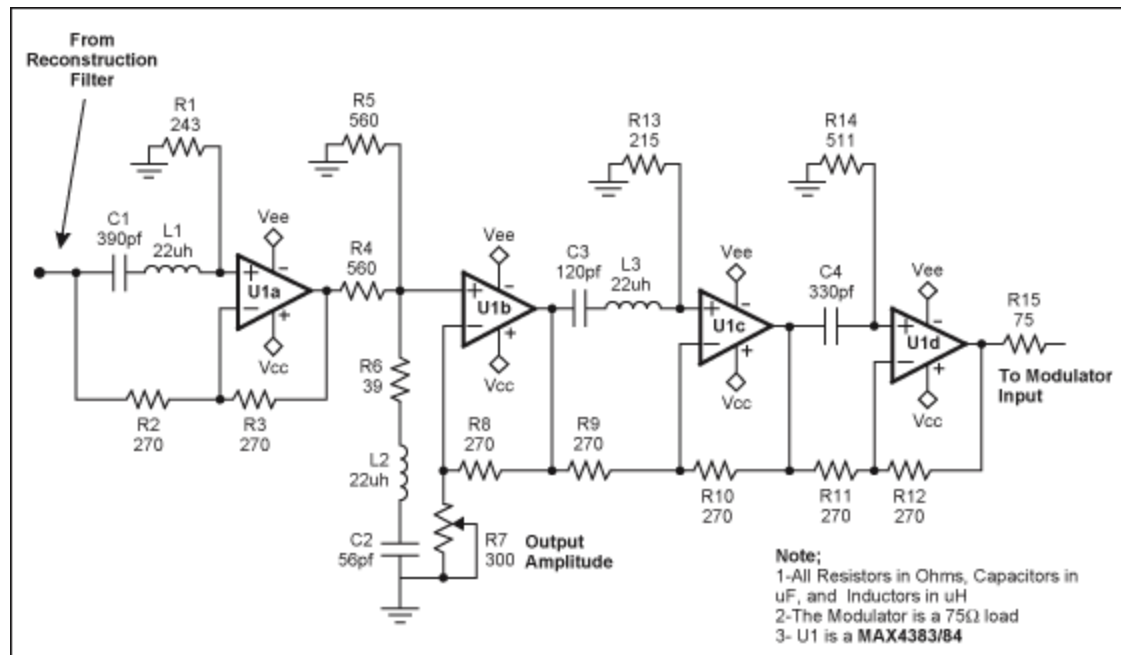

Figure 1. Bandstop filter and delay equalizer for NTSC applications.

For best performance, the input should be driven from a low-impedance source such as an op amp or active filter. Two second-order allpass stages (U1a, R1, C1, L1) and (U1c, R13, C3, L3) and a first-order allpass stage (U1d, C4, R14) form a fifth-order group-delay equalizer that compensates for group delay introduced by the notch filter (U1b, R6, C2, L2). See **Figure 2**. Potentiometer R7 adjusts the output amplitude as required by the modulator in use.

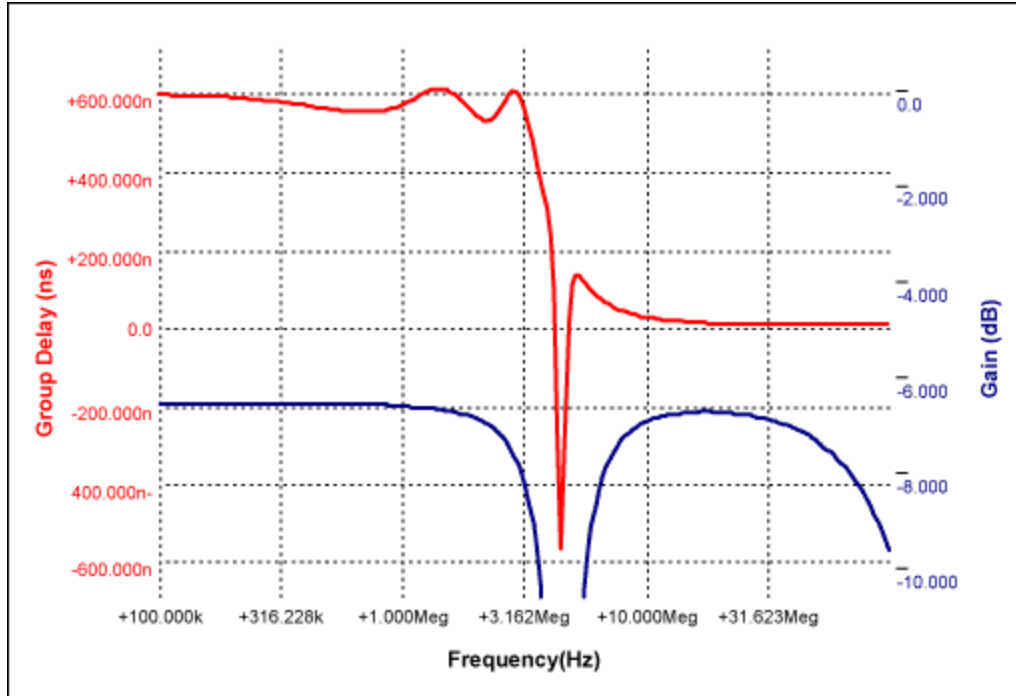

Figure 2. Gain and group-delay response for the notch filter and group-delay compensation of Figure 1.

The notch frequency is set by L2 and C2; the notch depth and bandwidth are set by R4, R5, and R6. The typical notch depth is greater than -16dB. Flatness above 2.5MHz is ± 0.5 dB.

A similar article appeared as a Design Brief in the July 21, 2005 issue of *Electronic Design*.

Related Parts

[MAX4383](#)

Ultra-Small, Low-Cost, 210MHz, Single-Supply Op Amps with Rail-to-Rail Outputs and Disable

[Free Samples](#)

More Information

For Technical Support: <http://www.maximintegrated.com/support>

For Samples: <http://www.maximintegrated.com/samples>

Other Questions and Comments: <http://www.maximintegrated.com/contact>

Application Note 3745: <http://www.maximintegrated.com/an3745>

APPLICATION NOTE 3745, AN3745, AN 3745, APP3745, Appnote3745, Appnote 3745

Copyright © by Maxim Integrated Products

Additional Legal Notices: <http://www.maximintegrated.com/legal>