

TMUX1219 5-V Bidirectional, 2:1 General Purpose Switch

1 Features

- Rail to rail operation
- Bidirectional signal path
- 1.8 V Logic compatible
- Fail-safe logic
- Low on-resistance: 3 Ω
- Wide supply range: 1.08 V to 5.5 V
- -40°C to +125°C Operating temperature
- Low supply current: 4 nA
- Transition time: 14 ns
- Break-before-make switching
- ESD protection HBM: 2000 V

2 Applications

- Analog and Digital Switching
- I2C and SPI bus Multiplexing
- Remote Radio Units
- Barcode scanner
- Motor drives
- Building automation
- Analog input module
- Power delivery
- Video surveillance
- Electronic point of sale
- Appliances
- Consumer audio

3 Description

The TMUX1219 is a general purpose complementary metal-oxide semiconductor (CMOS) single-pole double-throw (SPDT) switch. The TMUX1219 switches between two source inputs based on the state of the SEL pin. Wide operating supply of 1.08 V to 5.5 V allows for use in a broad array of applications from personal electronics to building automation. The device supports bidirectional analog and digital signals on the source (Sx) and drain (D) pins ranging from GND to V_{DD} . A low supply current of 4 nA enables use in portable applications.

All logic inputs have 1.8 V logic compatible thresholds, ensuring both TTL and CMOS logic compatibility when operating in the valid supply voltage range. Fail-Safe Logic circuitry allows voltages on the control pins to be applied before the supply pin, protecting the device from potential damage.

Device Information⁽¹⁾

PART NUMBER	PACKAGE	BODY SIZE (NOM)
TMUX1219	SC70 (6)	2.00 mm x 1.25 mm
	SOT-23 (6)	2.90 mm x 1.60 mm

(1) For all available packages, see the package option addendum at the end of the data sheet.

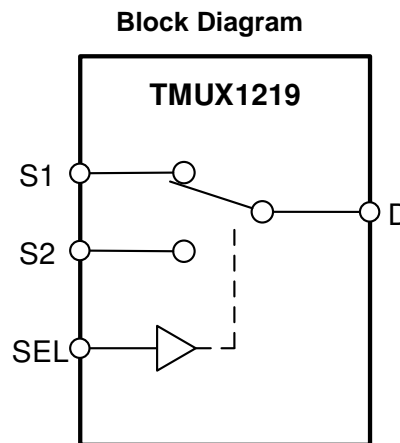
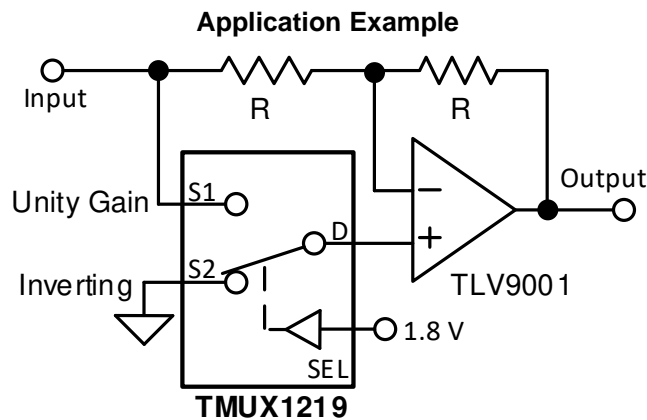

Table of Contents

1 Features	1	7.8 Crosstalk	17
2 Applications	1	7.9 Bandwidth	18
3 Description	1	8 Detailed Description	19
4 Revision History	2	8.1 Functional Block Diagram	19
5 Pin Configuration and Functions	3	8.2 Feature Description	19
6 Specifications	4	8.3 Device Functional Modes	19
6.1 Absolute Maximum Ratings	4	8.4 Truth Tables	19
6.2 ESD Ratings	4	9 Application and Implementation	20
6.3 Recommended Operating Conditions	4	9.1 Application Information	20
6.4 Thermal Information	4	9.2 Typical Application	20
6.5 Electrical Characteristics ($V_{DD} = 5\text{ V} \pm 10\%$)	5	10 Power Supply Recommendations	22
6.6 Electrical Characteristics ($V_{DD} = 3.3\text{ V} \pm 10\%$)	7	11 Layout	23
6.7 Electrical Characteristics ($V_{DD} = 1.8\text{ V} \pm 10\%$)	9	11.1 Layout Guidelines	23
6.8 Electrical Characteristics ($V_{DD} = 1.2\text{ V} \pm 10\%$)	11	11.2 Layout Example	23
6.9 Typical Characteristics	13	12 Device and Documentation Support	24
7 Parameter Measurement Information	14	12.1 Documentation Support	24
7.1 On-Resistance	14	12.2 Receiving Notification of Documentation Updates	24
7.2 Off-Leakage Current	14	12.3 Community Resources	24
7.3 On-Leakage Current	15	12.4 Trademarks	24
7.4 Transition Time	15	12.5 Electrostatic Discharge Caution	24
7.5 Break-Before-Make	16	12.6 Glossary	24
7.6 Charge Injection	16	13 Mechanical, Packaging, and Orderable Information	24
7.7 Off Isolation	17		

4 Revision History

NOTE: Page numbers for previous revisions may differ from page numbers in the current version.

Changes from Original (May 2019) to Revision A	Page
• Changed the DBV package status From: <i>Product Preview</i> To <i>Production Data</i>	1
• Added Thermal information for DBV package	4

5 Pin Configuration and Functions

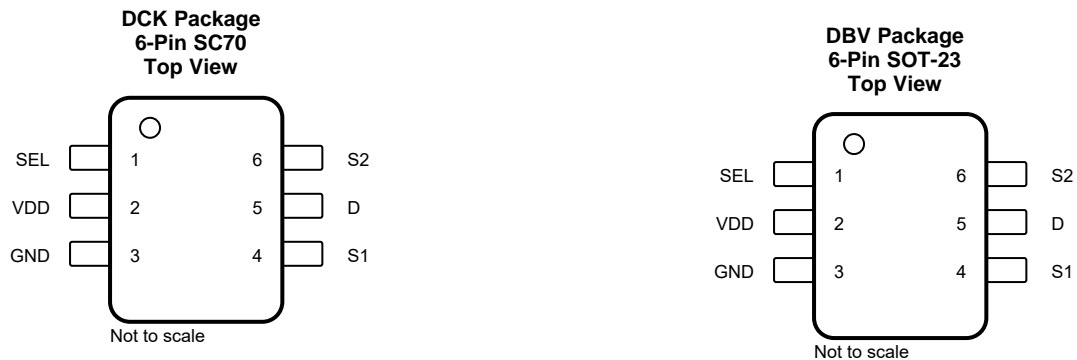

Pin Functions

PIN		TYPE ⁽¹⁾	DESCRIPTION
NAME	NO.		
SEL	1	I	Select pin: controls state of the switch according to Table 1 . (Logic Low = S1 to D, Logic High = S2 to D)
VDD	2	P	Positive power supply. This pin is the most positive power-supply potential. For reliable operation, connect a decoupling capacitor ranging from 0.1 μ F to 10 μ F between V_{DD} and GND.
GND	3	P	Ground (0 V) reference
S1	4	I/O	Source pin 1. Can be an input or output.
D	5	I/O	Drain pin. Can be an input or output.
S2	6	I/O	Source pin 2. Can be an input or output.

(1) I = input, O = output, I/O = input and output, P = power

6 Specifications

6.1 Absolute Maximum Ratings

Over operating free-air temperature range (unless otherwise noted)⁽¹⁾⁽²⁾.

		MIN	MAX	UNIT
V _{DD}	Supply voltage	-0.5	6	V
V _{SEL}	Logic control input pin voltage (SEL)	-0.5	6	V
I _{SEL}	Logic control input pin current (SEL)	-30	30	mA
V _S or V _D	Source or drain voltage (Sx, D)	-0.5	V _{DD} +0.5	V
I _S or I _D (CONT)	Source or drain continuous current (Sx, D)	-30	30	mA
T _{stg}	Storage temperature	-65	150	°C
T _J	Junction temperature		150	°C

- (1) Stresses beyond those listed under *Absolute Maximum Rating* may cause permanent damage to the device. These are stress ratings only, which do not imply functional operation of the device at these or any other conditions beyond those indicated under *Recommended Operating Condition*. Exposure to absolute-maximum-rated conditions for extended periods may affect device reliability.
- (2) The algebraic convention, whereby the most negative value is a minimum and the most positive value is a maximum.

6.2 ESD Ratings

			VALUE	UNIT
V _(ESD)	Electrostatic discharge	Human body model (HBM), per ANSI/ESDA/JEDEC JS-001, all pins ⁽¹⁾	±2000	V
		Charged device model (CDM), per JEDEC specification JESD22-C101 or ANSI/ESDA/JEDEC JS-002, all pins ⁽²⁾	±750	

- (1) JEDEC document JEP155 states that 500-V HBM allows safe manufacturing with a standard ESD control process.
- (2) JEDEC document JEP157 states that 250-V CDM allows safe manufacturing with a standard ESD control process.

6.3 Recommended Operating Conditions

Over operating free-air temperature range (unless otherwise noted).

		MIN	NOM	MAX	UNIT
V _{DD}	Supply voltage	1.08		5.5	V
V _S or V _D	Signal path input/output voltage (source or drain pin) (Sx, D)	0		V _{DD}	V
V _{SEL}	Logic control input pin voltage (SEL)	0		5.5	V
T _A	Ambient temperature	-40		125	°C

6.4 Thermal Information

THERMAL METRIC ⁽¹⁾		TMUX1219		UNIT
		DCK (SC70)	DBV (SOT-23)	
		6 PINS	6 PINS	
R _{θJA}	Junction-to-ambient thermal resistance	243.1	212.3	°C/W
R _{θJC(top)}	Junction-to-case (top) thermal resistance	206.0	156.7	°C/W
R _{θJB}	Junction-to-board thermal resistance	128.3	96.5	°C/W
Ψ _{JT}	Junction-to-top characterization parameter	107.8	80.7	°C/W
Ψ _{JB}	Junction-to-board characterization parameter	128.0	96.2	°C/W
R _{θJC(bot)}	Junction-to-case (bottom) thermal resistance	N/A	N/A	°C/W

- (1) For more information about traditional and new thermal metrics, see the [Semiconductor and IC Package Thermal Metrics](#) application report.

6.5 Electrical Characteristics ($V_{DD} = 5\text{ V} \pm 10\%$)

At $T_A = 25^\circ\text{C}$, $V_{DD} = 5\text{ V}$ (unless otherwise noted).

PARAMETER		TEST CONDITIONS	TA	MIN	TYP	MAX	UNIT
ANALOG SWITCH							
R_{ON}	On-resistance	$V_S = 0\text{ V to }V_{DD}$ $I_{SD} = 10\text{ mA}$ Refer to On-Resistance	25°C	3			Ω
			–40°C to +85°C			5	Ω
			–40°C to +125°C			6	Ω
ΔR_{ON}	On-resistance matching between channels	$V_S = 0\text{ V to }V_{DD}$ $I_{SD} = 10\text{ mA}$ Refer to On-Resistance	25°C	0.15			Ω
			–40°C to +85°C			0.4	Ω
			–40°C to +125°C			1	Ω
$R_{ON\text{ FLAT}}$	On-resistance flatness	$V_S = 0\text{ V to }V_{DD}$ $I_{SD} = 10\text{ mA}$ Refer to On-Resistance	25°C	1.5			Ω
			–40°C to +85°C			2	Ω
			–40°C to +125°C			3	Ω
$I_{S(OFF)}$	Source off leakage current ⁽¹⁾	$V_{DD} = 5\text{ V}$ Switch Off $V_D = 4.5\text{ V} / 1.5\text{ V}$ $V_S = 1.5\text{ V} / 4.5\text{ V}$ Refer to Off-Leakage Current	25°C	± 5			nA
			–40°C to +85°C	–25		25	nA
			–40°C to +125°C	–40		40	nA
$I_{D(ON)}$ $I_{S(ON)}$	Channel on leakage current	$V_{DD} = 5\text{ V}$ Switch On $V_D = V_S = 4.5\text{ V} / 1.5\text{ V}$ Refer to On-Leakage Current	25°C	± 15			nA
			–40°C to +85°C	–50		50	nA
			–40°C to +125°C	–80		80	nA
LOGIC INPUTS (SEL)							
V_{IH}	Input logic high		–40°C to +125°C	1.49		5.5	V
V_{IL}	Input logic low		–40°C to +125°C	0		0.87	V
I_{IH} I_{IL}	Input leakage current		25°C	± 0.005			μA
			–40°C to +125°C			± 0.05	μA
C_{IN}	Logic input capacitance		25°C	1			pF
C_{IN}	Logic input capacitance		–40°C to +125°C			2	pF
POWER SUPPLY							
I_{DD}	V_{DD} supply current	Logic inputs = 0 V or 5.5 V	25°C	0.003			μA
			–40°C to +125°C			1.5	μA

(1) When V_S is 4.5 V, V_D is 1.5 V or when V_S is 1.5 V, V_D is 4.5 V.

Electrical Characteristics ($V_{DD} = 5\text{ V} \pm 10\%$) (continued)

 At $T_A = 25^\circ\text{C}$, $V_{DD} = 5\text{ V}$ (unless otherwise noted).

PARAMETER		TEST CONDITIONS	TA	MIN	TYP	MAX	UNIT
DYNAMIC CHARACTERISTICS							
t_{TRAN}	Switching time between channels	$V_S = 3\text{ V}$ $R_L = 200\ \Omega$, $C_L = 15\text{ pF}$ Refer to Transition Time	25°C		12		ns
			–40°C to +85°C			18	ns
			–40°C to +125°C			19	ns
t_{OPEN} (BBM)	Break before make time	$V_S = 3\text{ V}$ $R_L = 200\ \Omega$, $C_L = 15\text{ pF}$ Refer to Break-Before-Make	25°C		8		ns
			–40°C to +85°C		1		ns
			–40°C to +125°C		1		ns
Q_C	Charge Injection	$V_D = 1\text{ V}$ $R_S = 0\ \Omega$, $C_L = 1\text{ nF}$ Refer to Charge Injection	25°C		–10		pC
O_{ISO}	Off Isolation	$R_L = 50\ \Omega$, $C_L = 5\text{ pF}$ $f = 1\text{ MHz}$ Refer to Off Isolation	25°C		–65		dB
			$R_L = 50\ \Omega$, $C_L = 5\text{ pF}$ $f = 10\text{ MHz}$ Refer to Off Isolation	25°C		–45	
X_{TALK}	Crosstalk	$R_L = 50\ \Omega$, $C_L = 5\text{ pF}$ $f = 1\text{ MHz}$ Refer to Crosstalk	25°C		–65		dB
			$R_L = 50\ \Omega$, $C_L = 5\text{ pF}$ $f = 10\text{ MHz}$ Refer to Crosstalk	25°C		–45	
BW	Bandwidth	$R_L = 50\ \Omega$, $C_L = 5\text{ pF}$ Refer to Bandwidth	25°C		250		MHz
C_{SOFF}	Source off capacitance	$f = 1\text{ MHz}$	25°C		7		pF
C_{SON} C_{DON}	On capacitance	$f = 1\text{ MHz}$	25°C		23		pF

6.6 Electrical Characteristics ($V_{DD} = 3.3\text{ V} \pm 10\%$)

At $T_A = 25^\circ\text{C}$, $V_{DD} = 3.3\text{ V}$ (unless otherwise noted).

PARAMETER		TEST CONDITIONS	TA	MIN	TYP	MAX	UNIT
ANALOG SWITCH							
R_{ON}	On-resistance	$V_S = 0\text{ V to }V_{DD}$ $I_{SD} = 10\text{ mA}$ Refer to On-Resistance	25°C	5			Ω
			-40°C to +85°C			10	Ω
			-40°C to +125°C			12	Ω
ΔR_{ON}	On-resistance matching between channels	$V_S = 0\text{ V to }V_{DD}$ $I_{SD} = 10\text{ mA}$ Refer to On-Resistance	25°C	0.15			Ω
			-40°C to +85°C			1	Ω
			-40°C to +125°C			1	Ω
$R_{ON\text{ FLAT}}$	On-resistance flatness	$V_S = 0\text{ V to }V_{DD}$ $I_{SD} = 10\text{ mA}$ Refer to On-Resistance	25°C	3.5			Ω
			-40°C to +85°C			4	Ω
			-40°C to +125°C			5	Ω
$I_{S(OFF)}$	Source off leakage current ⁽¹⁾	$V_{DD} = 3.3\text{ V}$ Switch Off $V_D = 3\text{ V} / 1\text{ V}$ $V_S = 1\text{ V} / 3\text{ V}$ Refer to Off-Leakage Current	25°C	± 5			nA
			-40°C to +85°C	-25		25	nA
			-40°C to +125°C	-40		40	nA
$I_{D(ON)}$ $I_{S(ON)}$	Channel on leakage current	$V_{DD} = 3.3\text{ V}$ Switch On $V_D = V_S = 3\text{ V} / 1\text{ V}$ Refer to On-Leakage Current	25°C	± 15			nA
			-40°C to +85°C	-50		50	nA
			-40°C to +125°C	-80		80	nA
LOGIC INPUTS (SEL)							
V_{IH}	Input logic high		-40°C to +125°C	1.35		5.5	V
V_{IL}	Input logic low		-40°C to +125°C	0		0.8	V
I_{IH} I_{IL}	Input leakage current		25°C	± 0.005			μA
			-40°C to 125°C			± 0.05	μA
C_{IN}	Logic input capacitance		25°C	1			pF
C_{IN}	Logic input capacitance		-40°C to +125°C			2	pF
POWER SUPPLY							
I_{DD}	V_{DD} supply current	Logic inputs = 0 V or 5.5 V	25°C	0.003			μA
			-40°C to +125°C			0.8	μA

(1) When V_S is 3 V, V_D is 1 V or when V_S is 1 V, V_D is 3 V.

Electrical Characteristics ($V_{DD} = 3.3\text{ V} \pm 10\%$) (continued)

 At $T_A = 25^\circ\text{C}$, $V_{DD} = 3.3\text{ V}$ (unless otherwise noted).

PARAMETER		TEST CONDITIONS	TA	MIN	TYP	MAX	UNIT
DYNAMIC CHARACTERISTICS							
t_{TRAN}	Switching time between channels	$V_S = 2\text{ V}$ $R_L = 200\ \Omega$, $C_L = 15\text{ pF}$ Refer to Transition Time	25°C	14			ns
			–40°C to +85°C			20	ns
			–40°C to +125°C			21	ns
t_{OPEN} (BBM)	Break before make time	$V_S = 2\text{ V}$ $R_L = 200\ \Omega$, $C_L = 15\text{ pF}$ Refer to Break-Before-Make	25°C	9			ns
			–40°C to +85°C	1			ns
			–40°C to +125°C	1			ns
Q_C	Charge Injection	$V_D = 1\text{ V}$ $R_S = 0\ \Omega$, $C_L = 1\text{ nF}$ Refer to Charge Injection	25°C		–6		pC
O_{ISO}	Off Isolation	$R_L = 50\ \Omega$, $C_L = 5\text{ pF}$ $f = 1\text{ MHz}$ Refer to Off Isolation	25°C		–65		dB
			$R_L = 50\ \Omega$, $C_L = 5\text{ pF}$ $f = 10\text{ MHz}$ Refer to Off Isolation	25°C		–45	
X_{TALK}	Crosstalk	$R_L = 50\ \Omega$, $C_L = 5\text{ pF}$ $f = 1\text{ MHz}$ Refer to Crosstalk	25°C		–65		dB
			$R_L = 50\ \Omega$, $C_L = 5\text{ pF}$ $f = 10\text{ MHz}$ Refer to Crosstalk	25°C		–45	
BW	Bandwidth	$R_L = 50\ \Omega$, $C_L = 5\text{ pF}$ Refer to Bandwidth	25°C		250		MHz
C_{SOFF}	Source off capacitance	$f = 1\text{ MHz}$	25°C		7		pF
C_{SON} C_{DON}	On capacitance	$f = 1\text{ MHz}$	25°C		23		pF

6.7 Electrical Characteristics ($V_{DD} = 1.8\text{ V} \pm 10\%$)

At $T_A = 25^\circ\text{C}$, $V_{DD} = 1.8\text{ V}$ (unless otherwise noted).

PARAMETER		TEST CONDITIONS	TA	MIN	TYP	MAX	UNIT
ANALOG SWITCH							
R_{ON}	On-resistance	$V_S = 0\text{ V to }V_{DD}$ $I_{SD} = 10\text{ mA}$ Refer to On-Resistance	25°C	40			Ω
			-40°C to +85°C			80	Ω
			-40°C to +125°C			80	Ω
ΔR_{ON}	On-resistance matching between channels	$V_S = 0\text{ V to }V_{DD}$ $I_{SD} = 10\text{ mA}$ Refer to On-Resistance	25°C	0.4			Ω
			-40°C to +85°C			1.5	Ω
			-40°C to +125°C			1.5	Ω
$I_{S(OFF)}$	Source off leakage current ⁽¹⁾	$V_{DD} = 1.98\text{ V}$ Switch Off $V_D = 1.62\text{ V} / 1\text{ V}$ $V_S = 1\text{ V} / 1.62\text{ V}$ Refer to Off-Leakage Current	25°C	± 5			nA
			-40°C to +85°C	-25		25	nA
			-40°C to +125°C	-40		40	nA
$I_{D(ON)}$ $I_{S(ON)}$	Channel on leakage current	$V_{DD} = 1.98\text{ V}$ Switch On $V_D = V_S = 1.62\text{ V} / 1\text{ V}$ Refer to On-Leakage Current	25°C	± 15			nA
			-40°C to +85°C	-50		50	nA
			-40°C to +125°C	-80		80	nA
LOGIC INPUTS (SEL)							
V_{IH}	Input logic high		-40°C to +125°C	1.07		5.5	V
V_{IL}	Input logic low		-40°C to +125°C	0		0.68	V
I_{IH} I_{IL}	Input leakage current		25°C	± 0.005			μA
			-40°C to +125°C			± 0.05	μA
C_{IN}	Logic input capacitance		25°C	1			pF
C_{IN}	Logic input capacitance		-40°C to +125°C			2	pF
POWER SUPPLY							
I_{DD}	V_{DD} supply current	Logic inputs = 0 V or 5.5 V	25°C	0.001			μA
			-40°C to +125°C			0.6	μA

(1) When V_S is 1.62 V, V_D is 1 V or when V_S is 1 V, V_D is 1.62 V.

Electrical Characteristics ($V_{DD} = 1.8\text{ V} \pm 10\%$) (continued)

 At $T_A = 25^\circ\text{C}$, $V_{DD} = 1.8\text{ V}$ (unless otherwise noted).

PARAMETER		TEST CONDITIONS	TA	MIN	TYP	MAX	UNIT
DYNAMIC CHARACTERISTICS							
t_{TRAN}	Transition time between channels	$V_S = 1\text{ V}$ $R_L = 200\ \Omega$, $C_L = 15\text{ pF}$ Refer to Transition Time	25°C		28		ns
			–40°C to +85°C			44	ns
			–40°C to +125°C			44	ns
t_{OPEN} (BBM)	Break before make time	$V_S = 1\text{ V}$ $R_L = 200\ \Omega$, $C_L = 15\text{ pF}$ Refer to Break-Before-Make	25°C		16		ns
			–40°C to +85°C		1		ns
			–40°C to +125°C		1		ns
Q_C	Charge Injection	$V_D = 1\text{ V}$ $R_S = 0\ \Omega$, $C_L = 1\text{ nF}$ Refer to Charge Injection	25°C		–3		pC
O_{ISO}	Off Isolation	$R_L = 50\ \Omega$, $C_L = 5\text{ pF}$ $f = 1\text{ MHz}$ Refer to Off Isolation	25°C		–65		dB
			$R_L = 50\ \Omega$, $C_L = 5\text{ pF}$ $f = 10\text{ MHz}$ Refer to Off Isolation	25°C		–45	
X_{TALK}	Crosstalk	$R_L = 50\ \Omega$, $C_L = 5\text{ pF}$ $f = 1\text{ MHz}$ Refer to Crosstalk	25°C		–65		dB
			$R_L = 50\ \Omega$, $C_L = 5\text{ pF}$ $f = 10\text{ MHz}$ Refer to Crosstalk	25°C		–45	
BW	Bandwidth	$R_L = 50\ \Omega$, $C_L = 5\text{ pF}$	25°C		250		MHz
C_{SOFF}	Source off capacitance	$f = 1\text{ MHz}$	25°C		7		pF
C_{SON} C_{DON}	On capacitance	$f = 1\text{ MHz}$	25°C		23		pF

6.8 Electrical Characteristics ($V_{DD} = 1.2\text{ V} \pm 10\%$)

At $T_A = 25^\circ\text{C}$, $V_{DD} = 1.2\text{ V}$ (unless otherwise noted).

PARAMETER		TEST CONDITIONS	TA	MIN	TYP	MAX	UNIT
ANALOG SWITCH							
R_{ON}	On-resistance	$V_S = 0\text{ V to }V_{DD}$ $I_{SD} = 10\text{ mA}$ Refer to On-Resistance	25°C	70			Ω
			-40°C to +85°C			105	Ω
			-40°C to +125°C			105	Ω
ΔR_{ON}	On-resistance matching between channels	$V_S = 0\text{ V to }V_{DD}$ $I_{SD} = 10\text{ mA}$ Refer to On-Resistance	25°C	0.4			Ω
			-40°C to +85°C			1.5	Ω
			-40°C to +125°C			1.5	Ω
$I_{S(OFF)}$	Source off leakage current ⁽¹⁾	$V_{DD} = 1.32\text{ V}$ Switch Off $V_D = 1\text{ V} / 0.8\text{ V}$ $V_S = 0.8\text{ V} / 1\text{ V}$ Refer to Off-Leakage Current	25°C	± 5			nA
			-40°C to +85°C	-25		25	nA
			-40°C to +125°C	-40		40	nA
$I_{D(ON)}$ $I_{S(ON)}$	Channel on leakage current	$V_{DD} = 1.32\text{ V}$ Switch On $V_D = V_S = 1\text{ V} / 0.8\text{ V}$ Refer to On-Leakage Current	25°C	± 15			nA
			-40°C to +85°C	-50		50	nA
			-40°C to +125°C	-80		80	nA
LOGIC INPUTS (SEL)							
V_{IH}	Input logic high		-40°C to +125°C	0.96		5.5	V
V_{IL}	Input logic low		-40°C to +125°C	0		0.36	V
I_{IH} I_{IL}	Input leakage current		25°C	± 0.005			μA
			-40°C to +125°C			± 0.05	μA
C_{IN}	Logic input capacitance		25°C	1			pF
C_{IN}	Logic input capacitance		-40°C to +125°C			2	pF
POWER SUPPLY							
I_{DD}	V_{DD} supply current	Logic inputs = 0 V or 5.5 V	25°C	0.003			μA
			-40°C to +125°C			0.5	μA

(1) When V_S is 1 V, V_D is 0.8 V or when V_S is 0.8 V, V_D is 1 V.

Electrical Characteristics ($V_{DD} = 1.2\text{ V} \pm 10\%$) (continued)

 At $T_A = 25^\circ\text{C}$, $V_{DD} = 1.2\text{ V}$ (unless otherwise noted).

PARAMETER		TEST CONDITIONS	TA	MIN	TYP	MAX	UNIT
DYNAMIC CHARACTERISTICS							
t_{TRAN}	Transition time between channels	$V_S = 1\text{ V}$ $R_L = 200\ \Omega$, $C_L = 15\text{ pF}$ Refer to Transition Time	25°C		55		ns
			-40°C to +85°C			190	ns
			-40°C to +125°C			190	ns
t_{OPEN} (BBM)	Break before make time	$V_S = 1\text{ V}$ $R_L = 200\ \Omega$, $C_L = 15\text{ pF}$ Refer to Break-Before-Make	25°C		28		ns
			-40°C to +85°C		1		ns
			-40°C to +125°C		1		ns
Q_C	Charge Injection	$V_D = 1\text{ V}$ $R_S = 0\ \Omega$, $C_L = 1\text{ nF}$ Refer to Charge Injection	25°C		-2		pC
O_{ISO}	Off Isolation	$R_L = 50\ \Omega$, $C_L = 5\text{ pF}$ $f = 1\text{ MHz}$ Refer to Off Isolation	25°C		-65		dB
			$R_L = 50\ \Omega$, $C_L = 5\text{ pF}$ $f = 10\text{ MHz}$ Refer to Off Isolation	25°C		-45	
X_{TALK}	Crosstalk	$R_L = 50\ \Omega$, $C_L = 5\text{ pF}$ $f = 1\text{ MHz}$ Refer to Crosstalk	25°C		-65		dB
			$R_L = 50\ \Omega$, $C_L = 5\text{ pF}$ $f = 10\text{ MHz}$ Refer to Crosstalk	25°C		-45	
BW	Bandwidth	$R_L = 50\ \Omega$, $C_L = 5\text{ pF}$	25°C		250		MHz
C_{SOFF}	Source off capacitance	$f = 1\text{ MHz}$	25°C		7		pF
C_{SON} C_{DON}	On capacitance	$f = 1\text{ MHz}$	25°C		23		pF

6.9 Typical Characteristics

at $T_A = 25^\circ\text{C}$, $V_{DD} = 5\text{ V}$ (unless otherwise noted)

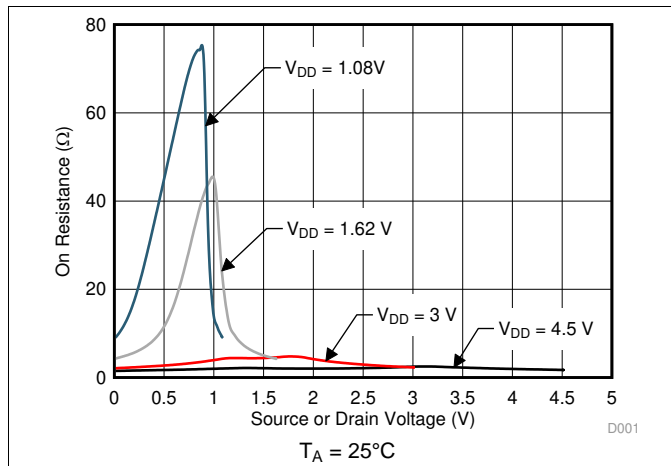

Figure 1. On-Resistance vs Source or Drain Voltage

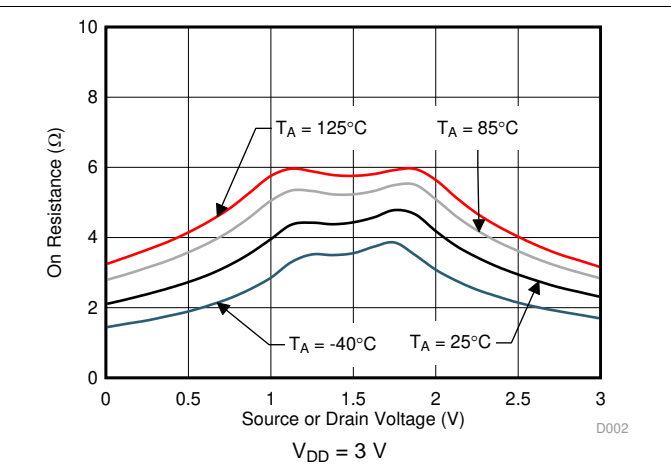

Figure 2. On-Resistance vs Source or Drain Voltage

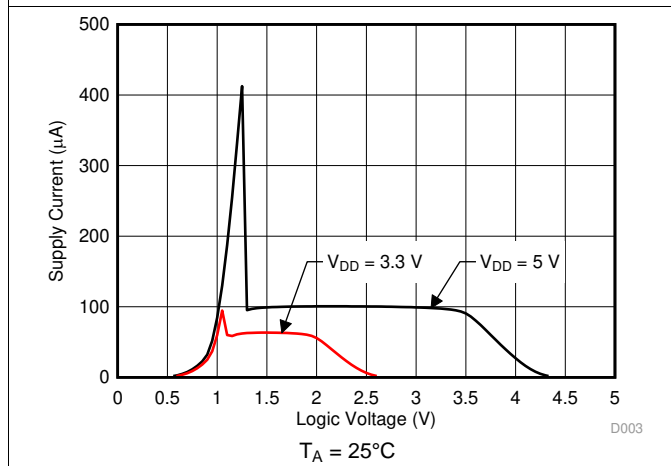

Figure 3. Supply Current vs Logic Voltage

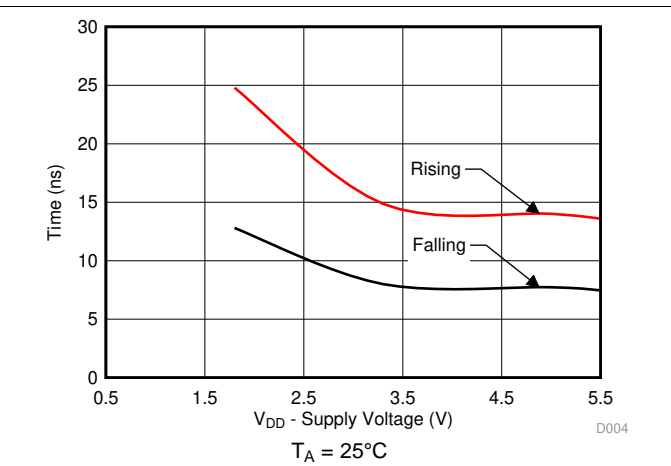

Figure 4. $T_{\text{transition}}$ vs Supply Voltage

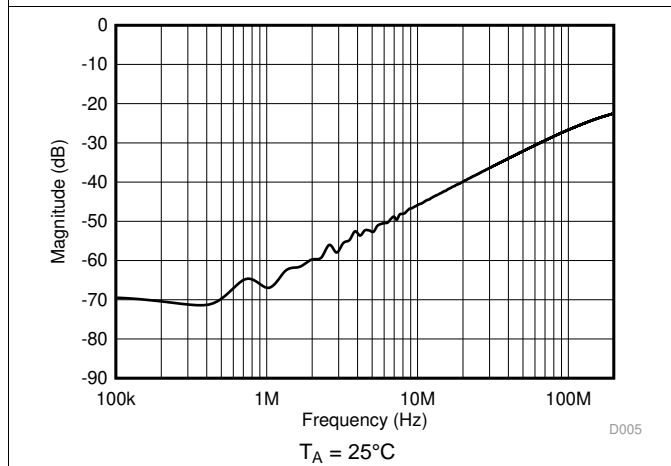

Figure 5. Crosstalk and Off-Isolation vs Frequency

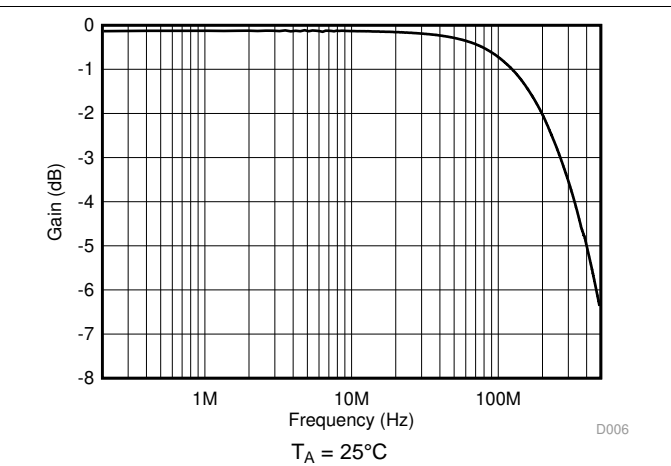

Figure 6. Frequency Response

7 Parameter Measurement Information

7.1 On-Resistance

The on-resistance of a device is the ohmic resistance between the source (Sx) and drain (D) pins of the device. The on-resistance varies with input voltage and supply voltage. The symbol R_{ON} is used to denote on-resistance. The measurement setup used to measure R_{ON} is shown in Figure 7. Voltage (V) and current (I_{SD}) are measured using this setup, and R_{ON} is computed with $R_{ON} = V / I_{SD}$:

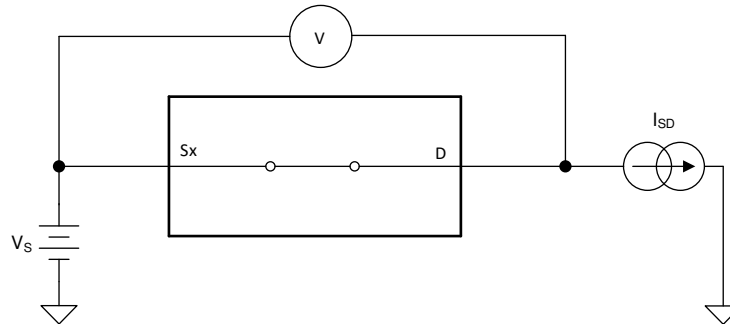

Figure 7. On-Resistance Measurement Setup

7.2 Off-Leakage Current

Source leakage current is defined as the leakage current flowing into or out of the source pin when the switch is off. This current is denoted by the symbol $I_{S(OFF)}$.

The setup used to measure off-leakage current is shown in Figure 8.

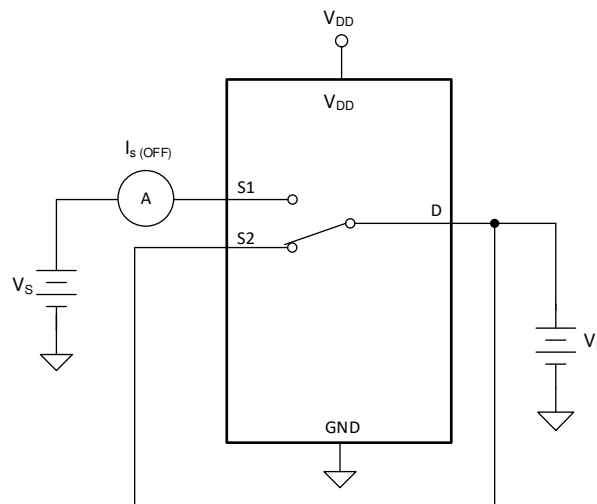

Figure 8. Off-Leakage Measurement Setup

7.3 On-Leakage Current

Source on-leakage current is defined as the leakage current flowing into or out of the source pin when the switch is on. This current is denoted by the symbol $I_{S(ON)}$.

Drain on-leakage current is defined as the leakage current flowing into or out of the drain pin when the switch is on. This current is denoted by the symbol $I_{D(ON)}$.

Either the source pin or drain pin is left floating during the measurement. Figure 9 shows the circuit used for measuring the on-leakage current, denoted by $I_{S(ON)}$ or $I_{D(ON)}$.

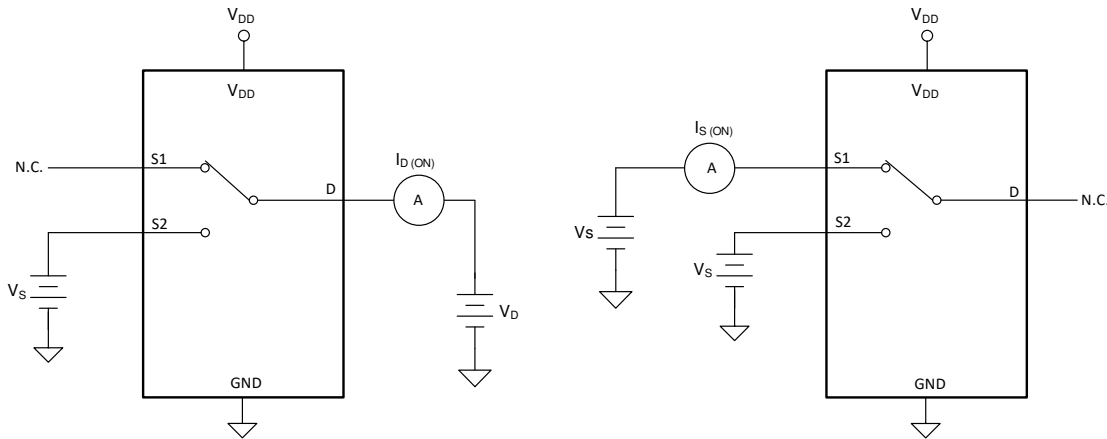

Figure 9. On-Leakage Measurement Setup

7.4 Transition Time

Transition time is defined as the time taken by the output of the device to rise or fall 10% after the logic control signal has risen or fallen past the logic threshold. The 10% transition measurement is utilized to provide the timing of the device. System level timing can then account for the time constant added from the load resistance and load capacitance. Figure 10 shows the setup used to measure transition time, denoted by the symbol $t_{TRANSITION}$.

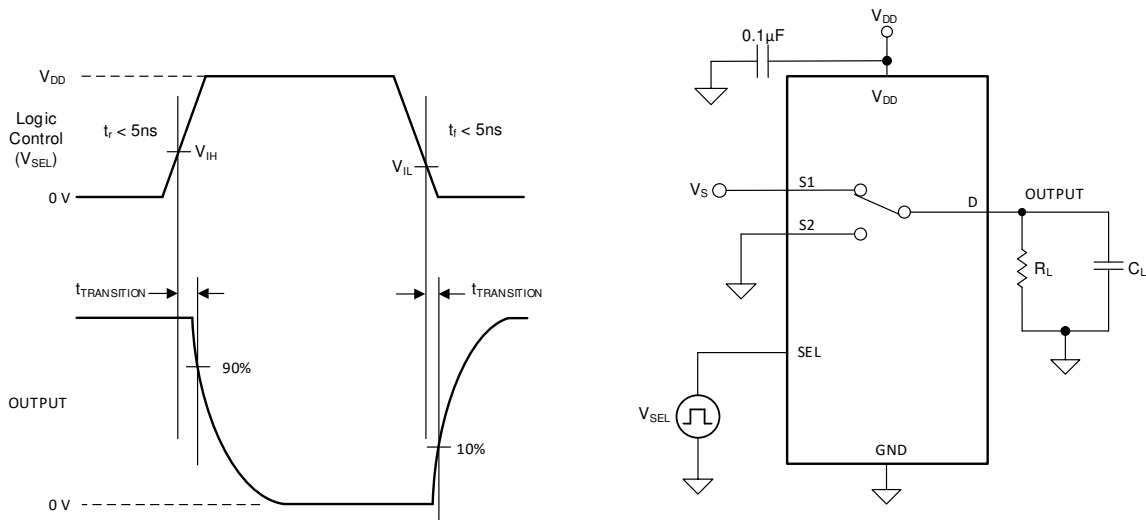

Figure 10. Transition-Time Measurement Setup

7.5 Break-Before-Make

Break-before-make delay is a safety feature that prevents two inputs from connecting when the device is switching. The output first breaks from the on-state switch before making the connection with the next on-state switch. The time delay between the *break* and the *make* is known as break-before-make delay. Figure 11 shows the setup used to measure break-before-make delay, denoted by the symbol $t_{OPEN(BBM)}$.

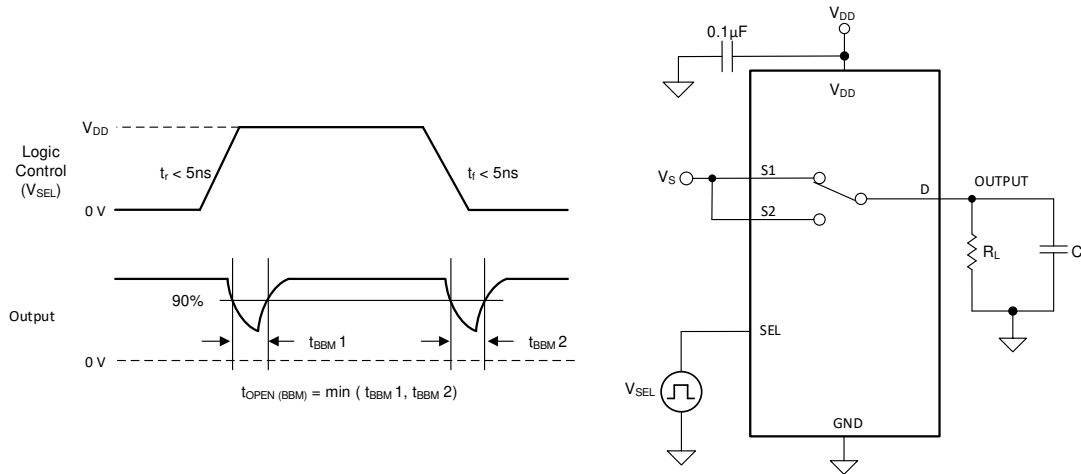

Figure 11. Break-Before-Make Delay Measurement Setup

7.6 Charge Injection

The TMUX1219 has a transmission-gate topology. Any mismatch in capacitance between the NMOS and PMOS transistors results in a charge injected into the drain or source during the falling or rising edge of the gate signal. The amount of charge injected into the source or drain of the device is known as charge injection, and is denoted by the symbol Q_C . Figure 12 shows the setup used to measure charge injection from Drain (D) to Source (Sx).

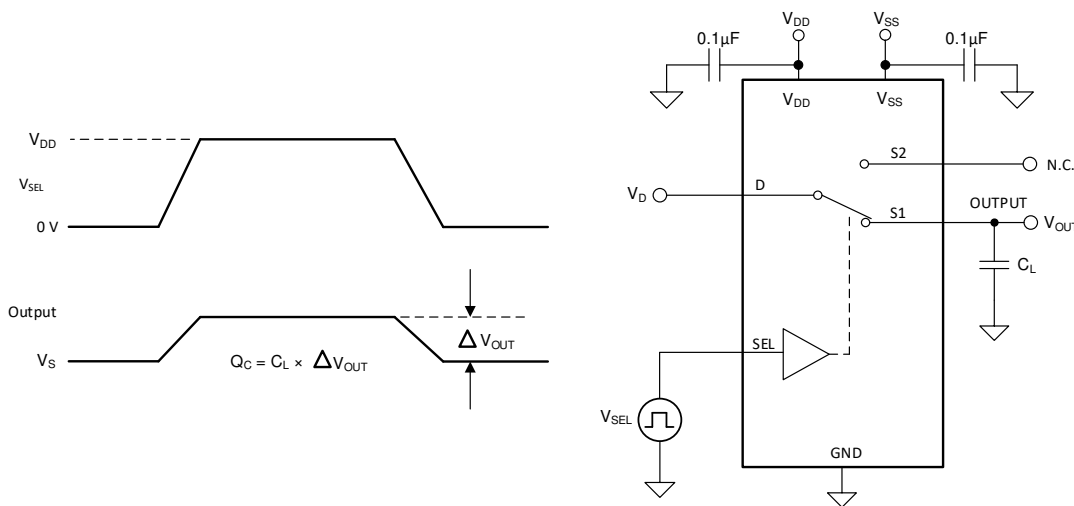

Figure 12. Charge-Injection Measurement Setup

7.7 Off Isolation

Off isolation is defined as the ratio of the signal at the drain pin (D) of the device when a signal is applied to the source pin (Sx) of an off-channel. Figure 13 shows the setup used to measure, and the equation used to calculate off isolation.

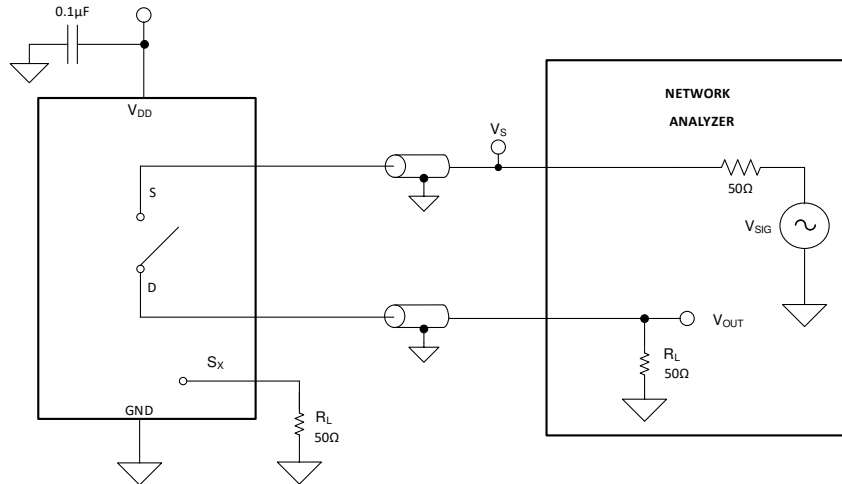

Figure 13. Off Isolation Measurement Setup

$$\text{Off Isolation} = 20 \cdot \text{Log} \left(\frac{V_{\text{OUT}}}{V_{\text{S}}} \right) \quad (1)$$

7.8 Crosstalk

Crosstalk is defined as the ratio of the signal at the drain pin (D) of a different channel, when a signal is applied at the source pin (Sx) of an on-channel. Figure 14 shows the setup used to measure, and the equation used to calculate crosstalk.

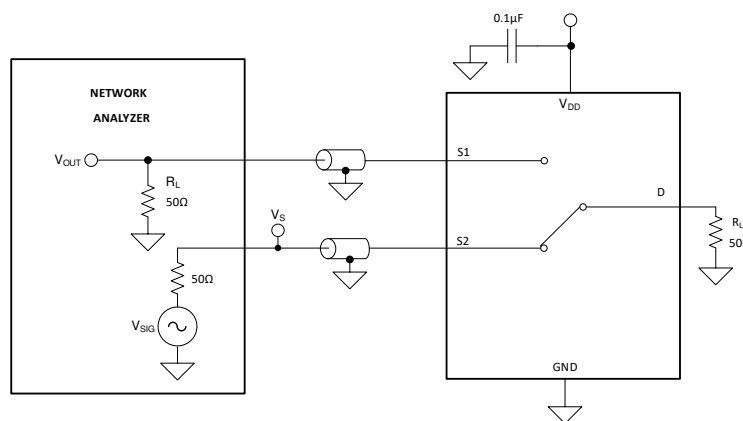

Figure 14. Crosstalk Measurement Setup

$$\text{Channel-to-Channel Crosstalk} = 20 \cdot \text{Log} \left(\frac{V_{\text{OUT}}}{V_{\text{S}}} \right) \quad (2)$$

7.9 Bandwidth

Bandwidth is defined as the range of frequencies that are attenuated by less than 3 dB when the input is applied to the source pin (Sx) of an on-channel, and the output is measured at the drain pin (D) of the device. [Figure 15](#) shows the setup used to measure bandwidth.

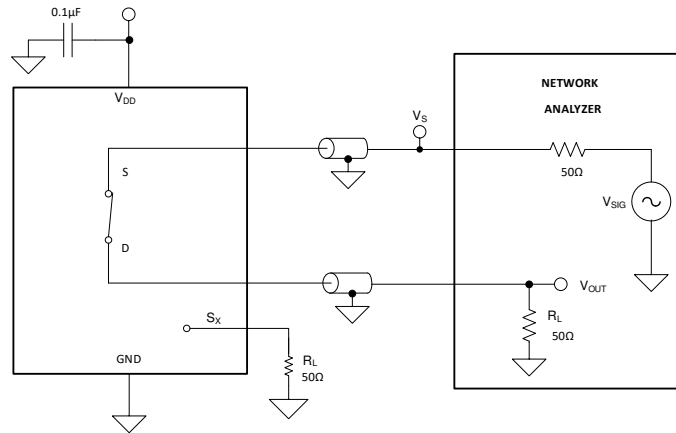

Figure 15. Bandwidth Measurement Setup

8 Detailed Description

8.1 Functional Block Diagram

The TMUX1219 is an 2:1 (SPDT), 1-channel switch where the input is controlled with a single select (SEL) control pin.

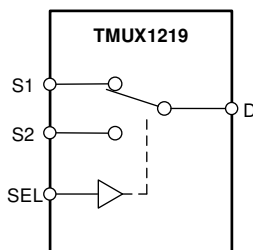

Figure 16. TMUX1219 Functional Block Diagram

8.2 Feature Description

8.2.1 Bidirectional Operation

The TMUX1219 conducts equally well from source (Sx) to drain (D) or from drain (D) to source (Sx). The device has very similar characteristics in both directions and supports both analog and digital signals.

8.2.2 Rail to Rail Operation

The valid signal path input/output voltage for TMUX1219 ranges from GND to V_{DD} .

8.2.3 1.8 V Logic Compatible Inputs

The TMUX1219 has 1.8-V logic compatible control for the logic control input (SEL). The logic input threshold scales with supply but still provides 1.8-V logic control when operating at 5.5 V supply voltage. 1.8-V logic level inputs allow the TMUX1219 to interface with processors that have lower logic I/O rails and eliminates the need for an external translator, which saves both space and BOM cost. For more information on 1.8 V logic implementations refer to [Simplifying Design with 1.8 V logic Muxes and Switches](#)

8.2.4 Fail-Safe Logic

The TMUX1219 supports Fail-Safe Logic on the control input pin (SEL) allowing for operation up to 5.5 V, regardless of the state of the supply pin. This feature allows voltages on the control pin to be applied before the supply pin, protecting the device from potential damage. Fail-Safe Logic minimizes system complexity by removing the need for power supply sequencing on the logic control pins. For example, the Fail-Safe Logic feature allows the select pin of the TMUX1219 to be ramped to 5.5 V while $V_{DD} = 0$ V. Additionally, the feature enables operation of the TMUX1219 with $V_{DD} = 1.2$ V while allowing the select pin to interface with a logic level of another device up to 5.5 V.

8.3 Device Functional Modes

The select (SEL) pin of the TMUX1219 controls which source channel is connected to the drain of the device. When a signal path is not selected, that source pin is in high impedance mode (HI-Z). The control pin can be as high as 5.5 V.

8.4 Truth Tables

Table 1. TMUX1219 Truth Table

CONTROL LOGIC (SEL)	Selected Source (Sx) Connected To Drain (D) Pin
0	S1
1	S2

9 Application and Implementation

NOTE

Information in the following applications sections is not part of the TI component specification, and TI does not warrant its accuracy or completeness. TI's customers are responsible for determining suitability of components for their purposes. Customers should validate and test their design implementation to confirm system functionality.

9.1 Application Information

The TMUX12xx family offers good system performance across a wide operating supply (1.08V to 5.5V). These devices include 1.8V logic compatible control input pins that enable operation in systems with 1.8V I/O rails. Additionally, the control input pin supports Fail-Safe Logic which allows for operation up to 5.5V, regardless of the state of the supply pin. This protection stops the logic pins from back-powering the supply rail. These features of the TMUX12xx, a family of general purpose multiplexers and switches, reduce system complexity, board size, and overall system cost.

9.2 Typical Application

9.2.1 Switchable Operational Amplifier Gain Setting

One example application of the TMUX1219 is to change an Op Amp from unity gain setting to an inverting amplifier configuration. Utilizing a switch allows a system to have a configurable gain and allows the same architecture to be utilized across the board for various inputs to the system. Figure 17 shows the TMUX1219 configured for gain setting application.

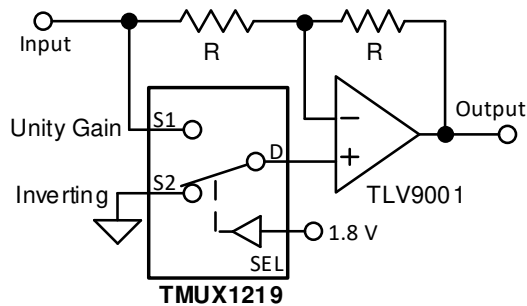

Figure 17. Switchable Op Amp Gain Setting

9.2.1.1 Design Requirements

This design example uses the parameters listed in Table 2.

Table 2. Design Parameters

PARAMETERS	VALUES
Input Signal	0 V to 2.75 V
Mux Supply (V_{DD})	2.75 V
Op Amp Supply (V_+ / V_-)	± 2.75 V
Mux I/O signal range	0 V to V_{DD} (Rail to Rail)
Control logic thresholds	1.8 V compatible (up to 5.5V)

9.2.1.2 Detailed Design Procedure

The application shown in Figure 17 demonstrates how to use a single control input and toggle between gain settings of -1 and +1. If switching between inverting and unity gain is not required, the TMUX1219 can be utilized in the feedback path to select different feedback resistors and provide scalable gain settings for configurable signal conditioning.

The TMUX1219 can be operated without any external components except for the supply decoupling capacitors. The select pin is recommended to have a weak pull-down or pull-up resistor to ensure the input is in a known state. All inputs to the switch must fall within the recommend operating conditions of the TMUX1219 including signal range and continuous current. For this design with a supply of 2.75 V the signal range can be 0 V to 2.75 V and the max continuous current can be 30 mA.

9.2.1.3 Application Curve

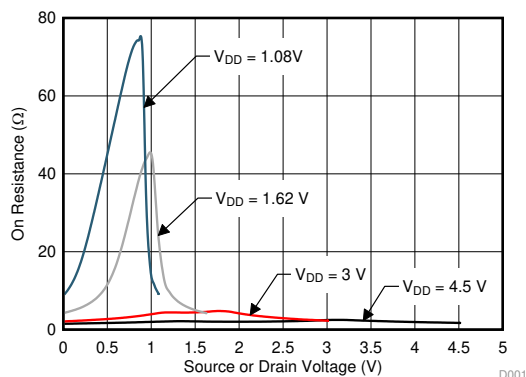

T_A = 25°C

Figure 18. On-Resistance vs Source or Drain Voltage

9.2.2 Input Control for Power Amplifier

Another application of the TMUX1219 is for input control of a power amplifier. Utilizing a switch allows a system to control when the DAC is connected to the power amplifier, and can stop biasing the power amplifier by switching the gate to GND. Figure 19 shows the TMUX1219 configured for control of the power amplifier.

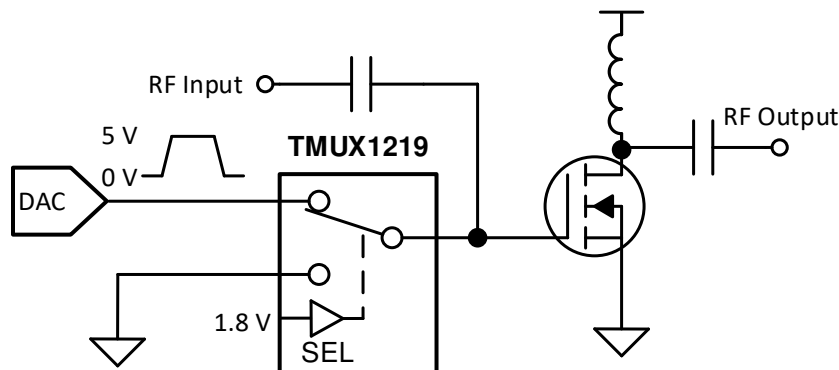

Figure 19. Input Control of Power Amplifier

9.2.2.1 Design Requirements

This design example uses the parameters listed in [Table 2](#).

Table 3. Design Parameters

PARAMETERS	VALUES
Supply (V_{DD})	5 V
Mux I/O signal range	0 V to V_{DD} (Rail to Rail)
Control logic thresholds	1.8 V compatible (up to 5.5V)

9.2.2.2 Detailed Design Procedure

The application shown in [Figure 19](#) demonstrates how to toggle between the DAC output and GND for control of a power amplifier using a single control input. The DAC output is utilized to bias the gate of the power amplifier and can be disconnected from the circuit using the select pin of the switch. The TMUX1219 can support 1.8-V logic signals on the control input, allowing the device to interface with low logic controls of an FPGA or MCU. The TMUX1219 can be operated without any external components except for the supply decoupling capacitors. The select pin is recommended to have a weak pull-down or pull-up resistor to ensure the input is in a known state. All inputs to the switch must fall within the recommend operating conditions of the TMUX1219 including signal range and continuous current. For this design with a supply of 5 V the signal range can be 0 V to 5 V and the max continuous current can be 30 mA.

9.2.2.3 Application Curve

A key parameter for this application is the transition time of the device. Faster transition time allows the system to toggle between input sources at a faster rate and allows the output to settle to the final value. The TMUX1219 has a transition time that varies with supply voltage and is shown in [Figure 20](#)

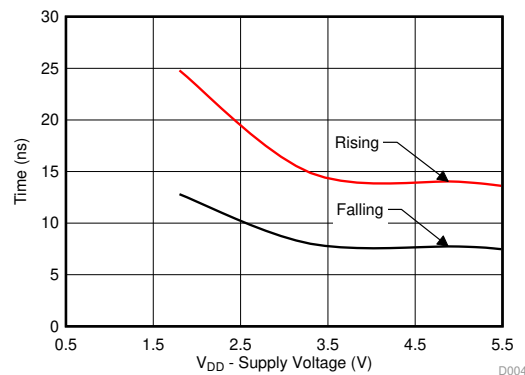

$$T_A = 25^\circ\text{C}$$

Figure 20. $T_{\text{transition}}$ vs Supply Voltage

10 Power Supply Recommendations

The TMUX1219 operates across a wide supply range of 1.08 V to 5.5 V. Do not exceed the absolute maximum ratings because stresses beyond the listed ratings can cause permanent damage to the devices.

Power-supply bypassing improves noise margin and prevents switching noise propagation from the V_{DD} supply to other components. Good power-supply decoupling is important to achieve optimum performance. For improved supply noise immunity, use a supply decoupling capacitor ranging from 0.1 μF to 10 μF from V_{DD} to ground. Place the bypass capacitors as close to the power supply pins of the device as possible using low-impedance connections. TI recommends using multi-layer ceramic chip capacitors (MLCCs) that offer low equivalent series resistance (ESR) and inductance (ESL) characteristics for power-supply decoupling purposes. For very sensitive systems, or for systems in harsh noise environments, avoiding the use of vias for connecting the capacitors to the device pins may offer superior noise immunity. The use of multiple vias in parallel lowers the overall inductance and is beneficial for connections to ground planes.

11 Layout

11.1 Layout Guidelines

11.1.1 Layout Information

When a PCB trace turns a corner at a 90° angle, a reflection can occur. A reflection occurs primarily because of the change of width of the trace. At the apex of the turn, the trace width increases to 1.414 times the width. This increase upsets the transmission-line characteristics, especially the distributed capacitance and self-inductance of the trace which results in the reflection. Not all PCB traces can be straight and therefore some traces must turn corners. Figure 21 shows progressively better techniques of rounding corners. Only the last example (BEST) maintains constant trace width and minimizes reflections.

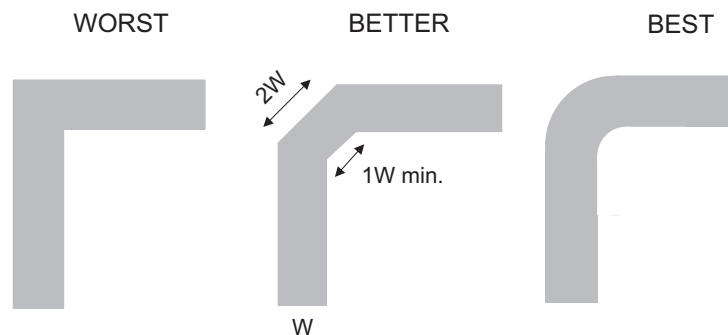

Figure 21. Trace Example

Route high-speed signals using a minimum of vias and corners which reduces signal reflections and impedance changes. When a via must be used, increase the clearance size around it to minimize its capacitance. Each via introduces discontinuities in the signal's transmission line and increases the chance of picking up interference from the other layers of the board. Be careful when designing test points, through-hole pins are not recommended at high frequencies.

Figure 22 illustrates an example of a PCB layout with the TMUX1219. Some key considerations are:

- Decouple the V_{DD} pin with a 0.1- μ F capacitor, placed as close to the pin as possible. Make sure that the capacitor voltage rating is sufficient for the V_{DD} supply.
- Keep the input lines as short as possible.
- Use a solid ground plane to help reduce electromagnetic interference (EMI) noise pickup.
- Do not run sensitive analog traces in parallel with digital traces. Avoid crossing digital and analog traces if possible, and only make perpendicular crossings when necessary.

11.2 Layout Example

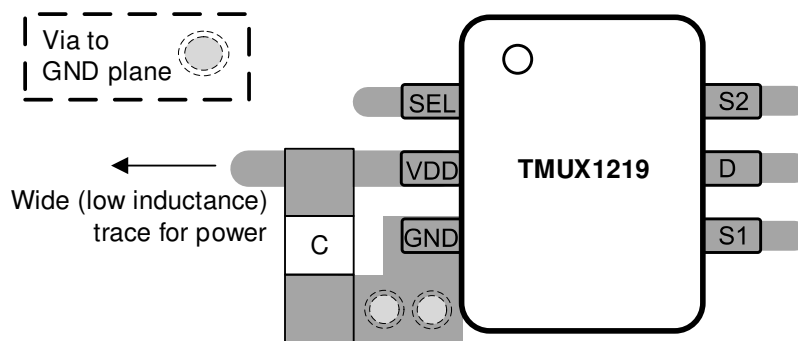

Figure 22. TMUX1219 Layout Example

12 Device and Documentation Support

12.1 Documentation Support

12.1.1 Related Documentation

Texas Instruments, [Improve Stability Issues with Low CON Multiplexers](#).

Texas Instruments, [Simplifying Design with 1.8 V Logic Muxes and Switches](#).

Texas Instruments, [Eliminate Power Sequencing with Powered-off Protection Signal Switches](#).

Texas Instruments, [System-Level Protection for High-Voltage Analog Multiplexers](#).

12.2 Receiving Notification of Documentation Updates

To receive notification of documentation updates, navigate to the device product folder on ti.com. In the upper right corner, click on *Alert me* to register and receive a weekly digest of any product information that has changed. For change details, review the revision history included in any revised document.

12.3 Community Resources

[TI E2E™ support forums](#) are an engineer's go-to source for fast, verified answers and design help — straight from the experts. Search existing answers or ask your own question to get the quick design help you need.

Linked content is provided "AS IS" by the respective contributors. They do not constitute TI specifications and do not necessarily reflect TI's views; see TI's [Terms of Use](#).

12.4 Trademarks

E2E is a trademark of Texas Instruments.

12.5 Electrostatic Discharge Caution



This integrated circuit can be damaged by ESD. Texas Instruments recommends that all integrated circuits be handled with appropriate precautions. Failure to observe proper handling and installation procedures can cause damage.

ESD damage can range from subtle performance degradation to complete device failure. Precision integrated circuits may be more susceptible to damage because very small parametric changes could cause the device not to meet its published specifications.

12.6 Glossary

[SLYZ022](#) — *TI Glossary*.

This glossary lists and explains terms, acronyms, and definitions.

13 Mechanical, Packaging, and Orderable Information

The following pages include mechanical, packaging, and orderable information. This information is the most current data available for the designated devices. This data is subject to change without notice and revision of this document. For browser-based versions of this data sheet, refer to the left-hand navigation.

PACKAGING INFORMATION

Orderable Device	Status (1)	Package Type	Package Drawing	Pins	Package Qty	Eco Plan (2)	Lead/Ball Finish (6)	MSL Peak Temp (3)	Op Temp (°C)	Device Marking (4/5)	Samples
TMUX1219DBVR	ACTIVE	SOT-23	DBV	6	3000	Green (RoHS & no Sb/Br)	NIPDAU	Level-1-260C-UNLIM	-40 to 125	26IT	Samples
TMUX1219DCKR	ACTIVE	SC70	DCK	6	3000	Green (RoHS & no Sb/Br)	NIPDAU	Level-1-260C-UNLIM	-40 to 125	1F5	Samples

(1) The marketing status values are defined as follows:

ACTIVE: Product device recommended for new designs.

LIFEBUY: TI has announced that the device will be discontinued, and a lifetime-buy period is in effect.

NRND: Not recommended for new designs. Device is in production to support existing customers, but TI does not recommend using this part in a new design.

PREVIEW: Device has been announced but is not in production. Samples may or may not be available.

OBSOLETE: TI has discontinued the production of the device.

(2) **RoHS:** TI defines "RoHS" to mean semiconductor products that are compliant with the current EU RoHS requirements for all 10 RoHS substances, including the requirement that RoHS substance do not exceed 0.1% by weight in homogeneous materials. Where designed to be soldered at high temperatures, "RoHS" products are suitable for use in specified lead-free processes. TI may reference these types of products as "Pb-Free".

RoHS Exempt: TI defines "RoHS Exempt" to mean products that contain lead but are compliant with EU RoHS pursuant to a specific EU RoHS exemption.

Green: TI defines "Green" to mean the content of Chlorine (Cl) and Bromine (Br) based flame retardants meet JS709B low halogen requirements of <=1000ppm threshold. Antimony trioxide based flame retardants must also meet the <=1000ppm threshold requirement.

(3) MSL, Peak Temp. - The Moisture Sensitivity Level rating according to the JEDEC industry standard classifications, and peak solder temperature.

(4) There may be additional marking, which relates to the logo, the lot trace code information, or the environmental category on the device.

(5) Multiple Device Markings will be inside parentheses. Only one Device Marking contained in parentheses and separated by a "-" will appear on a device. If a line is indented then it is a continuation of the previous line and the two combined represent the entire Device Marking for that device.

(6) Lead/Ball Finish - Orderable Devices may have multiple material finish options. Finish options are separated by a vertical ruled line. Lead/Ball Finish values may wrap to two lines if the finish value exceeds the maximum column width.

Important Information and Disclaimer:The information provided on this page represents TI's knowledge and belief as of the date that it is provided. TI bases its knowledge and belief on information provided by third parties, and makes no representation or warranty as to the accuracy of such information. Efforts are underway to better integrate information from third parties. TI has taken and continues to take reasonable steps to provide representative and accurate information but may not have conducted destructive testing or chemical analysis on incoming materials and chemicals. TI and TI suppliers consider certain information to be proprietary, and thus CAS numbers and other limited information may not be available for release.

In no event shall TI's liability arising out of such information exceed the total purchase price of the TI part(s) at issue in this document sold by TI to Customer on an annual basis.

TAPE AND REEL INFORMATION



QUADRANT ASSIGNMENTS FOR PIN 1 ORIENTATION IN TAPE



*All dimensions are nominal

Device	Package Type	Package Drawing	Pins	SPQ	Reel Diameter (mm)	Reel Width W1 (mm)	A0 (mm)	B0 (mm)	K0 (mm)	P1 (mm)	W (mm)	Pin1 Quadrant
TMUX1219DBVR	SOT-23	DBV	6	3000	178.0	9.0	2.4	2.5	1.2	4.0	8.0	Q3
TMUX1219DCKR	SC70	DCK	6	3000	178.0	9.0	2.4	2.5	1.2	4.0	8.0	Q3

TAPE AND REEL BOX DIMENSIONS

*All dimensions are nominal

Device	Package Type	Package Drawing	Pins	SPQ	Length (mm)	Width (mm)	Height (mm)
TMUX1219DBVR	SOT-23	DBV	6	3000	180.0	180.0	18.0
TMUX1219DCKR	SC70	DCK	6	3000	180.0	180.0	18.0

EXAMPLE BOARD LAYOUT

DBV0006A

SOT-23 - 1.45 mm max height

SMALL OUTLINE TRANSISTOR



LAND PATTERN EXAMPLE
EXPOSED METAL SHOWN
SCALE:15X



SOLDER MASK DETAILS

4214840/B 03/2018

NOTES: (continued)

- 6. Publication IPC-7351 may have alternate designs.
- 7. Solder mask tolerances between and around signal pads can vary based on board fabrication site.

EXAMPLE STENCIL DESIGN

DBV0006A

SOT-23 - 1.45 mm max height

SMALL OUTLINE TRANSISTOR



SOLDER PASTE EXAMPLE
BASED ON 0.125 mm THICK STENCIL
SCALE:15X

4214840/B 03/2018

NOTES: (continued)

8. Laser cutting apertures with trapezoidal walls and rounded corners may offer better paste release. IPC-7525 may have alternate design recommendations.
9. Board assembly site may have different recommendations for stencil design.

DCK (R-PDSO-G6)

PLASTIC SMALL-OUTLINE PACKAGE

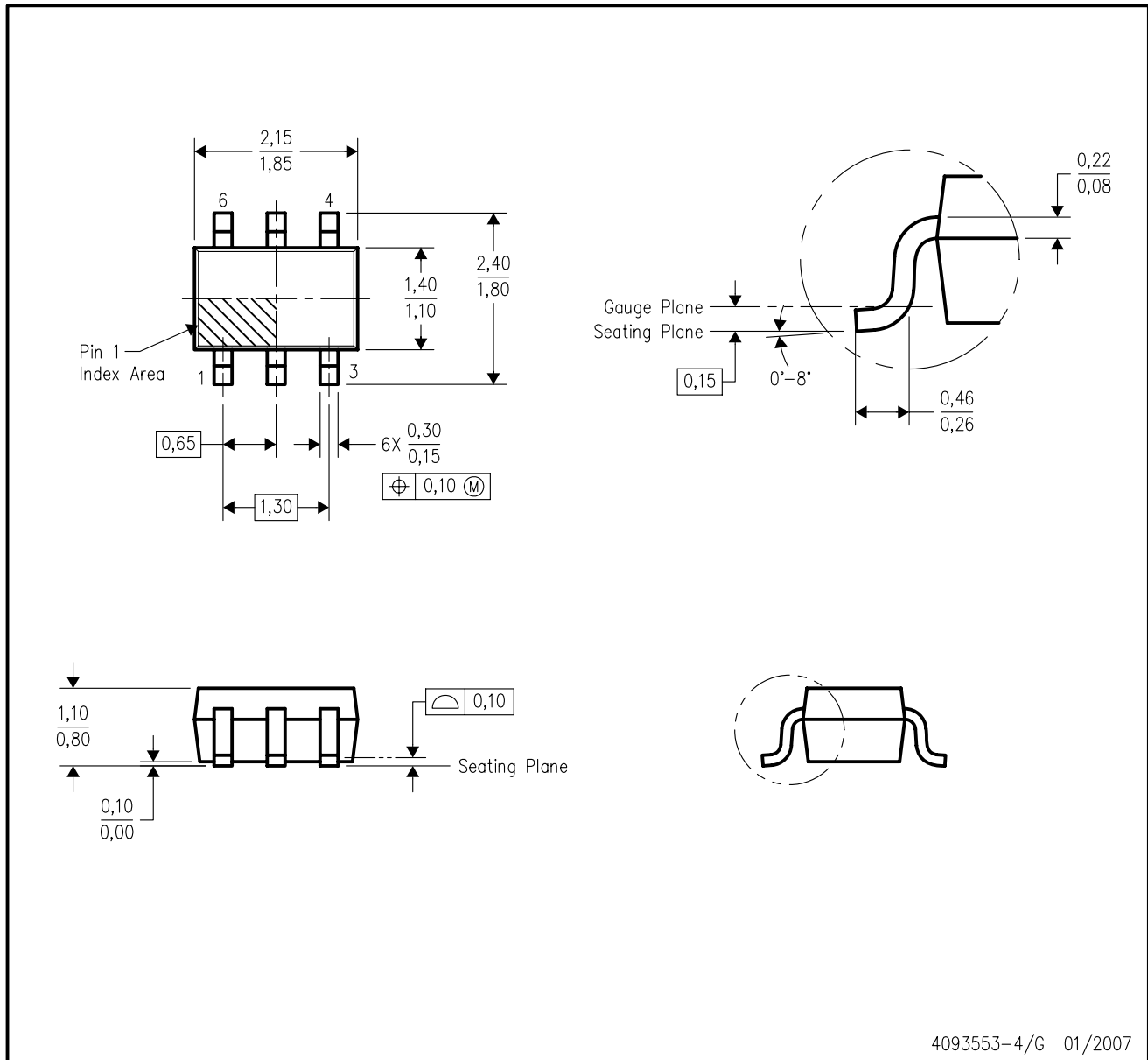

- NOTES:
- A. All linear dimensions are in millimeters.
 - B. This drawing is subject to change without notice.
 - C. Body dimensions do not include mold flash or protrusion. Mold flash and protrusion shall not exceed 0.15 per side.
 - D. Falls within JEDEC MO-203 variation AB.

DCK (R-PDSO-G6)

PLASTIC SMALL OUTLINE

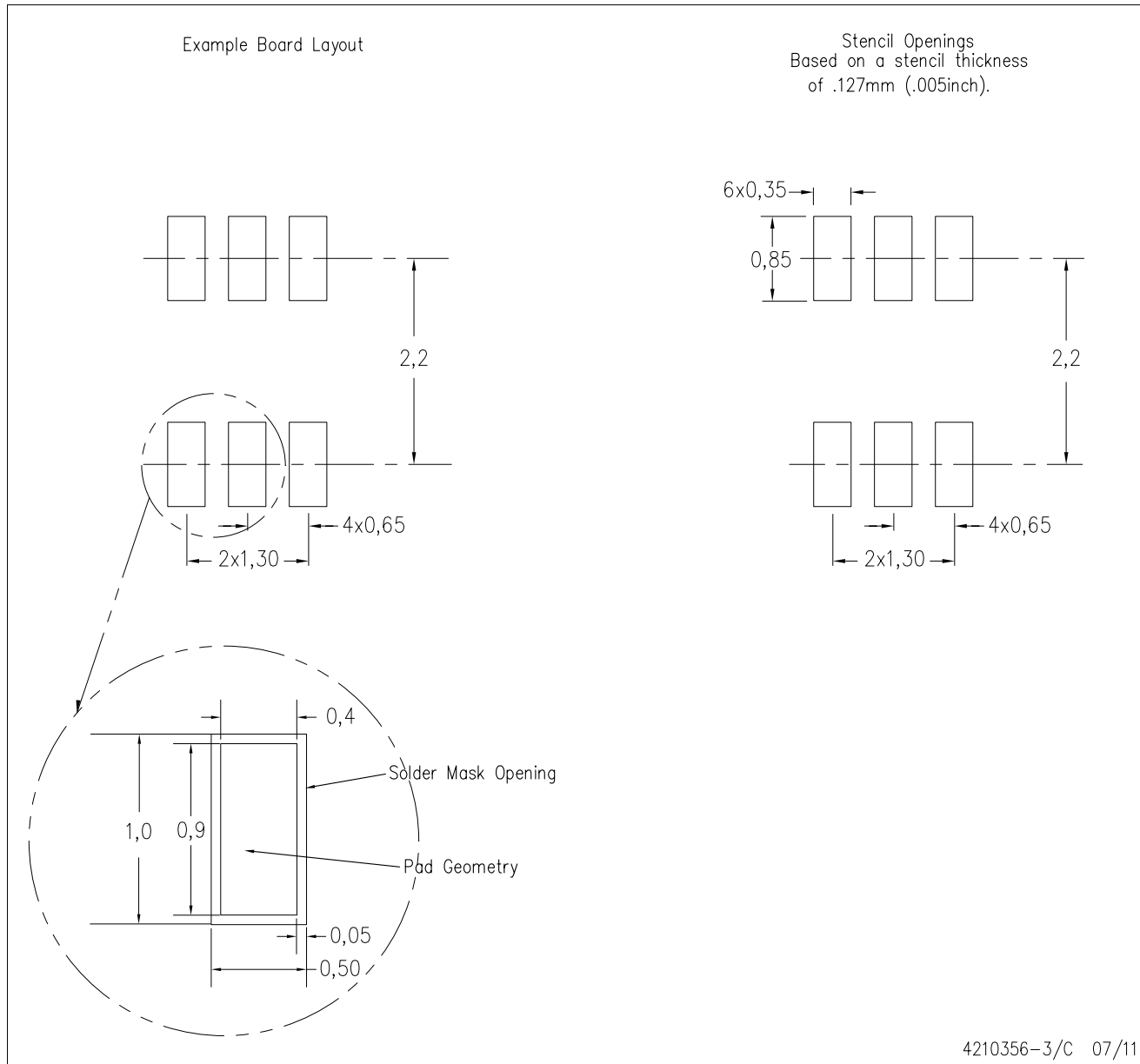

- NOTES:
- All linear dimensions are in millimeters.
 - This drawing is subject to change without notice.
 - Customers should place a note on the circuit board fabrication drawing not to alter the center solder mask defined pad.
 - Publication IPC-7351 is recommended for alternate designs.
 - Laser cutting apertures with trapezoidal walls and also rounding corners will offer better paste release. Customers should contact their board assembly site for stencil design recommendations. Example stencil design based on a 50% volumetric metal load solder paste. Refer to IPC-7525 for other stencil recommendations.

IMPORTANT NOTICE AND DISCLAIMER

TI PROVIDES TECHNICAL AND RELIABILITY DATA (INCLUDING DATASHEETS), DESIGN RESOURCES (INCLUDING REFERENCE DESIGNS), APPLICATION OR OTHER DESIGN ADVICE, WEB TOOLS, SAFETY INFORMATION, AND OTHER RESOURCES "AS IS" AND WITH ALL FAULTS, AND DISCLAIMS ALL WARRANTIES, EXPRESS AND IMPLIED, INCLUDING WITHOUT LIMITATION ANY IMPLIED WARRANTIES OF MERCHANTABILITY, FITNESS FOR A PARTICULAR PURPOSE OR NON-INFRINGEMENT OF THIRD PARTY INTELLECTUAL PROPERTY RIGHTS.

These resources are intended for skilled developers designing with TI products. You are solely responsible for (1) selecting the appropriate TI products for your application, (2) designing, validating and testing your application, and (3) ensuring your application meets applicable standards, and any other safety, security, or other requirements. These resources are subject to change without notice. TI grants you permission to use these resources only for development of an application that uses the TI products described in the resource. Other reproduction and display of these resources is prohibited. No license is granted to any other TI intellectual property right or to any third party intellectual property right. TI disclaims responsibility for, and you will fully indemnify TI and its representatives against, any claims, damages, costs, losses, and liabilities arising out of your use of these resources.

TI's products are provided subject to TI's Terms of Sale (www.ti.com/legal/termsofsale.html) or other applicable terms available either on ti.com or provided in conjunction with such TI products. TI's provision of these resources does not expand or otherwise alter TI's applicable warranties or warranty disclaimers for TI products.

Mailing Address: Texas Instruments, Post Office Box 655303, Dallas, Texas 75265
Copyright © 2020, Texas Instruments Incorporated