

# bq34110 Multi-Chemistry CEDV Battery Gas Gauge for Rarely Discharged Applications

## 1 Features

- Accurate End-Of-Service (EOS) Determination for Batteries in Rarely Discharged Applications
- Compensated End-of-Discharge Voltage (CEDV) Gas Gauge for Single- and Multi-Cell Batteries, Providing
  - State-Of-Charge (SOC)
  - Time-To-Empty (TTE)
  - State-Of-Health (SOH)
  - Watt-Hour–Based Charge Termination
- Supports Voltages up to 65 V, Capacities up to 32 Ah, and Currents up to 32 A—with Options to Extend Beyond These Levels Using Scaling
- Supports Li-Ion, LiFePO<sub>4</sub>, Lead-Acid (PbA), NiMH, and NiCd Chemistries
- Dual Configurable Host Interrupt or GPO
- Lifetime Data Logging Options
- Precision Coulomb Counter, Voltage, and Temperature Measurement
- Power Enable Control
- I<sup>2</sup>C™ Communication with Host
- Accumulated Charge Coulomb Counting with Configurable Interrupt
- SHA-1 Authentication

## 2 Applications

- UPS Backup Systems
- Telematics Backup Systems
- Emergency Battery Power Modules
- Energy Storage Systems
- Asset Tracking
- Building Security Systems
- Video Surveillance
- Electronic Smart Locks
- Remote and Emergency Lighting
- Server Power Systems
- Robotics
- Toys

## 3 Description

The bq34110 CEDV Battery Gas Gauge provides CEDV gas gauging and End-Of-Service (EOS) Determination for single- and multi-cell batteries. The device includes enhanced features to support applications where the battery is kept fully charged and is rarely discharged, such as found in a wide variety of backup systems. The bq34110 gas gauge supports multiple battery chemistries, including Li-Ion and LiFePO<sub>4</sub>, lead acid (PbA), Nickel Metal Hydride (NiMH), and Nickel Cadmium (NiCd).

The gas gauging function uses voltage, current, and temperature data with Compensated End-of-Discharge Voltage (CEDV) technology to provide State-Of-Charge (SOC) and State-Of-Health (SOH) data. The gas gauge also incorporates an End-Of-Service (EOS) Determination function that alerts when battery capability has degraded and is approaching the conclusion of its usable service.

The data available from the gauge can be read by the host through a 400-kHz I<sup>2</sup>C bus. Two ALERT outputs are also available to interrupt the host or can be used for other functions, based on a variety of configurable options.

### Device Information<sup>(1)</sup>

PART NUMBER	PACKAGE	BODY SIZE (NOM)
bq34110	TSSOP (14)	5.00 mm x 4.40 mm

(1) For all available packages, see the orderable addendum at the end of the data sheet.

### Simplified Schematic

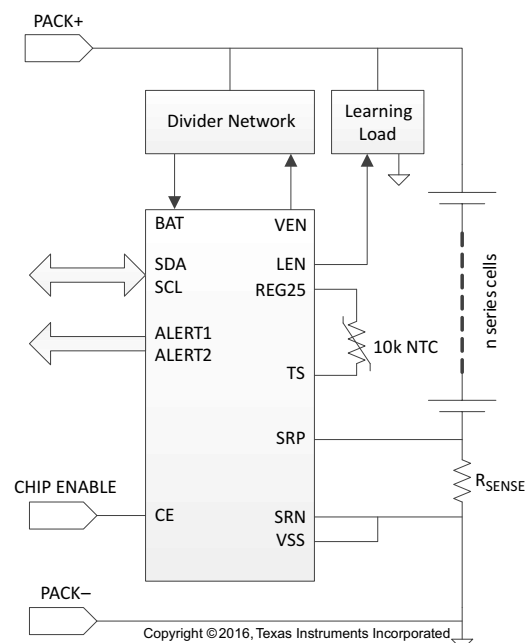

## Table of Contents

<b>1</b>	<b>Features</b> .....	<b>1</b>	6.14	Electrical Characteristics: Data Flash Memory .....	<b>7</b>
<b>2</b>	<b>Applications</b> .....	<b>1</b>	6.15	Timing Requirements: I <sup>2</sup> C-Compatible Interface Timing Characteristics .....	<b>7</b>
<b>3</b>	<b>Description</b> .....	<b>1</b>	6.16	Typical Characteristics .....	<b>8</b>
<b>4</b>	<b>Revision History</b> .....	<b>2</b>	<b>7</b>	<b>Detailed Description</b> .....	<b>9</b>
<b>5</b>	<b>Pin Configuration and Functions</b> .....	<b>3</b>	7.1	Overview .....	<b>9</b>
<b>6</b>	<b>Specifications</b> .....	<b>4</b>	7.2	Functional Block Diagram .....	<b>9</b>
6.1	Absolute Maximum Ratings .....	<b>4</b>	7.3	Feature Description .....	<b>9</b>
6.2	ESD Ratings .....	<b>4</b>	7.4	Device Functional Modes .....	<b>12</b>
6.3	Recommended Operating Conditions .....	<b>4</b>	<b>8</b>	<b>Application and Implementation</b> .....	<b>12</b>
6.4	Thermal Information .....	<b>4</b>	8.1	Application Information .....	<b>12</b>
6.5	Electrical Characteristics: Supply Current .....	<b>5</b>	8.2	Typical Applications .....	<b>13</b>
6.6	Electrical Characteristics: Digital Input and Output DC Characteristics .....	<b>5</b>	<b>9</b>	<b>Power Supply Recommendations</b> .....	<b>16</b>
6.7	Electrical Characteristics: Power-On Reset .....	<b>5</b>	<b>10</b>	<b>Layout</b> .....	<b>17</b>
6.8	Electrical Characteristics: LDO Regulator .....	<b>5</b>	10.1	Layout Guidelines .....	<b>17</b>
6.9	Electrical Characteristics: Internal Temperature Sensor .....	<b>6</b>	10.2	Layout Example .....	<b>18</b>
6.10	Electrical Characteristics: Low-Frequency Clock Oscillator .....	<b>6</b>	<b>11</b>	<b>Device and Documentation Support</b> .....	<b>20</b>
6.11	Electrical Characteristics: High-Frequency Clock Oscillator .....	<b>6</b>	11.1	Documentation Support .....	<b>20</b>
6.12	Electrical Characteristics: Integrating ADC (Coulomb Counter) .....	<b>6</b>	11.2	Receiving Notification of Documentation Updates .....	<b>20</b>
6.13	Electrical Characteristics: ADC (Temperature and Voltage Measurements) .....	<b>7</b>	11.3	Community Resources .....	<b>20</b>
			11.4	Trademarks .....	<b>20</b>
			11.5	Electrostatic Discharge Caution .....	<b>20</b>
			11.6	Glossary .....	<b>20</b>
			<b>12</b>	<b>Mechanical, Packaging, and Orderable Information</b> .....	<b>20</b>

## 4 Revision History

DATE	REVISION	NOTES
November 2016	B	PRODUCT PREVIEW to Production Data

## 5 Pin Configuration and Functions

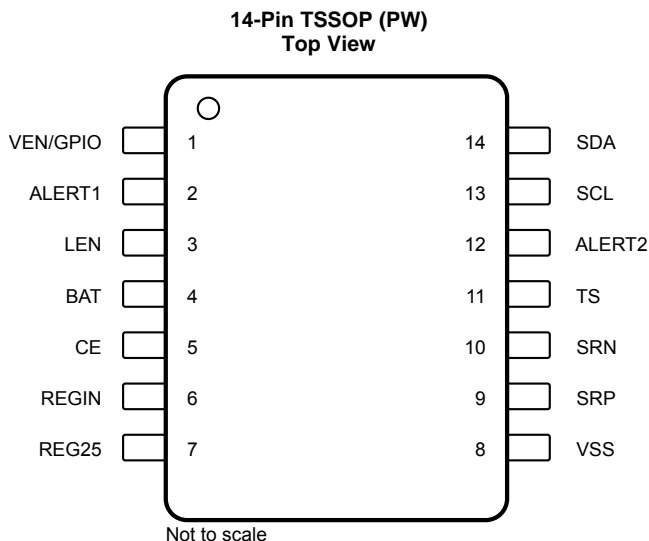

### Pin Functions

PIN		TYPE	DESCRIPTION
NAME	NUMBER		
VEN/GPIO	1	O <sup>(1)</sup>	Active High Voltage Translation Enable. This signal is used optionally to switch the input voltage divider on/off to reduce the power consumption (typ 45 $\mu$ A) of the divider network. It can also be used as a general purpose output.
ALERT1	2	O	Open drain output for use as system alert or charger control. Pull-up voltage limited
LEN	3	O	Push-pull external voltage divider control output
BAT	4	P	Voltage measurement input
CE	5	I	Chip enable. Internal LDO is powered down when driven low.
REGIN	6	P	Internal integrated LDO input. Decouple with 0.1- $\mu$ F ceramic capacitor to $V_{SS}$ .
REG25	7	P	2.5-V output voltage of the internal integrated LDO. Decouple with 1- $\mu$ F ceramic capacitor to $V_{SS}$ .
VSS	8	P	Device ground
SRP	9	I	Analog input pin connected to the internal coulomb-counter peripheral for integrating a small voltage between SRP and SRN, where SRP is nearest the BAT- connection.
SRN	10	I	Analog input pin connected to the internal coulomb-counter peripheral for integrating a small voltage between SRP and SRN, where SRN is nearest the PACK- connection.
TS	11	I	Pack thermistor voltage sense (use 103AT-type thermistor)
ALERT2	12	O	Open drain output for use as system alert or charger control
SCL	13	I	Open drain slave I <sup>2</sup> C serial communication clock input. Use with an external 10-k $\Omega$ pull-up resistor (typical).
SDA	14	I/O	Open drain slave I <sup>2</sup> C serial communication data line. Use with an external 10-k $\Omega$ pull-up resistor (typical).

(1) AI = Analog Input, O = Output, I = Input, P = Power, I/O = Input/Output

## 6 Specifications

### 6.1 Absolute Maximum Ratings

Over operating free-air temperature range (unless otherwise noted)<sup>(1)</sup>

		MIN	MAX	UNIT
V <sub>REGIN</sub>	Regulator input range	-0.3	5.5	V
V <sub>CE</sub>	CE input pin	-0.3	V <sub>REGIN</sub> + 0.3	V
V <sub>REG25</sub>	Supply voltage range	-0.3	2.75	V
V <sub>I<sub>OD</sub></sub>	Open-drain I/O pins (SDA, SCL, ALERT2)	-0.3	5.5	V
V <sub>BAT</sub>	BAT input pin	-0.3	5.5	V
V <sub>I</sub>	Input voltage range to all other pins (SRP, SRN, TS, ALERT1, VEN/GPIO, LEN)	-0.3	V <sub>REG25</sub> + 0.3	V
T <sub>A</sub>	Operating free-air temperature range	-40	85	°C
T <sub>J</sub>	Operating junction temperature range	-40	100	°C
T <sub>F</sub>	Functional temperature range	-40	100	°C
T <sub>STG</sub>	Storage temperature range	-65	150	°C
	Lead temperature (soldering, 10 s)	-40	100	°C

(1) Stresses beyond those listed under *Absolute Maximum Ratings* may cause permanent damage to the device. These are stress ratings only, which do not imply functional operation of the device at these or any other conditions beyond those indicated under *Recommended Operating Conditions*. Exposure to absolute-maximum-rated conditions for extended periods may affect device reliability.

### 6.2 ESD Ratings

		VALUE	UNIT
V <sub>(ESD)</sub>	Electrostatic discharge	Human-body model (HBM), per ANSI/ESDA/JEDEC JS-001, BAT pin <sup>(1)</sup>	±1500
		Human-body model (HBM), per ANSI/ESDA/JEDEC JS-001, all other pins <sup>(1)</sup>	±2000
		Charged-device model (CDM), per JEDEC specification JESD22-C101 <sup>(2)</sup>	±500

(1) JEDEC document JEP155 states that 500-V HBM allows safe manufacturing with a standard ESD control process.

(2) JEDEC document JEP157 states that 250-V CDM allows safe manufacturing with a standard ESD control process.

### 6.3 Recommended Operating Conditions

T<sub>A</sub> = -40°C to 85°C, V<sub>REGIN</sub> = V<sub>BAT</sub> = 3.6 V (unless otherwise noted)

		MIN	NOM	MAX	UNIT
V <sub>REGIN</sub>	Supply Voltage	No operating restrictions	2.7	4.5	V
		No FLASH writes	2.45	2.7	V
C <sub>REGIN</sub>	External input capacitor for internal LDO between REGIN and VSS	Nominal capacitor values specified. Recommend a 10% ceramic X5R type capacitor located close to the device.		0.1	µF
C <sub>REG25</sub>	External output capacitor for internal LDO between VCC	0.47	1		µF
t <sub>PUCD</sub>	Power-up communication			250	ms

### 6.4 Thermal Information

THERMAL METRIC <sup>(1)</sup>		bq34110		UNIT
		TSSOP (PW)		
		14 PINS		
R <sub>θJA</sub>	Junction-to-ambient thermal resistance	103.8		°C/W
R <sub>θJC(top)</sub>	Junction-to-case (top) thermal resistance	31.9		°C/W
R <sub>θJB</sub>	Junction-to-board thermal resistance	46.6		°C/W
ψ <sub>JT</sub>	Junction-to-top characterization parameter	2.0		°C/W
ψ <sub>JB</sub>	Junction-to-board characterization parameter	45.9		°C/W
R <sub>θJC(bot)</sub>	Junction-to-case (bottom) thermal resistance	N/A		°C/W

(1) For more information about traditional and new thermal metrics, see the *Semiconductor and IC Package Thermal Metrics* application report, [SPRA953](#).

## 6.5 Electrical Characteristics: Supply Current

 $T_A = -40^{\circ}\text{C}$  to  $85^{\circ}\text{C}$ ,  $V_{\text{REGIN}} = V_{\text{BAT}} = 3.6\text{ V}$  (unless otherwise noted)

PARAMETER		TEST CONDITIONS	MIN	TYP	MAX	UNIT
$I_{\text{CC\_NORMAL}}$	Normal operating current	Device in NORMAL mode, $I_{\text{LOAD}} > \text{Sleep Current}$		133		$\mu\text{A}$
$I_{\text{SNOOZE}}^{(1)}$	Sleep+ operation mode current	Device in SNOOZE mode, $I_{\text{LOAD}} < \text{Sleep Current}$		53		$\mu\text{A}$
$I_{\text{SLEEP}}^{(1)}$	Low-power SLEEP mode current	Device in SLEEP mode, $I_{\text{LOAD}} < \text{Sleep Current}$		22		$\mu\text{A}$
$I_{\text{SHUTDOWN}}$	SHUTDOWN mode current	Fuel gauge in SHUTDOWN mode, CE pin $< V_{\text{IL(CE) max}}$		0.01		$\mu\text{A}$

(1) Specified by design. Not production tested.

## 6.6 Electrical Characteristics: Digital Input and Output DC Characteristics

 $T_A = -40^{\circ}\text{C}$  to  $85^{\circ}\text{C}$ ,  $V_{\text{REGIN}} = V_{\text{BAT}} = 3.6\text{ V}$  (unless otherwise noted)

PARAMETER		TEST CONDITIONS	MIN	TYP	MAX	UNIT
$V_{\text{OL}}$	Output voltage, low (SCL, SDA, VEN, LEN, ALERT1, ALERT2 pins)	$I_{\text{OL}} = 3\text{ mA}$			0.4	V
$V_{\text{OH(PP)}}$	Output voltage, high	$I_{\text{OH}} = -1\text{ mA}$	$V_{\text{REG25}} - 0.5$			V
$V_{\text{OH(OD)}}$	Output voltage, high (SDA, SCL, ALERT1, ALERT2 pins)	External pull-up resistor connected to $V_{\text{REG25}}$	$V_{\text{REG25}} - 0.5$			V
$V_{\text{IH(ALERT1)}}$	Input voltage, high (ALERT1 pin)		1.2	$V_{\text{REG25}} + 0.3$		V
$V_{\text{IL}}$	Input voltage, low		-0.3		0.6	V
$V_{\text{IL(CE)}}$	Input voltage, low (CE pin)	$V_{\text{REGIN}} = 2.7\text{ to }4.5\text{ V}$			0.8	V
$V_{\text{IH(CE)}}$	Input voltage, high (CE pin)	$V_{\text{REGIN}} = 2.7\text{ to }4.5\text{ V}$	2.65			V
$V_{\text{IH(OD)}}$	Input voltage, high (SDA, SCL, ALERT2 pins)		1.2		5.5	V
$I_{\text{LKG}}$	Input leakage current (I/O pins)				0.3	$\mu\text{A}$

## 6.7 Electrical Characteristics: Power-On Reset

 $T_A = -40^{\circ}\text{C}$  to  $85^{\circ}\text{C}$ ; typical values at  $T_A = 25^{\circ}\text{C}$  and  $V_{\text{REGIN}} = 3.6\text{ V}$  (unless otherwise noted)

PARAMETER		TEST CONDITIONS	MIN	TYP	MAX	UNIT
$V_{\text{IT+}}$	Positive-going battery voltage input at REGIN			2.20		V
$V_{\text{HYS}}$	Power-on reset hysteresis			115		mV

## 6.8 Electrical Characteristics: LDO Regulator

 $T_A = 25^{\circ}\text{C}$ ,  $C_{\text{REG25}} = 1.0\text{ }\mu\text{F}$ ,  $V_{\text{REGIN}} = 3.6\text{ V}$  (unless otherwise noted)<sup>(1)</sup>

PARAMETER		TEST CONDITIONS	MIN	TYP	MAX	UNIT
$V_{\text{REG25}}$	Regulator output voltage	$2.7\text{ V} \leq V_{\text{REGIN}} \leq 4.5\text{ V}$ , $I_{\text{OUT}} \leq 16\text{ mA}$ $T_A = -40^{\circ}\text{C}$ to $85^{\circ}\text{C}$	2.3	2.5	2.7	V
		$2.45\text{ V} \leq V_{\text{REGIN}} < 2.7\text{ V}$ , $I_{\text{OUT}} \leq 3\text{ mA}$ $T_A = -40^{\circ}\text{C}$ to $85^{\circ}\text{C}$	2.3			
$I_{\text{SHORT}}^{(2)}$	Short circuit current limit	$V_{\text{REG25}} = 0\text{ V}$ $T_A = -40^{\circ}\text{C}$ to $85^{\circ}\text{C}$			250	mA

(1) LDO output current,  $I_{\text{OUT}}$ , is the total load current. Use the LDO regulator to power the internal fuel gauge only.

(2) Specified by design. Not production tested.

## 6.9 Electrical Characteristics: Internal Temperature Sensor

 $T_A = -40^\circ\text{C}$  to  $85^\circ\text{C}$ ,  $2.4\text{ V} < V_{\text{REG25}} < 2.6\text{ V}$ ; typical values at  $T_A = 25^\circ\text{C}$  and  $V_{\text{REG25}} = 2.5\text{ V}$  (unless otherwise noted)

PARAMETER		TEST CONDITIONS	MIN	TYP	MAX	UNIT
$G_{\text{TEMP}}$	Internal temperature sensor voltage gain			-2		mV/°C

## 6.10 Electrical Characteristics: Low-Frequency Clock Oscillator

 $T_A = -40^\circ\text{C}$  to  $85^\circ\text{C}$ ,  $2.4\text{ V} < V_{\text{REG25}} < 2.6\text{ V}$ ; typical values at  $T_A = 25^\circ\text{C}$  and  $V_{\text{REG25}} = 2.5\text{ V}$  (unless otherwise noted)

PARAMETER		TEST CONDITIONS	MIN	TYP	MAX	UNIT
$f_{\text{(LOSC)}}$	Operating frequency			32.768		kHz
$f_{\text{(EIO)}}$	Frequency error <sup>(1)(2)</sup>	$T_A = 0^\circ\text{C}$ to $60^\circ\text{C}$	-1.5%	0.25%	1.5%	
		$T_A = -20^\circ\text{C}$ to $70^\circ\text{C}$	-2.5%	0.25%	2.5%	
		$T_A = -40^\circ\text{C}$ to $85^\circ\text{C}$	-4%	0.25%	4%	
$t_{\text{(SXO)}}$	Start-up time <sup>(3)</sup>			500		μs

(1) The frequency drift is included and measured from the trimmed frequency at  $V_{\text{REG25}} = 2.5\text{ V}$ ,  $T_A = 25^\circ\text{C}$ .

(2) The frequency error is measured from 32.768 kHz.

(3) The start-up time is defined as the time it takes for the oscillator output frequency to be  $\pm 3\%$ .

## 6.11 Electrical Characteristics: High-Frequency Clock Oscillator

 $T_A = -40^\circ\text{C}$  to  $85^\circ\text{C}$ ,  $2.4\text{ V} < V_{\text{REG25}} < 2.6\text{ V}$ ; typical values at  $T_A = 25^\circ\text{C}$  and  $V_{\text{REG25}} = 2.5\text{ V}$  (unless otherwise noted)

PARAMETER		TEST CONDITIONS	MIN	TYP	MAX	UNIT
$f_{\text{(LOSC)}}$	Operating frequency			8.389		MHz
$f_{\text{(EIO)}}$	Frequency error <sup>(1)(2)</sup>	$T_A = 0^\circ\text{C}$ to $60^\circ\text{C}$	-2%	0.38%	2%	
		$T_A = -20^\circ\text{C}$ to $70^\circ\text{C}$	-3%	0.38%	3%	
		$T_A = -40^\circ\text{C}$ to $85^\circ\text{C}$	-4.5%	0.38%	4.5%	
$t_{\text{(SXO)}}$	Start-up time <sup>(3)</sup>				5	ms

(1) The frequency drift is included and measured from the trimmed frequency at  $V_{\text{REG25}} = 2.5\text{ V}$ ,  $T_A = 25^\circ\text{C}$ .

(2) The frequency error is measured from 8.389 MHz.

(3) The start-up time is defined as the time it takes for the oscillator output frequency to be  $\pm 3\%$ .

## 6.12 Electrical Characteristics: Integrating ADC (Coulomb Counter)

 $T_A = -40^\circ\text{C}$  to  $85^\circ\text{C}$ ,  $2.4\text{ V} < V_{\text{REG25}} < 2.6\text{ V}$ ; typical values at  $T_A = 25^\circ\text{C}$  and  $V_{\text{REG25}} = 2.5\text{ V}$  (unless otherwise noted)

PARAMETER		TEST CONDITIONS	MIN	TYP	MAX	UNIT
$V_{\text{(SR)}}$	Differential input voltage range	$V_{\text{(SR)}} = V_{\text{(SRP)}} - V_{\text{(SRN)}}$	-0.125		0.125	V
$V_{\text{(SRP)}}$ , $V_{\text{(SRN)}}$	Input voltage range, $V_{\text{(SRP)}}$ and $V_{\text{(SRN)}}$		-0.125		0.125	V
$t_{\text{SR\_CONV}}$	Conversion time	Single conversion		1		s
	Resolution		14		15	bits
$V_{\text{OS(SR)}}$	Input offset			10		μV
INL	Integral nonlinearity error			$\pm 0.007\%$		FSR <sup>(1)</sup>
$Z_{\text{IN(SR)}}$	Effective input resistance <sup>(2)</sup>		2.5			MΩ
$I_{\text{LKG(SR)}}$	Input leakage current <sup>(2)</sup>				0.3	μA

(1) Full-scale reference

(2) Specified by design. Not tested in production.

### 6.13 Electrical Characteristics: ADC (Temperature and Voltage Measurements)

 $T_A = -40^\circ\text{C}$  to  $85^\circ\text{C}$ ,  $2.4\text{ V} < V_{\text{REG25}} < 2.6\text{ V}$ ; typical values at  $T_A = 25^\circ\text{C}$  and  $V_{\text{REG25}} = 2.5\text{ V}$  (unless otherwise noted)

PARAMETER		TEST CONDITIONS	MIN	TYP	MAX	UNIT
$V_{\text{IN(ADC)}}$	ADC input voltage range for BAT measurement	Internal voltage divider inactive, internal $V_{\text{REF}}$	0.05		1	V
		Internal voltage divider activated, internal $V_{\text{REF}}$	0.05		4.5	V
	ADC input voltage for TS pin measurement		0		$V_{\text{REG25}}$	V
$t_{\text{ADC\_CONV}}^{(1)}$	Conversion time	Single conversion			125	ms
	Resolution		14		15	bits
$V_{\text{OS(ADC)}}$	Input offset			1		mV
$Z_{\text{ADC\_TS}}$	Effective input resistance (TS with internal pull-down activated) <sup>(1)</sup>			5		k $\Omega$
$Z_{\text{ADC\_BAT}}$	Effective input resistance (BAT) <sup>(1)</sup>	When not measuring cell voltage (internal voltage divider inactive)		8		M $\Omega$
		During measurement of cell voltage using internal divider (internal voltage divider active)		100		k $\Omega$
$I_{\text{LKG(ADC)}}$	Input leakage current <sup>(1)</sup>				0.3	$\mu\text{A}$

(1) Specified by design. Not tested in production.

### 6.14 Electrical Characteristics: Data Flash Memory

 $T_A = -40^\circ\text{C}$  to  $85^\circ\text{C}$ ,  $2.4\text{ V} < V_{\text{REG25}} < 2.6\text{ V}$ ; typical values at  $T_A = 25^\circ\text{C}$  and  $V_{\text{REG25}} = 2.5\text{ V}$  (unless otherwise noted)

PARAMETER		TEST CONDITIONS	MIN	TYP	MAX	UNIT
$t_{\text{DR}}$	Data retention <sup>(1)</sup>		10			Years
	Flash –programming write cycles <sup>(1)</sup>		20,000			Cycles
$t_{\text{WORDPROG}}$	Word programming time <sup>(1)</sup>				2	ms
$I_{\text{CCPROG}}$	Flash-write supply current <sup>(1)</sup>			5	10	mA

(1) Specified by design. Not tested in production.

### 6.15 Timing Requirements: I<sup>2</sup>C-Compatible Interface Timing Characteristics

 $T_A = -40^\circ\text{C}$  to  $85^\circ\text{C}$ ,  $2.4\text{ V} < V_{\text{REGIN}} = V_{\text{BAT}} < 5\text{ V}$ ; typical values at  $T_A = 25^\circ\text{C}$  and  $V_{\text{REGIN}} = V_{\text{BAT}} = 3.6\text{ V}$  (unless otherwise noted)

PARAMETER		TEST CONDITIONS	MIN	NOM	MAX	UNIT
$t_{\text{R}}$	SCL/SDA rise time				300	ns
$t_{\text{F}}$	SCL/SDA fall time				300	ns
$t_{\text{W(H)}}$	SCL pulse width (high)		600			ns
$t_{\text{W(L)}}$	SCL pulse width (low)		1.3			$\mu\text{s}$
$t_{\text{SU(STA)}}$	Setup for repeated start		600			ns
$t_{\text{d(STA)}}$	Start to first falling edge of SCL		600			ns
$t_{\text{SU(DAT)}}$	Data setup time		100			ns
$t_{\text{h(DAT)}}$	Data hold time		0			ns
$t_{\text{SU(STOP)}}$	Setup time for stop		600			ns
$t_{\text{BUF}}$	Bus free time between stop and start		66			$\mu\text{s}$
$f_{\text{SCL}}$	Clock frequency				400	kHz

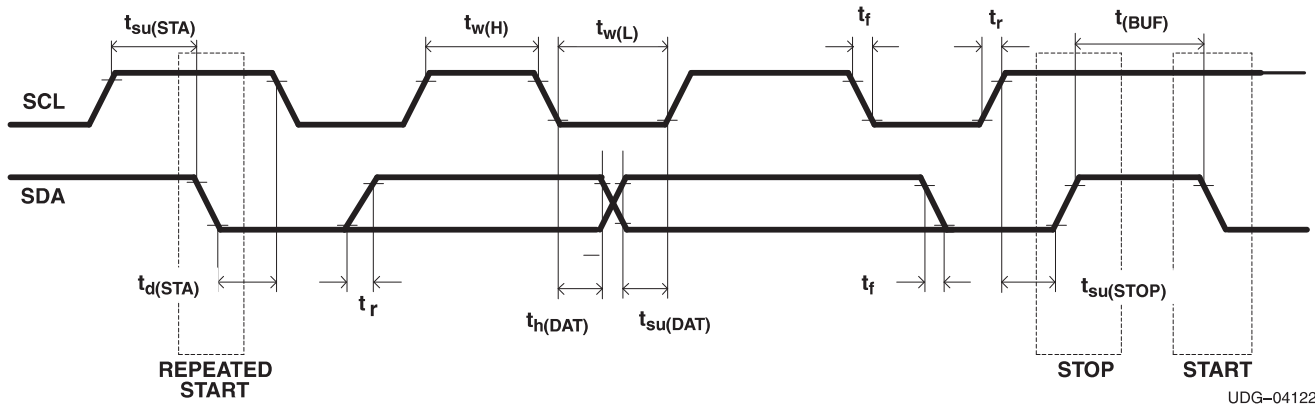

Figure 1. I<sup>2</sup>C-Compatible Interface Timing Diagram

### 6.16 Typical Characteristics

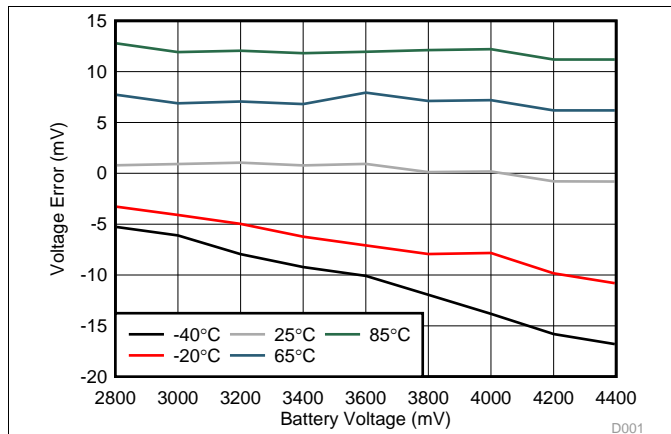

Figure 2.  $V_{(Err)}$  Across  $V_{IN}$  (0 mA)

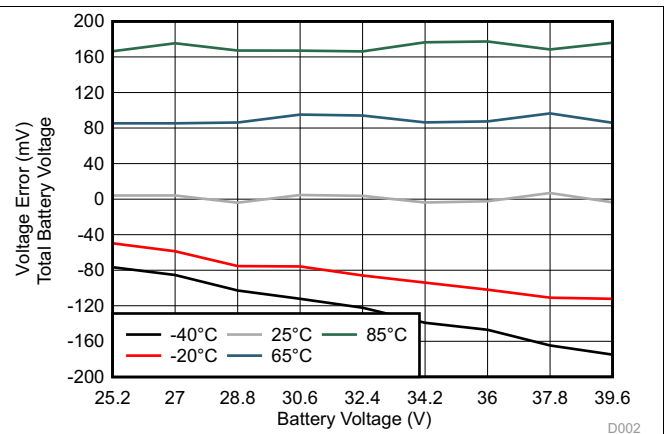

Figure 3.  $V_{(Err)}$  Across  $V_{IN}$  (0 mA) for a 9-Series Configuration

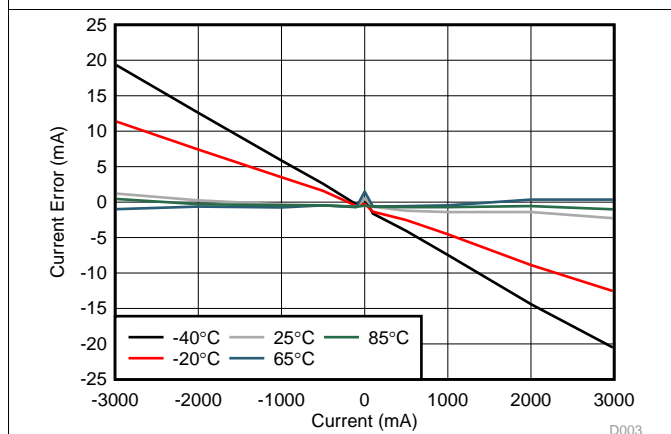

Figure 4.  $I_{(Err)}$

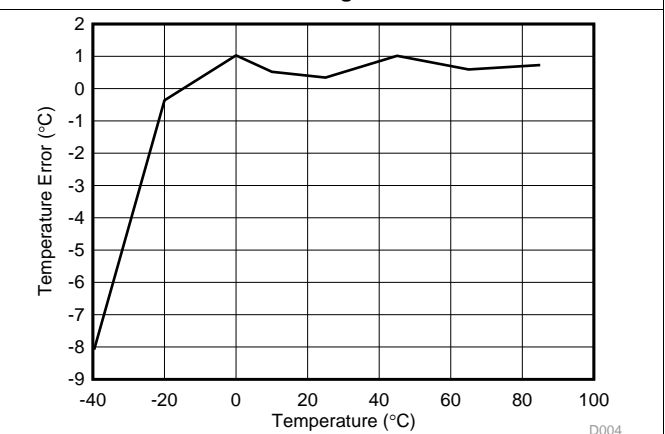

Figure 5.  $T_{(Err)}$



## 7 Detailed Description

### 7.1 Overview

The bq34110 device incorporates multiple capabilities to provide detailed and sophisticated information on single-cell and multi-cell battery packs. Several different battery chemistries are supported, including Li-Ion, LiFePO4, lead-acid (PbA), Nickel Metal Hydride (NiMH), and Nickel Cadmium (NiCd). The device integrates a gas gauge for monitoring battery charge level, an End-Of-Service (EOS) Determination function to evaluate when a battery is nearing the end of its usable life, a specialized **WHR Charge Termination** function to enable battery charging to a targeted energy capacity, a charge control scheme using direct pin control, SHA-1/HMAC-based authentication, and lifetime data logging functionality.

#### NOTE

Formatting Conventions in This Document:

**Commands:** *italics* with parentheses and no breaking spaces; for example, *Control()*

**Data Flash:** *italics*, **bold**, and breaking spaces; for example, ***Design Capacity***

**Register Bits and Flags:** brackets only; for example, [TDA]

**Data Flash Bits:** *italic* and **bold**; for example, ***[XYZ1]***

**Modes and States:** ALL CAPITALS; for example, UNSEALED mode

### 7.2 Functional Block Diagram

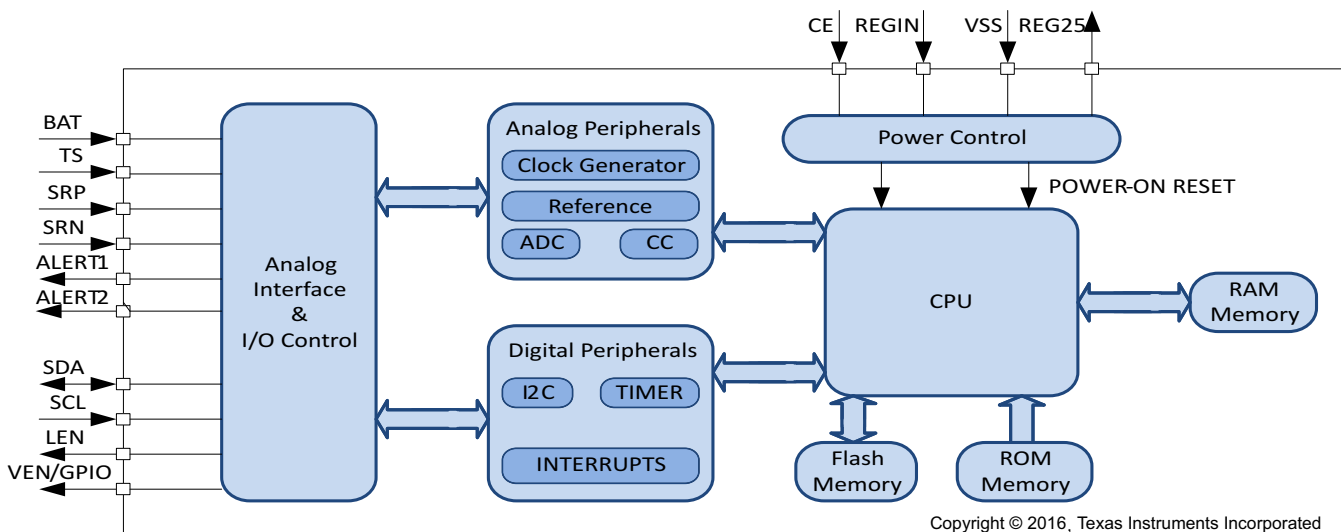

### 7.3 Feature Description

The bq34110 gas gauge uses Compensated End-of-Discharge Voltage (CEDV) technology to accurately predict the battery capacity and other operational characteristics of the battery, and can be interrogated by a host processor to provide cell information, such as remaining capacity, full charge capacity, and average current.

The integrated End-Of-Service (EOS) Determination function is specifically intended for applications where the battery is rarely discharged, such as in uninterruptible power supplies (UPS), enterprise server backup systems, and telecommunications backup modules. In such systems, the battery may remain in a fully (or near-fully) charged state for much of its lifetime, with it rarely or never undergoing a significant discharge. If the health of the battery in such a system is not monitored regularly, then it may degrade beyond the level required for a system backup/discharge event, and thus fail precisely at the time when it is needed most.

## Feature Description (continued)

The EOS Determination function monitors the health of the battery through the use of infrequent Learning Phases, which involves a controlled discharge of ~1% capacity, and provides an alert to the system when the battery is approaching the end of its usable service. By coordinating battery charging with the Learning Phases, the battery capacity available to the system can be maintained above a preselected level to avoid compromising the ability for the battery to support a system discharge event.

The bq34110 device can support multi-cell battery configurations with maximum voltage up to 65 V through the use of external and internal resistive divider networks to reduce the voltage to an acceptable range for the device's integrated ADC. These resistive dividers are actively controlled to avoid unnecessary power dissipation when not needed. The device integrates an internal temperature sensor as well as support for an external NTC thermistor, such as a Semitec 103AT or Mitsubishi BN35-3H103FB-50.

The battery current is monitored by measuring the voltage across a series resistor,  $R_{SENSE}$ , which is placed in series with the battery pack and has a typical value of 5 m $\Omega$  to 20 m $\Omega$ . The bq34110 device integrates two ADCs, one of which is dedicated to current measurement, and the second used for measurement of several other parameters, including temperature and voltage.

Communication with the device is provided through an I<sup>2</sup>C interface, supporting rates up to 400 kHz. Dual ALERT pins are provided with programmable configuration, which enables them to be used for such functions as a host interrupt/alert or controlling the battery charger.

To minimize power consumption, the bq34110 gauge has several power modes: NORMAL, SNOOZE, and SLEEP, which are under register or algorithm control. In addition, a separate chip enable (CE) pin is provided to control the internal LDO, which powers the bq34110 internal circuitry, and can put the device into SHUTDOWN mode.

Information is accessed through a series of commands called Data Commands, which are indicated by the general format *Command()*. These commands are used to read and write information in the bq34110 device's control and status registers, as well as its data flash locations.

Commands are sent from the host to the bq34110 device via I<sup>2</sup>C and can be executed during application development, pack manufacture, or end-equipment operation. Cell information is stored in the bq34110 device in non-volatile flash memory. Many of the data flash locations are accessible during application development and pack manufacture. They cannot, generally, be accessed directly during end-equipment operation. Access to these locations is achieved by using the bq34110 device's companion evaluation software, through individual commands, or through a sequence of data flash access commands. To access a desired data flash location, the correct data flash subclass and offset must be known.

The bq34110 device provides 32 bytes of user-programmable data flash memory. This data space is accessed through a data flash interface. For specifics on accessing the data flash, see the *bq34110 Technical Reference Manual (SLUUBF7)*.

A SHA-1/HMAC-based battery pack authentication feature is also implemented on the bq34110 device. When the device is in UNSEALED mode, authentication keys can be (re)assigned. A scratch pad area is used to receive challenge information from a host and to export SHA-1/HMAC encrypted responses. For more information on authentication, see the *bq34110 Technical Reference Manual (SLUUBF7)*.

### 7.3.1 Communications

#### 7.3.1.1 I<sup>2</sup>C Interface

The bq34110 device supports the standard I<sup>2</sup>C read, incremental read, one-byte write quick read, and functions. The 7-bit device address (ADDR) is the most significant 7 bits of the hex address and is fixed as 1010101. The 8-bit device address is therefore 0xAA or 0xAB for write or read, respectively.

Feature Description (continued)

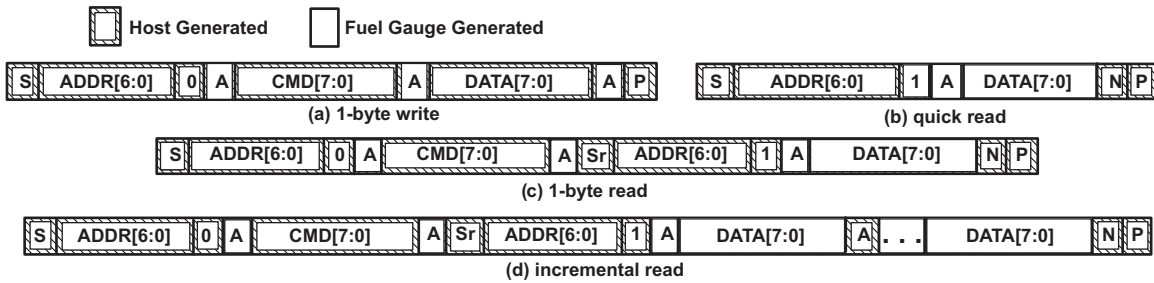

Figure 6. Supported I<sup>2</sup>C formats: (a) 1-byte write, (b) quick read, (c) 1 byte-read, and (d) incremental read (S = Start, Sr = Repeated Start, A = Acknowledge, N = No Acknowledge, and P = Stop).

The “quick read” returns data at the address indicated by the address pointer. The address pointer, a register internal to the I<sup>2</sup>C communication engine, increments whenever data is acknowledged by the device or the I<sup>2</sup>C master. “Quick writes” function in the same manner and are a convenient means of sending multiple bytes to consecutive command locations (such as 2-byte commands that require two bytes of data).



Figure 7. Attempt to Write a Read-Only Address (Nack After Data Sent By Master)



Figure 8. Attempt to Read an Address Above 0x7F (NACK Command)



Figure 9. Attempt at Incremental Writes (Nack All Extra Data Bytes Sent)

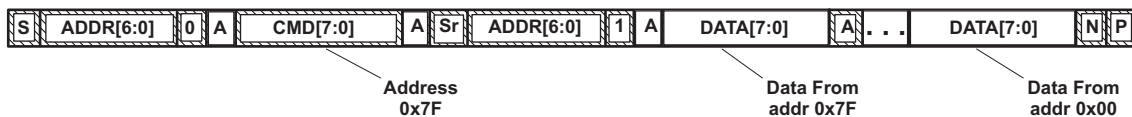

Figure 10. Incremental Read at the Maximum Allowed Read Address

7.3.1.2 I<sup>2</sup>C Time Out

The I<sup>2</sup>C engine releases both SDA and SCL if the I<sup>2</sup>C bus is held low for a time programmed in data flash. If the device were holding the lines, releasing them frees the master to drive the lines.

Detailed examples of I<sup>2</sup>C transactions accessing gauge data can be found in the *Using I<sup>2</sup>C Communication with the bq275xx Series of Fuel Gauges Application Report (SLUA467)*.

## 7.4 Device Functional Modes

The bq34110 device has four functional power modes: NORMAL, SNOOZE, SLEEP, and SHUTDOWN, based on firmware and/or host control.

- In NORMAL mode, the device is fully powered and can execute any allowable task.
- In SNOOZE mode, the device periodically wakes to take data measurements and updates the data set, after which it then returns directly to SNOOZE.
- In SLEEP mode, the device maintains the low-frequency oscillator but turns off the high-frequency oscillator and exists in a reduced-power state, periodically taking measurements and performing calculations.
- In SHUTDOWN mode, the device is fully powered down and can only be awakened using the chip enable (CE) pin.

## 8 Application and Implementation

---

### NOTE

Information in the following applications sections is not part of the TI component specification, and TI does not warrant its accuracy or completeness. TI's customers are responsible for determining suitability of components for their purposes. Customers should validate and test their design implementation to confirm system functionality.

---

### 8.1 Application Information



The bq34110 gas gauge is a highly configurable device with multiple features that can be used individually or simultaneously (with some restrictions). The CEDV gas gauging function together with its support for an external voltage divider allows gauging of high voltage, multi-cell battery configurations of various chemistries. The EOS Determination function is intended for rarely discharged applications and evaluates the condition of the battery without requiring conventional maintenance cycles. These and additional features are described in detail in the *bq34110 Technical Reference Manual* ([SLUUBF7](#)).

## 8.2 Typical Applications

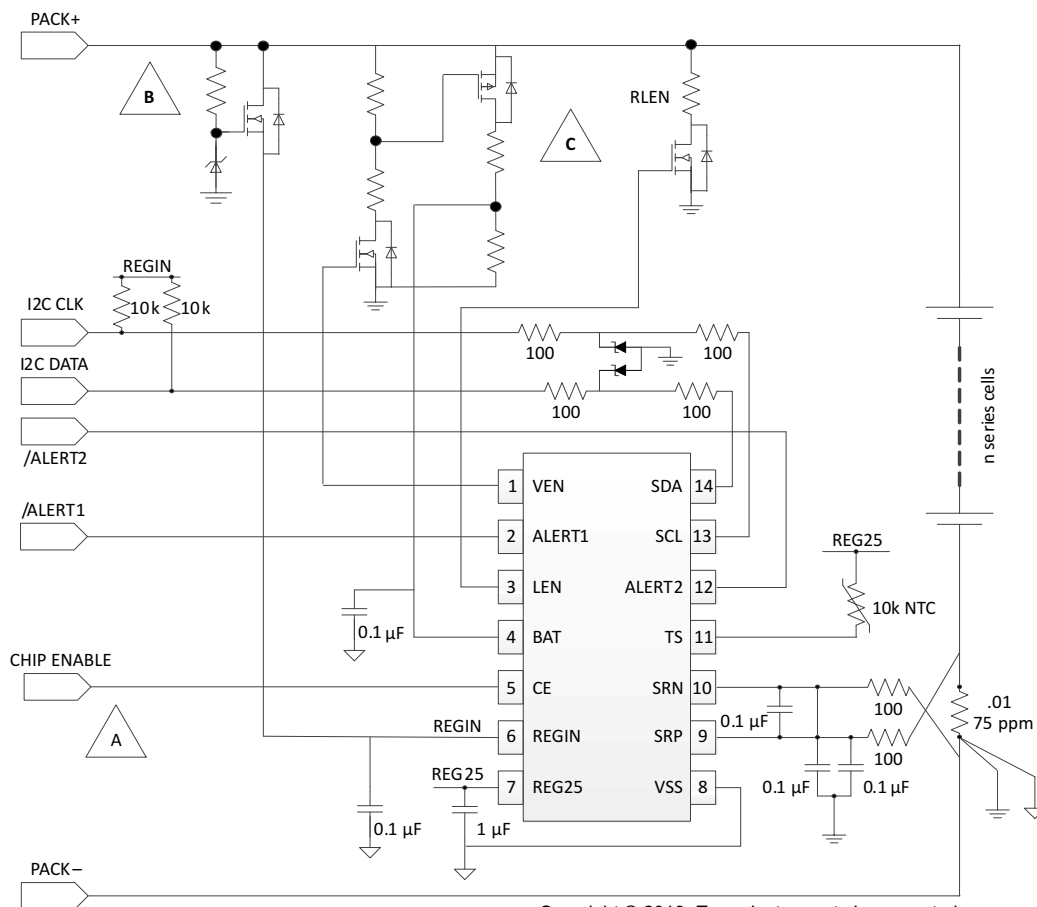
Figure 11 is a simplified schematic of the bq34110 system used in a multi-cell configuration.



Copyright © 2016, Texas Instruments Incorporated

-  If power control of the gauge is not required by the system, then CE should be connected directly to REGIN.
-  Required for applications of more than one-series cell; otherwise, REGIN can connect directly to single-cell BAT+ or an alternative power source.
-  Required for applications of more than one-series cell; otherwise, BAT connects directly to single-cell BAT+ and VEN can be left unconnected.

**Figure 11. bq34110 Simplified System Diagram**

## Typical Applications (continued)

Figure 12 shows the schematic of the bq34110 EVM, and depicts how the device can be used in the system.

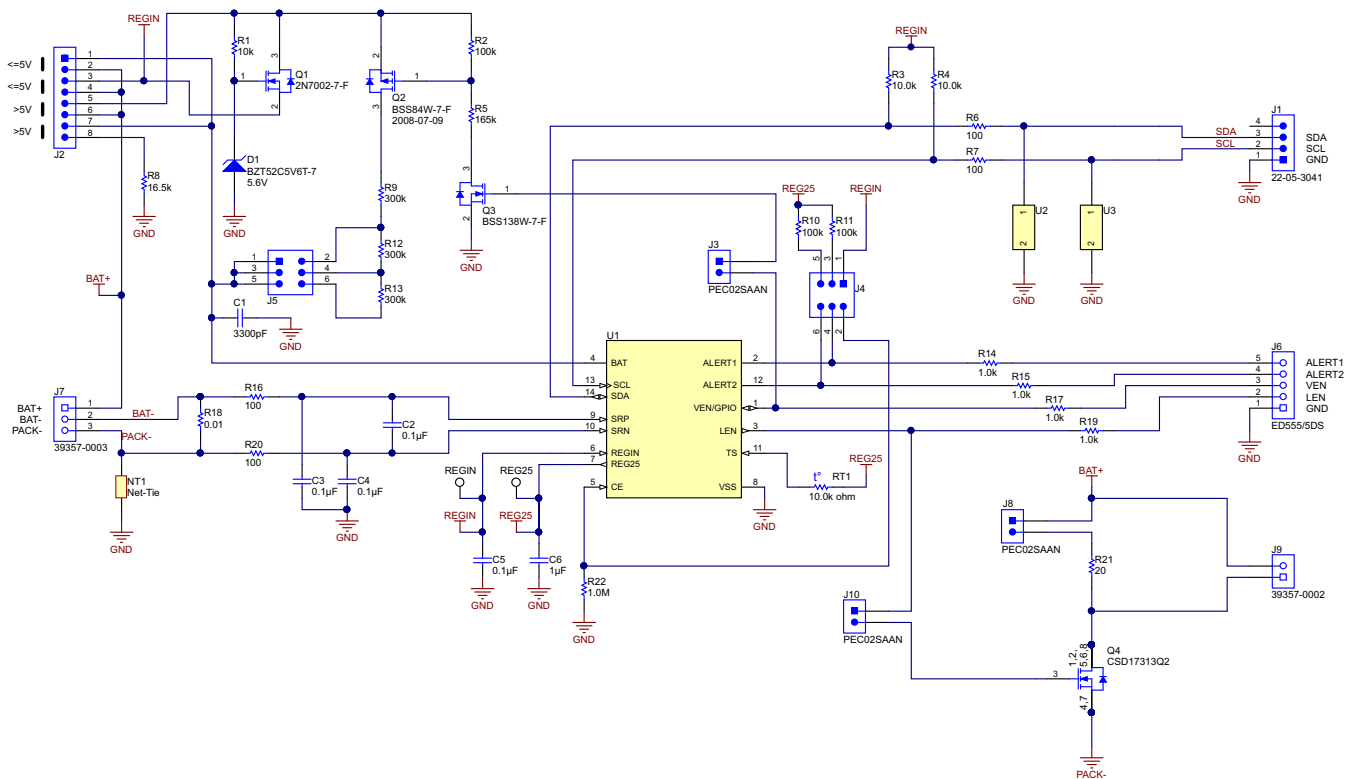

Copyright © 2016, Texas Instruments Incorporated

Figure 12. bq34110 EVM Schematic

### 8.2.1 Design Requirements

The bq34110 device supports several circuit configuration options that can be decided upon during the system design phase. Using the device with a single-cell battery versus a multi-cell configuration determines if there is a need for a battery divider and associated control using the VEN pin (as shown in Figure 11). The functions used within the bq34110 device also determine the pin usage, with the device incorporating flexibility to reuse pins for other purposes if the system configuration permits. For example, if a single-cell configuration is selected, then the VEN pin can be used as part of a direct charge control scheme. Similarly, the LEN, ALERT1, and/or ALERT2 pins can also be repurposed to support direct charge control. For additional design guidelines, refer to the *bq34110 EVM User's Guide (SLUUBI1)*.

### 8.2.2 Detailed Design Procedure

#### 8.2.2.1 BAT Voltage Sense Input

A ceramic capacitor at the input to the BAT pin is used to bypass AC voltage ripple to ground, greatly reducing its influence on battery voltage measurements. It proves most effective in applications with load profiles that exhibit high-frequency current pulses (that is, cell phones) but is recommended for use in all applications to reduce noise on this sensitive high-impedance measurement node. If the device is used in a multi-cell configuration with an external resistive voltage divider, it is recommended that the resistors used therein be selected with temperature coefficient of resistance (TCR) of 75-ppm or below. More detail on the design of the voltage divider network is discussed in the *bq34110 Technical Reference Manual (SLUUBF7)*.

## Typical Applications (continued)

### 8.2.2.2 SRP and SRN Current Sense Inputs

The filter network at the input to the coulomb counter is intended to improve differential mode rejection of voltage measured across the sense resistor. These components should be placed as close as possible to the coulomb counter inputs, and the routing of the differential traces length-matched to best minimize impedance mismatch-induced measurement errors.

### 8.2.2.3 Sense Resistor Selection

Any variation encountered in the resistance present between the SRP and SRN pins of the fuel gauge will affect the resulting differential voltage, and derived current, it senses. As such, it is recommended to select a sense resistor with minimal tolerance and temperature coefficient of resistance (TCR) characteristics. The standard recommendation based on the best compromise between performance and price is a 1% tolerance, 75-ppm drift sense resistor with a 1-W power rating.

### 8.2.2.4 TS Temperature Sense Input

Similar to the BAT pin, a ceramic decoupling capacitor for the TS pin is used to bypass AC voltage ripple away from the high-impedance ADC input, minimizing measurement error. It should be placed as close as possible to the respective input pin for optimal filtering performance.

### 8.2.2.5 Thermistor Selection

The fuel gauge temperature sensing circuitry is designed to work with a negative temperature coefficient-type (NTC) thermistor with a characteristic 10-k $\Omega$  resistance at room temperature (25°C). The default curve-fitting coefficients configured in the fuel gauge specifically assume a 103AT-2 type thermistor profile and so that is the default recommendation for thermistor selection purposes. Moving to a separate thermistor resistance profile (for example, JT-2 or others) requires an update to the default thermistor coefficients in data flash to ensure highest accuracy temperature measurement performance.

### 8.2.2.6 REGIN Power Supply Input Filtering

A ceramic capacitor is placed at the input to the fuel gauge internal LDO to increase power supply rejection (PSR) and improve effective line regulation. It ensures that voltage ripple is rejected to ground instead of coupling into the internal supply rails of the fuel gauge.

### 8.2.2.7 REG25 LDO Output Filtering

A ceramic capacitor is also needed at the output of the internal LDO to provide a current reservoir for fuel gauge load peaks during high peripheral utilization. It acts to stabilize the regulator output and reduce core voltage ripple inside the fuel gauge.

## Typical Applications (continued)

### 8.2.3 Application Curves

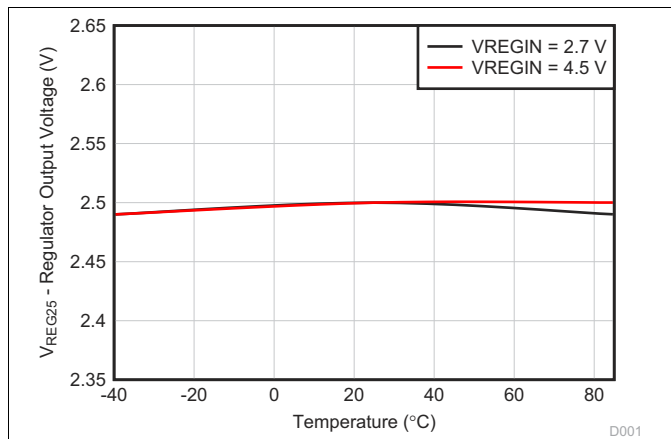

Figure 13. Regulator Output Voltage vs. Temperature

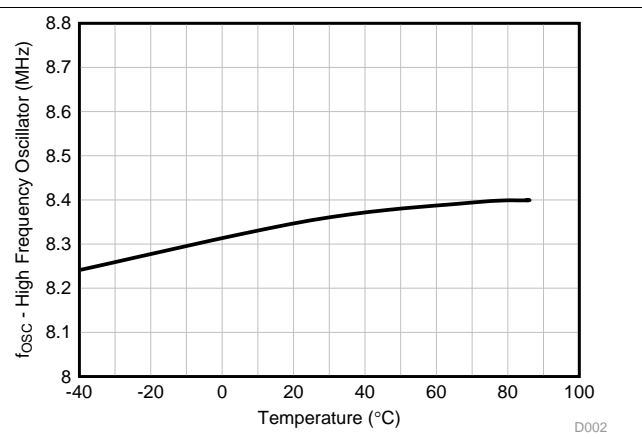

Figure 14. High-Frequency Oscillator Frequency vs. Temperature

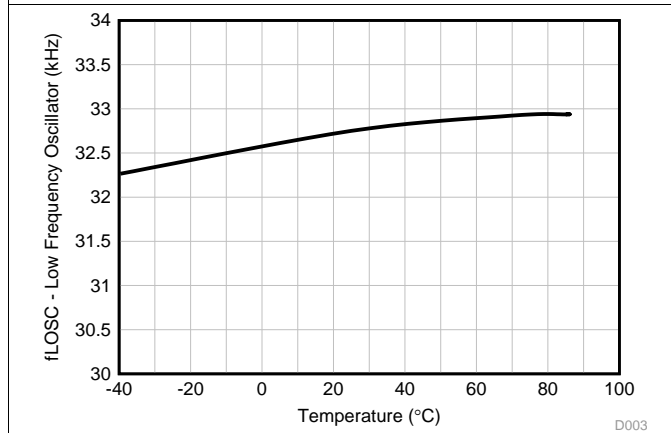

Figure 15. Low-Frequency Oscillator Frequency vs. Temperature

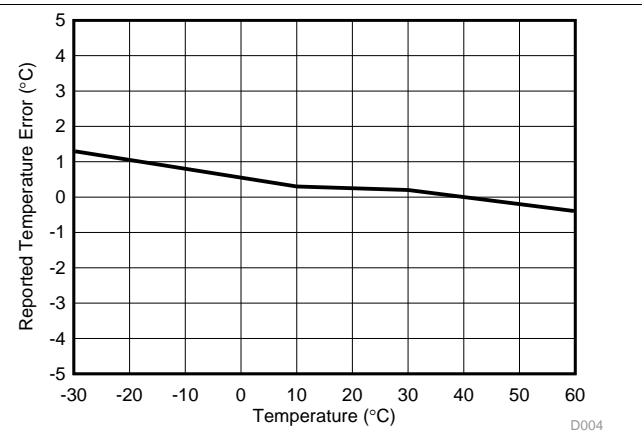

Figure 16. Reported Internal Temperature Measurement vs. Temperature

## 9 Power Supply Recommendations

Power supply requirements for the bq34110 device are simplified due to the presence of the internal LDO-voltage regulation. The REGIN pin accepts any voltage level between 2.7 V and 4.5 V, which is optimum for a single-cell Li-Ion application. For higher battery voltage applications, a simple preregulator can be provided to power the bq34110 device. Decoupling the REGIN pin should be done with a 0.1- $\mu$ F 10% ceramic X5R capacitor placed close to the device. While the preregulator circuit is not critical, special attention should be paid to its quiescent current and power dissipation. The input voltage should handle the maximum battery stack voltage. The output voltage can be centered within the 2.7-V to 4.5-V range as recommended for the REGIN pin.

For high stack count applications, a commercially available LDO is often the best quality solution, but comes with a cost tradeoff. To lower the BOM cost, the following approaches are recommended.

In [Figure 17](#), Q1 is used to drop the battery stack voltage to roughly 4 V to power the bq34110 device's REGIN pin. To avoid unwanted quiescent current consumption, R1 should be set as high as is practical. It is recommended to use a low-current Zener diode.



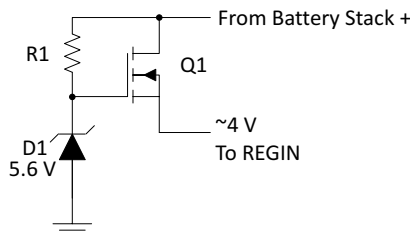

Figure 17. Q1 Dropping Battery Stack Voltage to 4 V

Alternatively, if the range of a high-voltage battery stack can be well-defined, a simple source follower based on a resistive divider can be used to lower the BOM cost and the quiescent current. For example:

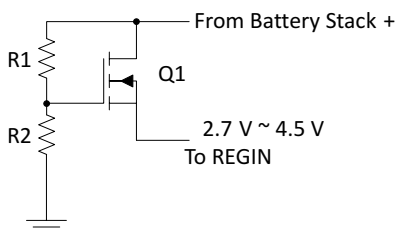

Figure 18. Source Follower on a Resistive Divider

## 10 Layout

### 10.1 Layout Guidelines

Attention to layout is critical to the success of any battery management circuit board. The mixture of high-current paths with an ultralow-current microcontroller creates the potential for design issues that are not always trivial to solve. Some of the key areas of concern are described in the following sections and can help to enable success.

#### 10.1.1 Power Supply Decoupling Capacitor

Power supply decoupling from REG25 to ground is important for optimal operation of the gas gauge. To keep the loop area small, place this capacitor next to the IC and use the shortest possible traces. A large loop area renders the capacitor useless and forms a small-loop antenna for noise pickup. Ideally, the traces on each side of the capacitor should be the same length and run in the same direction to avoid differential noise during ESD. If possible, place a via near the VSS pin to a ground plane layer.

#### 10.1.2 Capacitors

Power supply decoupling for the gas gauge requires 0.1- $\mu$ F ceramic capacitors for the BAT and REGIN pins. These should be placed reasonably close to the IC without using long traces back to VSS. The LDO voltage regulator, whether external or internal to the main IC, requires a 1- $\mu$ F ceramic capacitor to be placed fairly close to the regulation output pin (REG25). This capacitor is for amplifier loop stabilization and as an energy well for the 2.5-V supply.

#### 10.1.3 Communication Line Protection Components

5.6-V Zener diodes are included on the I<sup>2</sup>C lines to protect the communication pins of the gas gauge from ESD. These diodes should be located as close as possible to the pack connector. The grounded end of these Zener diodes should be returned to the PACK(-) node rather than to the low-current digital ground system. This way, ESD is diverted away from the sensitive electronics as much as possible.

## 10.2 Layout Example

### 10.2.1 Ground System

The gas gauge requires a low-current ground system separate from the high-current PACK(–) path. ESD ground is defined along the high-current path from the PACK(–) terminal to the sense resistor. It is important that the low-current ground systems only connect to the PACK(–) path at the sense resistor Kelvin pick-off point. It is recommended to use an optional inner layer ground plane for the low-current ground system.

In [Figure 19](#), the green area shows an example of using the low-current ground as a shield for the gas gauge circuit. Notice how it is kept separate from the high-current ground, which is shown in red. The high current path is joined with the low-current path only at one point, shown with the small blue connection between the two planes.

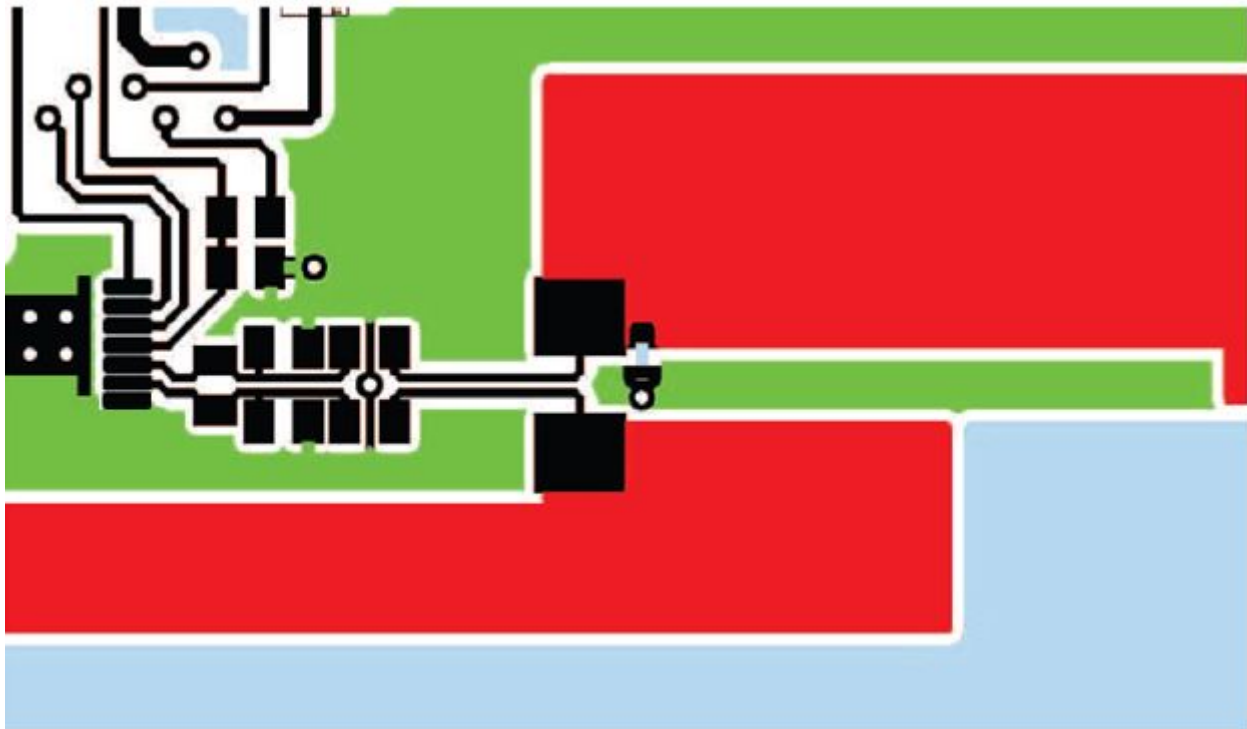

**Figure 19. High-Current Versus Low-Current Ground Layout**

### 10.2.2 Kelvin Connections

Kelvin voltage sensing is very important to accurately measure current and cell voltage. Note that in [Figure 19](#) the differential connections at the sense resistor do not add any voltage drop across the copper etch that carries the high current path through the sense resistor.

### 10.2.3 Board Offset Considerations

Although the most important component for board offset reduction is the decoupling capacitor for REGIN, additional benefit is possible by using this recommended pattern for the coulomb counter differential low-pass filter network.

Maintain the symmetrical placement pattern shown for optimum current offset performance. Use symmetrical shielded differential traces, if possible, from the sense resistor to the 100- $\Omega$  resistors, as shown in [Figure 20](#).

Layout Example (continued)

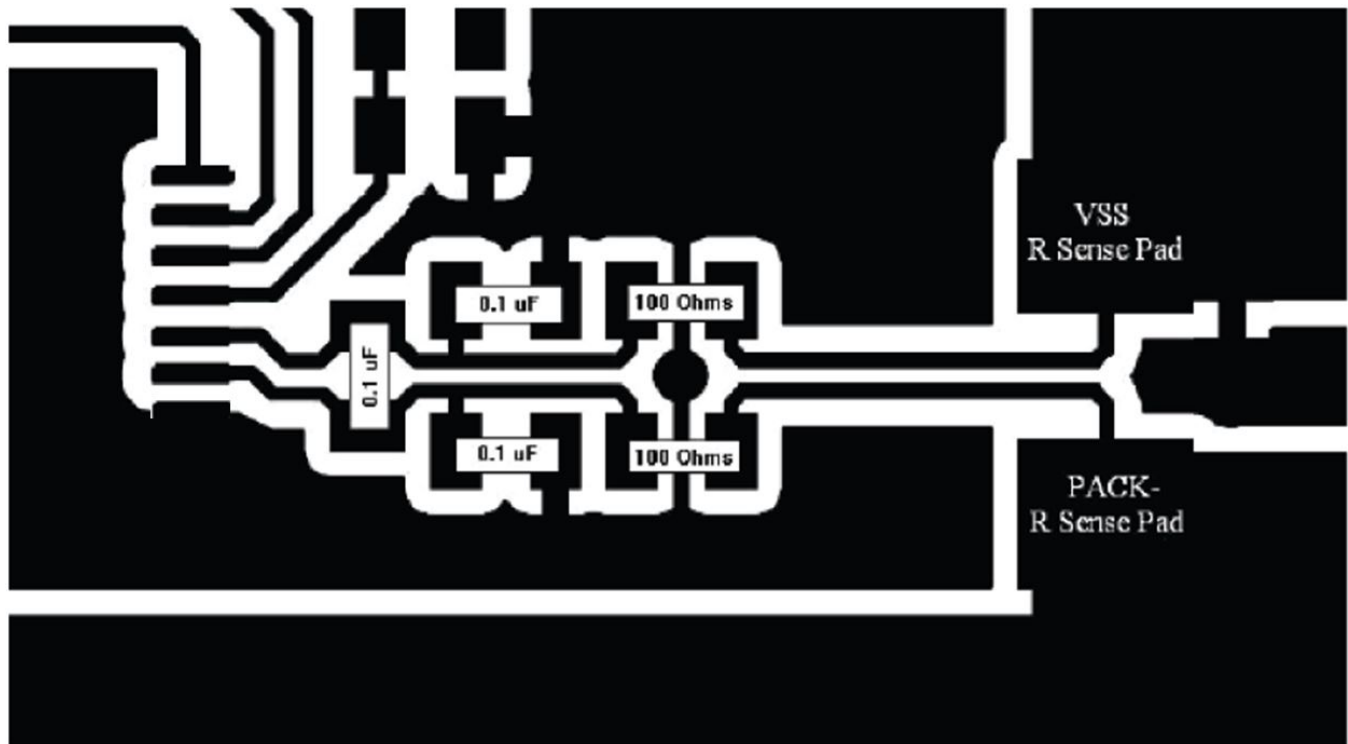

Figure 20. Differential Connection Between SRP and SRN Pins with Sense Resistor

10.2.4 ESD Spark Gap

Protect the communication lines from ESD with a spark gap at the connector. Figure 21 shows the recommended pattern with its 0.2-mm spacing between the points.

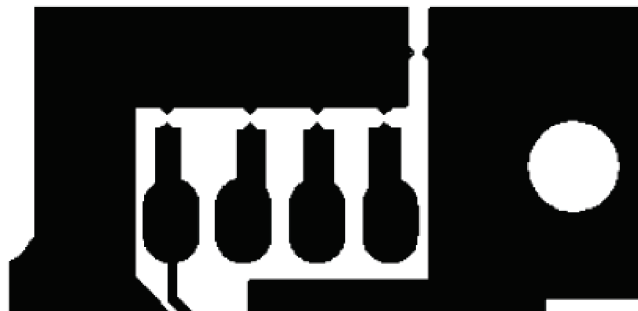

Figure 21. Recommended Spark-Gap Pattern Helps Protect Communication Lines from ESD

## 11 Device and Documentation Support

### 11.1 Documentation Support

#### 11.1.1 Related Documentation

- *bq34110 Technical Reference Manual* ([SLUUBF7](#))
- *bq34110 EVM User's Guide* ([SLUUB11](#))
- *Using I<sup>2</sup>C Communication with the bq275xx Series of Fuel Gauges Application Report* ([SLUA467](#))

### 11.2 Receiving Notification of Documentation Updates

To receive notification of documentation updates, navigate to the device product folder on ti.com. In the upper right corner, click on *Alert me* to register and receive a weekly digest of any product information that has changed. For change details, review the revision history included in any revised document.

### 11.3 Community Resources

The following links connect to TI community resources. Linked contents are provided "AS IS" by the respective contributors. They do not constitute TI specifications and do not necessarily reflect TI's views; see TI's [Terms of Use](#).

**TI E2E™ Online Community** *TI's Engineer-to-Engineer (E2E) Community*. Created to foster collaboration among engineers. At e2e.ti.com, you can ask questions, share knowledge, explore ideas and help solve problems with fellow engineers.

**Design Support** *TI's Design Support* Quickly find helpful E2E forums along with design support tools and contact information for technical support.

### 11.4 Trademarks

E2E is a trademark of Texas Instruments.

I<sup>2</sup>C is a trademark of NXP B.V. Corporation.

All other trademarks are the property of their respective owners.

### 11.5 Electrostatic Discharge Caution



These devices have limited built-in ESD protection. The leads should be shorted together or the device placed in conductive foam during storage or handling to prevent electrostatic damage to the MOS gates.

### 11.6 Glossary

[SLYZ022](#) — *TI Glossary*.

This glossary lists and explains terms, acronyms, and definitions.

## 12 Mechanical, Packaging, and Orderable Information

The following pages include mechanical, packaging, and orderable information. This information is the most current data available for the designated devices. This data is subject to change without notice and revision of this document. For browser-based versions of this data sheet, refer to the left-hand navigation.

**PACKAGING INFORMATION**

Orderable Device	Status (1)	Package Type	Package Drawing	Pins	Package Qty	Eco Plan (2)	Lead/Ball Finish (6)	MSL Peak Temp (3)	Op Temp (°C)	Device Marking (4/5)	Samples
BQ34110PW	ACTIVE	TSSOP	PW	14	90	Green (RoHS & no Sb/Br)	NIPDAU	Level-2-260C-1 YEAR	-40 to 85	BQ34110	<a href="#">Samples</a>
BQ34110PWR	ACTIVE	TSSOP	PW	14	2000	Green (RoHS & no Sb/Br)	NIPDAU	Level-2-260C-1 YEAR	-40 to 85	BQ34110	<a href="#">Samples</a>

(1) The marketing status values are defined as follows:

**ACTIVE:** Product device recommended for new designs.

**LIFEBUY:** TI has announced that the device will be discontinued, and a lifetime-buy period is in effect.

**NRND:** Not recommended for new designs. Device is in production to support existing customers, but TI does not recommend using this part in a new design.

**PREVIEW:** Device has been announced but is not in production. Samples may or may not be available.

**OBsolete:** TI has discontinued the production of the device.

(2) **RoHS:** TI defines "RoHS" to mean semiconductor products that are compliant with the current EU RoHS requirements for all 10 RoHS substances, including the requirement that RoHS substance do not exceed 0.1% by weight in homogeneous materials. Where designed to be soldered at high temperatures, "RoHS" products are suitable for use in specified lead-free processes. TI may reference these types of products as "Pb-Free".

**RoHS Exempt:** TI defines "RoHS Exempt" to mean products that contain lead but are compliant with EU RoHS pursuant to a specific EU RoHS exemption.

**Green:** TI defines "Green" to mean the content of Chlorine (Cl) and Bromine (Br) based flame retardants meet JS709B low halogen requirements of <=1000ppm threshold. Antimony trioxide based flame retardants must also meet the <=1000ppm threshold requirement.

(3) MSL, Peak Temp. - The Moisture Sensitivity Level rating according to the JEDEC industry standard classifications, and peak solder temperature.

(4) There may be additional marking, which relates to the logo, the lot trace code information, or the environmental category on the device.

(5) Multiple Device Markings will be inside parentheses. Only one Device Marking contained in parentheses and separated by a "-" will appear on a device. If a line is indented then it is a continuation of the previous line and the two combined represent the entire Device Marking for that device.

(6) Lead/Ball Finish - Orderable Devices may have multiple material finish options. Finish options are separated by a vertical ruled line. Lead/Ball Finish values may wrap to two lines if the finish value exceeds the maximum column width.

**Important Information and Disclaimer:**The information provided on this page represents TI's knowledge and belief as of the date that it is provided. TI bases its knowledge and belief on information provided by third parties, and makes no representation or warranty as to the accuracy of such information. Efforts are underway to better integrate information from third parties. TI has taken and continues to take reasonable steps to provide representative and accurate information but may not have conducted destructive testing or chemical analysis on incoming materials and chemicals. TI and TI suppliers consider certain information to be proprietary, and thus CAS numbers and other limited information may not be available for release.

In no event shall TI's liability arising out of such information exceed the total purchase price of the TI part(s) at issue in this document sold by TI to Customer on an annual basis.



## TAPE AND REEL INFORMATION

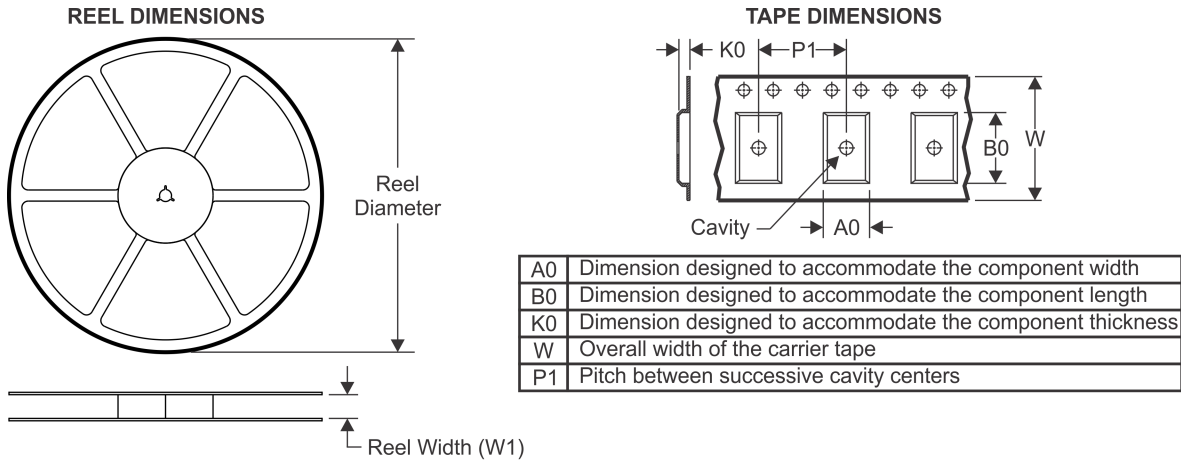

### QUADRANT ASSIGNMENTS FOR PIN 1 ORIENTATION IN TAPE



\*All dimensions are nominal

Device	Package Type	Package Drawing	Pins	SPQ	Reel Diameter (mm)	Reel Width W1 (mm)	A0 (mm)	B0 (mm)	K0 (mm)	P1 (mm)	W (mm)	Pin1 Quadrant
BQ34110PWR	TSSOP	PW	14	2000	330.0	12.4	6.9	5.6	1.6	8.0	12.0	Q1

**TAPE AND REEL BOX DIMENSIONS**



\*All dimensions are nominal

Device	Package Type	Package Drawing	Pins	SPQ	Length (mm)	Width (mm)	Height (mm)
BQ34110PWR	TSSOP	PW	14	2000	338.1	338.1	20.6



PW (R-PDSO-G14)

PLASTIC SMALL OUTLINE

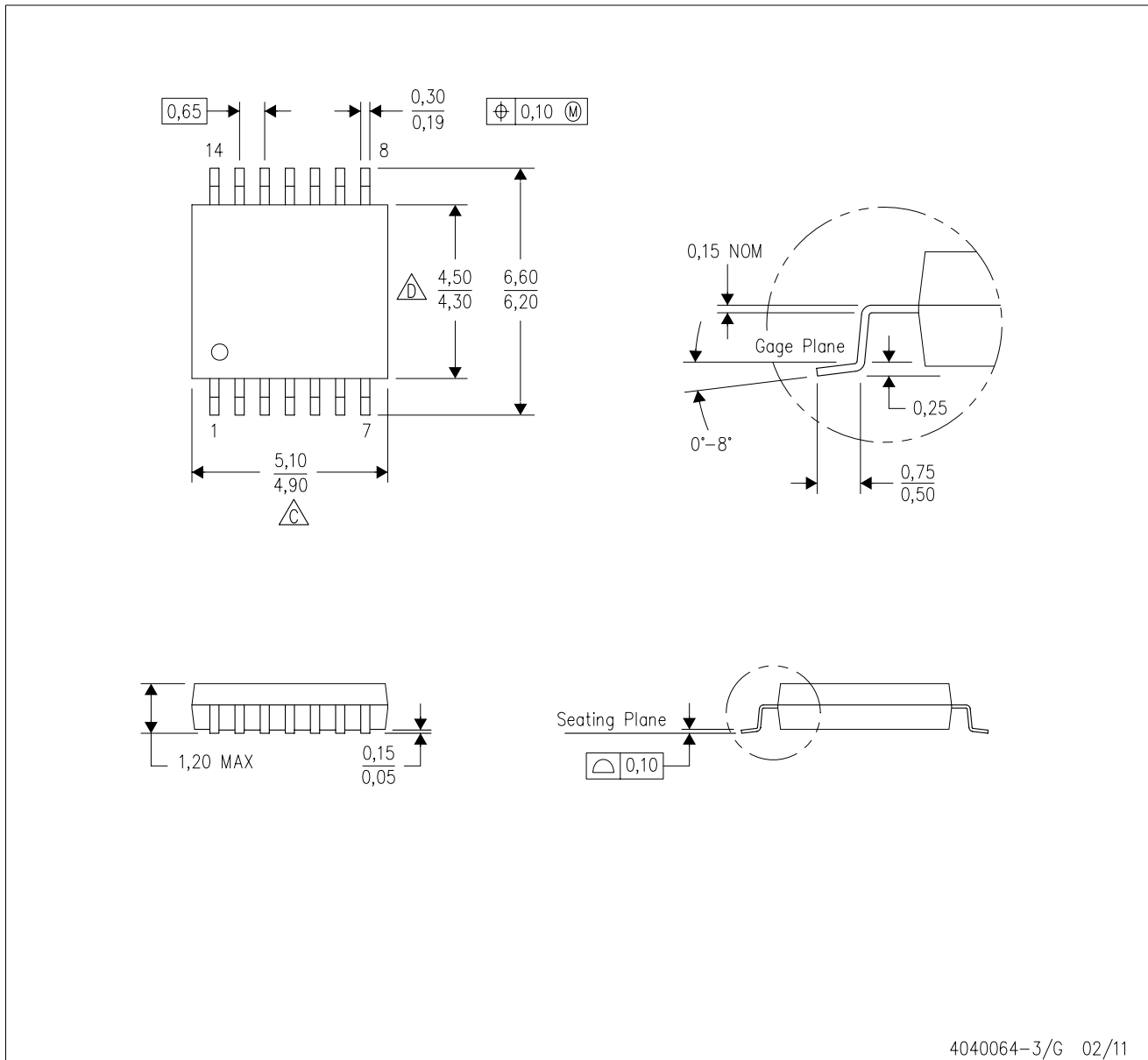

- NOTES:
- A. All linear dimensions are in millimeters. Dimensioning and tolerancing per ASME Y14.5M-1994.
  - B. This drawing is subject to change without notice.
  - C. Body length does not include mold flash, protrusions, or gate burrs. Mold flash, protrusions, or gate burrs shall not exceed 0,15 each side.
  - D. Body width does not include interlead flash. Interlead flash shall not exceed 0,25 each side.
  - E. Falls within JEDEC MO-153

PW (R-PDSO-G14)

PLASTIC SMALL OUTLINE



4211284-2/G 08/15

- NOTES:
- All linear dimensions are in millimeters.
  - This drawing is subject to change without notice.
  - Publication IPC-7351 is recommended for alternate designs.
  - Laser cutting apertures with trapezoidal walls and also rounding corners will offer better paste release. Customers should contact their board assembly site for stencil design recommendations. Refer to IPC-7525 for other stencil recommendations.
  - Customers should contact their board fabrication site for solder mask tolerances between and around signal pads.

## IMPORTANT NOTICE AND DISCLAIMER

TI PROVIDES TECHNICAL AND RELIABILITY DATA (INCLUDING DATASHEETS), DESIGN RESOURCES (INCLUDING REFERENCE DESIGNS), APPLICATION OR OTHER DESIGN ADVICE, WEB TOOLS, SAFETY INFORMATION, AND OTHER RESOURCES "AS IS" AND WITH ALL FAULTS, AND DISCLAIMS ALL WARRANTIES, EXPRESS AND IMPLIED, INCLUDING WITHOUT LIMITATION ANY IMPLIED WARRANTIES OF MERCHANTABILITY, FITNESS FOR A PARTICULAR PURPOSE OR NON-INFRINGEMENT OF THIRD PARTY INTELLECTUAL PROPERTY RIGHTS.

These resources are intended for skilled developers designing with TI products. You are solely responsible for (1) selecting the appropriate TI products for your application, (2) designing, validating and testing your application, and (3) ensuring your application meets applicable standards, and any other safety, security, or other requirements. These resources are subject to change without notice. TI grants you permission to use these resources only for development of an application that uses the TI products described in the resource. Other reproduction and display of these resources is prohibited. No license is granted to any other TI intellectual property right or to any third party intellectual property right. TI disclaims responsibility for, and you will fully indemnify TI and its representatives against, any claims, damages, costs, losses, and liabilities arising out of your use of these resources.

TI's products are provided subject to TI's Terms of Sale ([www.ti.com/legal/termsofsale.html](http://www.ti.com/legal/termsofsale.html)) or other applicable terms available either on [ti.com](http://ti.com) or provided in conjunction with such TI products. TI's provision of these resources does not expand or otherwise alter TI's applicable warranties or warranty disclaimers for TI products.

Mailing Address: Texas Instruments, Post Office Box 655303, Dallas, Texas 75265  
Copyright © 2020, Texas Instruments Incorporated