

NCN5192NGEVB

NCN5192NG Evaluation Board User's Manual



ON Semiconductor®

www.onsemi.com

EVAL BOARD USER'S MANUAL

Introduction

The NCN5192NGEVB includes all external components needed for operating NCN5192 and demonstrates the small PCB surface area such an implementation requires. The EVB allows easy design of HART implementations using NCN5192.

Overview

The NCN5192 is a single-chip, CMOS modem for use in highway addressable remote transducer (HART) field instruments and masters. The modem and a few external passive components provide all of the functions needed to satisfy HART physical layer requirements including modulation, demodulation, receive filtering, carrier detect, and transmit-signal shaping.

The NCN5192 also includes an internal 16-bit sigma-delta modulation DAC for easy implementation of slave devices. An SPI bus provides easy communication to this DAC and internal registers.

Features

- Single-chip, Half-duplex 1200 bits per Second FSK Modem
- Bell 202 Shift Frequencies of 1200 Hz and 2200 Hz
- 3.0 V – 5.5 V Power Supply
- Transmit-signal Wave Shaping
- Receive Band-pass Filter
- Low Power: Optimal for Intrinsically Safe Applications
- Compatible with 3.3 V or 5 V Microcontroller
- Internal Oscillator with 1.84 MHz Crystal
- Meets HART Physical Layer Requirements
- Includes 16-bit DAC for Slave Implementation
- Industrial Temperature Range of -40°C to $+85^{\circ}\text{C}$
- Available in 32-pin QFN

Applications

- HART Multiplexers
- HART Modem Interfaces
- 4-20 mA Loop Powered Transmitters

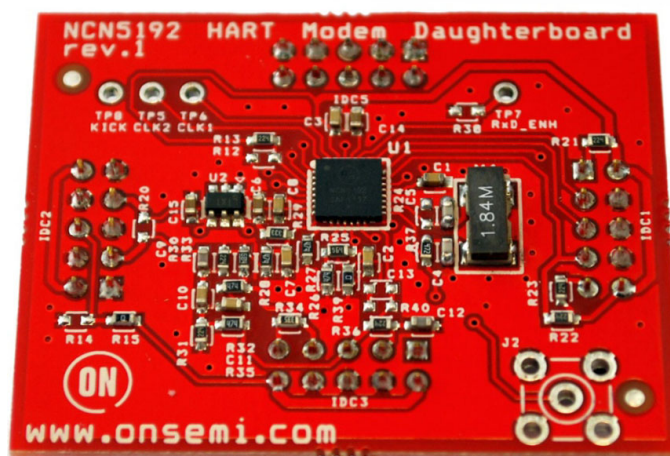

Figure 1. NCN5192NGEVB Evaluation Board

NCN5192NGEVB

Table 1. ELECTRICAL CHARACTERISTICS OF THE NCN5192NGEVB BOARD

Symbol	Characteristic	Min	Typ	Max	Units
V _{DD}	Supply Voltage	2.80	3.00	6.00	V
Current Consumption					
I _{DD}	V _{DD} = 2.80 V, idle	–	350	–	μA
I _{DD}	V _{DD} = 3.00 V, idle	–	360	–	μA
I _{DD}	V _{DD} = 6.00 V, idle	–	490	–	μA
I _{DD}	External Clock, V _{DD} = 3.00 V, idle	–	290	–	μA
I _{DD}	External Clock, V _{DD} = 2.80 V, idle	–	240	–	μA
Transmitted Frequency					
f _M	Mark “1”	–	1194	–	Hz
f _S	Space “0”	–	2204	–	Hz
Levels					
V _{TxA}	Amplitude Transmit Output	–	500	–	mV p-p
V _{CD}	Carrier Detect Level	–	110	–	mV p-p
Reference Voltages					
V _{AREF}	AREF	–	1.248	–	V
V _{CDREF}	CDREF	–	1.163	–	V

NCN5192 Description

The NCN5192 modem is a single-chip CMOS modem for use in HART field instruments and masters. It includes on-chip oscillator and a modulator and demodulator module communicating with a UART without internal buffer, as well as an internal 16 bit sigma delta DAC. The NCN5192 requires some external filter components and a 460.8 kHz, 921.6 kHz, or 1.84 MHz clock source. This clock source can either be the interface oscillator by using a crystal or ceramic resonator, or an external clock signal.

When the device is transmitting data, the receive module is shut down and vice versa to conserve power. With simple power-saving maneuvers, the IC can be made to operate with a current consumption of as little as 250 μA. The same techniques apply as explained for the A5191HRT in the Design Note “A5191HRT Design for Low-Power Environments” (AND9030/D).

Test and Measurement Tools

Listed below are the tools used to acquire the values presented in this evaluation board.

- Oscilloscope: Tektronix DPO4101 1 GHz
- Signal Generator: Agilent 33250A

NCN5192NGEVB

NCN5192NGEVB DESCRIPTION

Schematic Diagram – BOM List

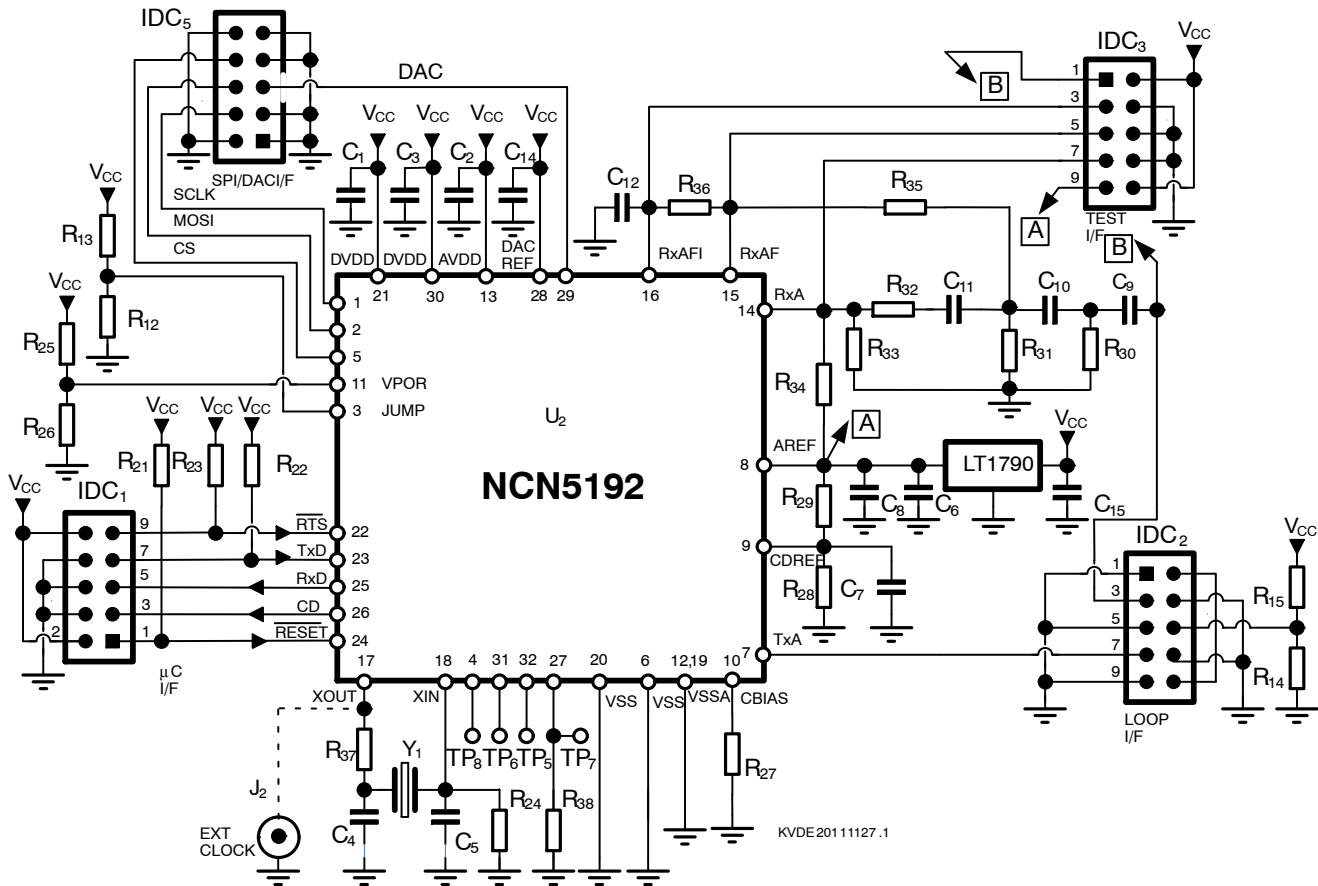

Figure 2. NCN5192NGEVB Schematic

NCN5192NGEVB

Table 2. NCN5192NGEVB BILL OF MATERIALS

Reference	Manufacturer & Comments	Value	Size	Quantity
C ₁ , C ₂ , C ₃ , C ₇ , C ₈		100 nF	0603	5
C ₄ , C ₅		27 pF	0603	2
C ₆ , C ₁₄ , C ₁₅		1 μF	0603	3
C ₉		470 nF	0603	1
C ₁₀ , C ₁₁		1 nF	0603	2
C ₁₂		220 pF	0603	1
C ₁₃	Do Not Populate	DNP	0603	1
IDC ₁ , IDC ₂ , IDC ₃ , IDC ₄		IDC10		4
J ₂	SMB Connector, Do Not Populate	DNP	0603	1
R ₁₂ , R ₁₄ , R ₂₀ , R ₂₄ , R ₃₈ , R ₄₀	Do Not Populate	DNP	0603	6
R ₁₃ , R ₂₁ , R ₂₂ , R ₂₃ , R ₃₀ , R ₃₁ , R ₃₆		220 kΩ	0603	7
R ₁₅ , R ₃₉		0 R	0603	2
R ₂₅		560 kΩ	0603	1
R ₂₆ , R ₂₇ , R ₂₈ , R ₃₂ , R ₃₅		470 kΩ	0603	5
R ₂₉		33 kΩ	0603	1
R ₃₃		680 kΩ	0603	1
R ₃₄		3M3	0603	1
R ₃₇		4k7	0603	1
TP ₅ , TP ₆ , TP ₇ , TP ₈	Do Not Populate	DNP		4
U ₁	ON Semiconductor	NCN5192		1
U ₂	Linear Technology	LT1790-1.25		1
Y ₁	TOKEN	ZTACC1.84MG		1

General Overview

The NCN5192NGEVB evaluation board demonstrates the external components required for the operation of the IC. We will cover the different sections below as well as possible

alternatives. A drawing of the board where the different sections are indicated is shown below.

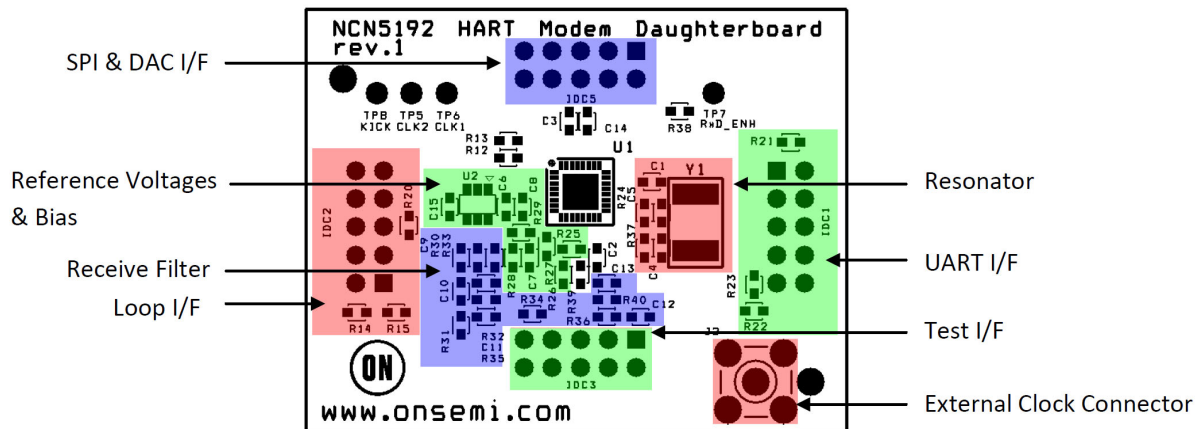

Figure 3. Board Drawing with Indication of Different Sections

Power Supply and References

Power Supply

The NCN5192NGEVB is designed for a nominal voltage of 3 V. However, NCN5192 can be operated up to 6 V. For optimal functioning of the board, the values of several resistors should be changed for operation at voltages higher than 3 V (see the sections on reference voltages and bias for more information).

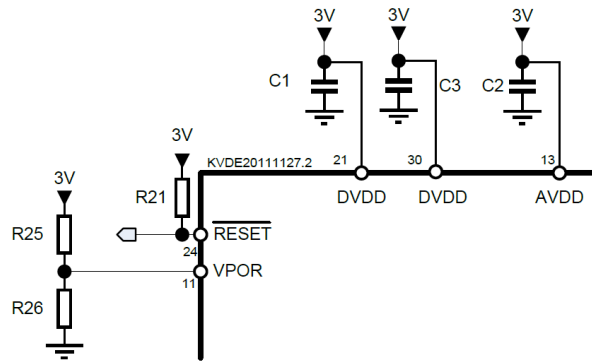

Figure 4. Supply Voltage and Power on Reset

Current consumption of the module is very limited, making it ideal to be battery or loop-powered. Measurements of the power consumption of the module are listed in Table 1.

The module will use less power when clock signal is applied externally, as this allows the modem to shut down the oscillator circuit. As is to be expected, a higher supply voltage increases current consumption.

The NCN5192 includes an internal voltage supervisor. This will guarantee correct operation of the digital circuitry during start-up. All that is required for using this supervisor is an external resistor divider (R25, R26). The voltage supervisor compares the voltage offered by the resistor divider on the VPOR pin to AREF. The resistor divider should be dimensioned such that at the desired turn-on point of the voltage supervisor, the VPOR pin is equal to AREF. On the evaluation board the resistor divider is dimensioned to make the POR trip at 2.8 V.

The voltage supervisor will keep the RESETB pin low until its threshold value is reached, and will then wait an additional minimum of 35 ms until it releases the RESETB. This ensures that some time has passed after the supply voltage reaches the turn-on voltage.

The RESETB en V_{DD} pin signals during startup are shown in Figure 5. The measured start-up delay is 48 ms.

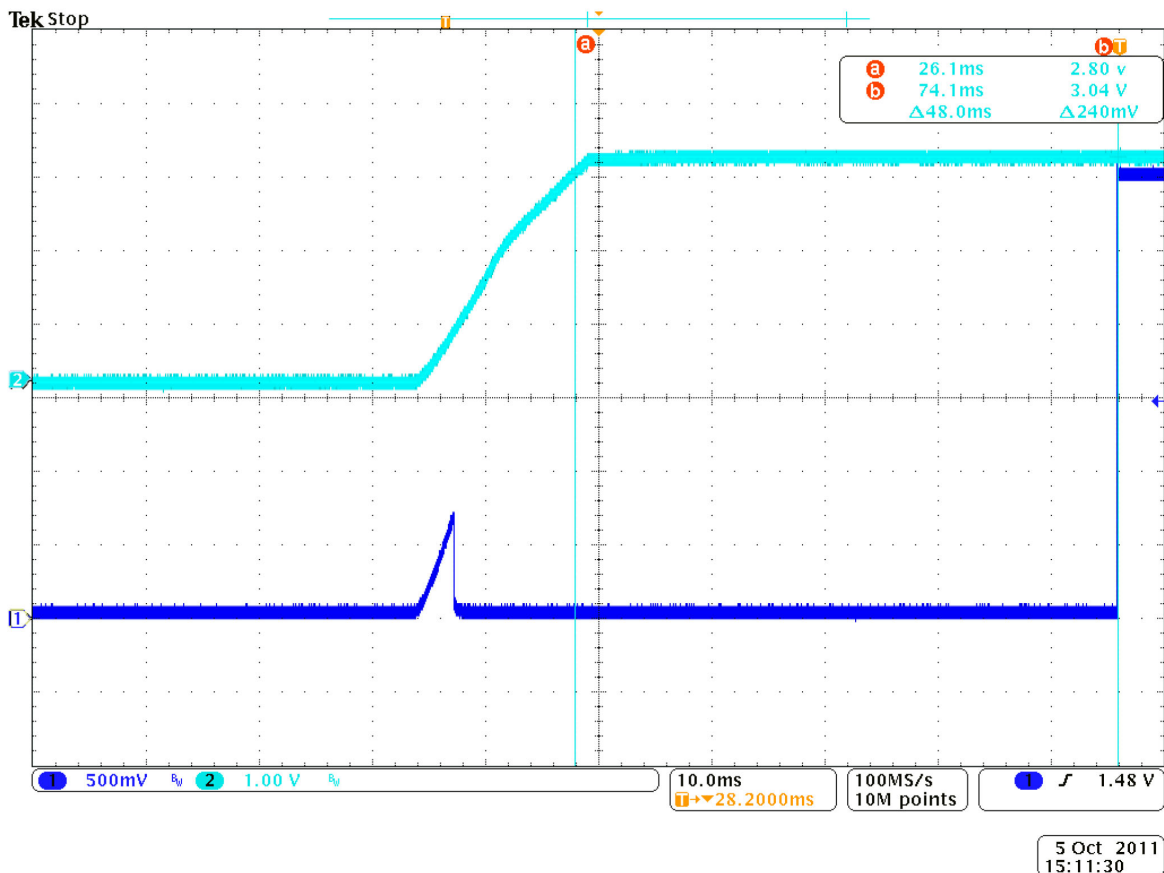

Figure 5. Power (Light Blue) and RESETB (Dark Blue) Waveform during Startup, Showing 48 ms Startup Delay

C₂, C₃ and C₁₄ are 100 nF ceramic decoupling capacitors located directly adjacent to each power pin. For analog power pins, an additional large-value ceramic capacitor may be needed in addition to the 100 nF decoupling capacitor when the application is intended for high-noise environments.

For loop-powered devices, additional decoupling with a large value capacitor is advised to prevent digital noise from being transmitted on the current loop.

Additional ferrite beads in series with power supply lines can help to reduce EMI.

Reference Voltages and Comparator Bias

NCN5192 needs an external analog reference voltage. This reference is used by receiver or demodulator (RX) comparator, carrier detect (CD), and voltage supervisor.

The AREF reference voltage sets the trip point of the demodulation operational amplifier of the NCP5192. The AREF reference voltage is also used in setting the DC operating point of the received signal after it has passed through the band-pass receive filter. The ideal value for the AREF reference voltage depends on the voltage supply, and is chosen roughly half-way the operating range of the operational amplifiers. This ensures the range of the operational amplifier is maximized. For operation at 3 V, a 1.24 V reference voltage is recommended. For operation at 5 V, a 2.5 V reference voltage is recommended.

For NCN5192NGEVB, a series regulator is used with an internal reference of 1.25 V. The chosen regulator has a very low supply current, to optimize power usage. Using a series

regulator is more desirable from a power usage perspective, as a series regulator’s current draw will vary with the output current, whereas a shunt regulator is dimensioned on the maximum current draw and will always draw the same current. Large capacitors on the in- and output of the voltage regulator increase the reference stability.

The CDREF reference voltage sets the threshold for the carrier detect comparator. As the received signal is biased at AREF, the difference between CDREF and AREF will determine the minimum amplitude needed for the carrier detect comparator to flip. A (AREF-CDREF) of 80 mV corresponds to signal of approximately 100 mV peak-to-peak at the input of the receive filter. The CDREF reference voltage on the NCN5192NGEVB is generated by a resistor division of the AREF reference.

An external resistor is required to set the bias current. The voltage over the bias resistor is regulated to AREF, so that the resistor determines a bias current. This bias current controls the operating parameters of the internal operational amplifiers and comparators and should be set to approximately 2.5 μA. For low cost solutions, a 470 kΩ is acceptable with minimal effect on operation.

Table 3. REFERENCE VOLTAGES

Description	Value
AREF Reference Voltage	1.248 V
CDREF Reference Voltage	1.163 V

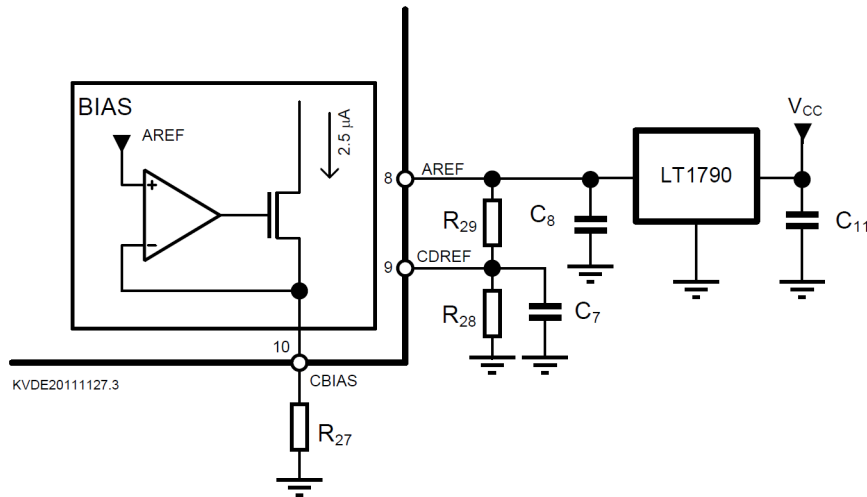

Figure 6. Reference Voltages Schematic

Clock Generation

NCN5192 is operated on a clock signal of either 460.8 kHz, 921.6 kHz or 1.84 MHz. The NCN5192NGEVB has two options for providing this clock signal. The first method is by using a ceramic resonator or a crystal with the internal oscillator. The standard populated option is a Token ZTACC1.84MG ceramic resonator, loaded with two 27 pF capacitors.

Alternatively, a clock signal can be provided externally when R₃₇ is removed and R₂₄ is populated by a resistor of 0 Ω. This signal can be provided by a microcontroller or any other external oscillator circuit. The module uses less power when clock signal is applied externally, as this allows the

modem to shut down the oscillator circuit. A typical current consumption witnessed by utilizing an external oscillator is 70-100 μA less. However, care must be taken that this external signal has the required frequency accuracy (1%).

Duty cycle of the clock signal is specified between 40% and 60%. No errors were observed during testing in operation between 20% and 80% duty cycle. However, operation on such very small or very large duty cycle is not recommended, due to the possibility of timing errors that may occur under specific circumstances (including, but not limited to, temperature variations).

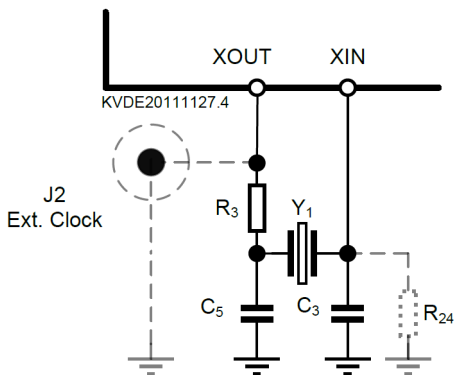

Figure 7. Clock Generation Circuit (Resonator Option)

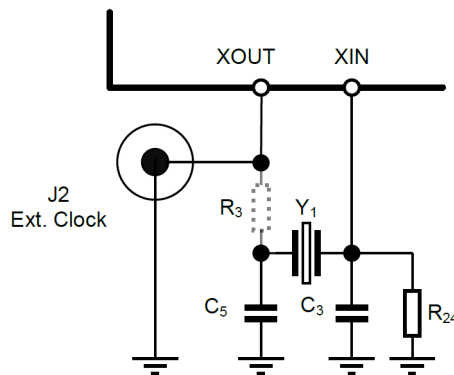

Figure 8. Clock Generation Circuit (External Clock)

UART Interface IDC₁

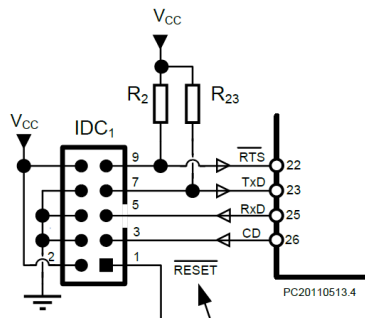

Figure 9. UART Interface (IDC₁)

Table 4. MICROCONTROLLER INTERFACE

Pin Number	Signal	Type	Description
1	RESETB	Open Drain	Reset Signal from the Voltage Supervisor, Open Drain with Pull-up, Active Low
3	CD	Output	Carrier Detect
5	RxD	Input	Receive from Microcontroller
7	TxD	Output	Transmit towards Microcontroller
9	RTSB	Input	Request to Send, Active Low
2, 10	VDD	Power	3 V Nominal
4, 6, 8	GND	Power	Ground

The interface towards a microcontroller is provided in IDC₁. This interface can also be used to supply power to the module. The nominal supply voltage for the module is 3 V. For more information see the section on power supply and references.

The RESETB line to the modem is an open drain signal. A pull-up resistor of 200 kΩ is provided on the board, and should not be duplicated on the microcontroller side. The reset signal is generated on the board, and could be used as reset signal for other IC such as the microcontroller.

The CD signal rises when a HART signal of ca. 100 mVpp is detected on the current loop. See the section on reference voltages for more information on these threshold level settings. When no signal, or a signal of limited amplitude is present, the CD line is pulled down to 0 V.

The RxD, TxD, and RTSB signals implement a standard UART interface at 1200 baud with start bit, 8 data bits, parity bit and stop bit (11-bit frame). The RTSB signal disconnects the transmitter circuit when pulled high, and should be held low before any data is transmitted. Data frames are not buffered by the modem. Instead, data is transmitted bit by bit. Care should be taken to avoid clock skew in the receiving UART. If the same time base is used for both the modem and the UART, a 1% accurate time base may not be sufficient. The problem is a combination of receive data jitter and clock skew between transmitting and receiving HART devices. If the transmit time base is at 99% of nominal and the receive

time base in another device is at 101% of nominal, the receive data (at the receiving UART) will be skewed by roughly 21% of one bit time at the end of each 11-bit byte. This is shown in Figure 10. The skew time is measured from the initial falling edge of the start bit to the center of the 11th bit cell. This 21% skew by itself is a relatively good result. However, there is another error source for bit boundary jitter. The Phase Lock Loop demodulator in the NCN5192 produces jitter in the receive data that can be as large as 12% of a bit time. Therefore, a bit boundary can be shifted by as much as 24% of a bit time relative to its ideal location based on the start-bit transition. (The start-bit transition and a later transition can be shifted in opposite directions for a total of 24%).

The clock skew and jitter added together is 45%, which is the amount that a bit boundary could be shifted from its expected position. UARTs that sample at mid-bit will not be affected. However, there are UARTs that take multiple samples during each bit to try to improve on error performance. These UARTs may not be satisfactory, depending on how close the samples are to each other, and how samples are interpreted. A UART that takes a majority vote of 3 samples is acceptable.

Even if your own time base is perfect, you still must plan on a possible 35% shift in a bit boundary, since you don't have control over time bases in other HART devices.

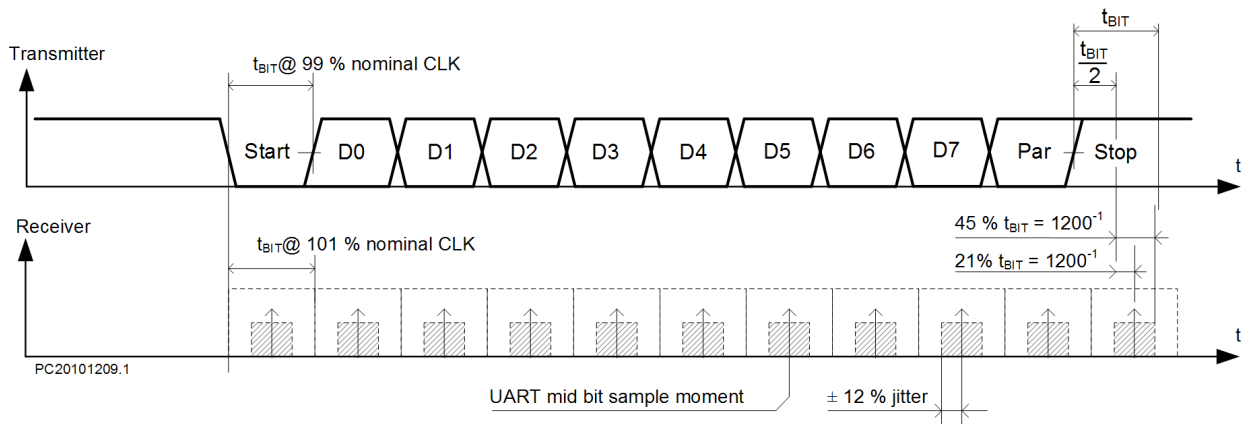

Figure 10. Clock Skew

SPI Interface and Internal Register

The NCN5192 also has an SPI interface that is used to control the integrated DAC and set the configuration register of the IC. This interface is accessible on the evaluation board through connector IDC₅.

The length of the SPI frame determines what the function of the frame is. For setting the internal register, the SPI frame has a length of 8 bits, containing all the bits of the internal register. To set the output of the integrated DAC, a frame of length 14 or 16 can be used, depending on which mode of the DAC is used. For more information, see the section on the integrated DAC.

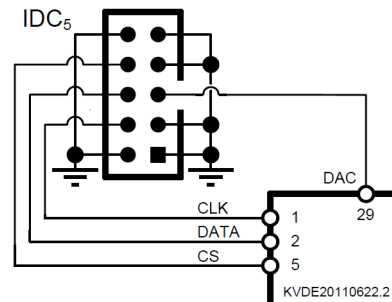

Figure 11. SPI Interface (IDC₅)

Table 5. SPI/DAC INTERFACE

Pin Number	Signal	Type	Description
5	DAC	Output	DAC Output
4	CLK	Input	SPI Clock
6	DATA	Input	SPI Data in (MOSI)
8	CS	Input	SPI Chip Select
1, 2, 3, 7, 9, 10	GND	Power	

At reset of the device, all bits of the internal register are set to 0. This means that, before being able to use the evaluation board, an SPI frame must first be sent to configure the device. This frame must set bit 1 and bit 5 to one, setting respectively the correct frequency division factor for the

wave shaping and activating the internal watchdog kick. Depending on your application, other bits may need to be set as well. See the description of the internal register in de The NCP5192 datasheet for more information.

Internal Sigma-Delta DAC

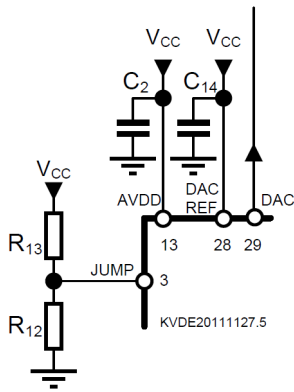

Figure 12. DAC Interface

The NCN5192 includes an internal DAC that can be used for the implementation of a slave analog transmitter.

The included DAC has a Sigma-Delta topology. This means that the output of the DAC is constantly switching

between 0 V en DACREF (3 V on the evaluation board). To achieve optimum accuracy, it is required that DACREF is sufficiently decoupled from the power supply, such as by a large-value ceramic capacitor (1 μF typical).

The switching output signal will have the desired DC (low frequency) component, but also includes a lot of switching noise that needs to be filtered out before the signal is useful. Figure 13 shows a typical frequency spectrum of the output of the DAC. This means that an output low pass filter is required before the DAC output can be used. Since the sigma-delta modulator is designed for a bandwidth of 10 Hz, it is advised that the corner frequency of the output filter is placed on this frequency.

For more information on how to design this filter, see the section on slave implementation.

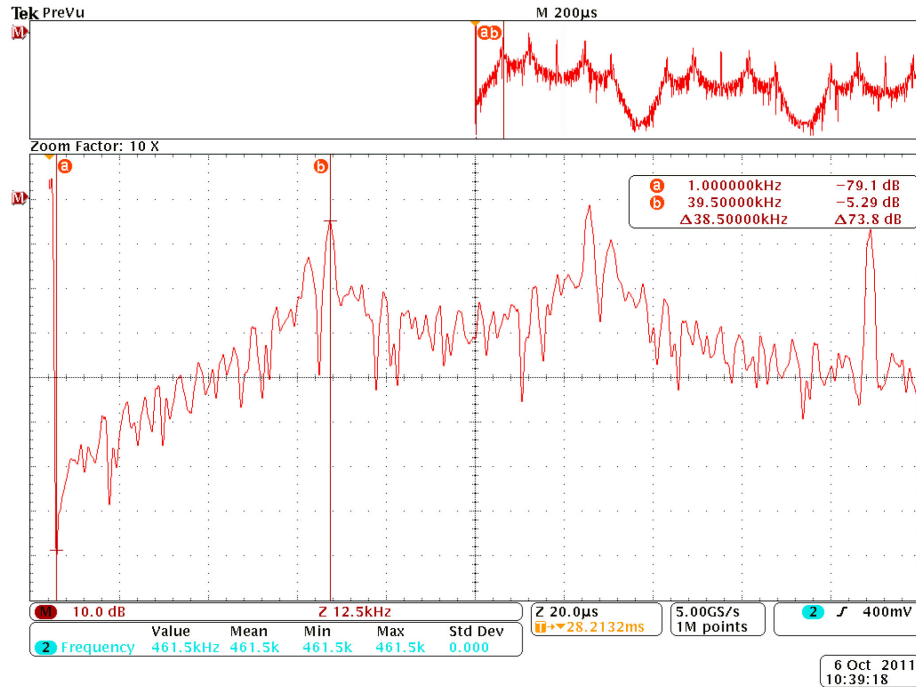

Figure 13. DAC Output Spectrum (code 32768, 16 bits non-RTZ)

By default the DAC is set to 14-bit, RTZ (return to zero) mode. The DAC can be set to either RTZ or non-RTZ mode. This is important when rise and fall times are not identical. This will cause a DC offset depending on the number of rising and falling edges. As the output bits of a sigma-delta modulator are randomly arranged, the number of edges might vary widely in non-RTZ mode, which results in reduced accuracy. Setting the DAC to RTZ mode forces the modulator to have a rising and falling edge on each logic “1” bit, so that no offset from pulse asymmetry can occur.

Transmitter

The TxA modem pin is accessible through pin 7 of IDC₂. For certain applications, it might be required to couple the transmit signal in the circuit by adding a series capacitor. Note that this is a difference with the A5191HRTNEVB, where this coupling capacitor was provided on the board. The output on this pin is a 500 mVpp signal trapezoid

However, operating the DAC in RTZ mode limits the operational range of the DAC to half of the voltage applied to the DACREF pin. By setting the DAC to non-RTZ (setting bit 6 of the internal register), a larger output range is achieved, but at the cost of accuracy. In non-RTZ mode, 16-bit accuracy will be harder to obtain.

To achieve maximum accuracy of the DAC, it is also advised to use a separate, low-noise reference as DACREF instead of tying this pin to V_{DD}, and to keep the DAC line away from noisy signal lines.

waveform shown in figures 12 and 13. This pin can only drive impedances higher than 30 kΩ, and as a consequence may need to be amplified.

The nominal frequency of the output is 1200 Hz for “mark” and 2200 Hz for “space”. These frequencies are dependent on the accuracy of the NCN5192 clock.

NCN5192NGEVB

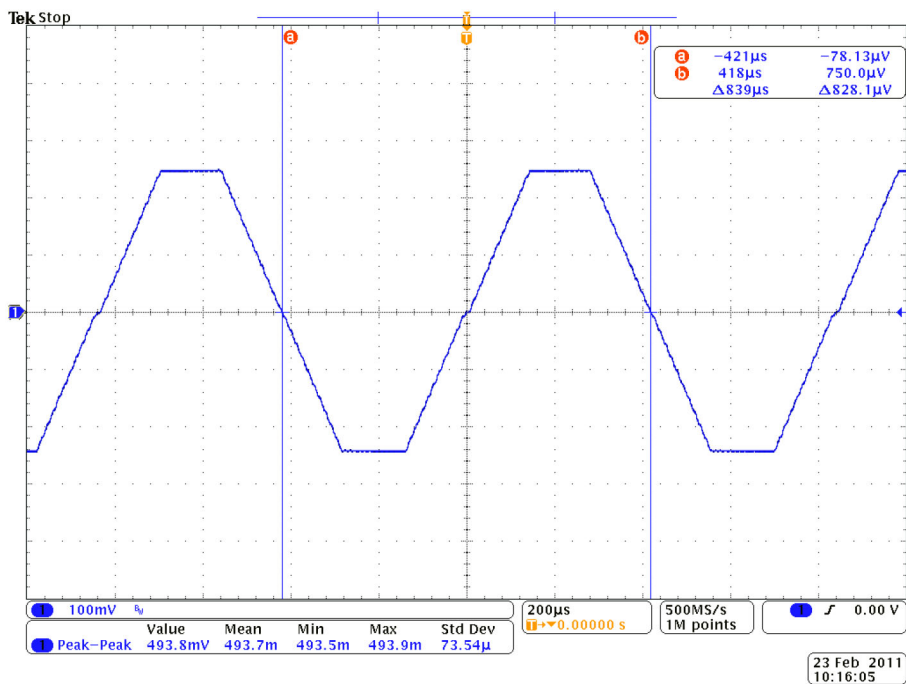

Figure 14. Output Waveform (Mark)

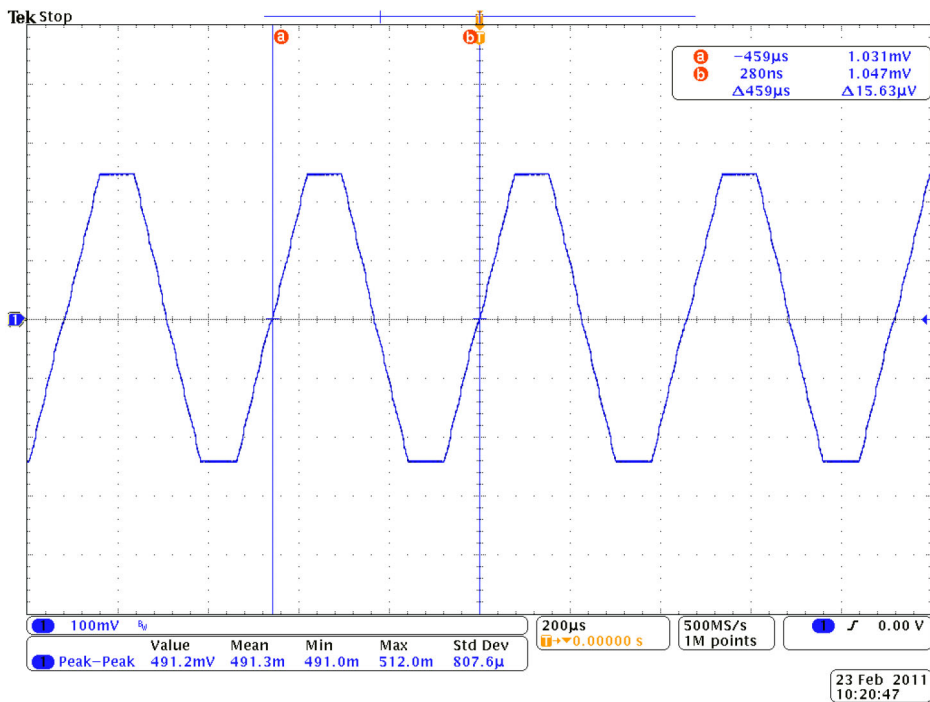

Figure 15. Output Waveform (Space)

Receiver

The receive band pass filter is implemented on the NCN5192NGEVB. The values are listed in Table 6 and the filter schematic is displayed in Figure 16. This is a band pass filter based on a Sallen-Key topology allowing only frequencies around the HART signal frequencies to pass

through. For a more detailed description of the filter see the user manual of A5191HRTNEVB.

APPLICATION IDEAS

The NCN5192 takes care of the HART modulation. This HART signal must then be superimposed on a 4-20 mA current loop. The NCN5192 simplifies slave implementation

Slave Implementation

A simple slave implementation is shown in Figure 18. The analog loop current is set by the integrated DAC, and HART signals are added to this by a resistive summing network. The DAC is implemented as a sigma-delta modulator, which means that additional filtering should be implemented. To explain the operation of this circuit, let us first look at an example where the DAC is not of a switching topology, such as shown in Figure 17. As one end of R_6 is tied to local ground, and current passing through R_7 also passes through

by including an integrated DAC. Below are some possible implementations of both a master and slave transmitter.

R_6 , it can easily be seen that the voltage at the negative loop terminal is negative with respect to the local ground. Resistor R_4 is then chosen so that in steady state their common terminal is a virtual ground point in the absence of HART signals, since the negative terminal of the amplifier is also connected to ground. A similar principle applies when HART signals are applied. So both amplifier inputs are regulated to ground.

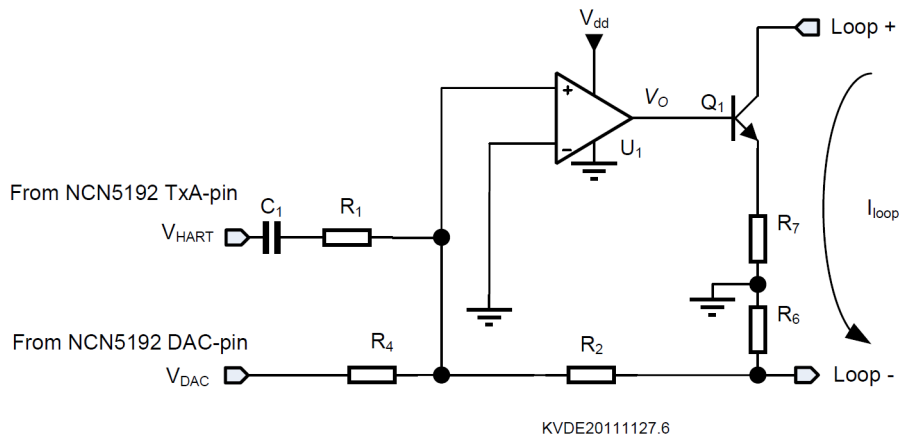

Figure 17. Simple Slave Implementation

A compensation capacitor C_4 may be required depending on the operational amplifier used. To avoid offset generated by bias current in the operational amplifier, a resistor R_3 should be placed on the negative input, and dimensioned to approach the impedance seen by the positive terminal.

The amplifier will then determine the current flowing through the loop by changing the base of a transistor in emitter feedback configuration. The value for R_7 is determined by the output range $V_{o,max}$ of the amplifier used:

$$R_{7,max} = \frac{V_{o,max} - V_{BE}}{20 \text{ mA}}$$

It is often recommended to take a value as large as possible, so that noise effects are minimal.

Typically the value of R_6 is chosen equal to R_7 . The voltage over R_6 and R_7 combined should however be less than 12 V when the current setting is 20 mA.

Next, the value of R_4 is chosen depending on the most significant bit of the DAC.

$$2 V_{MSB} R_2 = 20 \text{ mA } R_6 R_4$$

When the DAC is not a switching topology, we can now choose R_1 and C_1 . We have:

$$500 \text{ mV } R_2 = 1 \text{ mA } R_6 Z$$

Where:

$$Z = \left| \frac{1}{sC_1} + R_1 \right|$$

In practice, C_1 is chosen sufficiently large so that $Z \approx R_1$.

Because the integrated DAC has a sigma-delta output, a circuit using the NCP5192 gets a bit more complicated, as can be seen in Figure 18. We need to filter away high frequency DAC components, but leave HART signals intact. A simple RC-filter is not sufficient, since the output capacitor has low impedance for HART frequencies. We can do this by replacing the summing resistor R_4 by a T-filter. This filter has high output impedance due to the output resistor.

To dimension this filter without too much calculation, we can treat it as a RC-filter using its first branch. The 3-dB frequency should be placed just above the DAC bandwidth (10 Hz).

We get, with $R_4 \approx R_5$:

$$f_{3dB} = \frac{1}{2\pi C_3 R_4}$$

To dimension the summing resistor of the HART input, we can no longer assume that the positive input of the amplifier

is a virtual ground, as this assumption is only valid for DC signals. We can, however, find a relationship between input amplitude and output amplitude. We know that the positive amplifier input voltage has the following form, due to the summing network:

$$V_+ = (R_1 // R_2 // (R_4 + R_5)) \left(\frac{V_{in}}{R_1} - \frac{V_{out}}{R_2} \right)$$

The amplifier is configured as an integrator for low frequencies, but for high frequencies, the amplifier configuration has a gain of 1, and the transistor is configured as a voltage follower, so we can conclude that for AC frequencies $V_+ = V_{out}$. Taking this into account, we get the following equation:

$$V_{out} = \frac{R_2}{R_1} \frac{(R_1 // R_2 // (R_4 + R_5))}{(R_1 // R_2 // (R_4 + R_5)) + R_2} V_{in}$$

Reconfiguring for the unknown R_1 :

$$R_1 = \frac{R_2(R_4 + R_5)V_{in} + V_{out}(R_2 + R_3)}{V_{out}(1 + (R_4 + R_5))}$$

The amplifier is configured as an integrator for low frequencies. Care must be taken that the 3-dB frequency of the integrator is below the HART band, so that the amplifier gain in that band is independent of frequency. The resistor R_3 is chosen so that it compensates for input bias current. This is achieved by taking a value close to the resistance seen on the positive terminal. This means that the capacitor C_2 needs to be chosen so that $(2 \pi R_3 C_2)^{-1} < 1 \text{ kHz}$.

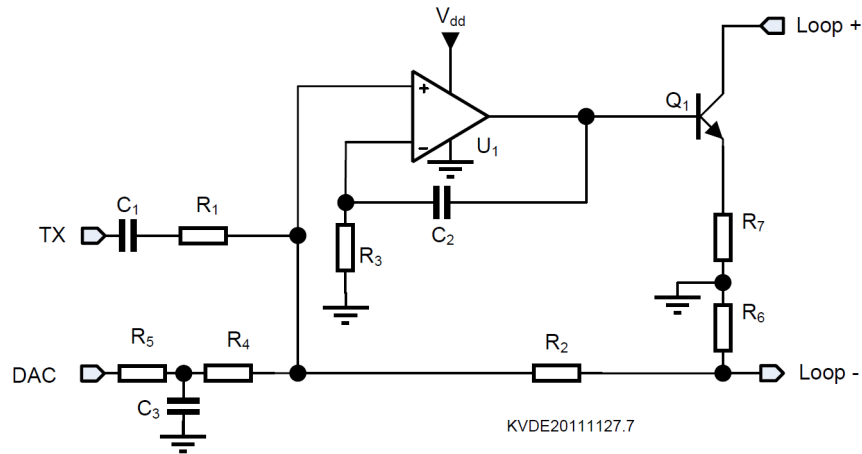

Figure 18. Sample Slave Implementation

Master Implementation

An example of a possible master implementation is shown in Figure 19.

The current loop master has a sense resistor over which the current flowing through the loop can be measured. The value of this resistor varies depending on the sensitivity required and range of the ADC. A HART Master can have a sense resistor ranging from 230 Ω to 600 Ω . Increasing the sense resistor will result in higher amplitude HART signal received, but will also reduce the voltage available on the slave side. Furthermore, if you wish to sense the analog transmitted signal, the MSB of your DAC may limit the resistor size. If this limitation is too stringent, the sense resistor can be split in two resistors, as shown in the figure, effectively creating a resistor divider.

To transmit a HART signal, the TxA signal will need to be amplified, as the NCN5192 transmit circuit can only drive high impedance circuits (>30 k Ω). An additional operational amplifier is required. Depending on the sense

resistor used, some gain or attenuation may be required to get a 1 mA peak-to-peak HART output signal. This can be accomplished by the resistors R_3 and R_4 . For a typical sense resistor of 500 Ω , a unity gain suffices and a unity gain operational amplifier configuration can be used instead.

The amplifier however has a low impedance output, which cannot be paralleled with the sense resistor, as this would cause problems when the slave is transmitting. This problem is solved by adding a series switch (such as MC74VHC1G66DTT1G), controlled by the RTS signal. For a normally open switch, the nRTS signal as applied to the NCN5192 must be inverted first. To reduce power usage, the operational amplifier can be disabled when the transmitter is turned off. This is both done by inserting PNP transistor Q_1 on the V_{DD} connection of the amplifier.

To couple the signal into the current loop, a single capacitor was used. For other coupling techniques see application note AND8346/D.

NCN5192NGEVB

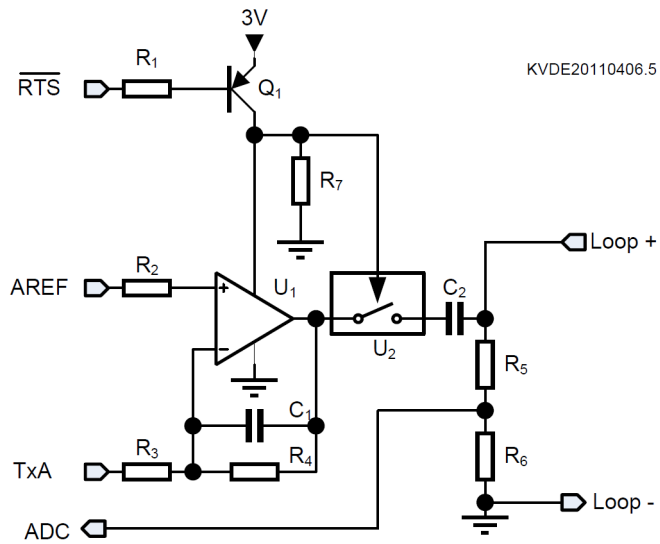

KVDE20110406.5

Figure 19. Sample Master Implementation

NCN5192NGEVB

APPENDIX

Evaluation Board Layout

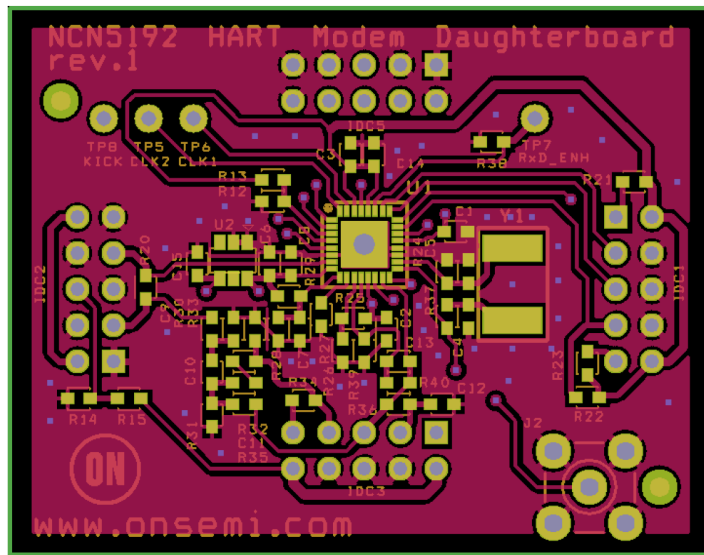

Figure 20. Top Layer Layout

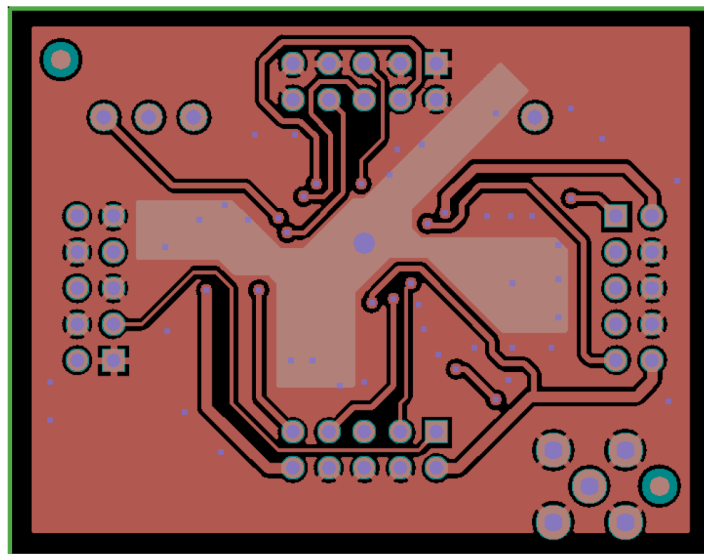

Figure 21. Bottom Layer Layout

ON Semiconductor and the ON Semiconductor logo are trademarks of Semiconductor Components Industries, LLC dba ON Semiconductor or its subsidiaries in the United States and/or other countries. ON Semiconductor owns the rights to a number of patents, trademarks, copyrights, trade secrets, and other intellectual property. A listing of ON Semiconductor's product/patent coverage may be accessed at www.onsemi.com/site/pdf/Patent-Marking.pdf. ON Semiconductor is an Equal Opportunity/Affirmative Action Employer. This literature is subject to all applicable copyright laws and is not for resale in any manner.

The evaluation board/kit (research and development board/kit) (hereinafter the "board") is not a finished product and is as such not available for sale to consumers. The board is only intended for research, development, demonstration and evaluation purposes and should as such only be used in laboratory/development areas by persons with an engineering/technical training and familiar with the risks associated with handling electrical/mechanical components, systems and subsystems. This person assumes full responsibility/liability for proper and safe handling. Any other use, resale or redistribution for any other purpose is strictly prohibited.

The board is delivered "AS IS" and without warranty of any kind including, but not limited to, that the board is production-worthy, that the functions contained in the board will meet your requirements, or that the operation of the board will be uninterrupted or error free. ON Semiconductor expressly disclaims all warranties, express, implied or otherwise, including without limitation, warranties of fitness for a particular purpose and non-infringement of intellectual property rights.

ON Semiconductor reserves the right to make changes without further notice to any board.

You are responsible for determining whether the board will be suitable for your intended use or application or will achieve your intended results. Prior to using or distributing any systems that have been evaluated, designed or tested using the board, you agree to test and validate your design to confirm the functionality for your application. Any technical, applications or design information or advice, quality characterization, reliability data or other services provided by ON Semiconductor shall not constitute any representation or warranty by ON Semiconductor, and no additional obligations or liabilities shall arise from ON Semiconductor having provided such information or services.

The boards are not designed, intended, or authorized for use in life support systems, or any FDA Class 3 medical devices or medical devices with a similar or equivalent classification in a foreign jurisdiction, or any devices intended for implantation in the human body. Should you purchase or use the board for any such unintended or unauthorized application, you shall indemnify and hold ON Semiconductor and its officers, employees, subsidiaries, affiliates, and distributors harmless against all claims, costs, damages, and expenses, and reasonable attorney fees arising out of, directly or indirectly, any claim of personal injury or death associated with such unintended or unauthorized use, even if such claim alleges that ON Semiconductor was negligent regarding the design or manufacture of the board.

This evaluation board/kit does not fall within the scope of the European Union directives regarding electromagnetic compatibility, restricted substances (RoHS), recycling (WEEE), FCC, CE or UL, and may not meet the technical requirements of these or other related directives.

FCC WARNING – This evaluation board/kit is intended for use for engineering development, demonstration, or evaluation purposes only and is not considered by ON Semiconductor to be a finished end product fit for general consumer use. It may generate, use, or radiate radio frequency energy and has not been tested for compliance with the limits of computing devices pursuant to part 15 of FCC rules, which are designed to provide reasonable protection against radio frequency interference. Operation of this equipment may cause interference with radio communications, in which case the user shall be responsible, at its expense, to take whatever measures may be required to correct this interference.

ON Semiconductor does not convey any license under its patent rights nor the rights of others.

LIMITATIONS OF LIABILITY: ON Semiconductor shall not be liable for any special, consequential, incidental, indirect or punitive damages, including, but not limited to the costs of requalification, delay, loss of profits or goodwill, arising out of or in connection with the board, even if ON Semiconductor is advised of the possibility of such damages. In no event shall ON Semiconductor's aggregate liability from any obligation arising out of or in connection with the board, under any theory of liability, exceed the purchase price paid for the board, if any.

For more information and documentation, please visit www.onsemi.com.

PUBLICATION ORDERING INFORMATION

LITERATURE FULFILLMENT:

Email Requests to: orderlit@onsemi.com

ON Semiconductor Website: www.onsemi.com

TECHNICAL SUPPORT

North American Technical Support:

Voice Mail: 1 800-282-9855 Toll Free USA/Canada

Phone: 011 421 33 790 2910

Europe, Middle East and Africa Technical Support:

Phone: 00421 33 790 2910

For additional information, please contact your local Sales Representative