

MAX222

5-V DUAL RS-232 LINE DRIVER/RECEIVER WITH ± 15 -kV ESD PROTECTION

SLLS590D – SEPTEMBER 2003 – REVISED AUGUST 2004

- ESD Protection for RS-232 Bus Pins
 - ± 15 -kV Human-Body Model
- Meets or Exceeds the Requirements of TIA/EIA-232-F and ITU v.28 Standards
- Operates at 5-V V_{CC} Supply
- Operates Up To 200 kbit/s
- Low Supply Current in Shutdown Mode . . . 2 μ A Typical
- External Capacitors . . . $4 \times 0.1 \mu$ F
- Latch-Up Performance Exceeds 100 mA Per JESD 78, Class II
- Applications
 - Battery-Powered Systems, PDAs, Notebooks, Laptops, Palmtop PCs, and Hand-Held Equipment

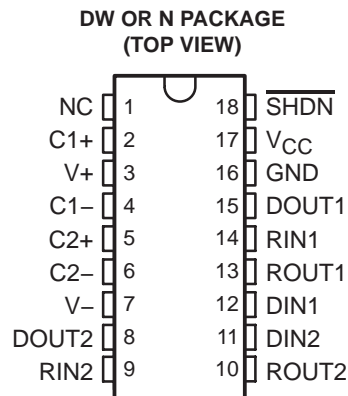

description/ordering information

The MAX222 consists of two line drivers, two line receivers, and a dual charge-pump circuit with ± 15 -kV ESD protection pin to pin (serial-port connection pins, including GND). This device meets the requirements of TIA/EIA-232-F and provides the electrical interface between an asynchronous communication controller and the serial-port connector. The charge pump and four small external capacitors allow operation from a single 5-V supply. This device operates at data signaling rates up to 200 kbit/s and a maximum of 30-V/ μ s driver output slew rate. By using $\overline{\text{SHDN}}$, all receivers can be disabled.

ORDERING INFORMATION

T_A	PACKAGE†	ORDERABLE PART NUMBER	TOP-SIDE MARKING
0°C to 70°C	PDIP (N)	Tube of 20	MAX222CN
	SOIC (DW)	Tube of 20	MAX222CDW
		Reel of 1000	MAX222CDWR
–40°C to 85°C	PDIP (N)	Tube of 20	MAX222IN
	SOIC (DW)	Tube of 20	MAX222IDW
		Reel of 1000	MAX222IDWR

† Package drawings, standard packing quantities, thermal data, symbolization, and PCB design guidelines are available at www.ti.com/sc/package.



Please be aware that an important notice concerning availability, standard warranty, and use in critical applications of Texas Instruments semiconductor products and disclaimers thereto appears at the end of this data sheet.

PRODUCTION DATA information is current as of publication date. Products conform to specifications per the terms of Texas Instruments standard warranty. Production processing does not necessarily include testing of all parameters.



POST OFFICE BOX 655303 • DALLAS, TEXAS 75265

Copyright © 2004, Texas Instruments Incorporated

MAX222
5-V DUAL RS-232 LINE DRIVER/RECEIVER
WITH ±15-kV ESD PROTECTION

SLLS590D – SEPTEMBER 2003 – REVISED AUGUST 2004

Function Tables

EACH DRIVER

INPUT D _{IN}	OUTPUT D _{OUT}
L	H
H	L

H = high level, L = low level

EACH RECEIVER

INPUT R _{IN}	OUTPUT R _{OUT}
L	H
H	L
Open	H

H = high level, L = low level, Open = input disconnected or connected driver off

logic diagram (positive logic)

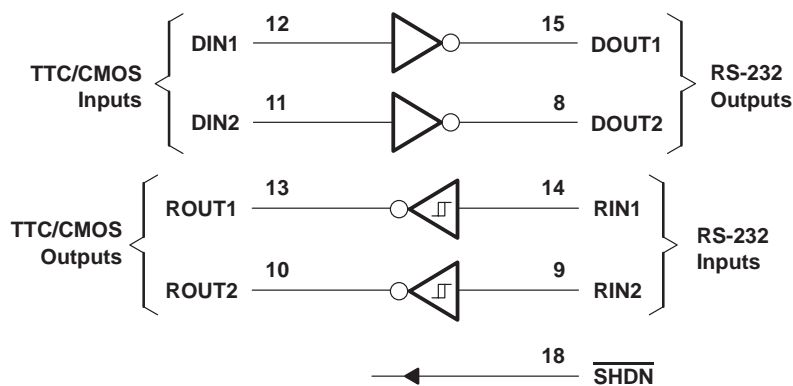

MAX222

5-V DUAL RS-232 LINE DRIVER/RECEIVER WITH ± 15 -kV ESD PROTECTION

SLLS590D – SEPTEMBER 2003 – REVISED AUGUST 2004

absolute maximum ratings over operating free-air temperature range (unless otherwise noted)†

Supply voltage range, V_{CC} (see Note 1)	–0.3 V to 6 V
Input voltage range, V_I : Drivers	–0.3 V to $V_{CC} - 0.3$ V
Receivers	± 30 V
Output voltage range, V_O : Drivers	± 15 V
Receivers	–0.3 V to $V_{CC} + 0.3$ V
Short-circuit duration, D_{OUT}	Continuous
Package thermal impedance, θ_{JA} (see Notes 2 and 3): DW package	TBD°C/W
N package	TBD°C/W
Operating virtual junction temperature, T_J	150°C
Storage temperature range, T_{stg}	–65°C to 150°C

† Stresses beyond those listed under “absolute maximum ratings” may cause permanent damage to the device. These are stress ratings only, and functional operation of the device at these or any other conditions beyond those indicated under “recommended operating conditions” is not implied. Exposure to absolute-maximum-rated conditions for extended periods may affect device reliability.

- NOTES:
1. All voltages are with respect to network GND.
 2. Maximum power dissipation is a function of $T_{J(max)}$, θ_{JA} , and T_A . The maximum allowable power dissipation at any allowable ambient temperature is $P_D = (T_{J(max)} - T_A)/\theta_{JA}$. Operating at the absolute maximum T_J of 150°C can affect reliability.
 3. The package thermal impedance is calculated in accordance with JESD 51-7.

recommended operating conditions (see Note 4 and Figure 4)

			MIN	NOM	MAX	UNIT
V_{CC}	Supply voltage		4.5	5	5.5	V
V_{IH}	Driver high-level input voltage	D_{IN}	2			V
	Shutdown high-level input voltage	\overline{SHDN}	2			V
V_{IL}	Driver low-level input voltage	D_{IN}			0.8	V
	Shutdown low-level input voltage	\overline{SHDN}			0.8	V
V_I	Driver input voltage	D_{IN}	0		5.5	V
	Receiver input voltage		–30		30	
T_A	Operating free-air temperature	MAX222C	0		70	°C
		MAX222I	–40		85	

NOTE 4: Test conditions are C1–C4 = 0.1 μ F at $V_{CC} = 5$ V \pm 0.5 V.

electrical characteristics over recommended ranges of supply voltage and operating free-air temperature (unless otherwise noted) (see Note 4 and Figure 4)

PARAMETER		TEST CONDITIONS		MIN	TYP	MAX	UNIT
I_{CC}	Supply current	$V_{CC} = 5$ V	$\overline{SHDN} = V_{CC}$	No load	4	10	mA
				3 k Ω on both inputs		15	
	Shutdown supply current				2	50	μ A
\overline{SHDN}	Shutdown input leakage current					± 1	μ A

NOTE 4: Test conditions are C1–C4 = 0.1 μ F at $V_{CC} = 5$ V \pm 0.5 V.



MAX222
5-V DUAL RS-232 LINE DRIVER/RECEIVER
WITH ±15-kV ESD PROTECTION

SLLS590D – SEPTEMBER 2003 – REVISED AUGUST 2004

DRIVER SECTION

electrical characteristics over recommended ranges of supply voltage and operating free-air temperature (unless otherwise noted) (see Note 4 and Figure 4)

PARAMETER		TEST CONDITIONS	MIN	TYP†	MAX	UNIT
V _{OH}	High-level output voltage	D _O UT at R _L = 3 kΩ to GND, D _I N = GND	5	8		V
V _{OL}	Low-level output voltage	D _O UT at R _L = 3 kΩ to GND, D _I N = V _{CC}	-5	-8		V
I _{IH}	Driver high-level input current	D _I N = V _{CC}		5	40	μA
	Control high-level input current	$\overline{\text{SHDN}} = V_{CC}$		0.01	1	
I _{IL}	Driver low-level input current	D _I N = 0 V		-5	-40	μA
	Control low-level input current	$\overline{\text{SHDN}} = 0 V$		-0.01	-1	
I _{OS} ‡	Short-circuit output current	V _{CC} = 5.5 V, V _O = 0 V	±7	±22		mA
I _{off}	Output leakage current	V _{CC} = 5.5 V, $\overline{\text{SHDN}} = \text{GND}$, V _O = ±10 V		±0.01	±10	μA
r _o	Output resistance	V _{CC} , V ₊ , and V ₋ = 0 V, V _O = ±2 V	300	10 M		Ω

† All typical values are at V_{CC} = 5 V, and T_A = 25°C.

‡ Short-circuit durations should be controlled to prevent exceeding the device absolute power-dissipation ratings, and not more than one output should be shorted at a time.

NOTE 4: Test conditions are C1–C4 = 0.1 μF at V_{CC} = 5 V ± 0.5 V.

switching characteristics over recommended ranges of supply voltage and operating free-air temperature (unless otherwise noted) (see Note 4 and Figure 4)

PARAMETER		TEST CONDITIONS	MIN	TYP†	MAX	UNIT
	Data rate	C _L = 1000 pF, R _L = 3 kΩ, One D _O UT switching, See Figure 1	200			kbit/s
t _{PLH} (D)	Propagation delay time, low- to high-level output	See Figure 1		1.5	3.5	μs
t _{PHL} (D)	Propagation delay time, high- to low-level output	See Figure 1		1.3	3.5	μs
t _{PHL} (D) – t _{PLH} (D)	Driver (+ to –) propagation delay difference			300		ns
t _{sk(p)}	Pulse skew§	C _L = 150 pF to 2500 pF, R _L = 3 kΩ to 7 kΩ, See Figure 2		300		ns
SR(tr)	Slew rate, transition region (see Figure 1)	R _L = 3 kΩ to 7 kΩ, V _{CC} = 5 V, C _L = 50 pF to 2500 pF	6	12	30	V/μs
t _{ET}	Driver output enable time (after SHDN goes high)			250		μs
t _{DT}	Driver output disable time (after SHDN goes low)			300		ns

† All typical values are at V_{CC} = 5 V and T_A = 25°C.

§ Pulse skew is defined as |t_{PLH} – t_{PHL}| of each channel of the same device.

NOTE 4: Test conditions are C1–C4 = 0.1 μF at V_{CC} = 5 V ± 0.5 V.



MAX222
5-V DUAL RS-232 LINE DRIVER/RECEIVER
WITH ±15-kV ESD PROTECTION

SLLS590D – SEPTEMBER 2003 – REVISED AUGUST 2004

RECEIVER SECTION

electrical characteristics over recommended ranges of supply voltage and operating free-air temperature (unless otherwise noted) (see Note 4 and Figure 4)

PARAMETER		TEST CONDITIONS	MIN	TYP†	MAX	UNIT
V _{OH}	High-level output voltage	I _{OH} = -1 mA	3.5	V _{CC} - 0.2 V		V
V _{OL}	Low-level output voltage	I _{OL} = 3.2 mA			0.4	V
V _{IT+}	Positive-going input threshold voltage	V _{CC} = 5 V		1.7	2.4	V
V _{IT-}	Negative-going input threshold voltage	V _{CC} = 5 V	0.8	1.3		V
V _{hys}	Input hysteresis (V _{IT+} - V _{IT-})		0.2	0.5	1	V
r _i	Input resistance	V _I = ±3 V to ±25 V	3	5	7	kΩ

† All typical values are at V_{CC} = 5 V, and T_A = 25°C.

NOTE 4: Test conditions are C1–C4 = 0.1 μF at V_{CC} = 5 V ± 0.5 V.

switching characteristics over recommended ranges of supply voltage and operating free-air temperature (unless otherwise noted) (see Note 4 and Figure 3)

PARAMETER		TEST CONDITIONS	MIN	TYP†	MAX	UNIT
t _{PLH} (R)	Propagation delay time, low- to high-level output	C _L = 150 pF		0.6	1	μs
t _{PHL} (R)	Propagation delay time, high- to low-level output	C _L = 150 pF		0.5	1	μs
t _{PHL} (R) - t _{PLH} (R)	Receiver (+ to -) propagation delay difference			100		ns
t _{sk(p)}	Pulse skew‡			100		ns

† All typical values are at V_{CC} = 5 V and T_A = 25°C.

‡ Pulse skew is defined as |t_{PLH} - t_{PHL}| of each channel of the same device.

NOTE 4: Test conditions are C1–C4 = 0.1 μF, at V_{CC} = 5 V ± 0.5 V.

ESD protection

PIN	TEST CONDITIONS	TYP	UNIT
D _{OUT} , R _{IN}	Human-Body Model	±15	kV

MAX222
5-V DUAL RS-232 LINE DRIVER/RECEIVER
WITH ±15-kV ESD PROTECTION

SLLS590D – SEPTEMBER 2003 – REVISED AUGUST 2004

PARAMETER MEASUREMENT INFORMATION

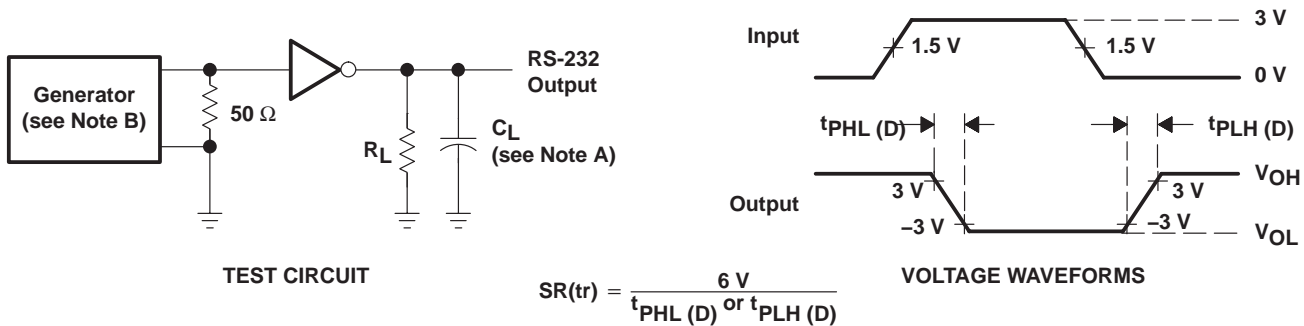

NOTES: A. C_L includes probe and jig capacitance.
 B. The pulse generator has the following characteristics: PRR = 250 kbit/s, $Z_O = 50\ \Omega$, 50% duty cycle, $t_r \leq 10\text{ ns}$, $t_f \leq 10\text{ ns}$.

Figure 1. Driver Slew Rate

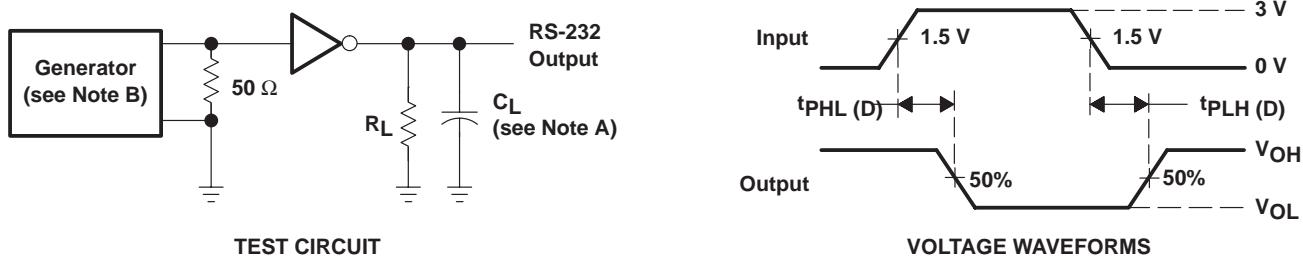

NOTES: A. C_L includes probe and jig capacitance.
 B. The pulse generator has the following characteristics: PRR = 250 kbit/s, $Z_O = 50\ \Omega$, 50% duty cycle, $t_r \leq 10\text{ ns}$, $t_f \leq 10\text{ ns}$.

Figure 2. Driver Pulse Skew

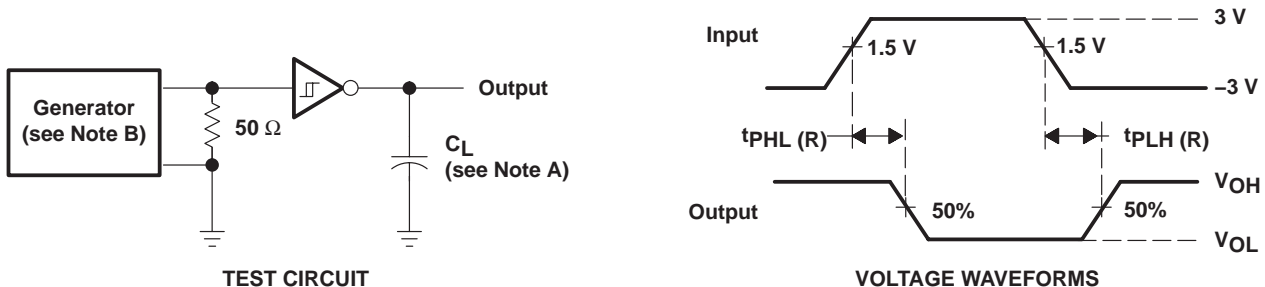

NOTES: A. C_L includes probe and jig capacitance.
 B. The pulse generator has the following characteristics: $Z_O = 50\ \Omega$, 50% duty cycle, $t_r \leq 10\text{ ns}$, $t_f \leq 10\text{ ns}$.

Figure 3. Receiver Propagation Delay Times

MAX222
5-V DUAL RS-232 LINE DRIVER/RECEIVER
WITH ± 15 -kV ESD PROTECTION

SLLS590D – SEPTEMBER 2003 – REVISED AUGUST 2004

APPLICATION INFORMATION

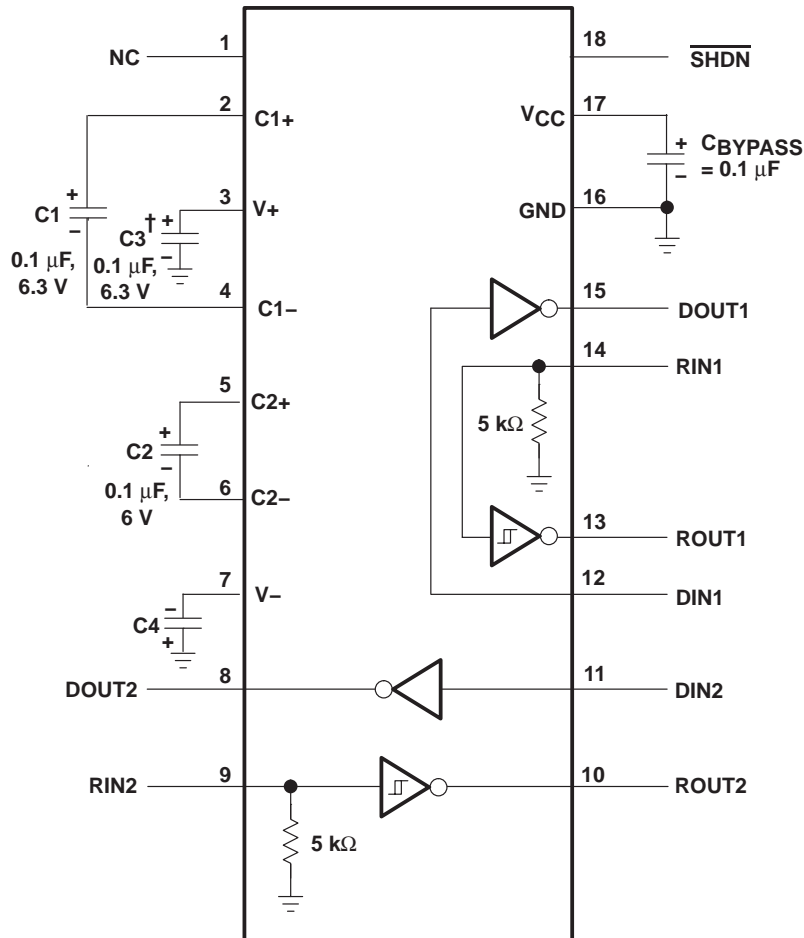

† C3 can be connected to V_{CC} or GND.

NOTES: A. Resistor values shown are nominal.

B. Nonpolarized ceramic capacitors are acceptable. If polarized tantalum or electrolytic capacitors are used, they should be connected as shown.

Figure 4. Typical Operating Circuit and Capacitor Values

MAX222

5-V DUAL RS-232 LINE DRIVER/RECEIVER

WITH ± 15 -kV ESD PROTECTION

SLLS590D – SEPTEMBER 2003 – REVISED AUGUST 2004

APPLICATION INFORMATION

capacitor selection

The capacitor type used for C1–C4 is not critical for proper operation. The MAX222 requires 0.1- μ F capacitors, although capacitors up to 10 μ F can be used without harm. Ceramic dielectrics are suggested for the 0.1- μ F capacitors. When using the minimum recommended capacitor values, ensure that the capacitance value does not degrade excessively as the operating temperature varies. If in doubt, use capacitors with a larger (e.g., 2 \times) nominal value. The capacitors' effective series resistance (ESR), which usually rises at low temperatures, influences the amount of ripple on V_+ and V_- .

Use larger capacitors (up to 10 μ F) to reduce the output impedance at V_+ and V_- .

Bypass V_{CC} to ground with at least 0.1 μ F. In applications sensitive to power-supply noise generated by the charge pumps, decouple V_{CC} to ground with a capacitor the same size as (or larger than) the charge-pump capacitors (C1–C4).

ESD protection

TI MAX222 devices have standard ESD protection structures incorporated on the pins to protect against electrostatic discharges encountered during assembly and handling. In addition, the RS232 bus pins (driver outputs and receiver inputs) of these devices have an extra level of ESD protection. Advanced ESD structures were designed to successfully protect these bus pins against ESD discharge of ± 15 -kV when powered down.

ESD test conditions

ESD testing stringently is performed by TI, based on various conditions and procedures. Contact TI for a reliability report that documents test setup, methodology, and results.

Human-Body Model

The Human-Body Model (HBM) of ESD testing is shown in Figure 5, while Figure 6 shows the current waveform that is generated during a discharge into a low impedance. The model consists of a 100-pF capacitor, charged to the ESD voltage of concern, and subsequently discharged into the DUT through a 1.5-k Ω resistor.

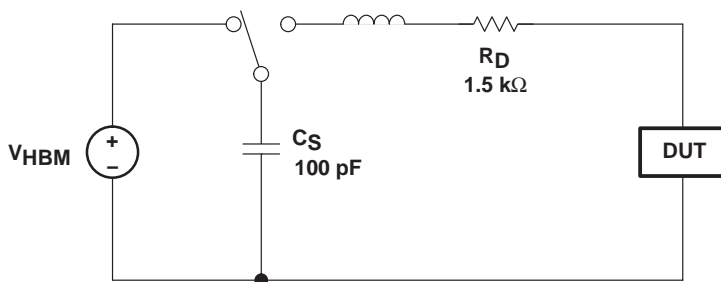

Figure 5. HBM ESD Test Circuit

APPLICATION INFORMATION

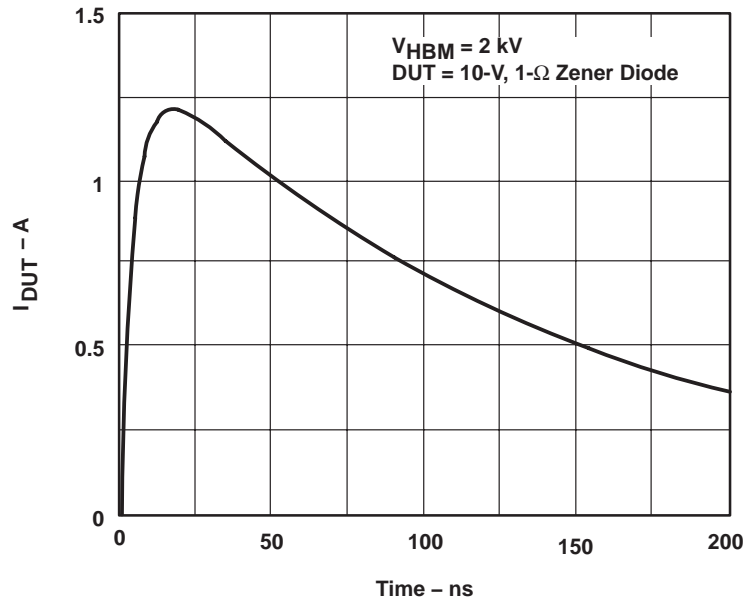

Figure 6. Typical HBM Current Waveform

Machine Model

The Machine Model (MM) ESD test applies to all pins using a 200-pF capacitor with no discharge resistance. The purpose of the MM test is to simulate possible ESD conditions that can occur during the handling and assembly processes of manufacturing. In this case, ESD protection is required for all pins, not just RS-232 pins. However, after PC board assembly, the MM test no longer is as pertinent to the RS-232 pins.

PACKAGING INFORMATION

Orderable Device	Status (1)	Package Type	Package Drawing	Pins	Package Qty	Eco Plan (2)	Lead/Ball Finish (6)	MSL Peak Temp (3)	Op Temp (°C)	Device Marking (4/5)	Samples
MAX222CDW	ACTIVE	SOIC	DW	18	40	Green (RoHS & no Sb/Br)	NIPDAU	Level-2-260C-1 YEAR	0 to 70	MAX222C	Samples
MAX222CDWR	ACTIVE	SOIC	DW	18	2000	Green (RoHS & no Sb/Br)	NIPDAU	Level-2-260C-1 YEAR	0 to 70	MAX222C	Samples
MAX222IDW	ACTIVE	SOIC	DW	18	40	Green (RoHS & no Sb/Br)	NIPDAU	Level-2-260C-1 YEAR	-40 to 85	MAX222I	Samples
MAX222IDWR	ACTIVE	SOIC	DW	18	2000	Green (RoHS & no Sb/Br)	NIPDAU	Level-2-260C-1 YEAR	-40 to 85	MAX222I	Samples
MAX222IDWRG4	ACTIVE	SOIC	DW	18	2000	Green (RoHS & no Sb/Br)	NIPDAU	Level-2-260C-1 YEAR	-40 to 85	MAX222I	Samples

(1) The marketing status values are defined as follows:

ACTIVE: Product device recommended for new designs.

LIFEBUY: TI has announced that the device will be discontinued, and a lifetime-buy period is in effect.

NRND: Not recommended for new designs. Device is in production to support existing customers, but TI does not recommend using this part in a new design.

PREVIEW: Device has been announced but is not in production. Samples may or may not be available.

OBSELETE: TI has discontinued the production of the device.

(2) **RoHS:** TI defines "RoHS" to mean semiconductor products that are compliant with the current EU RoHS requirements for all 10 RoHS substances, including the requirement that RoHS substance do not exceed 0.1% by weight in homogeneous materials. Where designed to be soldered at high temperatures, "RoHS" products are suitable for use in specified lead-free processes. TI may reference these types of products as "Pb-Free".

RoHS Exempt: TI defines "RoHS Exempt" to mean products that contain lead but are compliant with EU RoHS pursuant to a specific EU RoHS exemption.

Green: TI defines "Green" to mean the content of Chlorine (Cl) and Bromine (Br) based flame retardants meet JS709B low halogen requirements of <=1000ppm threshold. Antimony trioxide based flame retardants must also meet the <=1000ppm threshold requirement.

(3) MSL, Peak Temp. - The Moisture Sensitivity Level rating according to the JEDEC industry standard classifications, and peak solder temperature.

(4) There may be additional marking, which relates to the logo, the lot trace code information, or the environmental category on the device.

(5) Multiple Device Markings will be inside parentheses. Only one Device Marking contained in parentheses and separated by a "-" will appear on a device. If a line is indented then it is a continuation of the previous line and the two combined represent the entire Device Marking for that device.

(6) Lead/Ball Finish - Orderable Devices may have multiple material finish options. Finish options are separated by a vertical ruled line. Lead/Ball Finish values may wrap to two lines if the finish value exceeds the maximum column width.

Important Information and Disclaimer: The information provided on this page represents TI's knowledge and belief as of the date that it is provided. TI bases its knowledge and belief on information provided by third parties, and makes no representation or warranty as to the accuracy of such information. Efforts are underway to better integrate information from third parties. TI has taken and continues to take reasonable steps to provide representative and accurate information but may not have conducted destructive testing or chemical analysis on incoming materials and chemicals. TI and TI suppliers consider certain information to be proprietary, and thus CAS numbers and other limited information may not be available for release.

In no event shall TI's liability arising out of such information exceed the total purchase price of the TI part(s) at issue in this document sold by TI to Customer on an annual basis.

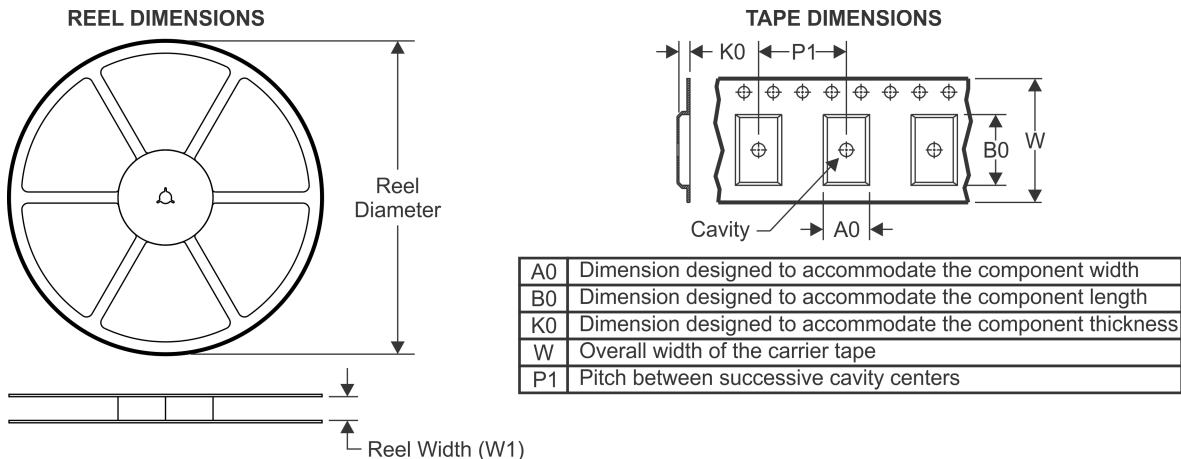
TAPE AND REEL INFORMATION

QUADRANT ASSIGNMENTS FOR PIN 1 ORIENTATION IN TAPE

*All dimensions are nominal

Device	Package Type	Package Drawing	Pins	SPQ	Reel Diameter (mm)	Reel Width W1 (mm)	A0 (mm)	B0 (mm)	K0 (mm)	P1 (mm)	W (mm)	Pin1 Quadrant
MAX222CDWR	SOIC	DW	18	2000	330.0	24.4	10.9	12.0	2.7	12.0	24.0	Q1
MAX222IDWR	SOIC	DW	18	2000	330.0	24.4	10.9	12.0	2.7	12.0	24.0	Q1

TAPE AND REEL BOX DIMENSIONS

*All dimensions are nominal

Device	Package Type	Package Drawing	Pins	SPQ	Length (mm)	Width (mm)	Height (mm)
MAX222CDWR	SOIC	DW	18	2000	370.0	355.0	55.0
MAX222IDWR	SOIC	DW	18	2000	370.0	355.0	55.0

N (R-PDIP-T**)

PLASTIC DUAL-IN-LINE PACKAGE

16 PINS SHOWN



- NOTES:
- A. All linear dimensions are in inches (millimeters).
 - B. This drawing is subject to change without notice.
 - Falls within JEDEC MS-001, except 18 and 20 pin minimum body length (Dim A).
 - The 20 pin end lead shoulder width is a vendor option, either half or full width.

DW (R-PDSO-G18)

PLASTIC SMALL OUTLINE

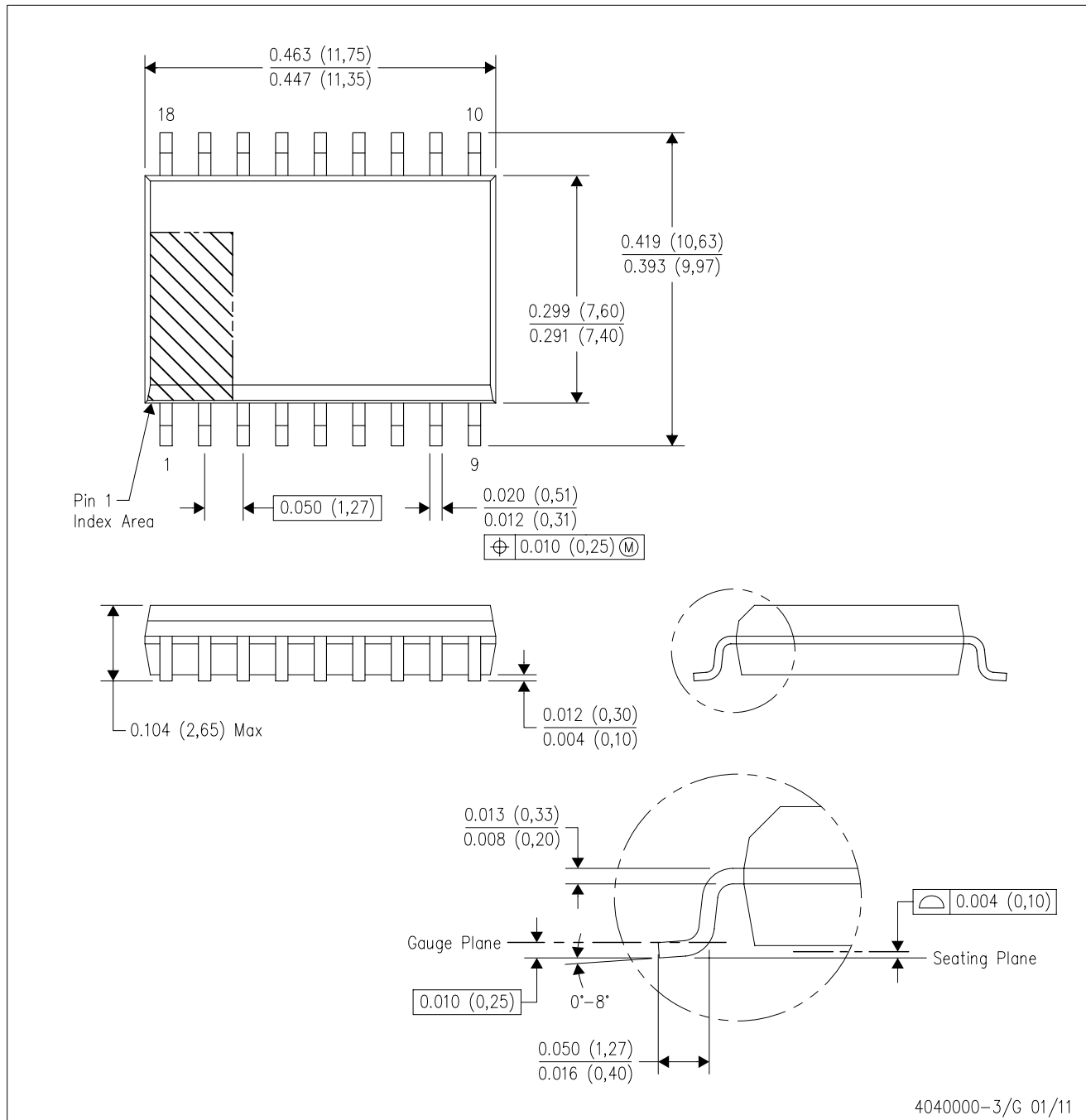

- NOTES:
- A. All linear dimensions are in inches (millimeters). Dimensioning and tolerancing per ASME Y14.5M-1994.
 - B. This drawing is subject to change without notice.
 - C. Body dimensions do not include mold flash or protrusion not to exceed 0.006 (0,15).
 - D. Falls within JEDEC MS-013 variation AB.

DW (R-PDSO-G18)

PLASTIC SMALL OUTLINE

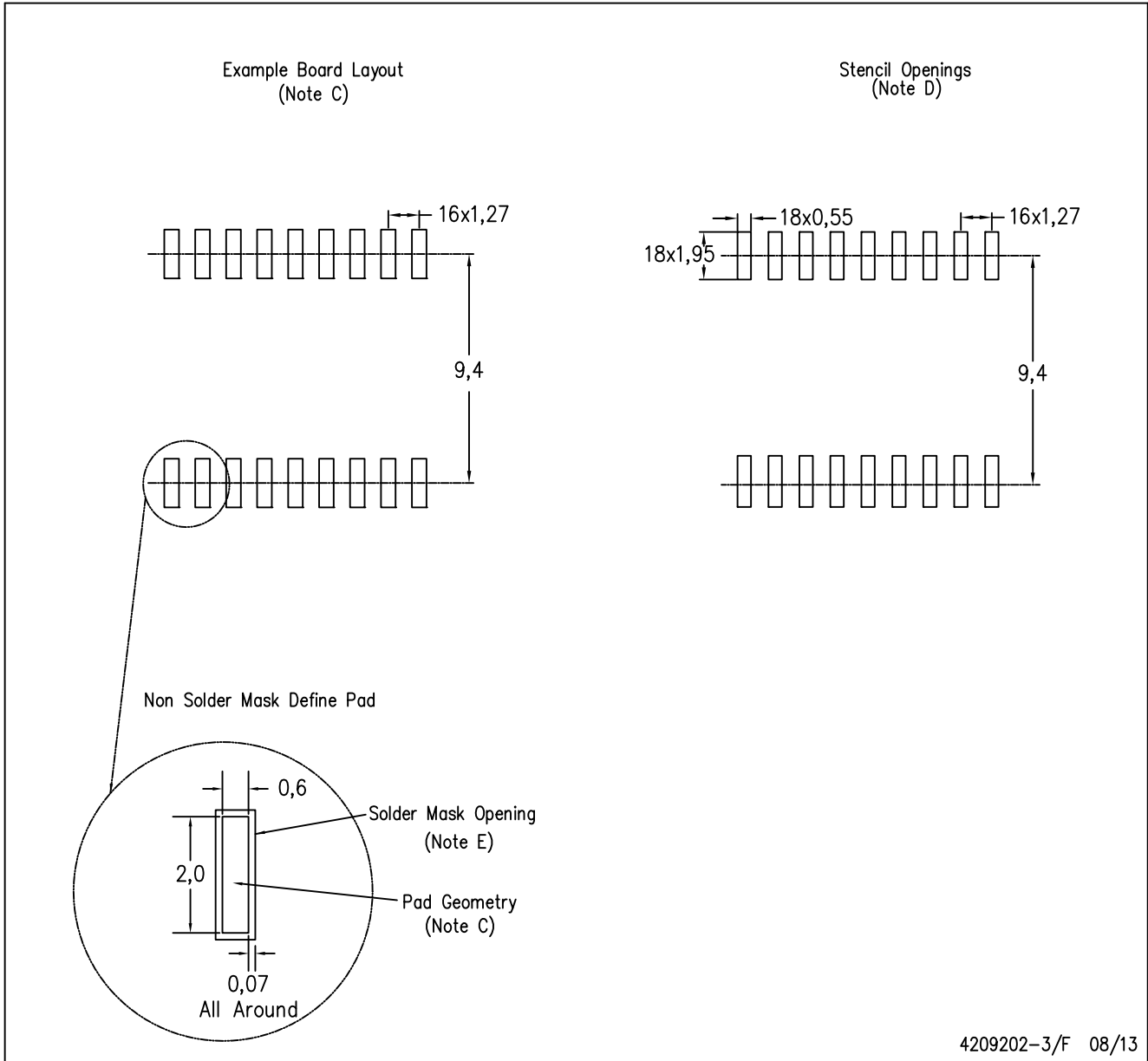

4209202-3/F 08/13

- NOTES:
- A. All linear dimensions are in millimeters.
 - B. This drawing is subject to change without notice.
 - C. Refer to IPC7351 for alternate board design.
 - D. Laser cutting apertures with trapezoidal walls and also rounding corners will offer better paste release. Customers should contact their board assembly site for stencil design recommendations. Refer to IPC-7525
 - E. Customers should contact their board fabrication site for solder mask tolerances between and around signal pads.

IMPORTANT NOTICE AND DISCLAIMER

TI PROVIDES TECHNICAL AND RELIABILITY DATA (INCLUDING DATASHEETS), DESIGN RESOURCES (INCLUDING REFERENCE DESIGNS), APPLICATION OR OTHER DESIGN ADVICE, WEB TOOLS, SAFETY INFORMATION, AND OTHER RESOURCES "AS IS" AND WITH ALL FAULTS, AND DISCLAIMS ALL WARRANTIES, EXPRESS AND IMPLIED, INCLUDING WITHOUT LIMITATION ANY IMPLIED WARRANTIES OF MERCHANTABILITY, FITNESS FOR A PARTICULAR PURPOSE OR NON-INFRINGEMENT OF THIRD PARTY INTELLECTUAL PROPERTY RIGHTS.

These resources are intended for skilled developers designing with TI products. You are solely responsible for (1) selecting the appropriate TI products for your application, (2) designing, validating and testing your application, and (3) ensuring your application meets applicable standards, and any other safety, security, or other requirements. These resources are subject to change without notice. TI grants you permission to use these resources only for development of an application that uses the TI products described in the resource. Other reproduction and display of these resources is prohibited. No license is granted to any other TI intellectual property right or to any third party intellectual property right. TI disclaims responsibility for, and you will fully indemnify TI and its representatives against, any claims, damages, costs, losses, and liabilities arising out of your use of these resources.

TI's products are provided subject to TI's Terms of Sale (www.ti.com/legal/termsofsale.html) or other applicable terms available either on ti.com or provided in conjunction with such TI products. TI's provision of these resources does not expand or otherwise alter TI's applicable warranties or warranty disclaimers for TI products.

Mailing Address: Texas Instruments, Post Office Box 655303, Dallas, Texas 75265
Copyright © 2020, Texas Instruments Incorporated