

60V, 4A Synchronous Step-Down Regulator for Inverting Outputs

FEATURES

- Wide V_{IN} Range: 3.4V to 60V
- Wide V_{OUT} Range: 0V to -28V
- Single Resistor V_{OUT} Programming
- Integrated 110mΩ Top N-Channel/50mΩ Bottom N-Channel MOSFETs
- Regulated I_Q : 440μA, Shutdown I_Q : 15μA
- Board GND Referenced I/O Pins (RUN, PGOOD, MODE/SYNC)
- Accurate Resistor Programmable Frequency (300kHz to 3MHz) with ±50% Frequency Sync Range
- 92% Efficiency with 12 V_{IN} and -5 V_{OUT}
- ±0.8% Output Voltage Accuracy
- Peak Current Mode Operation
- Burst Mode® Operation, Forced Continuous Mode
- Programmable Soft-Start
- Overtemperature Protection
- Available in 28-Lead (4mm x 5mm) QFN and TSSOP Packages

APPLICATIONS

- Industrial Applications
- Telecom Power Supplies
- Distributed Power Systems

DESCRIPTION

The LTC7149 is a high efficiency 60V, 4A synchronous monolithic step-down regulator for inverting output applications. The regulator features a single resistor-programmable output voltage and high efficiency over a wide V_{OUT} range.

The inverting regulator operates from an input voltage range of 3.4V to 60V and provides an adjustable output from (-28V) to zero volts while delivering up to 4A of inductor current. The switching frequency is also set with an external resistor. A user-selectable mode input is provided to allow the user to trade off ripple noise for efficiency at light loads; Burst Mode operation provides the highest efficiency at light loads, while forced continuous mode provides low output ripple. The MODE/SYNC pin can also be used to synchronize the switching frequency to an external clock. Internal level-shift circuits allow the I/O pins (RUN, MODE/SYNC, PGOOD) to be referenced to board GND.

The LTC7149 operates with a peak current mode architecture that allows for fast transient response with inherent cycle-to-cycle current limit protection.

All registered trademarks and trademarks are the property of their respective owners. Protected by U.S. Patents, including 5481178, 5705919, 5847554, 6580258.

TYPICAL APPLICATION

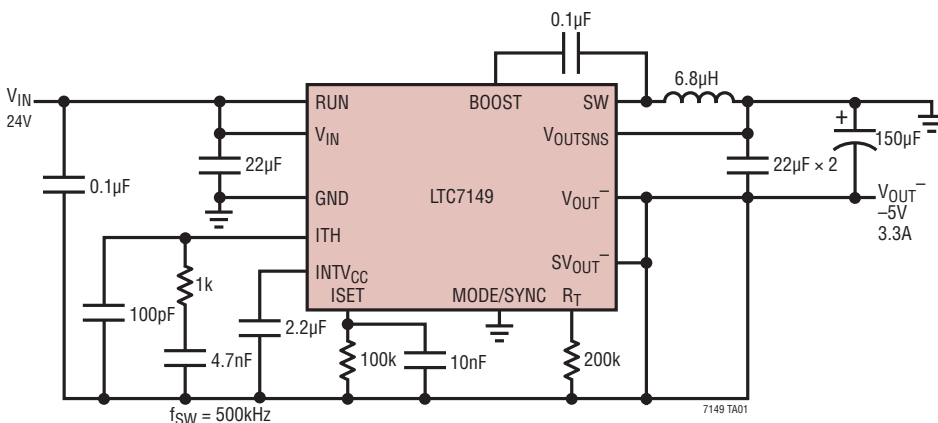

Efficiency with $V_{OUT} = -5V$

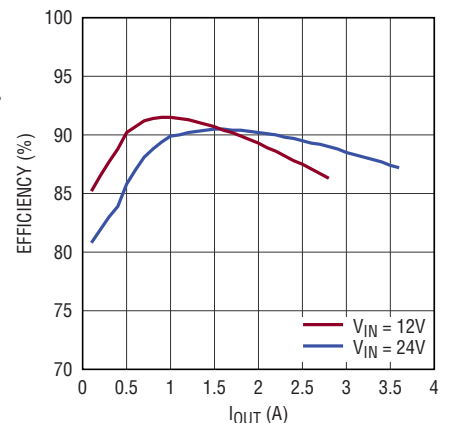

7149 TA01b

7149fa

LTC7149

ABSOLUTE MAXIMUM RATINGS

(Note 1)

| | |
|----------------------------|-----------------------|
| V_{IN} Voltage* (Note 3) | 64V to -0.3V |
| ISET Voltage* | V_{IN} to -0.3V |
| GND Voltage* | 28V to -0.3V |
| RUN Voltage* | 64V to GND -0.3V |
| MODE/SYNC, PGOOD Voltage* | GND + 6V to GND -0.3V |
| V_{OUTSNS} Voltage* | V_{IN} to -0.3V |

| | |
|---|--|
| R_T , PGDFB, ITH, V_{INREG} | INTV _{CC} +0.3V to (SV_{OUT-} -0.3V) |
| EXTV _{CC} Voltage* | 28V to -0.3V |
| Operating Junction Temperature Range (Notes 4, 6) | -40°C to 125°C |
| Storage Temperature Range | -65°C to 125°C |

*All voltage referenced to V_{OUT-} , unless otherwise specified.

PIN CONFIGURATION

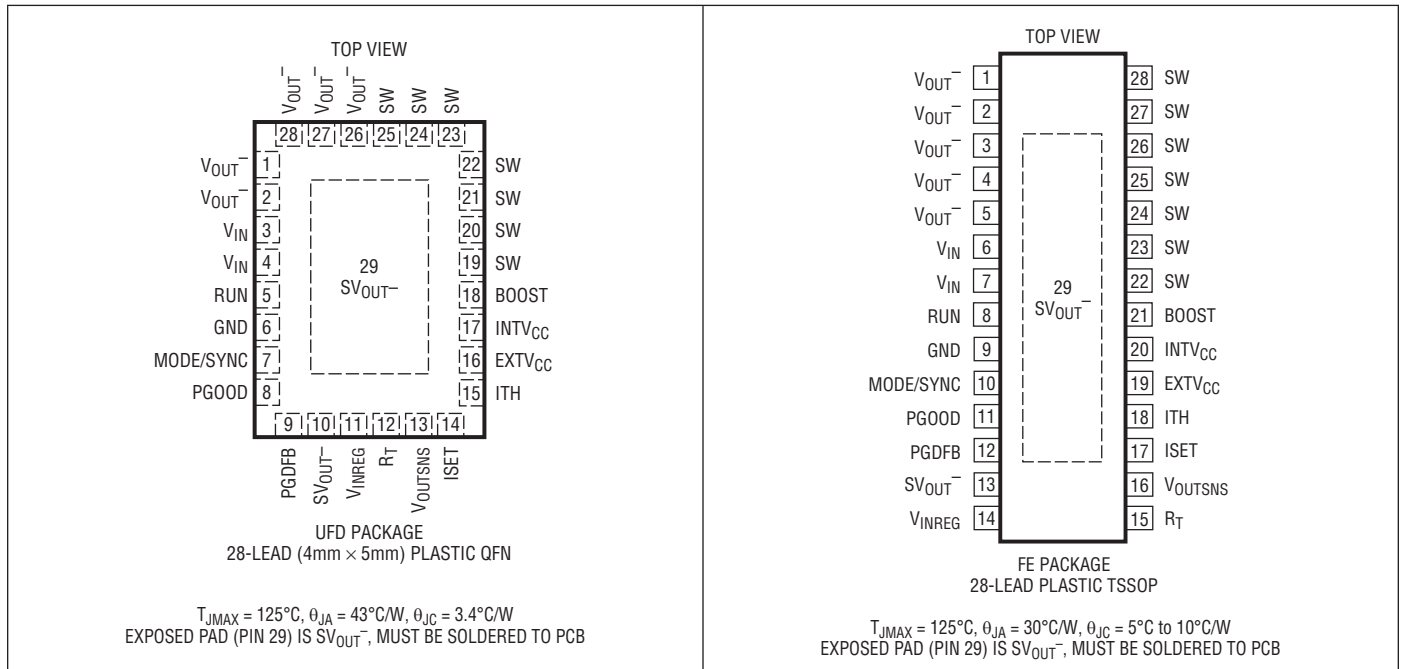

ORDER INFORMATION <http://www.linear.com/product/LTC7149#orderinfo>

| LEAD FREE FINISH | TAPE AND REEL | PART MARKING* | PACKAGE DESCRIPTION | TEMPERATURE RANGE |
|------------------|--------------------|---------------|---------------------------------|-------------------|
| LTC7149EUFDPBF | LTC7149EUFDPBTRPBF | 7149 | 28-Lead (4mm × 5mm) Plastic QFN | -40°C to 125°C |
| LTC7149IUFDPBF | LTC7149IUFDPBTRPBF | 7149 | 28-Lead (4mm × 5mm) Plastic QFN | -40°C to 125°C |
| LTC7149EFE#PBF | LTC7149EFE#TRPBF | LTC7149 | 28-Lead Plastic TSSOP | -40°C to 125°C |
| LTC7149IFE#PBF | LTC7149IFE#TRPBF | LTC7149 | 28-Lead Plastic TSSOP | -40°C to 125°C |

Consult ADI Marketing for parts specified with wider operating temperature ranges. *The temperature grade is identified by a label on the shipping container.

For more information on lead free part marking, go to: <http://www.linear.com/leadfree/>

For more information on tape and reel specifications, go to: <http://www.linear.com/tapeandreel/>. Some packages are available in 500 unit reels through designated sales channels with #TRMPBF suffix.

ELECTRICAL CHARACTERISTICS

The ● denotes the specifications which apply over the specified operating junction temperature range, otherwise specifications are at $T_A = 25^\circ\text{C}$. (Note 2) $V_{IN} = 24\text{V}$, $V_{EXTVCC} = 0\text{V}$ unless otherwise specified.

| SYMBOL | PARAMETER | CONDITIONS | MIN | TYP | MAX | UNITS |
|-----------------------------|--|--|----------------|--------------------|-------------------|--------------------------------------|
| V_{IN} | Input Supply Operating Voltage Range | | 3.4 | 60 – $ V_{OUT^-} $ | | V |
| V_{OUT^-} | Output Operating Voltage Range | (Note 3) | –28V | | –0.05 | V |
| I_{VIN} | Input Quiescent Current | Shutdown Mode; $V_{RUN} = 0\text{V}$ Burst Mode Operation FC Mode (Note 5) | | 18 440 1.4 | 30 600 2.5 | μA μA mA |
| I_{ISET} | Reference Current | $V_{ISET} + V_{OUT^-} = 3.3\text{V}$ | ● 49.6 49.4 | 50 50 | 50.4 50.6 | μA μA |
| $\Delta V_{OUT(Load+Line)}$ | Output Voltage Load + Line Regulation | | ● | 0.1 | 0.5 | % |
| $V_{EA(OFFSET)}$ | Error Amp Input Offset | $V_{ISET} = 3.3\text{V}$ | | –5 | 5 | mV |
| g_m (EA) | Error Amplifier Transconductance | $V_{I_{TH}} + V_{OUT^-} = 0.7\text{V}$, $V_{OUT^-} = -3.3\text{V}$ | | 400 | 550 700 | μS |
| I_{LSW} | Topside NMOS Switch Leakage | | | 0.1 | 1 | μA |
| R_{SW} | Resistance to V_{OUT^-} | | 0.5 | 1 | 1.5 | M Ω |
| $R_{DS(ON)}$ | Topside NMOS On-Resistance Bottom Side NMOS On-Resistance | | | 110 50 | | m Ω m Ω |
| $t_{ON(MIN)}$ | Minimum On-Time | | | 60 | | ns |
| V_{RUN} | RUN Input Rising RUN Hysteresis | | ● 1.08 | 1.2 120 | 1.32 | V mV |
| I_{RUN} | RUN Input Current | $V_{RUN} = 12\text{V}$ | | 0 | 10 | nA |
| $V_{MODE/SYNC}$ | Burst Mode Operation FC Mode | $V_{MODE/SYNC} = 0\text{V}$ | | 1.2 | 0.4 | V V |
| $I_{MODE/SYNC}$ | MODE/SYNC Input Current | $V_{MODE/SYNC} = 0\text{V}$ | | –8 | –5 | μA |
| I_{LIM} | Peak Current Limit | | ● 5.7 5.4 | 6 6 | 6.3 6.6 | A A |
| V_{UVLO} | $V_{INTVCC} + V_{OUT^-} $ Undervoltage Lockout | V_{IN} Rising | ● 2.4 | 2.65 | 2.9 | V |
| $V_{UVLO(HYS)}$ | $V_{INTVCC} + V_{OUT^-} $ Undervoltage Lockout Hysteresis | | | 200 | | mV |
| V_{OVLO} | V_{IN} Overvoltage Lockout Rising ($V_{IN} + V_{OUT^-} $) | | 64 | 68 | | V |
| $V_{OVLO(HYS)}$ | V_{IN} Overvoltage Lockout Hysteresis | | | 2 | 4 | V |
| f_{OSC} | Oscillator Frequency | $R_T = 100\text{k}\Omega$ | ● 0.92 | 1 | 1.08 | MHz |
| f_{SYNC} | SYNC Capture Range | % of Programmed Frequency | | 50 | 150 | % |
| V_{INTVCC} | V_{INTVCC} LDO Output Voltage ($V_{INTVCC} + V_{OUT^-} $) | $V_{IN} > 3.6\text{V}$, $V_{EXTVCC} + V_{OUT^-} = 0\text{V}$ $V_{IN} > 5.0\text{V}$, $V_{EXTVCC} + V_{OUT^-} > 3.2\text{V}$ | | 3.25 2.85 | 3.45 3 3.15 | V V |
| V_{EXTVCC} | EXTVCC Switchover Voltage | $V_{EXTVCC} + V_{OUT^-} $ | ● 3.1 3.25 | 3.15 | 3.2 | V V |
| $R_{VOUTSNS}$ | V_{OUTSNS} Resistance to SV_{OUT^-} | | | 80 | 100 120 | k Ω |
| I_{PGDFB} | PGDFB Leakage Current | $V_{PGDFB} = 0.6\text{V}$ | | 0 | 100 | nA |
| OV_{PGDFB} | Output Overvoltage PGOOD Upper Threshold | $V_{PGFB} + V_{OUT^-} $ Rising | | 0.63 | 0.645 0.66 | V |
| UV_{PGDFB} | Output Undervoltage PGOOD Lower Threshold | $V_{PGFB} + V_{OUT^-} $ Falling | | 0.54 | 0.555 0.57 | V |
| ΔV_{PGDFB} | PGOOD Hysteresis | | | 10 | | mV |
| R_{PGOOD} | PGOOD Pull-Down Resistance | | | 550 | | Ω |
| $I_{PGOOD(LEAK)}$ | PGOOD Leakage Current | $V_{PGOOD} = 3.3\text{V}$ | | | 100 | nA |

ELECTRICAL CHARACTERISTICS

| SYMBOL | PARAMETER | CONDITIONS | MIN | TYP | MAX | UNITS |
|--------------|---|-------------------|------|-----|------|---------------|
| t_{PGOOD} | PGOOD Delay | PGOOD Low to High | | 16 | | Switch Cycles |
| | | PGOOD High to Low | | 64 | | |
| V_{VINREG} | Input Voltage Regulation Voltage ($V_{INREG} + V_{OUT-} $) | | 1.85 | 2 | 2.15 | V |
| I_{VINREG} | V_{INREG} Leakage Current | | | 0 | 100 | nA |

Note 1: Stresses beyond those listed under Absolute Maximum Ratings may cause permanent damage to the device. Exposure to any Absolute Maximum Rating condition for extended periods may affect device reliability and lifetime.

Note 2: Transient absolute maximum voltages should not be applied for more than 4% of the switching duty cycle.

Note 3: Minimum On-time considerations need to be taken into account when regulating to an output voltage close to zero. Refer to minimum on-time section in Operations for more details.

Note 4: The LTC7149 is tested under pulsed load conditions such that $T_J \approx T_A$. The LTC7149E is guaranteed to meet specifications from 0°C to 85°C junction temperature. Specifications over the -40°C to

125°C operating junction temperature range are assured by design, characterization and correlation with statistical process controls. The LTC7149I is guaranteed over the full -40°C to 125°C operating junction temperature range. Note that the maximum ambient temperature consistent with these specifications is determined by specific operating conditions in conjunction with board layout, the rated package thermal impedance and other environmental factors.

Note 5: The quiescent current in FC mode does not include switching loss of the power FETs.

Note 6: This IC includes overtemperature protection that is intended to protect the device during momentary overload conditions. Junction temperature will exceed 125°C when overtemperature protection is active. Continuous operation above the specified maximum operating junction temperature may impair device reliability.

TYPICAL PERFORMANCE CHARACTERISTICS

Load Regulation

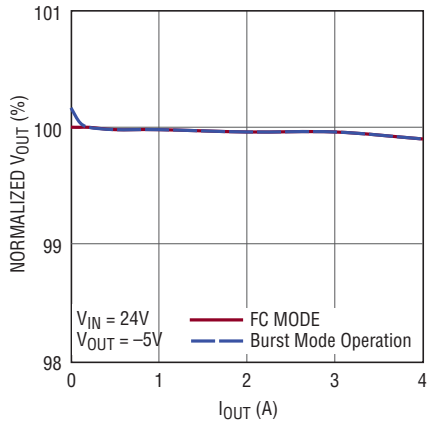

7149 G01

ISET Current vs Temperature

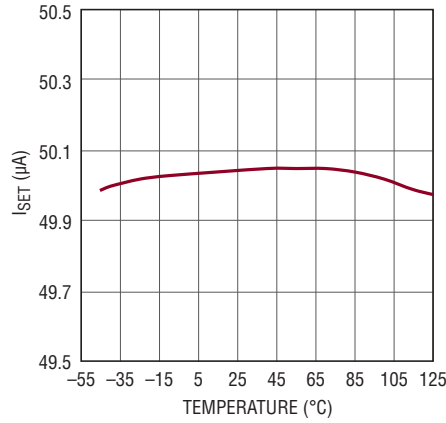

7149 G02

ISET Current vs V_{ISET}

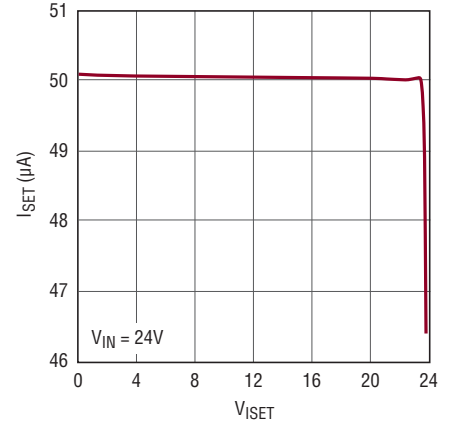

7149 G03

ISET Voltage Line Regulation

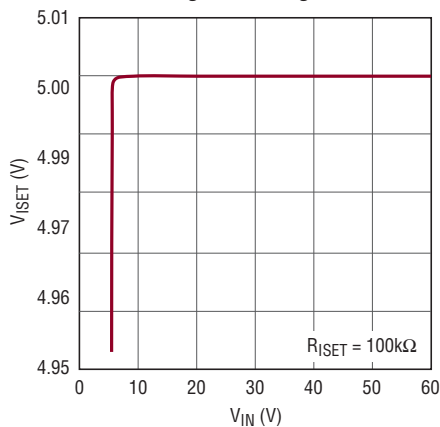

7149 G04

Quiescent Current vs Temperature

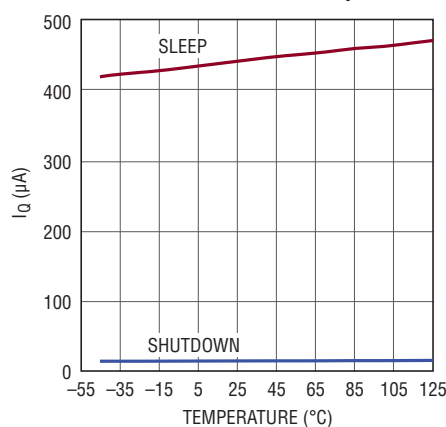

7149 G05

Shutdown Current vs VIN

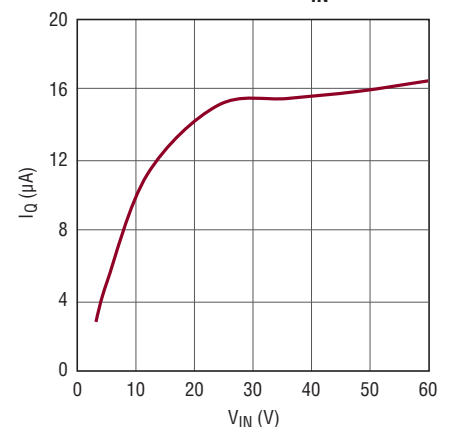

7149 G06

R_{DS(ON)} vs Temperature

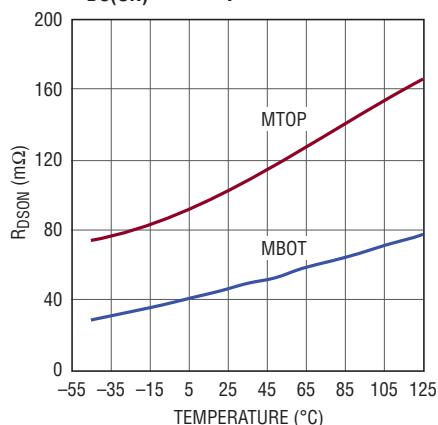

7149 G07

Transient Response, CCM

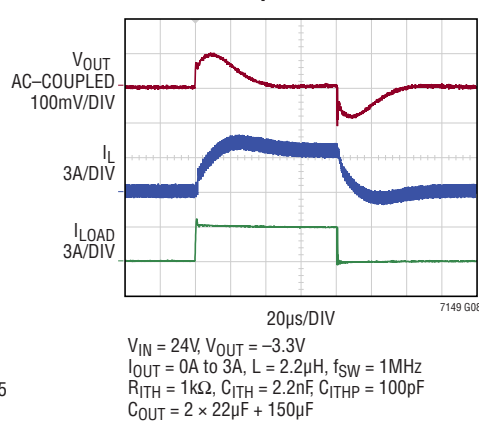

7149 G08

Transient Response, DCM

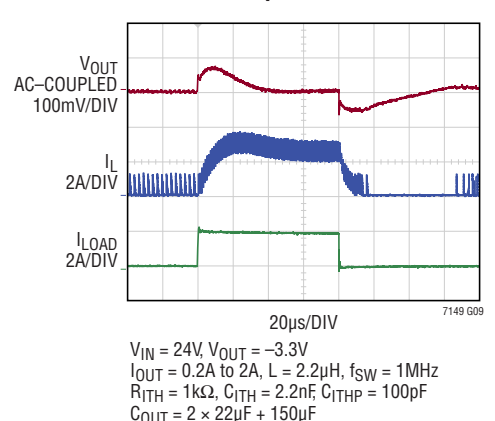

7149 G09

TYPICAL PERFORMANCE CHARACTERISTICS

Switching Frequency/Period vs R_T

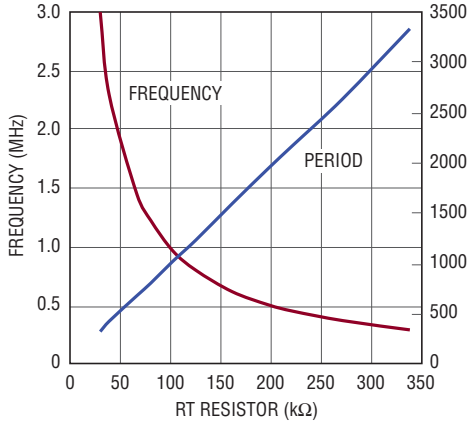

7149 G10

Switching Frequency vs Temperature

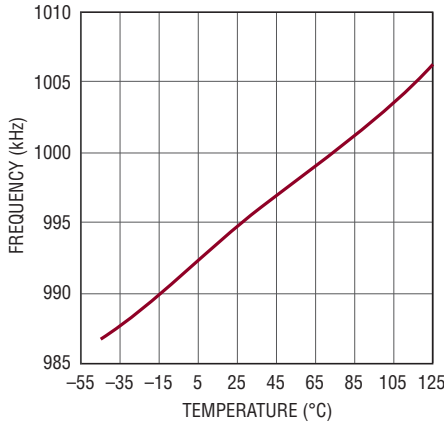

7149 G11

Start-Up Waveform

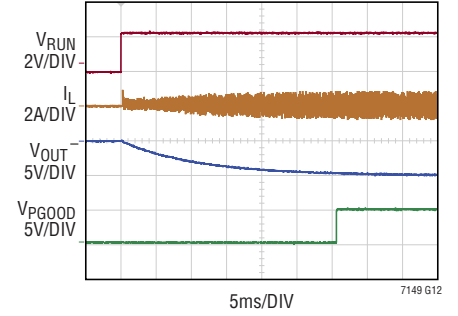

7149 G12

Discontinuous Conduction Mode Operation

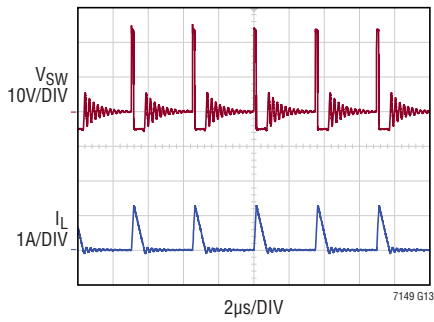

7149 G13

Continuous Conduction Mode Operation

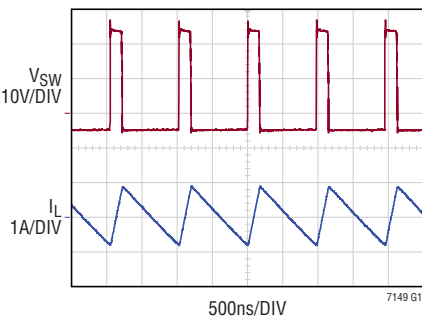

7149 G14

Run Rising Threshold vs Temperature

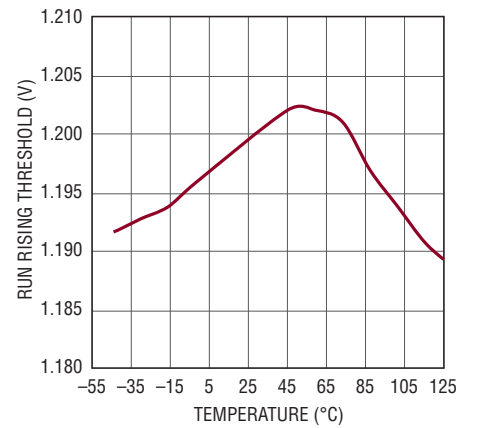

7149 G15

Maximum Output Current vs Input Voltage

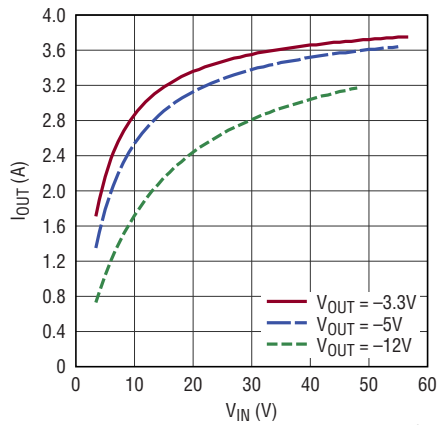

7149 G16

Efficiency vs Load Current, $V_{OUT} = -5V$

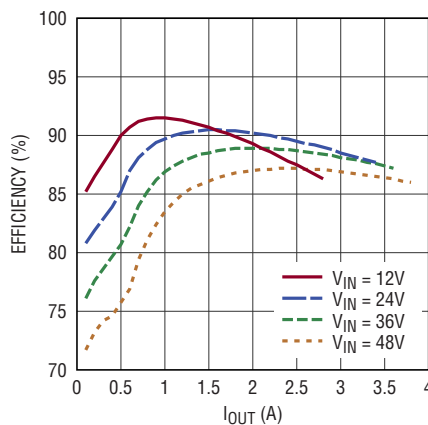

7149 G17

Efficiency vs Load Current, $V_{OUT} = -12V$

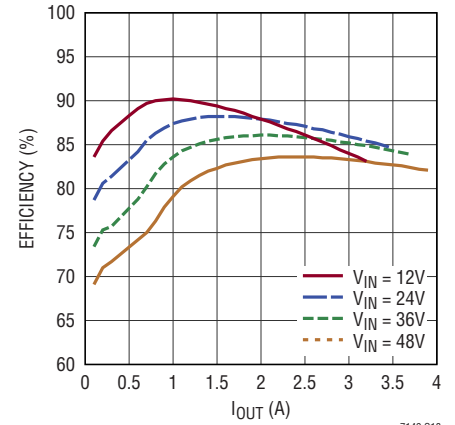

7149 G18

PIN FUNCTIONS (QFN/TSSOP)

V_{OUT}^- (Pins 1, 2, 26-28/Pins 1-5): Negative Output of the Step-Down Regulator.

V_{IN} (Pin 3, 4/Pins 6, 7): Input Supply Pin of the Step-Down Regulator.

RUN (Pin 5/Pin 8): Logic Controlled RUN Input. Do not leave this pin floating. Place a resistor divider from V_{IN} to GND for an accurate V_{IN} undervoltage threshold.

GND (Pins 6/Pins 9): Board Ground Sense Pins. Connect pins to PCB ground.

MODE/SYNC (Pin 7/Pin 10): Mode Select and Oscillator Synchronization Input of the Step-Down Regulator. Leave MODE/SYNC floating for forced continuous mode operation or tie MODE/SYNC to GND for Burst Mode operation. Furthermore, connecting MODE/SYNC to an external clock will synchronize the internal oscillator to the external clock signal and put the part in forced continuous mode.

PGOOD (Pin 8/Pin 11): V_{OUT}^- Within Regulation Indicator. PGOOD is pulled to GND when V_{PGDFB} is more than 0.645V or less than 0.555V with respect to V_{OUT}^- .

PGDFB (Pin 9/Pin 12): Power Good Feedback. Place a resistor divider from GND to V_{OUT}^- to detect power good level.

VINREG (Pin 11/Pin 14): Input Voltage Regulation Sense Input. Place a resistor divider from V_{IN} to V_{OUT}^- to program the level of input voltage regulation. To disable feature, connect the pin to INTV_{CC}.

R_T (Pin 12/Pin 15): Oscillator Frequency Programming Pin. Connect an external resistor between 500k to 40k from R_T to SV_{OUT}^- to program the frequency from 200kHz to 2.5MHz respectively. Since the synchronization range is limited to $\pm 50\%$ of the set frequency, be sure that either

the external clock is within this range or R_T is set to accommodate the external clock for proper frequency lock.

V_{OUTSNS} (Pin 13/Pin 16): Output Voltage Error Amplifier Input Pin. For majority of applications, connect this pin to GND.

ISET (Pin 14/Pin 17): Accurate 50 μ A Bias Current and Positive Input to the Error Amplifier. Connect an external resistor from this pin to V_{OUT}^- to program the output voltage. Connecting an external capacitor from ISET to V_{OUT}^- will soft start the output voltage by reducing current inrush during start-up.

ITH (Pin 15/Pin 18): Error Amplifier Output and Switching Regulator Compensation Point. The current comparator's trip threshold is linearly proportional to this voltage. Tying this pin to INTV_{CC} activates internal compensation.

EXTV_{CC} (Pin 16/ Pin 19): External Power Input to the Internal Regulator. The internal regulator will draw current from EXTV_{CC} instead of V_{IN} when EXTV_{CC} is tied to a voltage higher than 3.2V above V_{OUT}^- and V_{IN} is 5V above V_{OUT}^- . For output voltages at or below $-3.3V$, this pin can be tied to GND. If this pin is tied to a supply other than GND, locally bypass with at least a 1 μ F to V_{OUT}^- .

INTV_{CC} (Pin 17/Pin 20): Low Dropout Regulator. Locally bypass with at least 1 μ F to V_{OUT}^- .

BOOST (Pin 18/Pin 21): Boosted Floating Driver Supply for Internal Top Power MOSFET. Place a 0.1 μ F bootstrap capacitor between BOOST and SW.

SW (Pins 19-25/Pins 22-28): Switch Node Connection to the Inductor of the Regulator.

SV_{OUT}^- (Pins 10, 29/Pins 13, 29): The exposed pad must be soldered to a PCB metal plane to SV_{OUT}^- for electrical connection and rated thermal performance.

FUNCTIONAL DIAGRAM

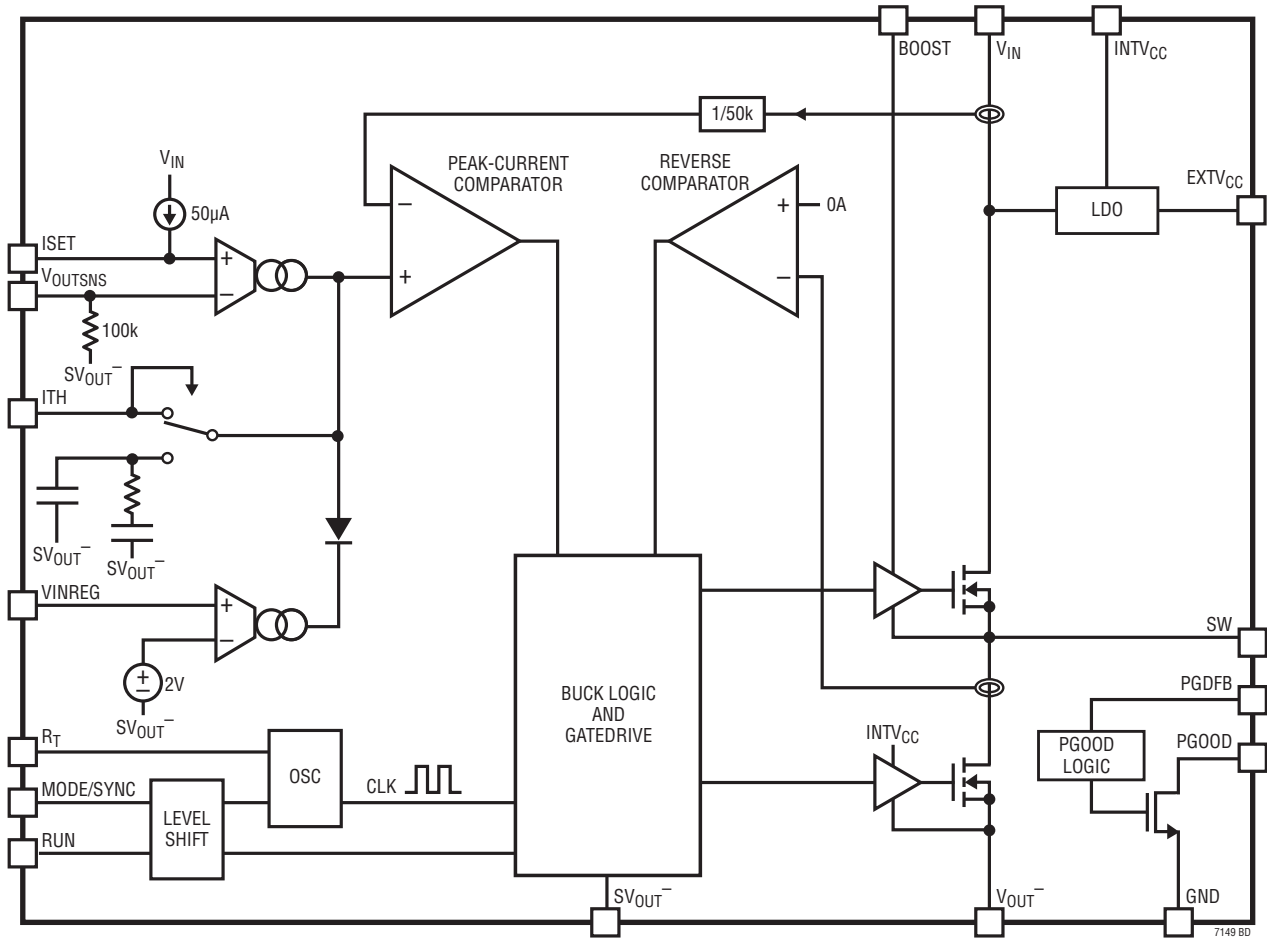

7149 BD

OPERATION

The LTC7149 is a current mode monolithic step-down regulator. The accurate 50 μ A bias current on the ISET pin allows the user to program the output voltage in a unity-gain buffer fashion with just one external resistor, R_{SET}, from the ISET pin to V_{OUT}⁻. The output voltage is set such that:

$$V_{OUT}^{-} = -50\mu A \cdot R_{SET}$$

The LTC7149 operates through a wide V_{IN} range, and its frequency can be programmed to a wide range with the R_T resistor. To suit a variety of applications, the MODE/SYNC pin allows the user to trade off output ripple for efficiency.

Main Control Loop

In normal operation, the internal top power MOSFET is turned on at the beginning of a clock pulse. The inductor current is allowed to ramp up to a peak level. Once that level is reached, the top power switch is turned off and the bottom switch is turned on until the next clock cycle. The peak inductor current is determined by sensing the voltage drop across the SW and V_{IN} nodes of the top power MOSFET. The voltage on the ITH pin sets the comparator threshold corresponding to inductor peak current. The error amplifier, EA, adjusts this ITH voltage by comparing the differential V_{OUTSNS} voltage to V_{OUT}⁻ with the voltage on ISET. In the typical application where the V_{OUTSNS} pin is tied to GND, if the load current into V_{OUT}⁻ increases, it causes an increase in V_{ISET} with respect to V_{OUTSNS}. This causes the ITH voltage to rise until the current into V_{OUT}⁻ provided by the regulator matches that of the load current.

Low Current Operation

Burst Mode operation can be selected by connecting the MODE/SYNC pin to GND. In this mode, the LTC7149 will automatically transition from continuous mode operation to Burst Mode operation when the load current is low. A reverse current comparator looks at the voltage across SW to GND and turns off the bottom power MOSFET when that voltage difference approaches zero. This prevents the inductor current from going negative. An internal burst clamp is set to be approximately 1A, which means that in Burst Mode, the peak inductor current will never go below 1A regardless of what the ITH voltage demands the peak

current to be. As a result, when the load is low enough, V_{OUTSNS} will rise relative to V_{ISET} because the average programmed inductor current is above the load current, thus driving V_{ITH} low. Once the ITH voltage is driven below an internal threshold (~400mV), the switching regulator will enter its sleep mode and wait for V_{OUT} to drop and V_{ITH} to rise above the threshold before it starts to switch again. During sleep mode, the quiescent current of the part is reduced to 440 μ A to conserve input power. The LTC7149 is designed to operate with single burst pulse behavior to minimize output voltage ripple while keeping the efficiency high at light loads. Lastly, if at any point the top power MOSFET is on for roughly 8 consecutive cycles, the part will turn on the bottom power MOSFET for a brief duration such that the BOOST capacitor can be replenished.

Forced Continuous Mode Operation

Floating the MODE/SYNC pin defaults the LTC7149 into forced continuous mode operation. In this mode, the part switches continuously regardless of load current, and the inductor peak current is allowed to decrease to approximately -1A to allow for significant negative average current.

High Duty Cycle/Dropout Operation

As the input voltage decreases towards the desired output voltage, the duty cycle will increase towards 100%. However, given the architecture, there are two restrictions that prevent the LTC7149 from operating in full dropout mode.

The first restriction is due to how the ISET voltage is programmed. If a resistor is placed between ISET and V_{OUT}⁻ to set the output voltage, the 50 μ A of current out of the ISET pin is only guaranteed to be accurate when V_{ISET} is more than 500mV below V_{IN}. As the input voltage drops below that 500mV threshold, the ISET current will decrease, thus limiting the programmed voltage. Typically, V_{ISET} will never get within 300mV of V_{IN}. Since V_{ISET} programs V_{OUT}⁻, this limitation essentially enforces a maximum duty cycle for the switcher. This limitation can be overcome if an accurate external supply is used to drive the ISET pin directly.

OPERATION

The second limitation against full dropout operation is the requirement for the BOOST to SW capacitor to refresh. When the top power MOSFET is on indefinitely during dropout operation, the BOOST to SW capacitor slowly gets depleted by the internal circuitry of the chip. When the bottom switch does not turn on for at least 80ns for 8 periods, it is forced to turn on in order to guarantee sufficient voltage on the bootstrap capacitor. During a refresh, the bottom switch will only turn on for roughly 30% of the period to limit inductor ripple, thus limiting output voltage ripple.

Input Voltage Regulation

In certain applications, the input supply to the power regulator can exhibit fairly high output impedance. As a result, when the regulator is running at heavy loads, V_{IN} might droop more than desired. The input voltage regulation loop allows the application to be programmed to decrease the peak inductor current level, and consequently the input current draw, when it senses that the input voltage has dropped below a programmed threshold. If V_{INREG} ever falls below 2V above V_{OUT-} , the regulator will decrease the output current level in order to maintain the 2V at the pin. If this feature is not required, tie the V_{INREG} pin to $INTV_{CC}$ to prevent this control loop from interfering with normal operation.

INTV_{CC} Regulator

The LTC7149 has two onboard internal low dropout (LDO) regulators that power the drivers and internal bias circuitry. Regardless of which one is in operation, the $INTV_{CC}$ must be bypassed to V_{OUT-} with a minimum of 2.2 μ F ceramic capacitor. Good bypassing is necessary to supply the high transient current required by the power MOSFET gate drivers.

The first LDO is powered from V_{IN} , and the $INTV_{CC}$ voltage is regulated to 3.3V above V_{OUT-} . The power dissipated across this LDO would thus be equal to $(V_{IN} + |V_{OUT-}| - 3.3V) \cdot I_{INTV_{CC}}$. For a typical 1MHz application running in CCM, the current drawn from $INTV_{CC}$ by the chip is roughly 20mA. Thus, if the input voltage is high, the power loss and heat rise due to this LDO might be quite significant.

To combat this issue, a separate LDO exists that is powered from $EXTV_{CC}$. As long as the input voltage is above 5V and the $EXTV_{CC}$ voltage is >3.2V above V_{OUT-} , this LDO will take over and regulate the $INTV_{CC}$ voltage to 3.1V above V_{OUT-} . In applications where the output voltage is programmed to -3.3V or below, it is recommended that the $EXTV_{CC}$ pin be directly tied to the GND pin. Furthermore, if a separate lower voltage rail exists on board that can supply $INTV_{CC}$ current, then attaching that supply to $EXTV_{CC}$ will also suffice provided that a 1 μ F ceramic bypass capacitor is placed from the $EXTV_{CC}$ pin to V_{OUT-} physically close to the chip. Both examples should significantly reduce the power loss through the LDO.

V_{IN} Undervoltage Programming

LTC7149 offers an accurate RUN threshold to start the regulator. As a result, a resistor divider from V_{IN} to GND can be placed with the intermediate node fed back to RUN to set an accurate V_{IN} undervoltage threshold. As the input voltage rises, the RUN voltage will increase above the V_{RUN} rising threshold (1.2V), and the regulator will turn on. Similarly, once on, if the input voltage decreases below the V_{RUN} falling threshold (1.1V), the regulator will turn off.

V_{IN} Overvoltage Protection

In order to protect the internal power MOSFET devices against transient voltage spikes, the LTC7149 constantly monitors the V_{IN} pin for an overvoltage condition. When $V_{IN} + |V_{OUT-}|$ rises above V_{OVLO} the regulator suspends operation by shutting off both power MOSFETs and discharges the ISET pin voltage to ground. Once V_{IN} drops below $V_{OVLO} - V_{OVLO(HYST)}$, the regulator resumes normal switching operation.

Programming Switching Frequency

Connecting a resistor from the R_T pin to SV_{OUT-} programs the switching frequency from 200kHz to 3MHz according to the following formula:

$$\text{Frequency (Hz)} = \frac{10^{11}(1/F)}{R_T(\Omega)}$$

Do not float the R_T pin.

OPERATION

The internal phase-locked loop has a synchronization range of $\pm 50\%$ around its programmed frequency. Therefore, during external clock synchronization, the proper R_T value should be selected such that the external clock frequency is within this 50% range of the R_T programmed frequency.

Output Voltage Tracking and Soft-Start

The LTC7149 allows the user to program its output voltage ramp rate by means of the ISET pin. Since V_{OUTSNS} servos its voltage to that of V_{ISET} , placing an external capacitor C_{SET} from the ISET pin to V_{OUT^-} will program the ramp-up rate of the ISET pin and thus the V_{OUT^-} voltage.

$$V_{OUT^-}(t) = I_{ISET} \cdot R_{SET} \left[1 - e^{-\frac{t}{R_{SET} \cdot C_{SET}}} \right]$$

From 0% to 90% V_{OUT^-} :

$$t_{SS} \cong -R_{SET} \cdot C_{SET} \cdot \ln(1 - 0.9)$$

$$t_{SS} \cong 2.3 \cdot R_{SET} \cdot C_{SET}$$

The soft-start time t_{SS} (from 0% to 90% of V_{OUT}) is 2.3 times the time constant ($R_{SET} \cdot C_{SET}$). The ISET pin can also be driven by an external supply capable of sinking $50\mu A$.

When starting up into a pre-biased V_{OUT^-} , the LTC7149 will stay in Burst Mode operation and keep the power switches off until the voltage on ISET has ramped up to be equal to V_{OUTSNS} , at which point the switcher will begin switching and V_{OUT^-} will start to decrease at the rate to maintain: $V_{ISET} = V_{OUTSNS}$.

Output Power Good

When the LTC7149's output voltage is within the 7.5% window of the regulation point, which is divided down as a V_{PGDFB} voltage in the range of 0.555V to 0.645V with respect to V_{OUT^-} , the output voltage is in regulation and the PGOOD pin is pulled high with an external resistor connected to a voltage rail less than 6V above GND. Otherwise, an internal open-drain pull-down device will pull the PGOOD pin low to GND. To prevent unwanted PGOOD glitches during transients or dynamic V_{OUT^-} changes, the

LTC7149's PGOOD falling edge includes a blanking delay of approximately 64 clock cycles.

Internal/External ITH Compensation

For ease of use, the user can simplify the loop compensation by tying the ITH pin to $INTV_{CC}$ to enable internal compensation. Because the internal compensation is required to provide a stable output voltage for a wide range of switching frequencies, it is designed to have a loop response that is typically much slower than optimal. This thus becomes a trade-off between simplicity and OPTI-LOOP® optimization, where ITH components are external and are selected to optimize the loop transient response with minimum output capacitance.

Minimum On-Time Considerations

Due to the architecture of the LTC7149, a minimum on-time restriction is imposed such that the top power MOSFET can have enough time to turn on and accurately determine if it has reached its peak current level before shutting off. The typical minimum on-time of the regulator is 60ns. Thus, given an application with varying input and output voltage ranges, the frequency must be designed to be slow enough to ensure the minimum on-time restriction is not violated.

In the rare cases where the minimum on-time restriction is violated, the frequency of the LTC7149 will automatically and gradually fold back down to one-fifth of its programmed switching frequency to allow the output to remain in regulation. This feature is designed for applications where the input voltage only experiences momentary spikes in voltage. In such applications, the frequency does not have to be programmed so slow to account for those momentary spikes, thus significantly saving component size and cost.

$$t_{ON(MIN)} = \frac{|V_{OUT^-}|}{V_{IN(MAX)} + |V_{OUT^-}|} \cdot \frac{1}{f_{SW}}$$

Choose the appropriate switching frequency to guarantee the $t_{ON(MIN)}$ does not approach the minimum on-time number.

The minimum on-time occurs at maximum V_{IN} .

APPLICATIONS INFORMATION

Input Capacitor (C_{IN}) Selection

The input capacitance, C_{IN}, is needed to filter the square wave current at the drain of the top power MOSFET. To prevent large input voltage droops from occurring, a low effective series resistance (ESR) input capacitor sized for the maximum RMS current should be used. The maximum RMS current is given by:

$$I_{\text{RMS}} \cong I_{\text{OUT(MAX)}} \cdot \sqrt{\frac{|V_{\text{OUT}}^-|}{V_{\text{IN}}}}$$

This formula has a maximum at $V_{\text{IN}} = |V_{\text{OUT}}^-|$, where $I_{\text{RMS}} \cong I_{\text{OUT}}$. This simple worst-case condition is commonly used for design because even significant deviations do not offer much relief. Note that ripple current ratings from capacitor manufacturers are often based on only 2000 hours of life which makes it advisable to further derate the capacitor, or choose a capacitor rated at a higher temperature than required. Several capacitors may also be paralleled to meet size or height requirements in the design. For low input voltage applications, sufficient bulk input capacitance is needed to minimize transient effects during output load changes.

Output Capacitor (C_{OUT}) Selection

The selection of C_{OUT} is determined by the ESR that is required to minimize voltage ripple and load step transients as well as the amount of bulk capacitance that is necessary to ensure that the control loop is stable. Loop stability can be checked by viewing the load transient response.

When the top power FET is on, the current into the V_{OUT}⁻ terminal of C_{OUT} is equal to the load current, I_{LOAD}. When the bottom power FET is on, the current into the V_{OUT}⁻

terminal of C_{OUT} is equal to the load current subtracted by the inductor current, I_L. In equilibrium, the charge lost during one phase is replenished in the other, and the output ripple, ΔV_{OUT(CHARGE)}⁻, is determined by:

$$\Delta V_{\text{OUT(CHARGE)}}^- \cong \frac{I_{\text{OUT}}}{f_{\text{SW}} \cdot C_{\text{OUT}}} \left(\frac{|V_{\text{OUT}}^-|}{V_{\text{IN}} + |V_{\text{OUT}}^-|} \right)$$

The ESR of the C_{OUT} is also a major factor in total output voltage ripple. The ripple due to ESR is:

ΔV_{OUT(ESR)} ≅ I_{LPK} • R_{ESR}, Where:

$$I_{\text{LPK}} = I_{\text{OUT}} \left(\frac{V_{\text{IN}} + |V_{\text{OUT}}^-|}{V_{\text{IN}}} \right) + \frac{V_{\text{IN}} \cdot |V_{\text{OUT}}^-|}{2f_{\text{SW}} \cdot L \cdot (V_{\text{IN}} + |V_{\text{OUT}}^-|)}$$

The total output voltage ripple is thus:

$$\Delta V_{\text{OUT}} = \Delta V_{\text{OUT(CHARGE)}}^- + \Delta V_{\text{OUT(ESR)}}$$

Multiple capacitors placed in parallel may be needed to meet the ESR and RMS current handling requirements. Dry tantalum, special polymer, aluminum electrolytic and ceramic capacitors are all available in surface mount packages. Special polymer capacitors are very low ESR but have lower capacitance density than other types. Tantalum capacitors have the highest capacitance density but it is important to only use types that have been surge tested for use in switching power supplies. Aluminum electrolytic capacitors have significantly higher ESR, but can be used in cost-sensitive applications provided that consideration is given to ripple current ratings and long-term reliability. Ceramic capacitors have excellent low ESR characteristics and small footprints.

APPLICATIONS INFORMATION

Using Ceramic Input and Output Capacitors

Higher value, lower cost ceramic capacitors are now becoming available in smaller case sizes. Their high ripple current, high voltage rating and low ESR make them ideal for switching regulator applications. However, care must be taken when these capacitors are used at the input and output. When only a ceramic capacitor is used at the input and the power is supplied by a wall adapter through long wires, a load step at the output can induce ringing at the input. At best, this ringing can couple to the output and be mistaken as loop instability. At worst, a sudden inrush of current through the long wires can potentially cause a voltage spike at V_{IN} large enough to damage the part.

When choosing the input and output ceramic capacitors, use X5R or X7R dielectric formulations. These dielectrics have the best temperature and voltage characteristics of all the ceramics for a given value and size.

Since the ESR of a ceramic capacitor is so low, the input and output capacitor must instead fulfill a charge storage requirement. During a load step, the output capacitor must instantaneously supply the current to support the load until the feedback loop raises the switch current enough to support the load.

More capacitance may be required depending on the duty cycle and load step requirements. In most applications, the input capacitor is merely required to supply high frequency bypassing, since the impedance to the supply is very low. A 22 μ F ceramic capacitor is usually enough for these conditions. Place this input capacitor as physically close to the V_{IN} pin as possible.

Inductor Selection

Given the desired input and output voltages, the inductor value and operating frequency determine the ripple current:

$$\Delta I_L = \frac{-V_{IN(MAX)}}{f_{SW} \cdot L} \left(\left| \frac{V_{OUT^-}}{V_{IN(MAX)} + |V_{OUT^-}|} \right| \right)$$

Lower ripple current reduces core losses in the inductor and reduces output voltage ripple. However, at extremes, low ripple causes inductor current sensing issues. Highest efficiency operation is obtained at low frequency with reasonably small ripple current. However, achieving this requires a large inductor. There is a trade-off between component size, efficiency and operating frequency.

A reasonable starting point is to choose a ripple current that is about 2A. To guarantee that ripple current does not exceed specified inductor saturation current ratings, the inductance should be chosen according to:

$$L = \frac{V_{IN(MAX)}}{f_{SW} \cdot \Delta I_L(MAX)} \left(\frac{|V_{OUT^-}|}{V_{IN(MAX)} + |V_{OUT^-}|} \right)$$

Once the value for L is known, the type of inductor must be selected. Core loss is very dependent on the material, frequency and inductance selected. Higher inductance reduces ripple. Unfortunately, increased inductance requires more turns of wire and therefore copper losses will increase.

Ferrite materials have very low core losses and are preferred at high switching frequencies, so design goals can minimize copper loss and preventing saturation. However, ferrite core material saturates “hard”, which means that inductance collapses abruptly when the peak design current is exceeded. This results in an abrupt increase in inductor ripple current and consequent output voltage ripple. Do not allow the core to saturate!

Different core materials and shapes will change the size/current and price/current relationship of an inductor. Toroid or shielded pot cores in ferrite or permalloy materials are small and don't radiate much energy, but generally cost more than powdered iron core inductors with similar characteristics. The choice of which style inductor to use mainly depends on the price versus size requirements and any radiated field/EMI requirements. New designs for surface mount inductors are available from Toko, Vishay, NEC/Tokin, Cooper, TDK and Würth Elektronik. Refer to Table 1 for more details.

APPLICATIONS INFORMATION

Table 1. Inductor Selection Table

| INDUCTOR | INDUCTANCE (μH) | DCR ($\text{m}\Omega$) | MAX CURRENT (A) | DIMENSIONS (mm) | HEIGHT (mm) | MANUFACTURER |
|-----------------------|------------------------------|--------------------------|-----------------|-----------------|-------------|---------------------------------------|
| XAL8080 Series | 4.7 | 8.89 | 17.4 | 8.6 × 8.1 | 8.0 | Coilcraft www.coilcraft.com |
| | 6.8 | 13.20 | 14.0 | 8.6 × 8.1 | 8.0 | |
| | 10.0 | 21.00 | 10.9 | 8.6 × 8.1 | 8.0 | |
| XAL1010 Series | 3.3 | 3.70 | 27.4 | 11.3 × 10 | 10.0 | Coilcraft www.coilcraft.com |
| | 4.7 | 5.20 | 25.4 | 11.3 × 10 | 10.0 | |
| | 5.6 | 6.30 | 23.6 | 11.3 × 10 | 10.0 | |
| | 6.8 | 8.10 | 21.8 | 11.3 × 10 | 10.0 | |
| | 8.2 | 11.70 | 18.3 | 11.3 × 10 | 10.0 | |
| | 10.0 | 13.40 | 17.5 | 11.3 × 10 | 10.0 | |
| FDV0840 Series | 2.1 | 10.40 | 10.6 | 9.1 × 8.4 | 4.0 | Toko www.toko.com |
| | 3.9 | 18.80 | 8.4 | 9.1 × 8.4 | 4.0 | |
| | 4.9 | 24.60 | 6.9 | 9.1 × 8.4 | 4.0 | |
| | 6.9 | 31.70 | 6.1 | 9.1 × 8.4 | 4.0 | |
| IHLP-4040DZ-A1 Series | 2.2 | 8.20 | 25.6 | 11.5 × 10.3 | 4.0 | Vishay www.vishay.com |
| | 3.3 | 13.70 | 18.6 | 11.5 × 10.3 | 4.0 | |
| | 4.7 | 15.00 | 17.0 | 11.5 × 10.3 | 4.0 | |
| | 5.6 | 17.60 | 16.0 | 11.5 × 10.3 | 4.0 | |
| | 6.8 | 21.20 | 13.5 | 11.5 × 10.3 | 4.0 | |
| WE-HCI 1050 Series | 10.0 | 33.20 | 12.0 | 11.5 × 10.3 | 4.0 | Wurth Elektronik www.we-online.com |
| | 2.4 | 3.50 | 17.0 | 10.6 × 10.6 | 5.0 | |
| | 3.3 | 5.90 | 15.0 | 10.6 × 10.6 | 5.0 | |
| | 4.2 | 7.10 | 14.0 | 10.6 × 10.6 | 5.0 | |
| | 5.5 | 10.30 | 12.0 | 10.6 × 10.6 | 5.0 | |
| | 6.5 | 12.50 | 10.0 | 10.6 × 10.6 | 5.0 | |
| | 7.8 | 13.60 | 9.5 | 10.6 × 10.6 | 5.0 | |
| 10.0 | 16.30 | 8.5 | 10.6 × 10.6 | 5.0 | | |

APPLICATIONS INFORMATION

Checking Transient Response

The OPTI-LOOP external compensation allows the transient response to be optimized for a wide range of loads and output capacitors via the ITH pin. This allows for optimization of the control loop behavior and provides a DC-coupled and AC-filtered closed-loop response test point. The DC step, rise time and settling at this test point truly reflects these closed-loop responses. Assuming a predominantly second order system, phase margin and/or damping factor can be estimated using the percentage of overshoot seen at this pin.

The typical application section provides adequate starting points for different applications. The RC filter sets the dominant pole-zero loop compensation. The values can be modified slightly (from 0.5 to 2 times their suggested value) to optimize transient response once the final PC layout is done and the particular output capacitor type and value have been determined. The output capacitors need to be selected because their various types and values determine the loop feedback factor gain and phase. An output current pulse of 20% to 100% of full load current having a rise time of 1 μ s to 10 μ s will produce output voltage and ITH pin waveforms that will give a sense of the overall loop stability without breaking the feedback loop.

Switching regulators take several cycles to respond to a step in load current. When a load step occurs, V_{OUT^-} immediately shifts by an amount equal to the $\Delta I_{LOAD} \cdot ESR$, where ESR is the effective series resistance of C_{OUT} . ΔI_{LOAD} also begins to charge or discharge C_{OUT} generating a feedback error signal used by the regulator to return V_{OUT^-} to its steady-state value. During this recovery time, V_{OUT^-} can be monitored for overshoot or ringing that would indicate a stability problem.

The initial output voltage step may not be within the bandwidth of the feedback loop, so the standard second order overshoot/DC ratio cannot be used to determine phase margin. The gain of the loop increases with the R_{ITH} and the bandwidth of the loop increases with decreasing C_{ITH} . If

R_{ITH} is increased by the same factor that C_{ITH} is decreased, the zero frequency will be kept the same, thereby keeping the phase the same in most critical frequency ranges of the feedback loop.

The output voltage settling behavior is related to the stability of the closed-loop system and will demonstrate the actual overall supply performance. For a detailed explanation of optimizing the compensation components, including a review of control loop theory, refer to Analog Devices Application Note 76.

Max Output Current

The maximum output current for the LTC7149 is equal to:

$$I_{OUT(MAX)} = 4A \cdot (1 - D_{eff})$$

Such that D_{eff} denotes the effective duty cycle of the application. On the first order,

$$D_{eff} \approx \frac{|V_{OUT^-}|}{V_{IN} + |V_{OUT^-}|}$$

However, voltage drops across the power switches and inductor DCR leads to errors in that approximation.

$$D_{eff} = \frac{|V_{OUT^-}| + 4A \cdot R_L + 4A \cdot R_{BOT}}{V_{IN} + |V_{OUT^-}| - 4A \cdot R_{TOP} + 4A \cdot R_{BOT}}$$

$$D_{eff} = \frac{|V_{OUT^-}| + 4A \cdot R_L + 0.2V}{V_{IN} + |V_{OUT^-}| - 0.24V}$$

Where R_L is the DCR of the inductor.

Refer to Maximum Output Current vs Input Voltage in the typical performance characteristics section for a quick reference.

Output Short Considerations

In an event where the output of the LTC7149 is shorted to GND through a low resistance, high inductance trace/wire, it is likely for the V_{OUT^-} voltage to momentarily spike

APPLICATIONS INFORMATION

above board GND. In a typical application where the GND and V_{OUTSNS} pins are tied directly to the board GND, it would violate the ABSMAX specification of those pins and potentially cause damage to the IC. To prevent damage in this case, connect a 100 Ω resistor between the V_{OUTSNS} pin to board GND, and a 20 Ω resistor between the GND pin to board GND.

Efficiency Considerations

The percent efficiency of a switching regulator is equal to the output power divided by the input power times 100%. It is often useful to analyze individual power losses to determine what is limiting the efficiency and which change would produce the most improvement. Percent efficiency can be expressed as:

$$\% \text{ Efficiency} = 100\% - (P1 + P2 + P3 + \dots)$$

where P1, P2, etc. are the individual losses as a percentage of input power. Although all dissipative elements in the circuit produce losses, three main sources usually account for most of the losses in LTC7149 circuits: 1) I^2R losses, 2) switching and biasing losses, 3) other losses.

1. I^2R losses are calculated from the DC resistances of the internal switches, R_{SW} , and external inductor, R_L . In continuous mode, the average output current flows through inductor L but is “chopped” between the internal top and bottom power MOSFETs. Thus, the series resistance looking into the SW pin is a function of both top and bottom MOSFET $R_{DS(ON)}$ and the duty cycle (D) as follows:

$$R_{SW} = (R_{DS(ON)TOP})(D) + (R_{DS(ON)BOT})(1 - D)$$

The $R_{DS(ON)}$ for both the top and bottom MOSFETs can be obtained from the Typical Performance Characteristics curves. Thus to obtain I^2R losses:

$$I^2R \text{ losses} = I_{OUT}^2(R_{SW} + R_L)$$

2. The switching current is the sum of the MOSFET driver and control currents. The power MOSFET driver current results from switching the gate capacitance of the power MOSFETs. Each time a power MOSFET gate is switched from low to high to low again, a packet of charge dQ moves from V_{IN} to ground. The resulting dQ/dt is a current out of V_{IN} that is typically much larger than the DC control bias current. In continuous mode:

$$I_{GATECHG} = f(Q_T + Q_B)$$

where Q_T and Q_B are the gate charges of the internal top and bottom power MOSFETs and f is the switching frequency. The power loss is thus:

$$\text{Switching Loss} = I_{GATECHG} \cdot V_{IN}$$

The gate charge loss is a function of current through the $INTV_{CC}$ pin as well as frequency. Thus, their effects will be more pronounced in application with high LDO supply voltages (either $EXTV_{CC}$ or V_{IN}) and higher frequencies.

3. Other “hidden” losses such as transition loss and copper trace and internal load resistances can account for additional efficiency degradations in the overall power system. It is very important to include these “system” level losses in the design of a system. Transition loss arises from the brief amount of time the top power MOSFET spends in the saturated region during switch node transitions. The LTC7149 internal power devices switch quickly enough that these losses are not significant compared to other sources. Other losses including diode conduction losses during dead-time and inductor core losses which generally account for less than 2% total additional loss.

APPLICATIONS INFORMATION

Thermal Conditions

In a majority of applications, the LTC7149 does not dissipate much heat due to its high efficiency and low thermal resistance of its exposed-back QFN and FE packages. However, in applications where the LTC7149 is running at high ambient temperature, high V_{IN} , high switching frequency, and maximum output current load, the heat dissipated may exceed the maximum junction temperature of the part. If the junction temperature reaches approximately 180°C, both power switches will be turned off until the temperature drops by 15°C.

To avoid the LTC7149 from exceeding the maximum junction temperature, some thermal analysis must be done. The goal of the thermal analysis is to determine whether the power dissipated exceeds the maximum junction temperature of the part. The temperature rise is given by:

$$T_{RISE} = P_D \cdot \theta_{JA}$$

As an example, consider the case when the LTC7149 is used in applications where $V_{IN} = 24V$, $V_{OUT^-} = -5V$, $I_{OUT} = 4A$ and $f = 1MHz$. The equivalent power MOSFET resistance R_{SW} is:

$$\begin{aligned} R_{SW} &= R_{DS(ON)TOP} \cdot \frac{|V_{OUT^-}|}{V_{IN} + |V_{OUT^-}|} \\ &+ R_{DS(ON)BOT} \cdot \left(1 - \frac{|V_{OUT^-}|}{V_{IN} + |V_{OUT^-}|} \right) \\ &= 110m\Omega \cdot \frac{5V}{29V} + 50m\Omega \cdot \left(1 - \frac{5V}{29V} \right) \\ &= 60.3m\Omega \end{aligned}$$

In the case where the $EXTV_{CC}$ pin is connected to the GND, the V_{IN} current will be minimal as most of the current used to bias up internal circuitry and gate drive will come directly from $EXTV_{CC}$. Typically for a 1MHz application, the current drawn from $EXTV_{CC}$ will be 20mA.

Therefore, the total power dissipated by the part is:

$$\begin{aligned} P_D &= I_{OUT}^2 \cdot R_{SW} + V_{EXTVCC} \cdot I_{EXTVCC} \\ &= 16A^2 \cdot 60.3m\Omega + 5V \cdot 20mA \\ &= 1.07W \end{aligned}$$

The FE28 package junction-to-ambient thermal resistance, θ_{JA} , is around 30°C/W. Therefore, the junction temperature of the regulator operating in a 25°C ambient temperature is approximately:

$$T_J = 1.07W \cdot 30^\circ C/W + 25^\circ C = 57^\circ C$$

Remembering that the above junction temperature is obtained from an $R_{DS(ON)}$ at 25°C, we might recalculate the junction temperature based on a higher $R_{DS(ON)}$ since it increases with temperature. Redoing the calculation assuming that R_{SW} increased 10% at 57°C yields a new junction temperature of 63°C. If the application calls for a higher ambient temperature and/or higher switching frequency, care should be taken to reduce the temperature rise of the part by using a heat sink or air flow.

Board Layout Considerations

When laying out the printed circuit board, the following checklist should be used to ensure proper operation of the LTC7149 (refer to Figure 1). Check the following in your layout:

1. Do the capacitors C_{IN} connect to the V_{IN} and V_{OUT^-} as close as possible? These capacitors provide the AC current to the internal power MOSFETs and their drivers.
2. Are C_{OUT} and L closely connected? The (+) plate of C_{OUT} returns current to GND and the (-) plate of C_{IN} .
3. Solder the exposed pad (Pin 29) on the bottom of the package to the SV_{OUT^-} plane. Connect this SV_{OUT^-} plane to other layers with thermal vias to help dissipate heat from the LTC7149.
4. The ground terminal of the ISET resistor must be connected to the other quiet signal SV_{OUT^-} and together connected to the power V_{OUT^-} on only one point. The ISET resistor should be placed and routed away from noisy components and traces, such as the SW line, and its trace should be minimized.

APPLICATIONS INFORMATION

- Keep sensitive components away from the SW pin. The ISET resistor, R_T resistor, the compensation components C_{ITH} and R_{ITH} , and the $INTV_{CC}$ bypass caps should be routed away from the SW trace and the inductor.
- A ground plane is preferred.
- Flood all unused areas on all layers with copper, which reduces the temperature rise of power components. These copper areas should be connected to GND.

Design Example

As a design example, consider the LTC7149 in an application with the following specifications:

$$V_{IN} = 24V \text{ to } 36V$$

$$V_{OUT} = -5V$$

$$I_{OUT(MAX)} = 3A$$

$$I_{OUT(MIN)} = 500mA$$

$$f_{SW} = 1MHz$$

First, the R_{SET} is selected based on:

$$R_{SET} = \frac{V_{OUT}}{50\mu A} = \frac{5V}{50\mu A} = 100k\Omega$$

For best accuracy, a 0.1% 100k resistor is selected.

For a typical soft-start time of 2ms (0% to 90% of final V_{OUT} value), the C_{SET} should be:

$$\begin{aligned} 2ms &= 2.3 \cdot R_{SET} \cdot C_{SET} \\ \Rightarrow C_{SET} &= 8.7nF \end{aligned}$$

A typical 10nF capacitor can be used for C_{SET} .

Because efficiency is important at both high and low load current, Burst Mode operation will be utilized. Select from the characteristic curves the correct R_T resistor for the 1MHz switching frequency. Based on that, R_T should be 100k. Then calculate the inductor value to achieve a current ripple that is about 40% of the maximum load current at maximum V_{IN} :

$$L = \left(\frac{36V}{1MHz \cdot 2.4A} \right) \left(\frac{5V}{41V} \right) = 1.8\mu H$$

C_{OUT} will be selected based on the ESR that is required to satisfy the output ripple requirement and the bulk capacitance needed for loop stability. For this design, two 47 μ F ceramic capacitors will be used.

C_{IN} should be sized for a maximum current rating of:

$$I_{RMS} = 3A \sqrt{\frac{5V}{24V}} = 1.37A$$

Decoupling the V_{IN} pin with one 22 μ F ceramic capacitor is adequate for most applications.

TYPICAL APPLICATIONS

12V Input to -5V Output at 1MHz Operation

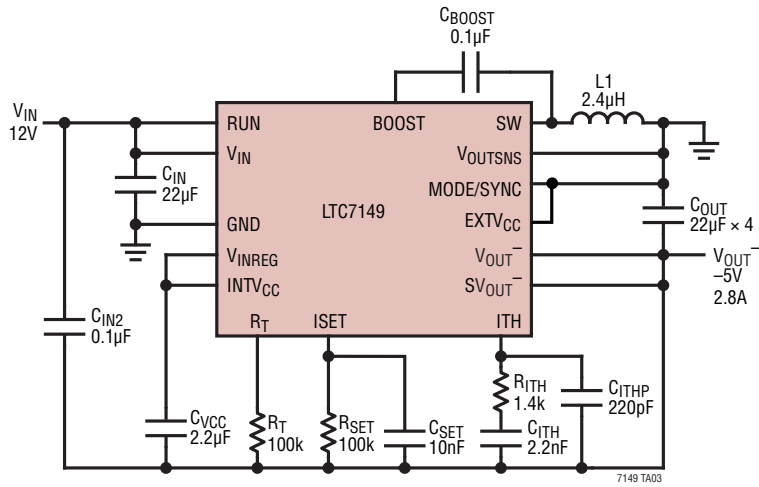

Transient Response

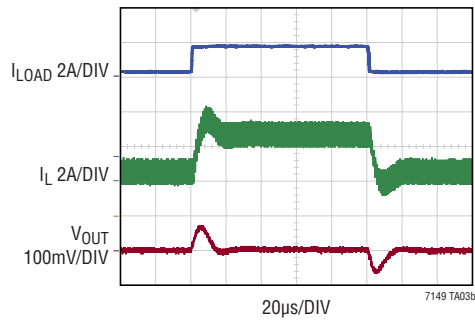

TYPICAL APPLICATIONS

12V Input to -12V Output at 1MHz Operation

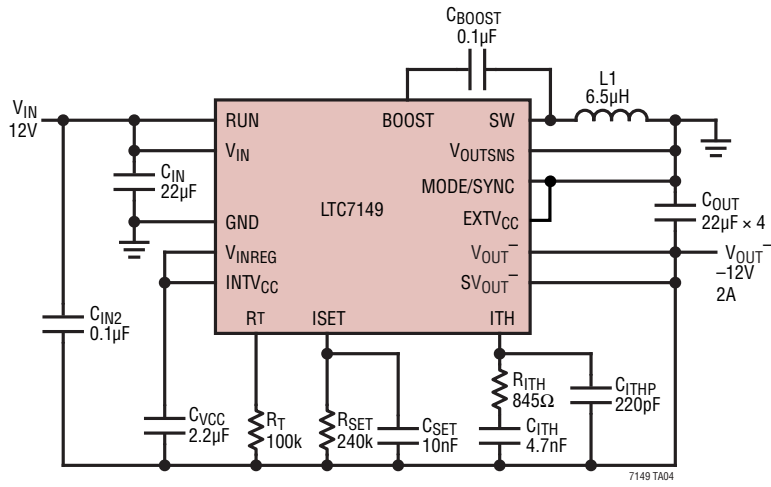

Transient Response

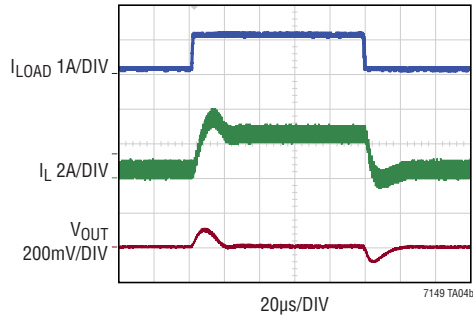

TYPICAL APPLICATIONS

24V Input to -5V Output at 1MHz Operation

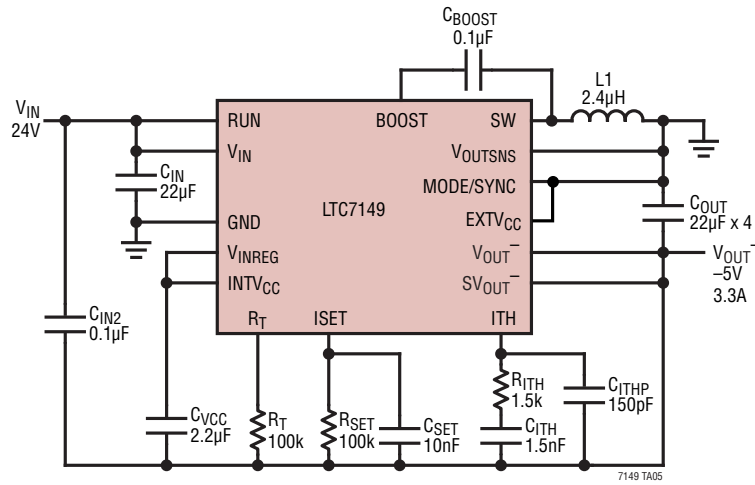

Transient Response

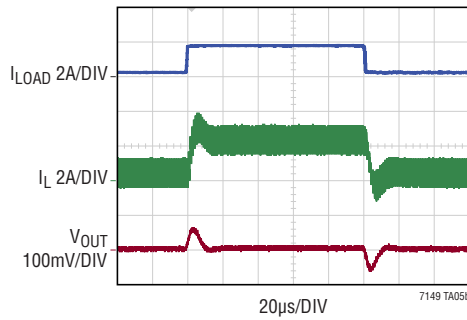

TYPICAL APPLICATIONS

24V Input to -12V Output at 1MHz Operation

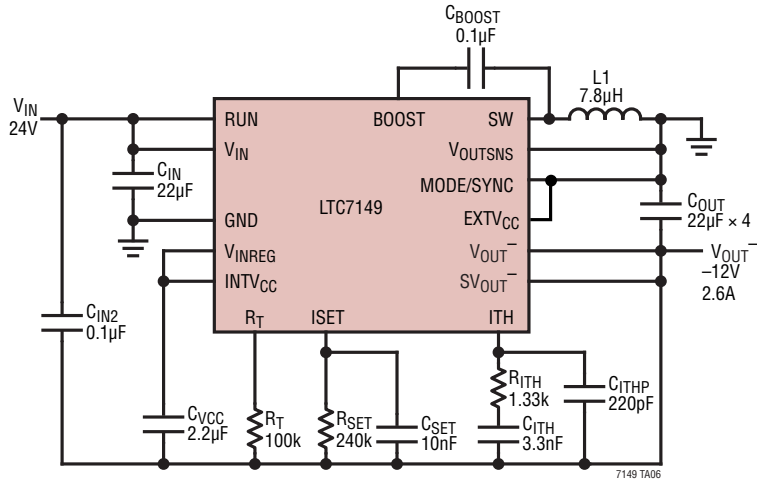

Transient Response

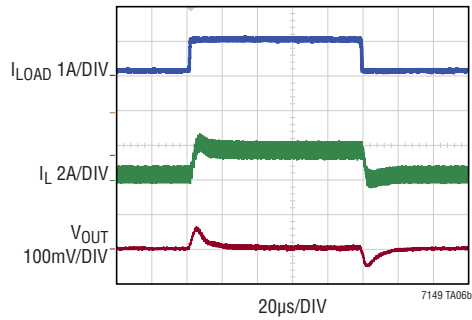

TYPICAL APPLICATIONS

24V Input to -24V Output at 1MHz Operation

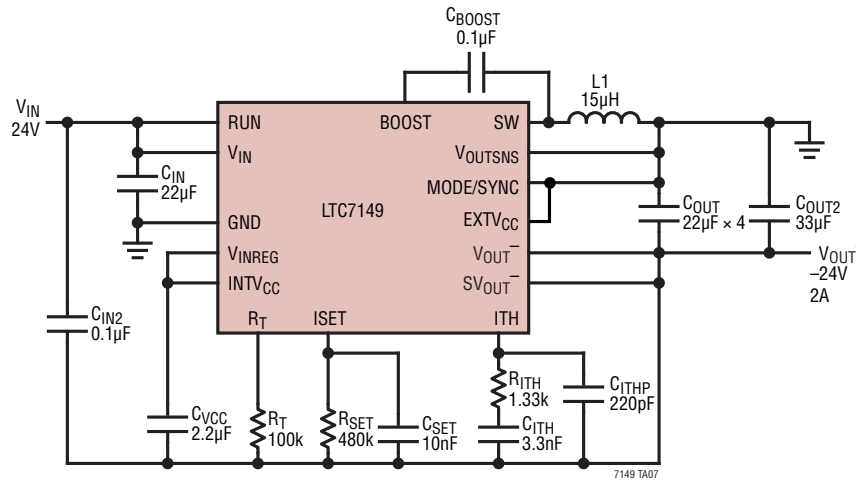

Transient Response

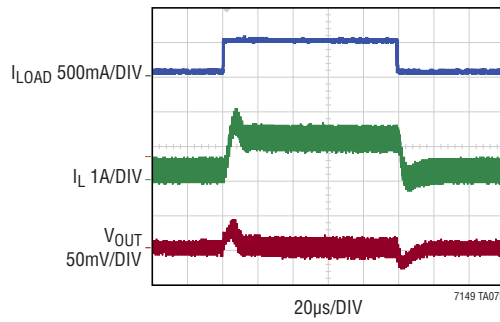

PACKAGE DESCRIPTION

Please refer to <http://www.linear.com/product/LTC7149#packaging> for the most recent package drawings.

UFD Package
28-Lead Plastic QFN (4mm × 5mm)
 (Reference LTC DWG # 05-08-1712 Rev C)

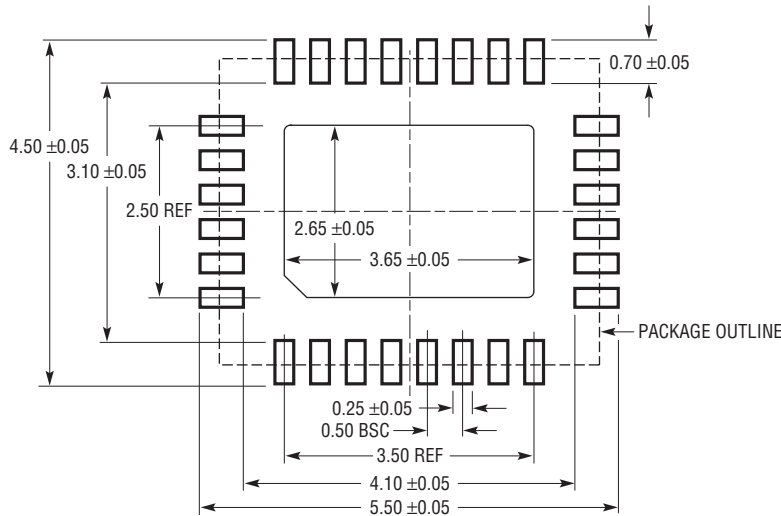

RECOMMENDED SOLDER PAD PITCH AND DIMENSIONS
 APPLY SOLDER MASK TO AREAS THAT ARE NOT SOLDERED

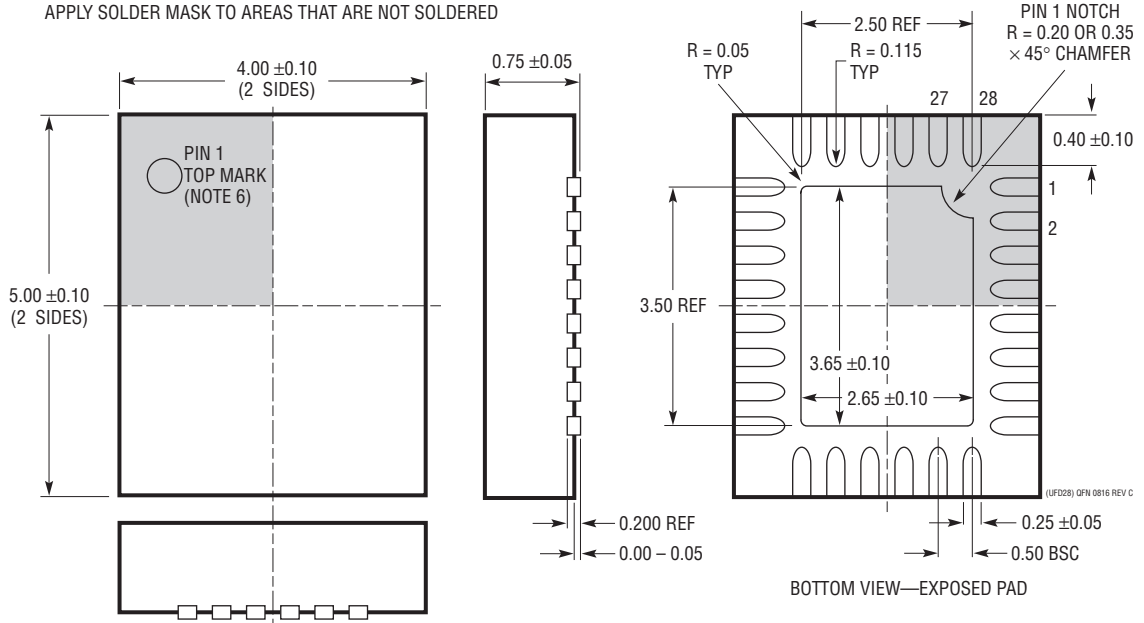

- NOTE:
1. DRAWING PROPOSED TO BE MADE A JEDEC PACKAGE OUTLINE MO-220 VARIATION (WGHD-3).
 2. DRAWING NOT TO SCALE
 3. ALL DIMENSIONS ARE IN MILLIMETERS
 4. DIMENSIONS OF EXPOSED PAD ON BOTTOM OF PACKAGE DO NOT INCLUDE MOLD FLASH. MOLD FLASH, IF PRESENT, SHALL NOT EXCEED 0.15mm ON ANY SIDE
 5. EXPOSED PAD SHALL BE SOLDER PLATED
 6. SHADED AREA IS ONLY A REFERENCE FOR PIN 1 LOCATION ON THE TOP AND BOTTOM OF PACKAGE

PACKAGE DESCRIPTION

Please refer to <http://www.linear.com/product/LTC7149#packaging> for the most recent package drawings.

FE Package
28-Lead Plastic TSSOP (4.4mm)
 (Reference LTC DWG # 05-08-1663 Rev L)
Exposed Pad Variation EB

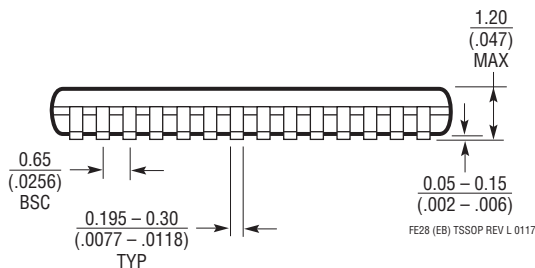
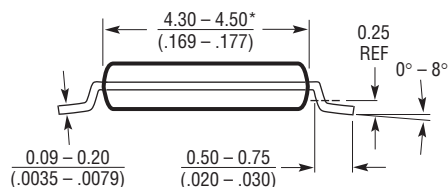
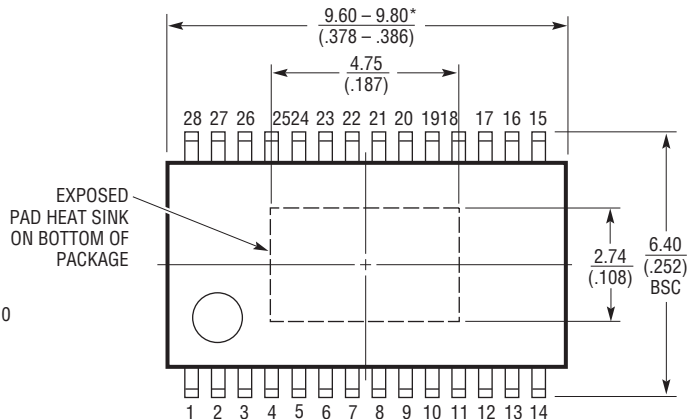
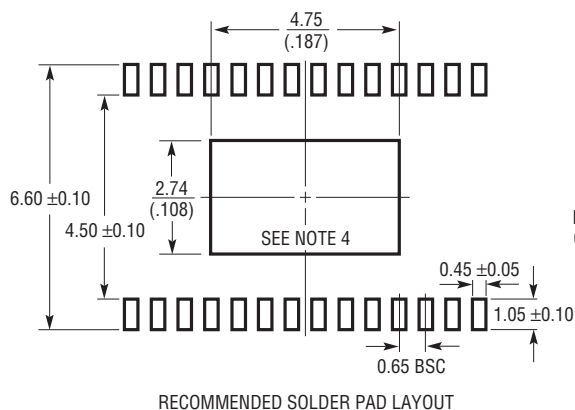

- NOTE:
1. CONTROLLING DIMENSION: MILLIMETERS
 2. DIMENSIONS ARE IN MILLIMETERS (INCHES)
 3. DRAWING NOT TO SCALE
 4. RECOMMENDED MINIMUM PCB METAL SIZE FOR EXPOSED PAD ATTACHMENT
- *DIMENSIONS DO NOT INCLUDE MOLD FLASH. MOLD FLASH SHALL NOT EXCEED 0.150mm (.006") PER SIDE

REVISION HISTORY

| REV | DATE | DESCRIPTION | PAGE NUMBER |
|-----|-------|---|--------------|
| A | 03/18 | Clarified Absolute Maximum Ratings Clarified Functional Diagram Clarified Board Layout Considerations | 2 8 17 |

TYPICAL APPLICATION

24V Input Concurrent ±12V Supply

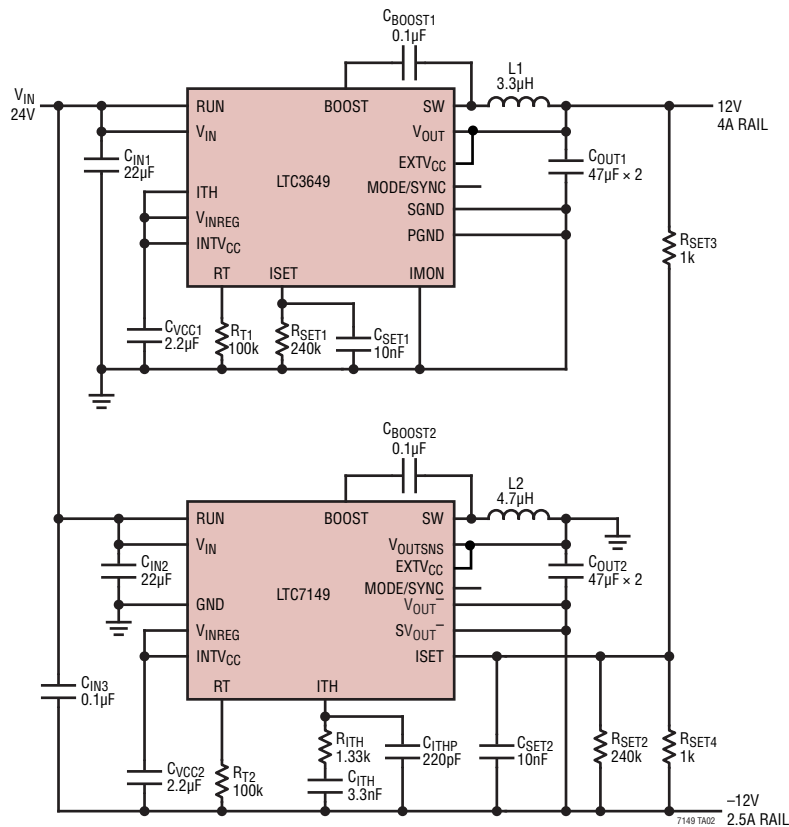

RELATED PARTS

| PART NUMBER | DESCRIPTION | COMMENTS |
|-----------------------|---|--|
| LTC3649 | 60V, 4A Synchronous Rail-to-Rail Single Resistor Step-Down Regulator | V _{IN(MIN)} = 3.1V, V _{IN(MAX)} = 60V, V _{OUT(MIN)} = 0V, 4mm × 5mm QFN-28, TSSOP-28E |
| LTC3600 | 15V, 1.5A Synchronous Rail-to-Rail Single Resistor Step-Down Regulator | V _{IN(MIN)} = 4V, V _{IN(MAX)} = 15V, V _{OUT(MIN)} = 0V, MSOP-12, 3mm × 3mm DFN-12 |
| LTC3892/ LTC3892-1 | 60V, Low I _Q , Dual 2-Phase Synchronous Step-Down DC/DC Controller with 99% Duty Cycle | PLL Fixed Frequency 50kHz to 900kHz, 4.5V ≤ V _{IN} ≤ 60V, 0.8V ≤ V _{OUT} ≤ 0.99V _{IN} , I _Q = 29μA |
| LTC3891 | 60V, Low I _Q , Synchronous Step-Down DC/DC Controller with 99% Duty Cycle | PLL Fixed Frequency 50kHz to 900kHz, 4V ≤ V _{IN} ≤ 60V, 0.8V ≤ V _{OUT} ≤ 24V, I _Q = 50μA |
| LT [®] 8620 | 65V, 2.5A, 96% Efficiency, 2.2MHz Synchronous Micropower Step-Down DC/DC Converter with I _Q = 2.5μA | V _{IN(MIN)} = 3.4V, V _{IN(MAX)} = 65V, V _{OUT(MIN)} = 0.97V, I _Q = 2.5μA, I _{SD} < 1μA, MSOP-16E 3mm × 5mm QFN-24 |
| LTC3863 | 60V, Low I _Q Inverting DC/DC Controller | V _{IN(MIN)} = 3.5V, V _{IN(MAX)} = 60V, V _{OUT(MIN)} = -150V, 3mm × 4mm DFN-12, MSOP-12E |
| LT8611 | 42V, 2.5A, 96% Efficiency, 2.2MHz Synchronous Micropower Step-Down DC/DC Converter with I _Q = 2.5μA and Input/Output Current Limit/Monitor | V _{IN(MIN)} = 3.4V, V _{IN(MAX)} = 42V, V _{OUT(MIN)} = 0.97V, I _Q = 2.5μA, I _{SD} < 1μA, 3mm × 5mm QFN-24 |
| LT8612 | 42V, 6A, 96% Efficiency, 2.2MHz Synchronous Micropower Step-Down DC/DC Converter with I _Q = 2.5μA | V _{IN(MIN)} = 3.4V, V _{IN(MAX)} = 42V, V _{OUT(MIN)} = 0.97V, I _Q = 3.0μA, I _{SD} < 1μA, 3mm × 6mm QFN-28 |
| LT8614 | 42V, 4A, 96% Efficiency, 2.2MHz Synchronous Micropower Step-Down DC/DC Converter with I _Q = 2.5μA | V _{IN(MIN)} = 3.4V, V _{IN(MAX)} = 42V, V _{OUT(MIN)} = 0.97V, I _Q = 2.5μA, I _{SD} < 1μA, 3mm × 4mm QFN-18 |

7149fa