

QUICK START GUIDE FOR DEMONSTRATION CIRCUIT 596

EVALUATION CARD FOR THE LT1813 IN THE DFN PACKAGE

LT1813CDD

DESCRIPTION

Demonstration circuit 596 simplifies the evaluation of the LT1813CDD op amp in the tiny, 3mm × 3mm, DFN (Dual in-line, Flat, No-leads) chip-scale package. Electrical performance of this LT1813 is the same as previous versions. This version is only a packaging enhancement.

An evaluation circuit can easily be built on this board without handling the tiny DFN device. Pads are provided for adding external components and holes are available for jumpers, signal I/O and supply wires. Supply bypass capacitors are already on the board. Alternatively adding two 4-pin headers (0.1" spacing) converts the board to a standard 8-pin DIP format for use with a socket on a second circuit board.

The backside of this evaluation board is void of metal to allow wiring into an existing system with the board resting on top of other components.

About the LT1813CDD

The LT1813 is a Dual, Low Power, High Speed, Voltage Feedback Amplifier

- 100MHz Gain Bandwidth Product
- 750V/μsec Slew Rate
- 3.6mA Supply Current per Amplifier, 100mA Output Current
- 25V/μsec Slew Rate
- 30nsec Settling Time to 0.1%
- Total Supply Voltage Range: 4V to 12V

Table 1. Typical Performance Summary (±5V Supply, T_a=25°C) Visit www.linear.com for complete data sheet.

PARAMETER	CONDITION	VALUE
Supply Current	Per Amplifier	3mA
Offset Voltage		500μV
Input Bias Current		0.9μA
Rise and Fall Time	A _v =1, R _L =100Ω	2nsec
Gain Bandwidth Product		100MHz
Slew Rate		750 V/μsec

Device Top Mark Identifier: LAAQ

QUICK START PROCEDURE

Build the evaluation circuit in one of two ways as shown in Figures 1 and 2.

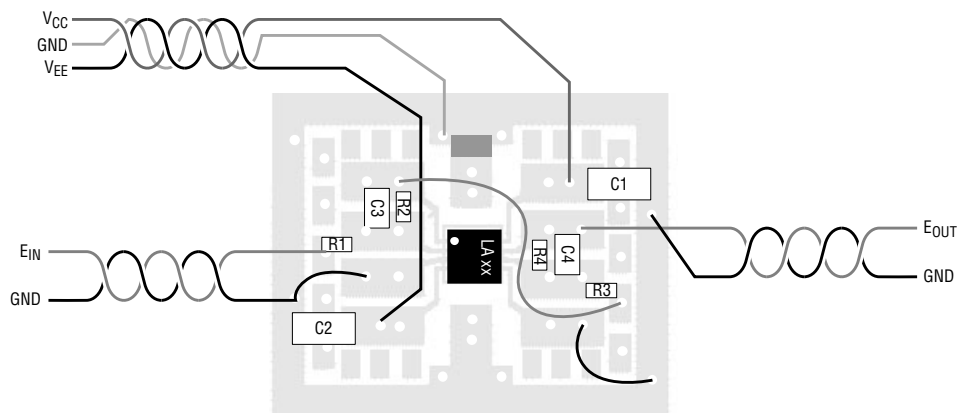

Figure 1. External Components Directly on the PCB (0.1 μ F Bypass Capacitors: AVX 1206C104KAT). Example connections shown may not be correct for this device.

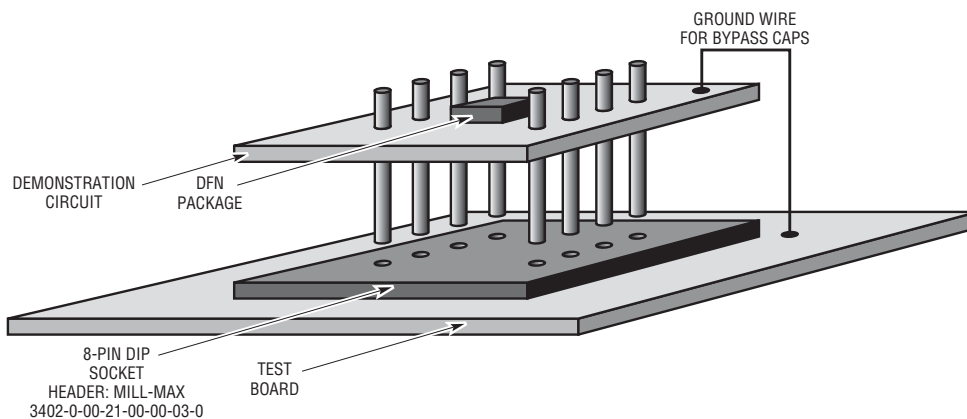
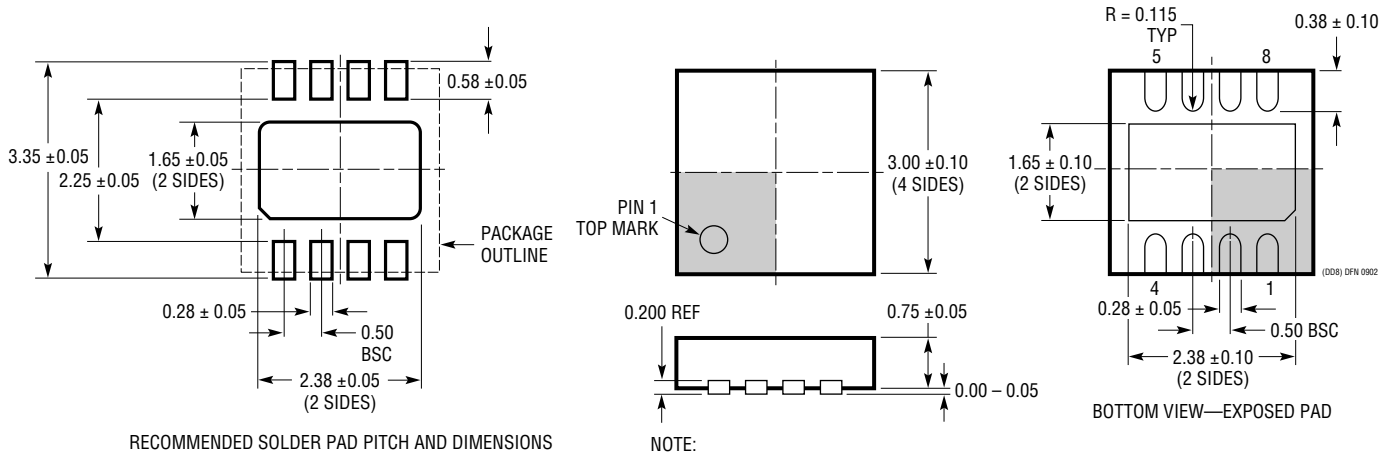

Figure 2. Convert the Board to an 8-pin DIP Format

PACKAGE AND CONNECTION DRAWING



NOTE:

1. DRAWING TO BE MADE A JEDEC PACKAGE OUTLINE M0-229 VARIATION OF (WEED-1)
2. ALL DIMENSIONS ARE IN MILLIMETERS
3. DIMENSIONS OF EXPOSED PAD ON BOTTOM OF PACKAGE DO NOT INCLUDE MOLD FLASH. MOLD FLASH, IF PRESENT, SHALL NOT EXCEED 0.15mm ON ANY SIDE
4. EXPOSED PAD SHALL BE SOLDER PLATED

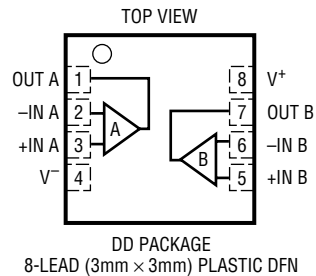

ASSEMBLY TIPS

Following are the recommended procedures for soldering surface mount packages to PC boards.

☐ Reflow Soldering with Solder Paste

- Use of solder plated boards is recommended.
- Screen solder paste on board.
- Mount components on board.
- Infrared or forced hot air convection reflow is recommended for best performance. Parameters:
 - Preheat peak temperature $125^{\circ}\text{C} \pm 15^{\circ}\text{C}$ and 2°C to 4°C per second rise

- Activation temperature 130°C to 150°C
- Reflow begins at 183°C (63Sn/37Pb)
- Time above 183°C for 30 seconds
- Peak package body temperature 220°C to 245°C
- Dwell time at peak temperature 10 seconds max
- Cooling rate 2°C to 4°C per second
- Clean boards.
- For Vapor Phase Reflow, recommended parameter ranges for:
 - Heating rate: 4°C per second max

QUICK START GUIDE FOR DEMONSTRATION CIRCUIT 596

EVALUATION CARD FOR THE LT1813 IN THE DFN PACKAGE

- Preheat temperature: 45°C to 80°C
- Time above 200°C: 50 seconds to 90 seconds
- Peak package temperature: 212°C to 219°C

Wave Soldering and Hand Soldering are not recommended.

REWORK GUIDELINES FOR DFN PACKAGES

Each package mounting site should be reworked one at a time only, to ensure maximum quality and reliability.

Linear Technology has found the following rework procedure to be effective with DFN packages but by no means excludes other methods more suited to specific manufacturing needs.

Reflow Temperature Profile

Each package site to be reworked should be individually heated. The reflow temperature profile can be established using a hot gas tool and a thermocouple embedded in the solder joints of a sample setup unit on the PCB.

Preheating and Package Removal

A package rework tool with vacuum pickup similar to the A.P.E. Flo-Master can be used. A bottom PCB heater is required to provide preheating of the PCB to approximately 110°C to 120°C. The rework nozzle must be centered with respect to the package in order to direct the hot gas flow over the top of the package while limiting the temperature of the adjacent components to prevent solder reflow.

Site Rework

With a combination on hot gas/vacuum desoldering tool and solder wick ribbons (if necessary), remove

the package and any remaining solder residues. Use a minimal amount of flux if it is required to remove solder residue. This will also assist in leaving a smooth, flat surface for the reattachment of a replacement unit. The site for the package should be thoroughly cleaned with isopropyl alcohol (IPA) and dried with clean dry air (CDA).

Solder Paste Application

Solder paste may be screen printed on to the package landing site and exposed heat sink pads. Stainless steel stencils are recommended for solder paste application. The printed solder deposits should be 100 percent inspected for uniformity of size and shape. Some applications may have severe space constraints preventing screen printing to be accomplished on the PCB. Therefore, solder paste can be directly applied to the packages landing site and exposed heatsink pad. The package is to be picked and placed using a vision aided system similar to the A.P.E. Sniper SMD 7007 Rework System.

Reflow Process

The replacement package, once it has been placed onto the reworked PCB landing site, should be reflowed on the PCB using a hot gas tool on the top of the package and a heater on the bottom of the PCB. The reflow temperature should not exceed 240°C. Note that liquidus temperature for 63/37 Sn/Pb solder is 183°C. Make sure to limit adjacent components to below the solder reflow temperature. The solder paste manufacturer's recommended reflow temperature profile/specifications must be complied with to avoid damage to the PCB and/or adjacent components. A 100 percent post rework visual inspection for good joint wetting is recommended.