

Keywords: power regulator control, pulse-frequency modulation, PFM, pulse-width modulation, PWM, hysteretic control, constant on-time control, COT

APPLICATION NOTE 5999

# CHOOSE THE RIGHT REGULATOR FOR THE JOB: PART 2, PRIMARY REGULATOR CONTROL SCHEMES

By: Don Corey, Principal Member of Technical Staff, Maxim Integrated

*Abstract: This application note is Part 2 of a 3-part series on power regulators and discusses primary regulator control schemes: pulse-frequency modulation (PFM), hysteretic, and constant on-time topologies (COT). A short discussion follows about secondary control such as skip mode.*

## Overview

**Part 1:** Brief review of the importance of duty cycle and load usage. The main focus is regulator control schemes, their types, critical parameters, and compensation schemes. We will finish with a short description of internal versus external FET's.

**Part 2:** Other topologies besides voltage mode (VM) and current mode (CM) control that incorporate constant on-time, hysteretic, and pulse-frequency modulation (PFM) topologies. Also explains how to select these regulator types for an application.

**Part 3:** closes with how to select and simulate the optimal regulator for an application.

## Introduction

One size does not fit all! Quite the opposite. Semiconductor companies target segment markets and tailor regulator parameters to the end-product requirements. Clearly, understanding the application will help dictate the right choice of regulator.

In [Choose the Right Regulator for the Job: Part 1](#), we discussed two regulator control schemes, current mode (CM) and voltage mode (VM), for pulse-width modulated (PWM) converters. We also examined the critical differences between those control modes. In that application note, we explained how the product application is very important for selecting the right regulator.

In Part 2 we examine other commonly used regulator control topologies and describe the application benefits for each. Besides the VM and CM PWM control, modern regulators incorporate other primary control schemes: pulse-frequency modulation (PFM), hysteretic, and constant on-time topologies (COT). After we look at each, we add a short discussion about secondary control methods, such as skip mode.

Later, [Part 3](#) provides basic equations to help a designer choose the best regulator for an application and optimize the surrounding components.

## A PFM Converter Provides Better Overall Efficiency

A PFM converter<sup>1</sup> is an alternative DC-DC architecture. This control scheme varies the converter switching frequency in direct relationship to the converter load. Consequently, the architecture is referred to as PFM. Many portable applications will use PFM mode to maximize battery life, because a PFM converter is much more efficient at light loads than a PWM-based converter.

Electromagnetic interference (EMI) is an important consideration when choosing between a PWM or PFM converter. In PWM mode, the switching frequency is fixed so EMI from converter switching is predictable and constant, and in many cases can be filtered. Many PWM converters also offer external, frequency synchronization input to help mitigate conflict with other important signal frequencies often present on the application board. If an application requires more than one voltage, all the switching converters can be clocked at the same frequency. This approach eliminates the inherent beat frequencies when multiple converters are not switching at the same frequency and not perfectly phase aligned. In contrast to PWM topologies, the switching frequency is variable for PFM, and it is much harder to control EMI. As such, PFM mode may not be the best choice for powering sensitive audio or RF low-noise circuits. PFM would, however, be an excellent choice when efficiency must be optimized over a wide range of output loads.

It should be noted, finally, that many converters have provisions to run in either PFM or PWM mode. A logic-controlled mode pin or internal circuitry automatically switches between these two modes based on load current.

## Operation of a PFM Controller

In step-up PFM control<sup>1</sup> two one-shot circuits operate based on the load current from the DC-DC converter's output. The PFM is based on two switching times (the maximum on-time and the minimum off-time) and two control loops (a voltage-regulation loop and a maximum peak-current, off-time loop). The PFM is also characterized by control pulses of variable frequency. The two one-shot circuits in the controller define the  $T_{ON}$  (maximum on-time) and the  $T_{OFF}$  (minimum off-time). The  $T_{ON}$  one-shot circuit activates the second one-shot,

$T_{OFF}$ . Whenever the comparator of the voltage loop detects that  $V_{OUT}$  is out of regulation, the  $T_{ON}$  one-shot circuit is activated. The time of the pulse is fixed up to a maximum value. This pulse time can be reduced if the maximum peak-current loop detects that the current limit is surpassed, as shown in **Figure 1**. The quiescent current ( $I_Q$ ) consumption of a PFM controller is limited only to the current needed to bias its reference and error comparator (10s of  $\mu A$ ). In striking contrast, the internal oscillator of a PWM controller must be turned on continuously, leading to a current consumption of several milliamps.

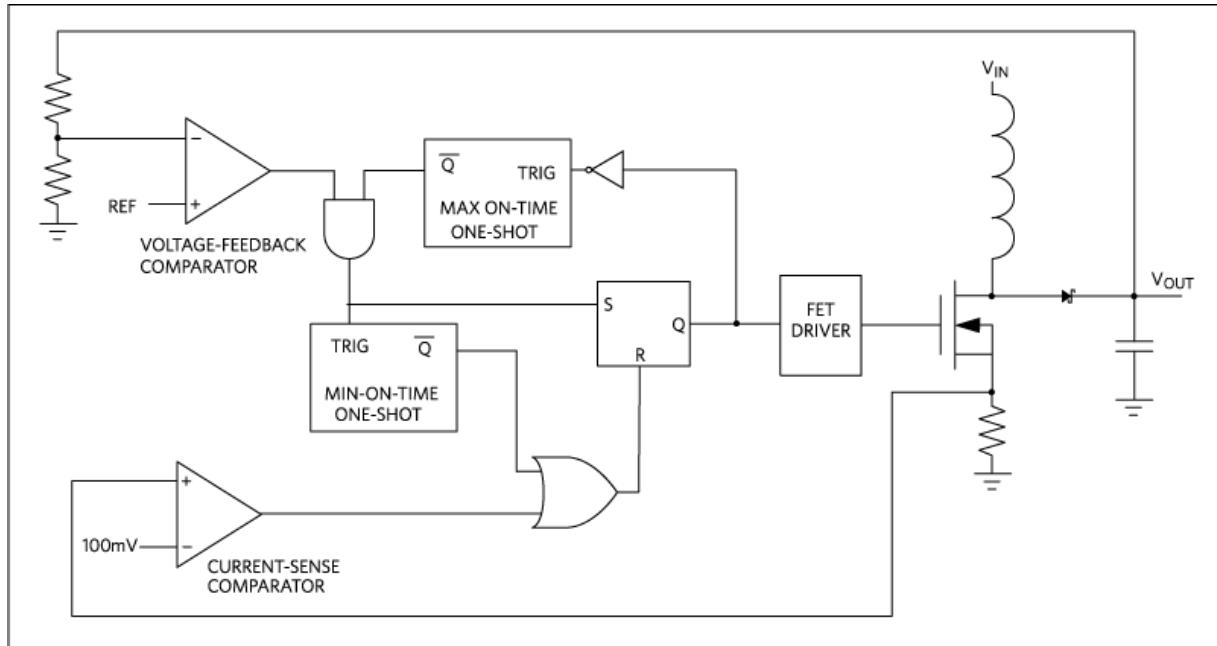

Figure 1. Pulse-frequency modulation (PFM) control circuit. With this topology the pulse time can be reduced if the maximum peak-current loop detects that the current limit is surpassed.

Synchronous step-down converters have dual-mode operation so the designer can select between PWM and PFM modes and optimize efficiency over a wide range of load currents. Two example converters, the [MAX17503](#) and [MAX17504](#), use an alternate PFM control scheme but are also good examples for efficiency improvement at lighter loads. For example, **Figure 2** shows efficiency curves for PFM and PWM modes. With load currents below 100mA in PFM mode we see a dramatic efficiency improvement versus PWM mode for the same load current. Note that for a voltage input of 12V and voltage output of +5V, the efficiency is close to 92% in PFM mode versus 81% in PWM mode!

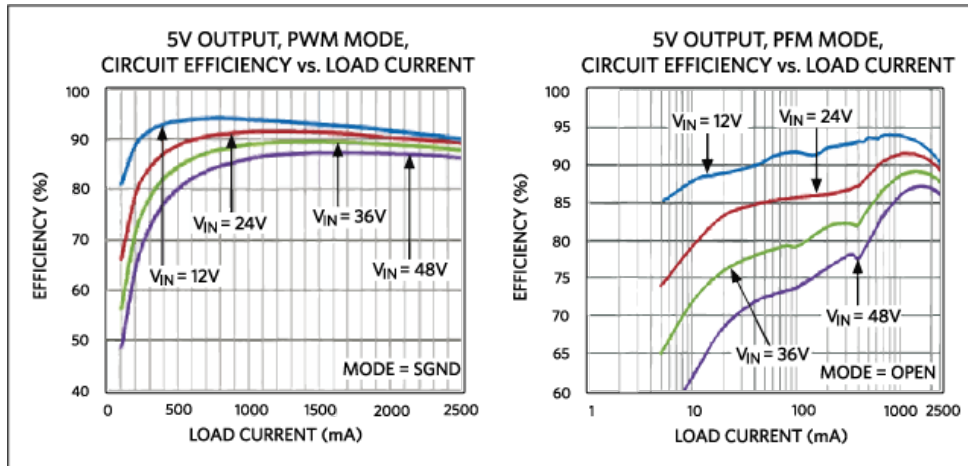

Figure 2. PWM and PFM efficiency curves for the MAX17503 step-down converter. Note that with load currents below 100mA in PFM mode (right) there is a dramatic efficiency improvement vs. PWM mode for the same load current.

Let's summarize the advantages of PFM:

- Very good low-power conversion efficiency
- Does not require a loop-compensation network
- Lower solution cost

And the PFM disadvantages:

- Variable frequency can be harder to filter for emissions. This mode may not be suitable in the presence of low-noise, sensitive analog circuitry.
- Output ripple can be higher than PWM mode.

### A Hysteretic Converter Offers Predictable Operation

As in most comparator-based circuits, hysteresis is used to maintain predictable operation and avoid switch chatter. The hysteretic converter<sup>2</sup> in **Figure 3** turns the power FET on or off based on the output voltage changes sensed by the converter. Sometimes called a "ripple regulator" or "bang-bang controller," this architecture continuously shuttles the output voltage back and forth to just above or below the ideal set point. Because the hysteretic architecture varies, the drive signal to the power FET is based on the operating conditions of the circuit. The switching frequency is not constant. The hysteretic approach is, therefore, one type of PFM architecture.

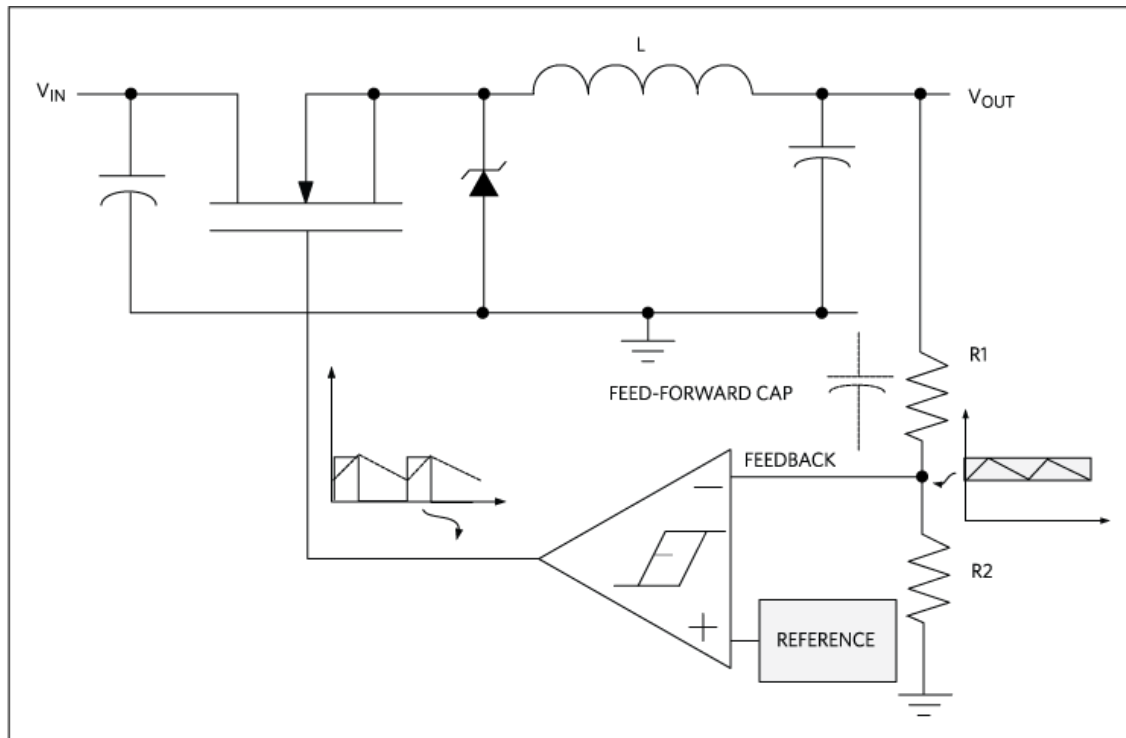

Figure 3. Hysteretic control converter turns the power FET on or off based on the output voltage changes sensed by the converter.

Now look at the advantages of hysteretic control:

- No loop compensation required (the same for a PFM topology). The loop bandwidth is close to the switching frequency itself.
- No clock or error amplifier is needed, so operating current is very low. This type of regulator is suitable for battery-powered applications.
- Hysteretic converters are low cost.

And the hysteretic control disadvantages:

- With no fixed clock, it is difficult to predict switching frequency compared to PWM control. This type of regulator is not suitable for applications with sensitive analog circuitry.
- May require a feed-forward capacitor across R1 in Figure 3 to increase voltage ripple on the feedback pin when using lower-ESR output capacitors.

### Hysteretic Constant On-Time (COT) Control Keeps Frequencies Constant

Recall that the main disadvantage of the hysteretic converter is the variable frequency. Because it uses a comparator with hysteresis, there must be sufficient voltage ripple at the feedback node to ensure stable switching. Basically, the ripple voltage at the comparator's feedback node must be greater than the comparator's hysteresis band. Moreover, a higher ESR capacitor may be needed to increase output ripple voltage or a feed-forward capacitor like the one in Figure 3 must be added. To keep the frequency as constant as possible, a constant on-time (COT) generator has been added. In this COT control mode, the  $T_{ON}$  time will be inversely proportional to the input voltage, as shown in Figure 4.

The COT generator greatly enhances this type of converter, allowing it to maintain a constant frequency over a wider range of input voltages. The generator, however, does not solve the need to add ripple at the feedback node to help the comparator switch. The addition of COT to hysteretic control lets the design engineer better predict the switching frequency. COT control also lets you better optimize filtering for EMI and offers the advantage of low cost and good transient response. Modern converters with COT control also create a ripple voltage by sensing the current in the low-side MOSFET. The COT control then adds this voltage to the internal feedback voltage or to the internal voltage reference. The resulting benefits from the COT control technology are important: no more requirements for a ripple voltage and low-ESR ceramic capacitors can now be used.

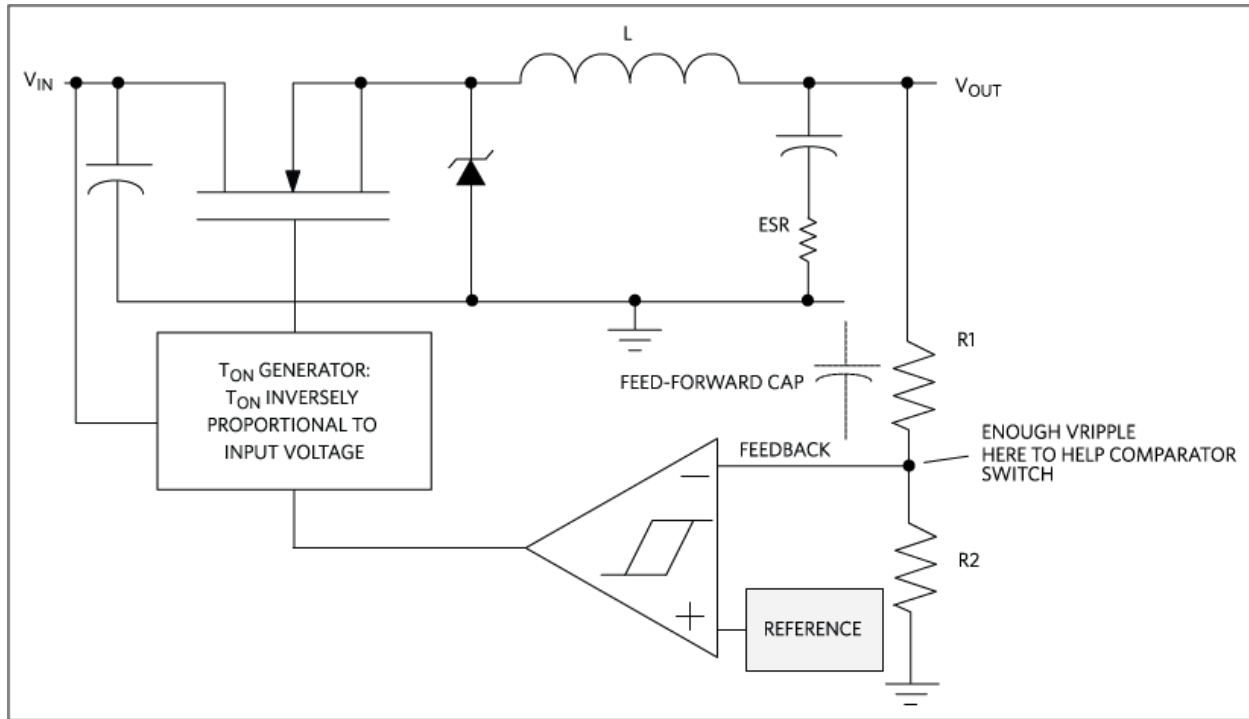

Figure 4. Constant on-time (COT) hysteretic converter keeps the frequency as constant as possible.

There are modern synchronous step-down converters that employ a minimum on-time control in a hysteretic PWM control scheme. As in Figure 3, the hysteretic comparator is still used. Operation of this control scheme is quite simple. When the output voltage is below the regulation threshold, the error comparator begins a switching cycle by turning on the high-side switch. This switch remains on until the minimum on-time expires and either the output voltage is above the regulation threshold or the inductor current is above the current-limit threshold. Once off, the high-side switch remains off until the minimum off-time expires and the output voltage again falls below the regulation threshold. During the off period, the low-side synchronous rectifier turns on and remains on until either the high-side switch turns on again or the inductor current approaches zero. To help improve efficiency, an internal synchronous rectifier eliminates the need for an external Schottky diode, as shown in **Figure 5**.

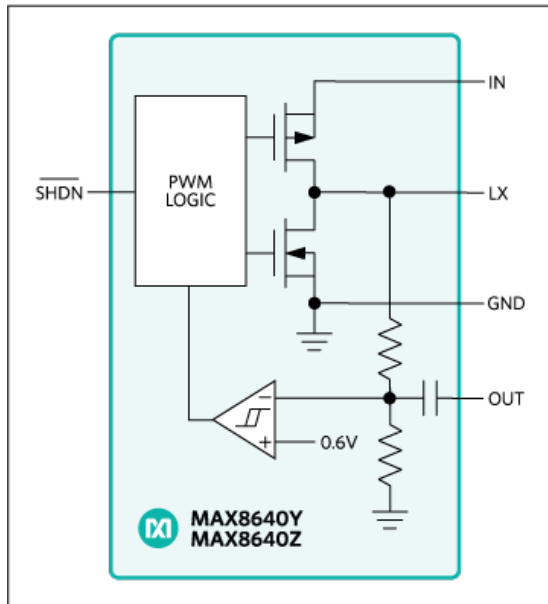

Figure 5. Hysteretic PWM control in the MAX8640Y/MAX8640Z step-down converter.

### Skip/Power-Save Mode Optimizes Efficiency at Lighter Loads

Pulse-skipping, also called power-save, mode is a secondary control mode used with some PWM converter architectures; it is especially useful to optimize efficiency at lighter loads for portable or low-power applications.

When a PWM converter operates at moderate to high load currents, it runs in critical conduction mode, meaning that the inductor current will not reach down to zero. As the load current decreases, the converter may switch to discontinuous conduction mode, where the current in the inductor does decrease to zero, depending on the value of the inductor. Then at very light loads, the converter goes into skip or power-save mode. Now it intermittently turns off the internal oscillator and reenables it only as needed to maintain the output regulation. Hence, the “skipping” and power savings. Because this action further modulates the switching frequency, skip or power-save mode is sometimes referred to as a form of PFM mode.

There are modern DC-DC converters that allow the user to select between PWM or skip mode to reduce current consumption and achieve a higher efficiency at light output loads. In skip mode, the high-side and low-side MOSFETs are turned off when the inductor current falls below the skip-mode current threshold. Thus, the inductor current is never allowed to go negative. If the inductor current falls below this threshold during the off time of the clock cycle, the low-side MOSFET turns off. At the next clock cycle, if the output voltage is above the set point, the PWM logic keeps both high-side and low-side MOSFETs off. If the output voltage is below the set point, the PWM logic turns the high-side MOSFET on for a minimum fixed on-time. This is how cycles are skipped and the switches controlled to service the loads as needed.

The efficiency curves in **Figure 6** show the skip-mode efficiency improvement below 200mA compared to PWM mode of operation under the same conditions.

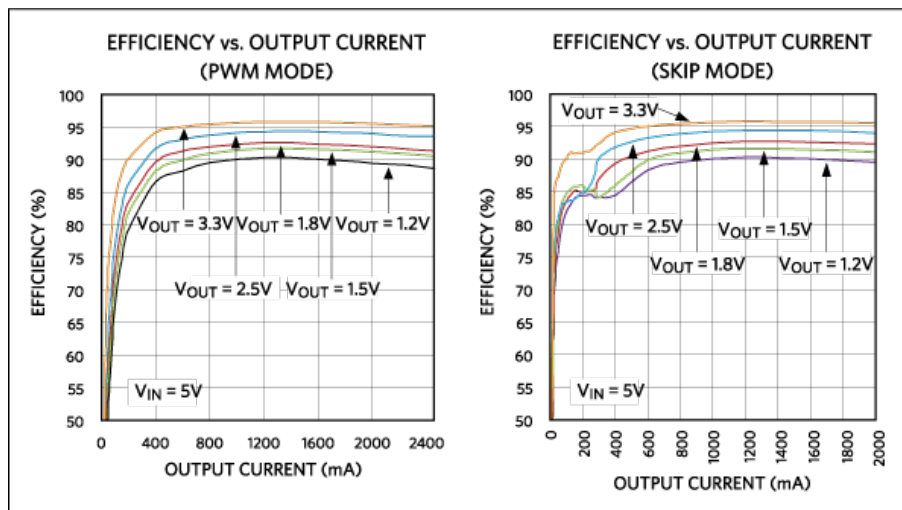

Figure 6. PWM versus skip-mode efficiency curves for the MAX15053 step-down switching regulator. Note the improved efficiency of skip mode below 200mA vs. PWM mode.

## Summary

In this second application note in this series to choose, the right regulator, we discuss, and contrast several control topologies: PFM, hysteric, COT, and skip mode. Despite their various differences, advantages, and disadvantages, we see that these topologies provide a distinct advantage in portable devices where battery runtime and low power must be optimized.

Again, as mentioned in [Part 1](#), there have been countless power-supply articles and text books that examine the topic in great detail. There are also many other control topologies that have been developed and beyond the scope of this application note series. Hopefully the Part 1 and this Part 2 application notes provide a good starting point for engineers wishing to design point-of-load power management. We hope that you will find our final application note on converters interesting.

In the next application note, [Choose the Right Regulator for the Job: Part 3](#), we will provide the basic equations to help a designer choose the best regulator and optimize the surrounding components for the total regulator solution. We will also provide a part selection and simulation example that illustrates the topics discussed in both prior application notes

## References

1. Kägi, Javier Monsalve, Jose Miguel de Diego, Escuela Técnica Superior de Ingeniería, Bilbao, Spain, and Jose Ignacio Garate, Escuela Técnica Superior de Ingeniería, Bilbao, Spain, in Maxim Integrated application note 4326, "Reduce Standby Power Drains with Ultra-Low-Current, Pulse-Frequency-Modulated (PFM) DC-DC Converters," <https://www.maximintegrated.com/en/AN4326>.
2. Upal Sengupta, [PWM and PFM Operation of DC/DC Converters for Portable Applications](http://www.energie-und-technik.de/fileadmin/media/whitepaper/files/PWM_and_PFM_operation_of_DC-DC_converters_for_portable_applications_.pdf), [http://www.energie-und-technik.de/fileadmin/media/whitepaper/files/PWM\\_and\\_PFM\\_operation\\_of\\_DC-DC\\_converters\\_for\\_portable\\_applications\\_.pdf](http://www.energie-und-technik.de/fileadmin/media/whitepaper/files/PWM_and_PFM_operation_of_DC-DC_converters_for_portable_applications_.pdf)

A similar version of this application note appeared February 2015 on [HOW2POWER.com](http://HOW2POWER.com).

Related Parts		
<a href="#">MAX15053</a>	High-Efficiency, 2A, Current-Mode Synchronous, Step-Down Switching Regulator	<a href="#">Free Samples</a>
<a href="#">MAX17503</a>	4.5V-60V, 2.5A, High-Efficiency, Synchronous Step-Down DC-DC Converter with Internal Compensation	<a href="#">Free Samples</a>
<a href="#">MAX17504</a>	4.5V-60V, 3.5A, High-Efficiency, Synchronous Step-Down DC-DC Converter with Internal Compensation	<a href="#">Free Samples</a>
<a href="#">MAX8640Y</a>	Tiny 500mA, 4MHz/2MHz Synchronous Step-Down DC-DC Converters	<a href="#">Free Samples</a>
<a href="#">MAX8640Z</a>	Tiny 500mA, 4MHz/2MHz Synchronous Step-Down DC-DC Converters	<a href="#">Free Samples</a>

---

**More Information**

For Technical Support: <https://www.maximintegrated.com/en/support>

For Samples: <https://www.maximintegrated.com/en/samples>

Other Questions and Comments: <https://www.maximintegrated.com/en/contact>

---

Application Note 5999: <https://www.maximintegrated.com/en/an5999>

APPLICATION NOTE 5999, AN5999, AN 5999, APP5999, Appnote5999, Appnote 5999

© 2014 Maxim Integrated Products, Inc.

The content on this webpage is protected by copyright laws of the United States and of foreign countries. For requests to copy this content, [contact us](#).

Additional Legal Notices: <https://www.maximintegrated.com/en/legal>