

TPS6555xEVM-097

This user's guide describes the characteristics, operation, and use of the TPS6555xEVM-097 evaluation module (EVM). This EVM demonstrates the Texas Instruments TPS6555x integrated photo flash charger with IGBT driver. This user's guide includes setup instructions, a schematic diagram, a bill of materials (BOM), and PCB layout drawings for the evaluation module.

Contents

1	Introduction	2
2	Setup	2
3	Board Layout	4
4	Schematic and Bill of Materials	7
5	Related Documentation From Texas Instruments.....	9

List of Figures

1	Assembly Layer	5
2	Top Layer Routing.....	6
3	Bottom Layer Routing	7
4	TPS6555xEVM-097 Schematic.....	8

List of Tables

1	J5 Pinout	3
4.3	TPS6555xEVM-097 Bill of Materials	9

1 Introduction

The Texas Instruments TPS6555xEVM-097 evaluation module (EVM) helps designers evaluate the operation and performance of the TPS6555x family of devices. These devices are highly integrated flyback converters used to charge photo-flash capacitors.

The EVM contains one fully functional photo-flash charger capable of charging a photo-flash capacitor to 300 V from a battery with voltage between 1.8 V and 12 V. The EVM also provides a flash lamp and trigger circuit to help the designer evaluate the charging characteristics. Provisions have been made to disable the onboard lamp circuit so that the EVM can be connected to a user-supplied lamp and trigger circuit.

2 Setup

This section describes the jumpers and connectors on the EVM as well as how to properly connect, set up, and use the TPS6555xEVM-097.

WARNING

The TPS6555xEVM-097 produces high voltage and is designed to charge the bulk flash capacitor to more than 285 volts. This capacitor can maintain this voltage for a long time, even after the input power has been removed from the board. Do not touch any exposed metal on the TPS6555xEVM-097 without first discharging the bulk flash capacitor.

2.1 Input/Output Connector Descriptions

J1 – Vbatt — This is the positive battery voltage input connection to the converter. This voltage should be between 1.8 Vdc and 12 Vdc.

J2 – GND — This is the return connection for the battery voltage to the converter.

J3 – J5 — This is the positive digital supply voltage. This should be a regulated 5-V input.

J4 – GND — This is the return connection for the digital supply voltage.

J5 – REMOTE CONTROL — This connector is used to connect the EVM to a personal computer as an optional method of controlling the EVM. All necessary control inputs and outputs for the converter are present on this connector. The flash and charge signals are inverted before connecting to the TPS6555x IC on the EVM board. The pinout for the connector is shown in [Table 1](#).

J6 – User Lamp Module HV Connections — This connector is used to connect the EVM to a user-supplied lamp and trigger circuit. Pin 2 on this connector is the high-voltage side of the photo-flash capacitor; pin 1 is the trigger signal. See the EVM schematic for more information.

J7 – User Lamp Module HV Return Connections — This connector is used to connect the EVM to a user-supplied lamp and trigger circuit. Both pins of this connector are connected to the negative side of the photo-flash capacitor and provide the return path for the flash currents.

JP1 and JP2 – EVM Lamp Disconnect — These jumpers are used to disconnect the lamp and trigger circuit of the EVM so that a user-supplied lamp and trigger can be evaluated. The lamp and trigger are disconnected when the jumpers of both JP1 and JP2 are removed.

JP3 – Ipeak — This jumper is used to externally set the charge current. Pin 2 of this connector is tied directly to the Ipeak pin of the TPS6555x. Five volts and ground are provided on the connector so that a resistor divider can be formed to set the peak charge current anywhere between the TPS6555x minimum and maximum values. Connecting a jumper from pin 2 (Ipeak) to pin 1 (+5V) configures the TPS6555x minimum and maximum values. Connecting a jumper from pin 2 (Ipeak) to pin 3 (GND) configures the TPS6555x to charge the flash capacitor using the minimum peak current.

Table 1. J5 Pinout

Pin No.	Signal	Connection
1	Charge Complete	Output: An active low indicates the flash capacitor is charged.
2	GND	Signal ground
3	Charge	Input: A negative edge initiates the charging of the capacitor.
4	GND	Signal ground
5	Flash	Input: A low signal initiates a lamp flash.
6	GND	Signal ground
7	Ipeak	Input: Used to provide the peak current set-point of the charger
8	GND	Signal ground
9	+5V	The pin is connected to the +5-V plane of the EVM board.
10	GND	Signal ground

2.2 Setup and Operation With Onboard Lamp and Trigger Circuit

The following steps provide information about how to set up and operate the onboard lamp and trigger circuit.

1. Discharge the photo-flash capacitor by shorting C7 with a 15-k Ω resistor for more than 20 seconds. Use a multimeter to measure the voltage on C7, and verify that the voltage is close to zero before continuing or touching any connectors or components.
2. If needed, install jumpers across JP1 and JP2 to connect the onboard lamp and trigger circuit to the control circuitry.
3. Connect the positive lead of a regulated 5-V supply to J3.
4. Connect the negative lead of a regulated 5-V supply to J4.
5. Connect the positive lead of a battery or power supply to J1. This voltage can be between 1.8 V and 12 V.
6. Connect the negative lead of a battery or power supply to J2.
7. Turn on the 5-V supply.
8. Turn on the battery voltage supply.
9. Push and hold the *Charge* button to start charging the flash capacitor.
10. Release the *Charge* button when the green *Charge Complete* LED illuminates.
11. Push the *Flash* switch to flash the lamp.
12. Repeat steps 9 through 11 as desired.

2.3 Setup and Operation With User-Supplied Lamp and Trigger Circuit Operation

The following steps provide information about how to set up and operate the user-supplied lamp and trigger circuit.

1. Discharge the photo-flash capacitor by shorting C7 with a 15-k Ω resistor for more than 20 seconds. Use a multimeter to measure the voltage on C7, and verify that the voltage is close to zero before continuing or touching any connectors or components.
2. Remove jumpers across JP1 and JP2 to disconnect the onboard lamp and trigger circuit from the control circuitry. The TPS6555xEVM should only be used to flash a single flash tube.
3. Connect the high-voltage portion of the user-supplied lamp circuit to pin 2 of J6.
4. Connect the trigger portion of the user-supplied lamp to pin 1 of J6. See the EVM schematic to verify circuit connection.
5. Connect the ground portion of the user lamp circuit to pin 1 of J7.

Board Layout

6. Connect the positive lead of a regulated 5-V supply to J3.
7. Connect the negative lead of a regulated 5-V supply to J4.
8. Connect the positive lead of a battery or power supply to J1. This voltage can be between 1.8 V and 12 V.
9. Connect the negative lead of a battery or power supply to J2.
10. Turn on the 5-V supply.
11. Turn on the battery voltage supply.
12. Push and hold the *Charge* switch to start charging the flash capacitor.
13. Release the *Charge* switch when the green *Charge Complete* LED illuminates.
14. Push *Flash* switch to flash the lamp.
15. Repeat steps 12 through 14 as desired.

3 Board Layout

This section provides the TPS6555xEVM-097 board layout and illustrations.

Board layout is critical for all high-frequency switch mode power supplies. [Figure 1](#), [Figure 2](#), and [Figure 3](#) show the board layout for the TPS6555xEVM-097 PWB. The nodes with high switching frequencies and currents are kept as short as possible to minimize trace inductance. Careful attention has been given to the routing of high-frequency current loops and a single-point grounding scheme is used for all high-current and high-voltage traces. See the data sheet for specific layout guidelines.

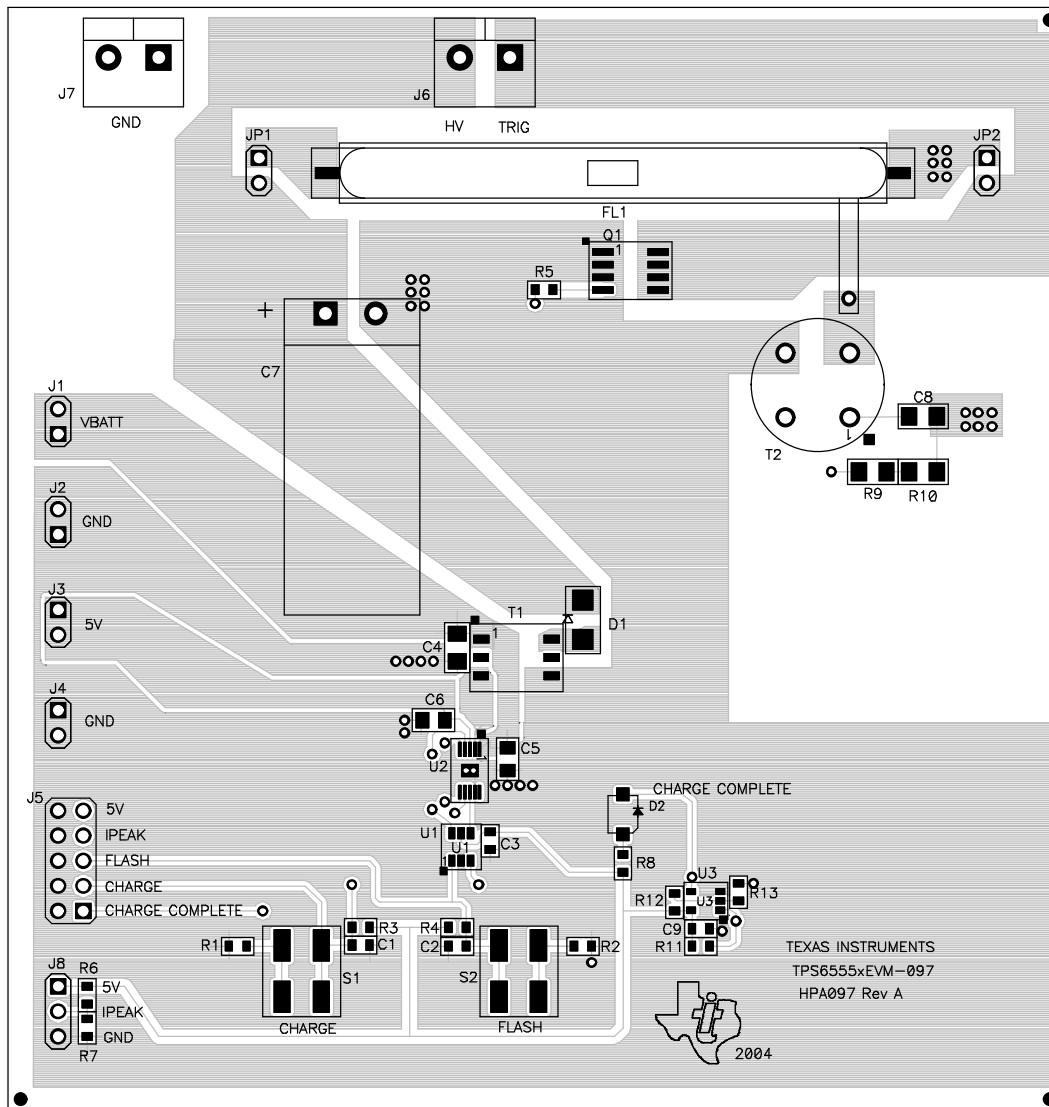

Figure 1. Assembly Layer

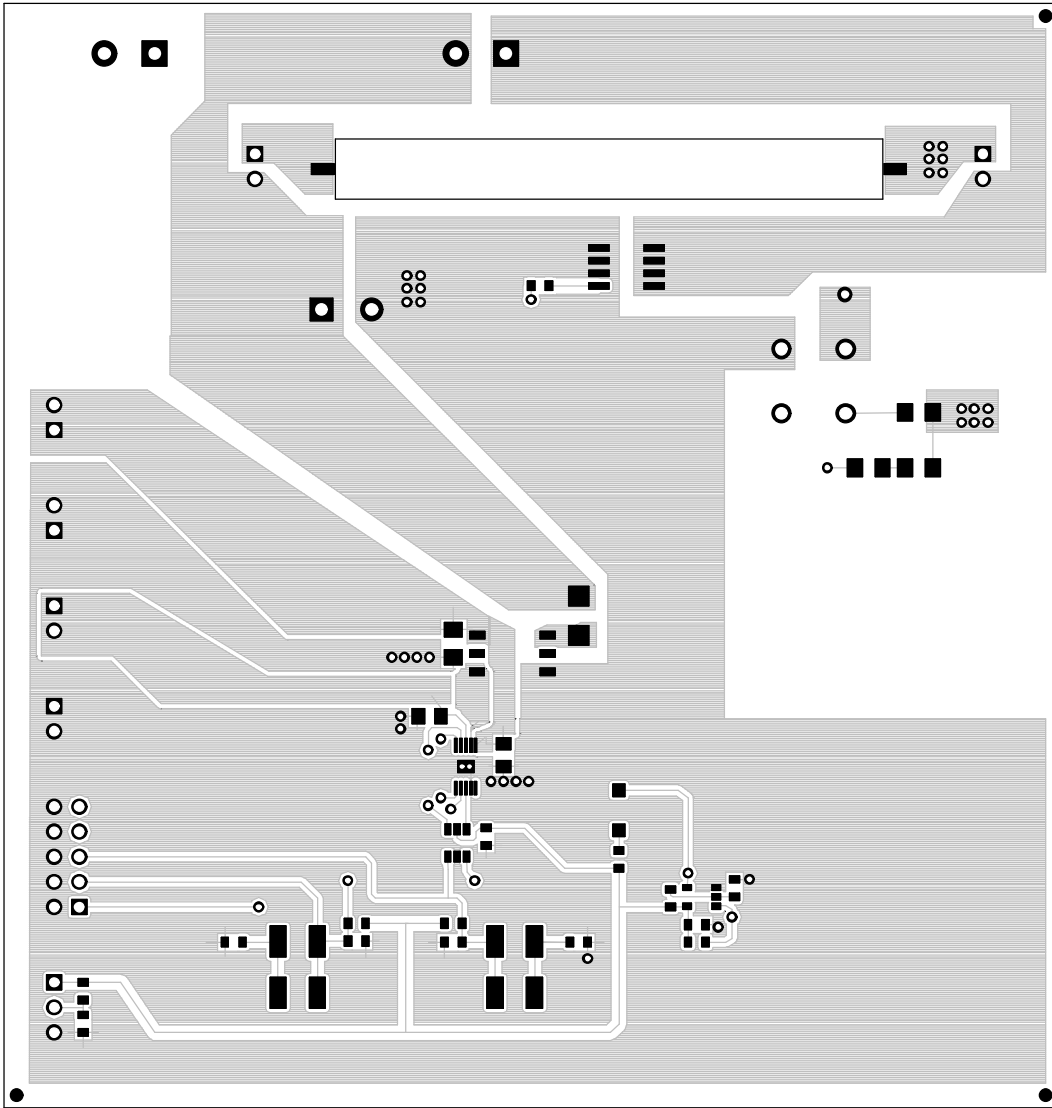

Figure 2. Top Layer Routing

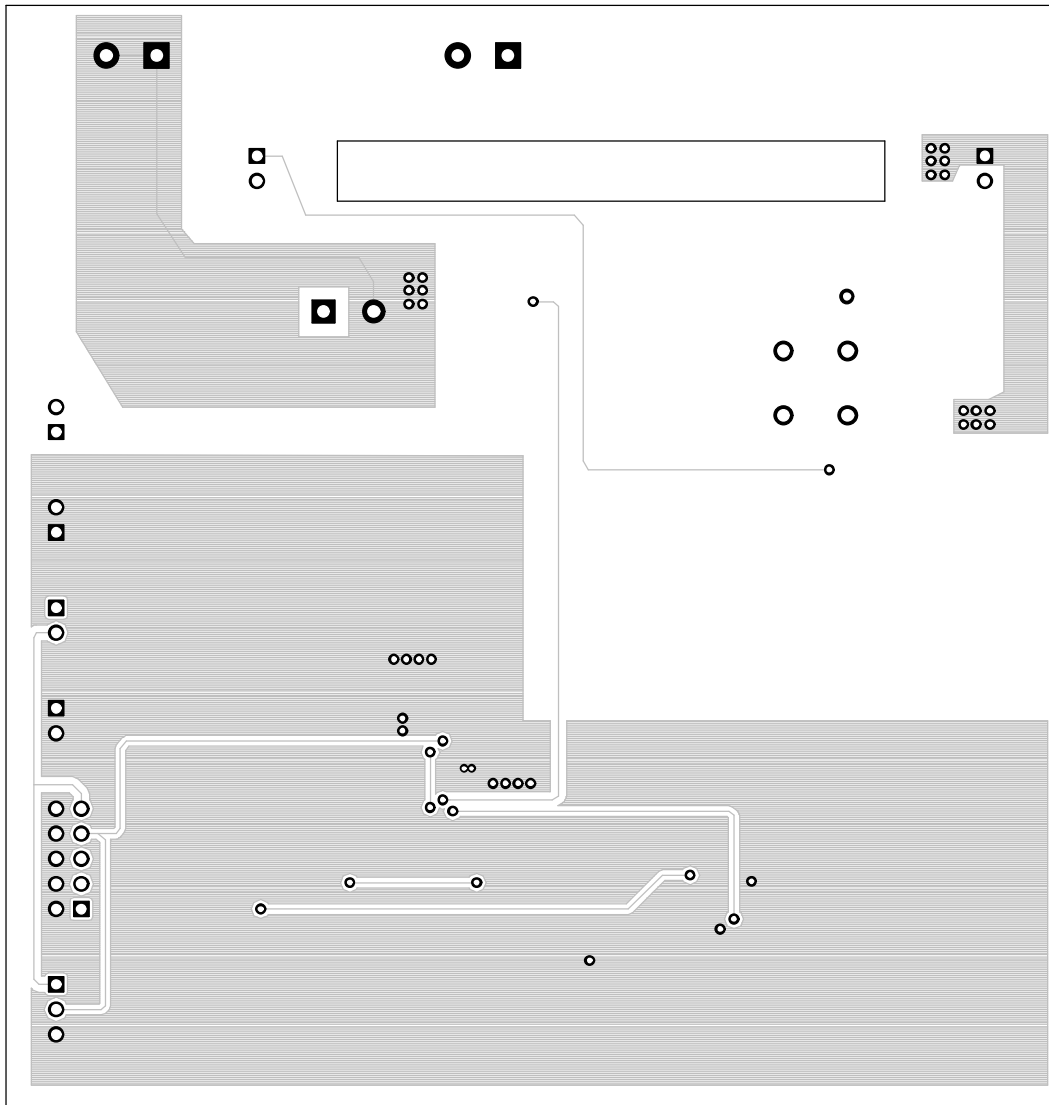

Figure 3. Bottom Layer Routing

4 Schematic and Bill of Materials

This section provides the TPS6555xEVM-097 schematic (see [Figure 4](#)) and bill of materials.

4.1 Schematic

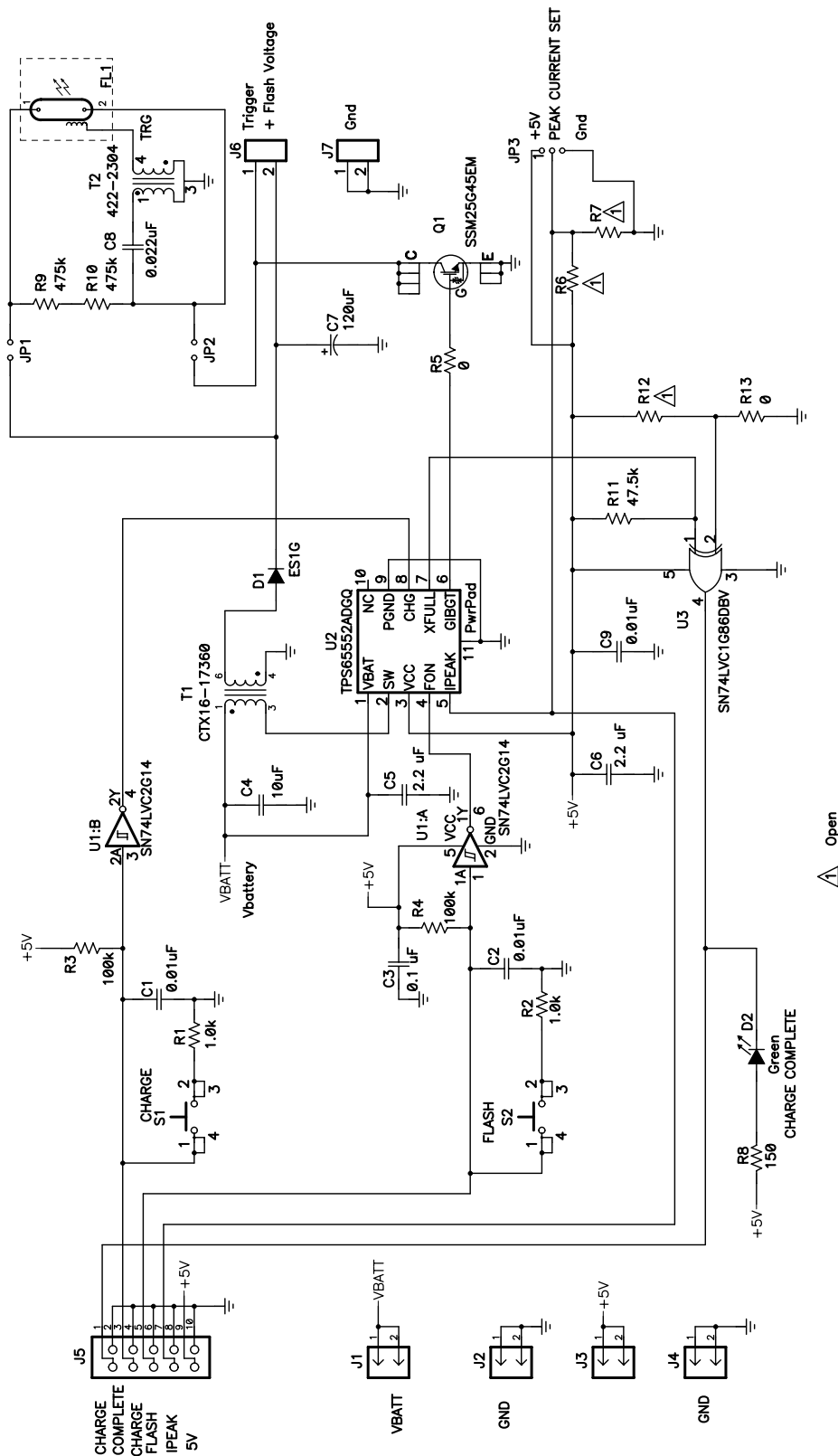

Figure 4. TPS6555xEVM-097 Schematic

4.2 Bill of Materials

Table 4.3. TPS6555xEVM-097 Bill of Materials

COUNT	Ref Des	DESCRIPTION	SIZE	MFR	PART NUMBER
3	C1, C2, C9	Capacitor, Ceramic, 0.01-uF, 50-V, X7R, 10%	0603	TDK	C1608X7R1H103KT
1	C3	Capacitor, Ceramic, 0.1-uF, 50-V, X7R, 10%	0603	TDK	C1608X7R1H104K
1	C4	Capacitor, Ceramic, 10-uF, 16-V, X7R, 10%	1206	TDK	C3216X7R1C106KT
2	C5, C6	Capacitor, Ceramic, 2.2-uF, 16-V, X7R, 10%	0805	TDK	C2012X7R1C225KT
1	C7	Capacitor, Aluminum, 120-uF, 330-VDC, ±20%	13 x 28 mm	Rubycon	330 FW 120A
1	C8	Capacitor, Ceramic, 0.022-uF, 630-V, X7R, 10%	1206	TDK	C3216X7R2J223KT
1	D1	Diode, Rectifier, 1-A, 400-V	SMA	Diodes Inc.	ES1G
1	D2	Diode, LED, Green, Gullwing, GW Type, 20ma, 7.5 mcd typ.	0.120 x 0.087	Panasonic	LN1361CTR
1	FL1	Flash Tube, 400v Max	2.126 x 0.157	Xicon	36FT050
4	J1 - J4	Header, 2-pin, 100mil spacing, (36-pin strip)	0.100 x 2	Sullins	PTC36SAAN
1	J5	Header, 2x5-pin, 100mil spacing (36-pin strip)	0.100 x 5 X 2	Sullins	PTC36SAAN
2	J6, J7	Terminal Block, 2-pin, 15-A, 5.1mm	0.40 x 0.35	OST	ED1609
2	JP1, JP2	Header, 2-pin, 100mil spacing, (36-pin strip)	0.100 x 2	Sullins	PTC36SAAN
1	JP3	Header, 3-pin, 100mil spacing, (36-pin strip)	0.100 x 3	Sullins	PTC36SAAN
1	Q1	Trans, NChan Insulated-Gate Bipolar, 450V, 150A	SO-8	Silicon Standard	SSM25G45EM
1	R1, R2	Resistor, Chip, 1.0k-Ohms, 1/16-W, 1%	0603	Std	Std
1	R11	Resistor, Chip, 47.5k-Ohms, 1/16-W, 1%	0603	Std	Std
2	R3, R4	Resistor, Chip, 100k-Ohms, 1/16-W, 1%	0603	Std	Std
2	R5, R13	Resistor, Chip, 0-Ohms, 1/16-W, 5%	0603	Std	Std
0	R6, R7, R12	Resistor, Chip, xx-Ohms, 1/16-W, 1%	0603		
1	R8	Resistor, Chip, 150-Ohms, 1/16-W, 1%	0603	Std	Std
2	R9, R10	Resistor, Chip, 475k-Ohms, 1/8W, 1%	1206	Std	Std
2	S1, S2	Switch, SPST, PB Momentary, Sealed Washable	0.245 X 0.251	C & K	KT11P2JM
1	T1	Transformer, Flyback, 1:10.2	0.300 x 0.240	Coiltronics	CTX16-17360
1	T2	Transformer, Trigger	0.197 Dia	Xicon	422-2304
1	U1	IC, Dual Schmitt-Trigger Inverter	SOT23-6	TI	SN74LVC2G14DBV
1	U2	IC, Photo Flash Charger and IGBT Driver	DGQ10	TI	TPS65552ADGQ
1	U3	Single 2-Input X-OR Gate	SOT-25	TI	SN74LVC1G86DBV
1	--	PCB, 4.4 In x 4.2 In x 0.062 In		Any	HPA097
3	--	Shunt, 100-mil, Black	0.100	3M	929950-00
4	--	Bumpon, Transparent	0.44" x 0.2"	3M	SJ5303

5 Related Documentation From Texas Instruments

TPS65552A, *Integrated Photo Flash Charger and IGBT Driver* data sheet ([SLVS567](#))

FCC Warnings

This equipment is intended for use in a laboratory test environment only. It generates, uses, and can radiate radio frequency energy and has not been tested for compliance with the limits of computing devices pursuant to subpart J of part 15 of FCC rules, which are designed to provide reasonable protection against radio frequency interference. Operation of this equipment in other environments may cause interference with radio communications, in which case the user at his own expense will be required to take whatever measures may be required to correct this interference.

EVM IMPORTANT NOTICE

Texas Instruments (TI) provides the enclosed product(s) under the following conditions:

This evaluation kit being sold by TI is intended for use for **ENGINEERING DEVELOPMENT OR EVALUATION PURPOSES ONLY** and is not considered by TI to be fit for commercial use. As such, the goods being provided may not be complete in terms of required design-, marketing-, and/or manufacturing-related protective considerations, including product safety measures typically found in the end product incorporating the goods. As a prototype, this product does not fall within the scope of the European Union directive on electromagnetic compatibility and therefore may not meet the technical requirements of the directive.

Should this evaluation kit not meet the specifications indicated in the EVM User's Guide, the kit may be returned within 30 days from the date of delivery for a full refund. **THE FOREGOING WARRANTY IS THE EXCLUSIVE WARRANTY MADE BY SELLER TO BUYER AND IS IN LIEU OF ALL OTHER WARRANTIES, EXPRESSED, IMPLIED, OR STATUTORY, INCLUDING ANY WARRANTY OF MERCHANTABILITY OR FITNESS FOR ANY PARTICULAR PURPOSE.**

The user assumes all responsibility and liability for proper and safe handling of the goods. Further, the user indemnifies TI from all claims arising from the handling or use of the goods. Please be aware that the products received may not be regulatory compliant or agency certified (FCC, UL, CE, etc.). Due to the open construction of the product, it is the user's responsibility to take any and all appropriate precautions with regard to electrostatic discharge.

EXCEPT TO THE EXTENT OF THE INDEMNITY SET FORTH ABOVE, NEITHER PARTY SHALL BE LIABLE TO THE OTHER FOR ANY INDIRECT, SPECIAL, INCIDENTAL, OR CONSEQUENTIAL DAMAGES.

TI currently deals with a variety of customers for products, and therefore our arrangement with the user **is not exclusive.**

TI assumes **no liability for applications assistance, customer product design, software performance, or infringement of patents or services described herein.**

Please read the EVM User's Guide and, specifically, the EVM Warnings and Restrictions notice in the EVM User's Guide prior to handling the product. This notice contains important safety information about temperatures and voltages. For further safety concerns, please contact the TI application engineer.

Persons handling the product must have electronics training and observe good laboratory practice standards.

No license is granted under any patent right or other intellectual property right of TI covering or relating to any machine, process, or combination in which such TI products or services might be or are used.

EVM WARNINGS AND RESTRICTIONS

It is important to operate this EVM within the input voltage range of 1.8 V to 12 V and the output voltage range of 285 V to 335 V.

The TPS6555xxEVM-097 produces high voltage and is designed to charge the bulk flash capacitor to more than 285 volts. This capacitor can maintain this voltage for a long time, even after the input power has been removed from the board. Do not touch any exposed metal on the TPS6555xxEVM-097 without first discharging the bulk flash capacitor.

Exceeding the specified input range may cause unexpected operation and/or irreversibel damage to the EVM. If there are questions concerning the input range, please contact a TI field representative prior to connecting the input power.

Applying loads outside of the specified output range may result in unintended operation and/or possible permanent damage to the EVM output. If there is uncertainty as to the load specification, please contact a TI field representative.

During normal operation, some circuit components may have case temperatures greater than 25°C. The EVM is designed to operate properly with certain components above 25°C as long as the input and output ranges are maintained. These components include but are not limited to linear regulators, switching transistors, pass transistors, and current sense resistors. These types of devices can be identified using the EVM schematic located in the EVM User's Guide. When placing measurement probes near these devices during operation, please be aware that these devices may be very warm to the touch.

Mailing address: Texas Instruments, Post Office Box 65503, Dallas, Texas 75265
Copyright © 2005, Texas Instruments Incorporated

IMPORTANT NOTICE

Texas Instruments Incorporated and its subsidiaries (TI) reserve the right to make corrections, modifications, enhancements, improvements, and other changes to its products and services at any time and to discontinue any product or service without notice. Customers should obtain the latest relevant information before placing orders and should verify that such information is current and complete. All products are sold subject to TI's terms and conditions of sale supplied at the time of order acknowledgment.

TI warrants performance of its hardware products to the specifications applicable at the time of sale in accordance with TI's standard warranty. Testing and other quality control techniques are used to the extent TI deems necessary to support this warranty. Except where mandated by government requirements, testing of all parameters of each product is not necessarily performed.

TI assumes no liability for applications assistance or customer product design. Customers are responsible for their products and applications using TI components. To minimize the risks associated with customer products and applications, customers should provide adequate design and operating safeguards.

TI does not warrant or represent that any license, either express or implied, is granted under any TI patent right, copyright, mask work right, or other TI intellectual property right relating to any combination, machine, or process in which TI products or services are used. Information published by TI regarding third-party products or services does not constitute a license from TI to use such products or services or a warranty or endorsement thereof. Use of such information may require a license from a third party under the patents or other intellectual property of the third party, or a license from TI under the patents or other intellectual property of TI.

Reproduction of information in TI data books or data sheets is permissible only if reproduction is without alteration and is accompanied by all associated warranties, conditions, limitations, and notices. Reproduction of this information with alteration is an unfair and deceptive business practice. TI is not responsible or liable for such altered documentation.

Resale of TI products or services with statements different from or beyond the parameters stated by TI for that product or service voids all express and any implied warranties for the associated TI product or service and is an unfair and deceptive business practice. TI is not responsible or liable for any such statements.

TI products are not authorized for use in safety-critical applications (such as life support) where a failure of the TI product would reasonably be expected to cause severe personal injury or death, unless officers of the parties have executed an agreement specifically governing such use. Buyers represent that they have all necessary expertise in the safety and regulatory ramifications of their applications, and acknowledge and agree that they are solely responsible for all legal, regulatory and safety-related requirements concerning their products and any use of TI products in such safety-critical applications, notwithstanding any applications-related information or support that may be provided by TI. Further, Buyers must fully indemnify TI and its representatives against any damages arising out of the use of TI products in such safety-critical applications.

TI products are neither designed nor intended for use in military/aerospace applications or environments unless the TI products are specifically designated by TI as military-grade or "enhanced plastic." Only products designated by TI as military-grade meet military specifications. Buyers acknowledge and agree that any such use of TI products which TI has not designated as military-grade is solely at the Buyer's risk, and that they are solely responsible for compliance with all legal and regulatory requirements in connection with such use.

TI products are neither designed nor intended for use in automotive applications or environments unless the specific TI products are designated by TI as compliant with ISO/TS 16949 requirements. Buyers acknowledge and agree that, if they use any non-designated products in automotive applications, TI will not be responsible for any failure to meet such requirements.

Following are URLs where you can obtain information on other Texas Instruments products and application solutions:

Products		Applications	
Amplifiers	amplifier.ti.com	Audio	www.ti.com/audio
Data Converters	dataconverter.ti.com	Automotive	www.ti.com/automotive
DSP	dsp.ti.com	Broadband	www.ti.com/broadband
Interface	interface.ti.com	Digital Control	www.ti.com/digitalcontrol
Logic	logic.ti.com	Military	www.ti.com/military
Power Mgmt	power.ti.com	Optical Networking	www.ti.com/opticalnetwork
Microcontrollers	microcontroller.ti.com	Security	www.ti.com/security
RFID	www.ti-rfid.com	Telephony	www.ti.com/telephony
Low Power Wireless	www.ti.com/lpw	Video & Imaging	www.ti.com/video
		Wireless	www.ti.com/wireless

Mailing Address: Texas Instruments, Post Office Box 655303, Dallas, Texas 75265
Copyright © 2007, Texas Instruments Incorporated