

## TUSB501-Q1 USB 3.0 Single-Channel Redriver with Equalization

### 1 Features

- Q100 Automotive Qualified
- Aggressive Low-Power Architecture (Typical):
  - 126 mW Active Power
  - 20 mW in U2/U3
  - 4 mW with No Connection
- Automatic LFPS DE Control
- Excellent Jitter and Loss Compensation
  - 32 inches of FR4 4 mil Stripline
  - 3 m of 30 AWG cable
- Integrated Termination
- Small 2 x 2 mm QFN Package
- Selectable Receiver Equalization, Transmitter De-Emphasis and Output Swing
- Hot-Plug Capable
- ESD Protection  $\pm 5$  kV HBM and 1500 V CDM

### 2 Applications

- Cell Phones
- Computers
- Docking Stations
- TVs
- Active Cables
- Backplanes

### 3 Description

The TUSB501-Q1 is a 3<sup>rd</sup> generation 3.3-V USB 3.0 single-channel redriver. When 5 Gbps SuperSpeed USB signals travel across a PCB or cable, signal integrity degrades due to loss and inter-symbol interference. The TUSB501-Q1 recovers incoming data by applying equalization that compensates channel loss, and drives out signals with a high differential voltage. This extends the possible channel length, and enables systems to pass USB 3.0 compliance. The TUSB501-Q1 advanced state machine makes it transparent to hosts and devices.

After power up, the TUSB501-Q1 periodically performs receiver detection on the TX pair. If it detects a SuperSpeed USB receiver, RX termination becomes enabled, and the TUSB501-Q1 is ready to redrive.

The receiver equalizer has three gain settings that are controlled by pin EQ: 3 dB, 6 dB, and 9 dB. This should be set based on amount of loss before the TUSB501-Q1. Likewise, the output driver supports configuration of De-Emphasis and Output Swing (pins DE and OS). These settings allow the TUSB501-Q1 to be flexibly placed in the SuperSpeed USB path, with optimal performance.

Over previous generations, the TUSB501-Q1 features reduced power in all link states, a stronger OS option, improved receiver equalization settings, and an intelligent LFPS Controller. This controller senses the low frequency signals and automatically disables driver de-emphasis, for full USB 3.0 compliance.

The TUSB501-Q1 is packaged in a small 2 x 2 mm QFN, and operates through an industrial temperature range of  $-40^{\circ}\text{C}$  to  $105^{\circ}\text{C}$ .

#### Device Information<sup>(1)</sup>

PART NUMBER	PACKAGE	BODY SIZE (NOM)
TUSB501-Q1	WSON	2.00 mm x 2.00 mm

(1) For all available packages, see the orderable addendum at the end of the data sheet.

#### Simple Application

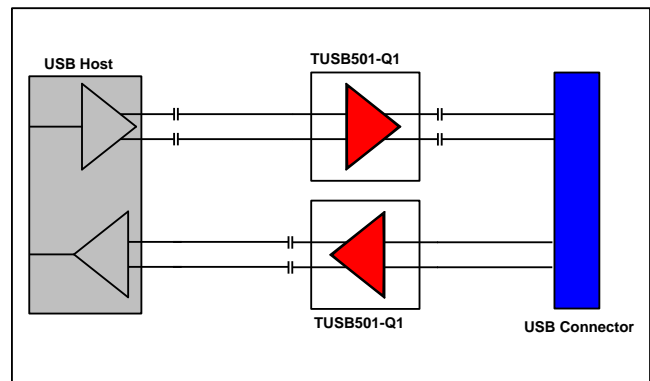

Copyright © 2016, Texas Instruments Incorporated



## Table of Contents

<b>1</b>	<b>Features</b> .....	<b>1</b>	9.1	Overview .....	<b>10</b>
<b>2</b>	<b>Applications</b> .....	<b>1</b>	9.2	Functional Block Diagram .....	<b>11</b>
<b>3</b>	<b>Description</b> .....	<b>1</b>	9.3	Feature Description .....	<b>11</b>
<b>4</b>	<b>Revision History</b> .....	<b>2</b>	9.4	Device Functional Modes .....	<b>12</b>
<b>5</b>	<b>Device Comparison Table</b> .....	<b>3</b>	<b>10</b>	<b>Application and Implementation</b> .....	<b>13</b>
<b>6</b>	<b>Pin Configuration and Functions</b> .....	<b>3</b>	10.1	Application Information .....	<b>13</b>
<b>7</b>	<b>Specifications</b> .....	<b>4</b>	10.2	Typical Application .....	<b>13</b>
7.1	Absolute Maximum Ratings .....	<b>4</b>	<b>11</b>	<b>Power Supply Recommendations</b> .....	<b>14</b>
7.2	ESD Ratings .....	<b>4</b>	<b>12</b>	<b>Layout</b> .....	<b>15</b>
7.3	Recommended Operating Conditions .....	<b>4</b>	12.1	Layout Guidelines .....	<b>15</b>
7.4	Thermal Information .....	<b>4</b>	12.2	Layout Example .....	<b>16</b>
7.5	Power Supply Characteristics .....	<b>5</b>	<b>13</b>	<b>Device and Documentation Support</b> .....	<b>17</b>
7.6	DC Electrical Characteristics .....	<b>5</b>	13.1	Community Resources .....	<b>17</b>
7.7	AC Electrical Characteristics .....	<b>6</b>	13.2	Trademarks .....	<b>17</b>
7.8	Typical Characteristics .....	<b>7</b>	13.3	Electrostatic Discharge Caution .....	<b>17</b>
<b>8</b>	<b>Parameter Measurement Information</b> .....	<b>8</b>	13.4	Glossary .....	<b>17</b>
<b>9</b>	<b>Detailed Description</b> .....	<b>10</b>	<b>14</b>	<b>Mechanical, Packaging, and Orderable Information</b> .....	<b>17</b>

## 4 Revision History

DATE	REVISION	NOTES
April 2016	*	Initial release.

## 5 Device Comparison Table

USB3.0 Re-drivers (5 Gbps)				
FEATURE	TUSB501-Q1	TUSB551	SN65LVPE502A	SN65LVPE512
Package	8 Pin WSON	12 Pin X2QFN	24 Pin VQFN	24 Pin WQFN
Package Size	2 mm x 2 mm	1.6 mm x 1.6 mm	3 mm x 3 mm, 4 mm x 4 mm	3 mm x 3 mm
Package Pitch	0.5 mm	0.4 mm	0.4 mm, 0.5 mm	0.4 mm
Channels	1	1	2	2
Active Power (Typical)	126 mW	< 130 mW	315 mW	315 mW
U2/U3	20 mW	< 22 mW	70 mW	70 mW
Low Power	4 mW (NC)	< 8 mW (NC)	3.6 $\mu$ W (Sleep)	3.6 $\mu$ W (Sleep)
EQ Settings (dB)	3, 6, 9	3, 6, 9	0, 7, 15	0, 7, 15
ESD Protection	5 kV HBM	2 kV HBM	5 kV HBM	5 kV HBM
Power Supply	3.3 VDC	1.8 VDC	3.3 VDC	3.3 VDC

## 6 Pin Configuration and Functions

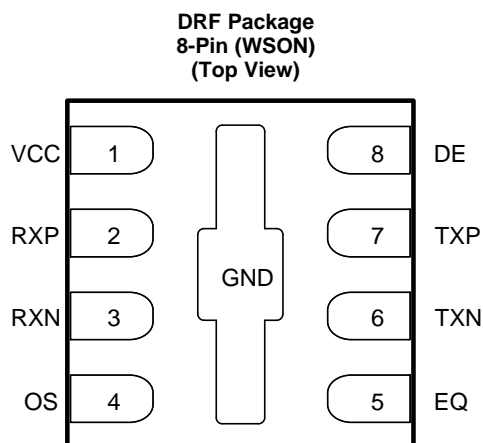

### Pin Functions

PIN		TYPE	DESCRIPTION
NAME	NO.		
RXP	2	Differential I/O	Differential input pair for 5 Gbps SuperSpeed USB signals.
RXN	3		
TXN	6		Differential output pair for 5 Gbps SuperSpeed USB signals.
TXP	7		
EQ	5	CMOS Input	Sets the receiver equalizer gain. 3-state input with integrated pull-up and pull-down resistors.
DE	8		Sets the output de-emphasis gain. 3-state input with integrated pull-up and pull-down resistors.
OS	4		Sets the output swing (differential voltage amplitude). 2-state input with an integrated pull-down resistor.
VCC	1	Power	3.3-V power supply
GND	Thermal Pad		Reference ground

## 7 Specifications

### 7.1 Absolute Maximum Ratings

 over operating free-air temperature range (unless otherwise noted) <sup>(1)</sup>

		MIN	MAX	UNIT
Supply voltage range <sup>(2)</sup>	V <sub>CC</sub>	-0.5	4	V
Voltage range at any input or output terminal	Differential I/O	-0.5	4	V
	CMOS inputs	-0.5	V <sub>CC</sub> + 0.5	V
Storage temperature, T <sub>STG</sub>		-65	150	°C
Maximum junction temperature, T <sub>J</sub>		-40	125	°C

- (1) Stresses beyond those listed under absolute maximum ratings may cause permanent damage to the device. These are stress ratings only and functional operation of the device at these or any conditions beyond those indicated under recommended operating conditions is not implied. Exposure to absolute-maximum-rated conditions for extended periods may affect device reliability.
- (2) All voltage values are with respect to the GND terminals.

### 7.2 ESD Ratings

		VALUE	UNIT
V <sub>(ESD)</sub> Electrostatic discharge	Human-body model (HBM), per ANSI/ESDA/JEDEC JS-001 <sup>(1)</sup>	±5000	V
	Charged-device model (CDM), per JEDEC specification JESD22-C101 <sup>(2)</sup>	±1500	

- (1) JEDEC document JEP155 states that 500-V HBM allows safe manufacturing with a standard ESD control process.
- (2) JEDEC document JEP157 states that 250-V CDM allows safe manufacturing with a standard ESD control process.

### 7.3 Recommended Operating Conditions

over operating free-air temperature range (unless otherwise noted)

		MIN	NOM	MAX	UNIT
V <sub>CC</sub>	Main power supply	3	3.3	3.6	V
T <sub>A</sub>	Operating free-air temperature	-40		105	°C
C <sub>AC</sub>	AC coupling capacitor	75	100	200	nF

### 7.4 Thermal Information

THERMAL METRIC <sup>(1)</sup>		TUSB501-Q1	UNITS
		DRF (WSON)	
R <sub>θJA</sub>	Junction-to-ambient thermal resistance	105.5	°C/W
R <sub>θJC(top)</sub>	Junction-to-case(top) thermal resistance	47.5	°C/W
R <sub>θJB</sub>	Junction-to-board thermal resistance	70.9	°C/W
Ψ <sub>JT</sub>	Junction-to-top characterization parameter	10.0	°C/W
Ψ <sub>JB</sub>	Junction-to-board characterization parameter	70.9	°C/W
R <sub>θJC(bottom)</sub>	Junction-to-case(bottom) thermal resistance	51.8	°C/W

- (1) For more information about traditional and new thermal metrics, see the IC Package Thermal Metrics application report, [SPRA953](#).

## 7.5 Power Supply Characteristics

over operating free-air temperature range (unless otherwise noted)

PARAMETER		TEST CONDITIONS	MIN	TYP <sup>(1)</sup>	MAX <sup>(2)</sup>	UNIT
I <sub>CC-ACTIVE</sub>	Average active current	Link in U0 with SuperSpeed USB data transmission, OS = Low		38.1		mA
		Link in U0 with SuperSpeed USB data transmission, OS = High		43.8	65	
I <sub>CC-IDLE</sub>	Average current in idle state	Link has some activity, not in U0, OS = Low		29.8		mA
I <sub>CC-U2U3</sub>	Average current in U2/U3	Link in U2 or U3		6.1		mA
I <sub>CC-NC</sub>	Average current with no connection	No SuperSpeed USB device is connected to TXP, TXN		1.3		mA
P <sub>D</sub>	Power Dissipation in U0	OS = Low		126		mW
		OS = High		145	234	

(1) TYP values use V<sub>CC</sub> = 3.3 V, T<sub>A</sub> = 25°C.

(2) MAX values use V<sub>CC</sub> = 3.6 V, T<sub>A</sub> = -40°C.

## 7.6 DC Electrical Characteristics

over operating free-air temperature range (unless otherwise noted)

PARAMETER		TEST CONDITIONS	MIN	TYP	MAX	UNIT
<b>3-State CMOS Inputs (EQ, DE)</b>						
V <sub>IH</sub>	High-level input voltage		2.8			V
V <sub>IM</sub>	Mid-level input voltage			V <sub>CC</sub> / 2		V
V <sub>IL</sub>	Low-level input voltage				0.6	V
V <sub>F</sub>	Floating voltage	V <sub>IN</sub> = High impedance		V <sub>CC</sub> / 2		V
R <sub>PU</sub>	Internal pull-up resistance			190		kΩ
R <sub>PD</sub>	Internal pull-down resistance			190		kΩ
I <sub>IH</sub>	High-level input current	V <sub>IN</sub> = 3.6 V			36	μA
I <sub>IL</sub>	Low-level input current	V <sub>IN</sub> = GND, V <sub>CC</sub> = 3.6 V	-36			μA
<b>2-State CMOS Input (OS)</b>						
V <sub>IH</sub>	High-level input voltage		2			V
V <sub>IL</sub>	Low-level input voltage				0.5	V
V <sub>F</sub>	Floating voltage	V <sub>IN</sub> = High impedance		GND		V
R <sub>PD</sub>	Internal pull-down resistance			270		kΩ
I <sub>IH</sub>	High-level input current	V <sub>IN</sub> = 3.6 V			26	μA
I <sub>IL</sub>	Low-level input current	V <sub>IN</sub> = GND	-1			μA

## 7.7 AC Electrical Characteristics

over operating free-air temperature range (unless otherwise noted)

PARAMETER		TEST CONDITIONS	MIN	TYP	MAX	UNIT
<b>Differential Receiver (RXP, RXN)</b>						
$V_{DIFF-pp}$	Input differential voltage swing	AC-coupled differential peak-to-peak signal	100		1200	mV <sub>pp</sub>
$V_{CM-RX}$	Common-mode voltage bias in the receiver (DC)			3.3		V
$Z_{RX-DIFF}$	Differential input impedance (DC)	Present after a SuperSpeed USB device is detected on TXP/TXN	72	91	120	$\Omega$
$Z_{RX-CM}$	Common-mode input impedance (DC)	Present after a SuperSpeed USB device is detected on TXP, TXN	18	22.8	30	$\Omega$
$Z_{RX-HIGH-IMP-DC-POS}$	Common-mode input impedance with termination disabled (DC)	Present when no SuperSpeed USB device is detected on TXP, TXN. Measured over the range of 0-500 mV with respect to GND.	25	35		k $\Omega$
$V_{RX-LFPS-DET-DIFF-pp}$	Low Frequency Periodic Signaling (LFPS) Detect Threshold	Below the minimum is squelched	100		300	mV <sub>pp</sub>
<b>Differential Transmitter (TXP, TXN)</b>						
$V_{TX-DIFF-PP}$	Transmitter differential voltage swing (transition-bit)	OS = Low, No load		930		mV <sub>pp</sub>
		OS = High, No load		1300		
$V_{TX-DE-RATIO}$	Transmitter de-emphasis	DE = Floating, OS = Low		-3.5		dB
$C_{TX}$	TX input capacitance to GND	At 2.5 GHz		1.25		pF
$Z_{TX-DIFF}$	Differential impedance of the driver		75	93	125	$\Omega$
$Z_{TX-CM}$	Common-mode impedance of the driver	Measured with respect to AC ground over 0-500 mV	18.75		31.25	$\Omega$
$I_{TX-SC}$	TX short circuit current	TX $\pm$ shorted to GND			60	mA
$V_{CM-TX}$	Common-mode voltage bias in the transmitter (DC)		1.2		2.5	V
$V_{CM-TX-AC}$	AC common-mode voltage swing in active mode	Within U0 and within LFPS			100	mV <sub>pp</sub>
$V_{TX-IDLE-DIFF-AC-pp}$	Differential voltage swing during electrical idle	Tested with a high-pass filter	0		10	mV <sub>pp</sub>
$V_{TX-CM-DeltaU1-U0}$	Absolute delta of DC CM voltage during active and idle states	Restrict the test condition to meet 100 mV			100	mV
$V_{TX-idle-diff-DC}$	DC electrical idle differential output voltage	Voltage must be low pass filtered to remove any AC component	0		12	mV
<b>Differential Transmitter (TXP, TXN)</b>						
$t_R, t_F$	Output rise, fall time see <a href="#">Figure 6</a>	20%-80% of differential voltage measured 1 inch from the output pin		80		ps
$t_{RF-MM}$	Output Rise, Fall time mismatch	20%-80% of differential voltage measured 1 inch from the output pin			20	ps
$t_{diff-LH}, t_{diff-HL}$	Differential propagation delay see <a href="#">Figure 4</a>	De-emphasis = -3.5 dB propagation delay between 50% level at input and output		290		ps
$t_{idleEntry}, t_{idleExit}$	Idle entry and exit times see <a href="#">Figure 5</a>			3.6		ns

## AC Electrical Characteristics (continued)

over operating free-air temperature range (unless otherwise noted)

PARAMETER		TEST CONDITIONS	MIN	TYP	MAX	UNIT
<b>Timing</b>						
$t_{\text{READY}}$	Time from power applied until RX termination	Apply 0 V to VCC, connect SuperSpeed USB termination to TX±, apply 3.3 V to VCC, and measure when Z <sub>RX-DIFF</sub> is enabled.		9		ms
<b>Jitter</b>						
T <sub>JTX-EYE</sub>	Total jitter <sup>(1)</sup> <sup>(2)</sup>	EQ = Floating, OS = High, DE = High See Figure 3.		0.213		UI <sup>(3)</sup>
D <sub>JTX</sub>	Deterministic jitter <sup>(2)</sup>			0.197		UI <sup>(3)</sup>
R <sub>JTX</sub>	Random jitter <sup>(2)</sup> <sup>(4)</sup>			0.016		UI <sup>(3)</sup>

- (1) Includes R<sub>J</sub> at 10<sup>-12</sup>.
- (2) Measured at the ends of reference channel in Figure 3 with K28.5 pattern, V<sub>ID</sub> = 1000 mV<sub>pp</sub>, 5 Gbps, -3.5 dB de-emphasis from source.
- (3) UI = 200 ps.
- (4) R<sub>J</sub> calculated as 14.069 times the RMS random jitter for 10<sup>-12</sup> BER.

## 7.8 Typical Characteristics

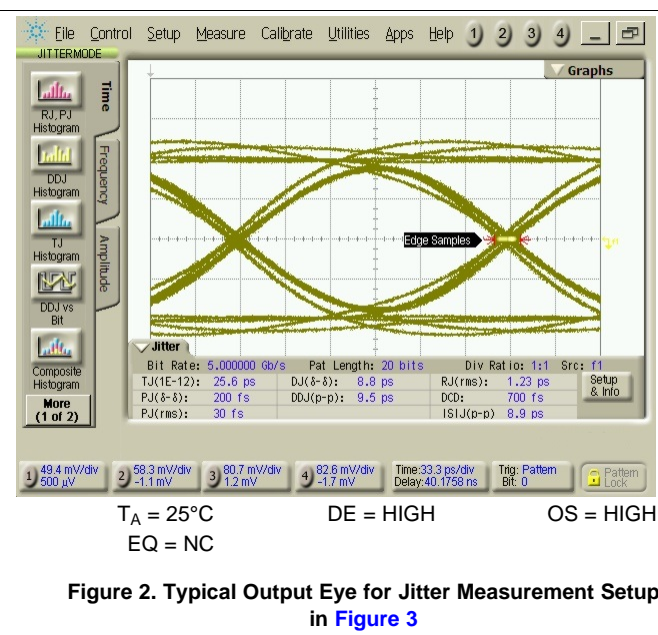
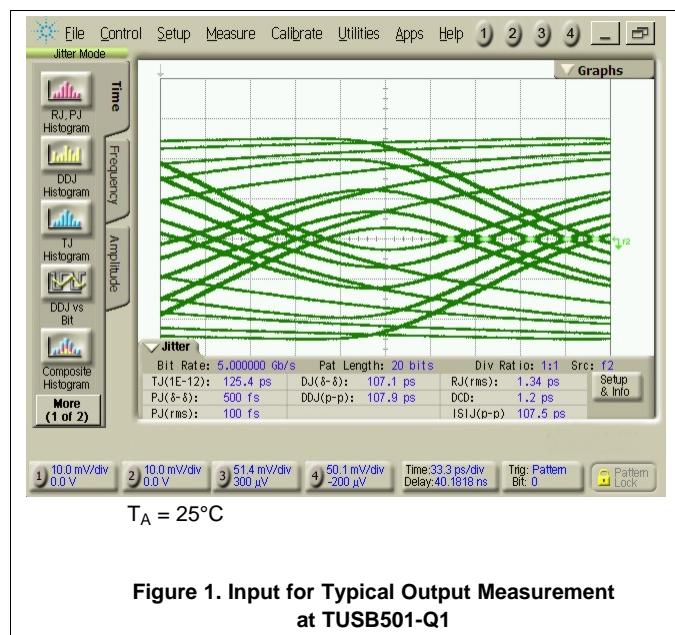

## 8 Parameter Measurement Information

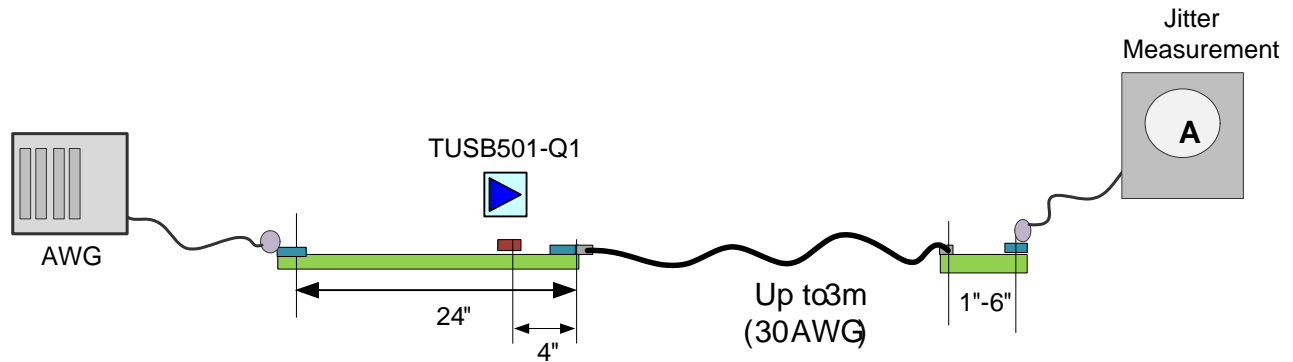

Figure 3. Jitter Measurement Setup

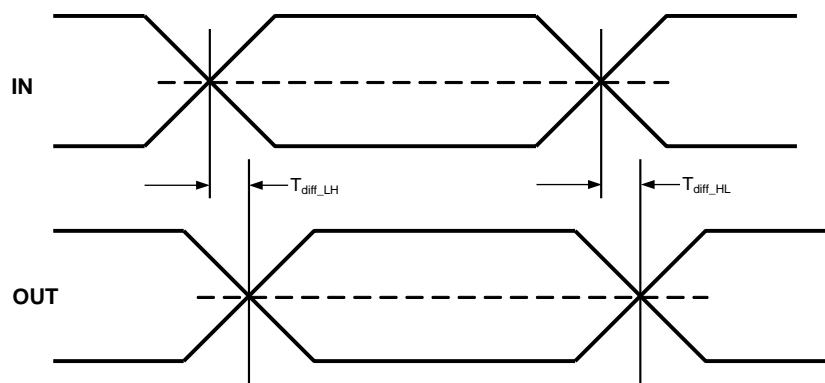

Figure 4. Propagation Delay

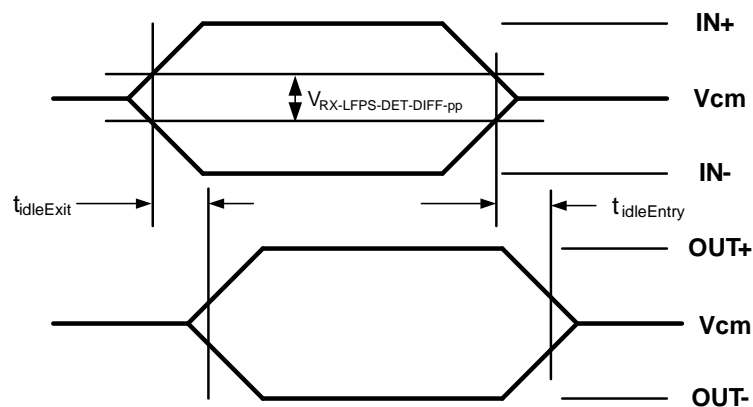

Figure 5. Electrical Idle Mode Exit and Entry Delay

Parameter Measurement Information (continued)

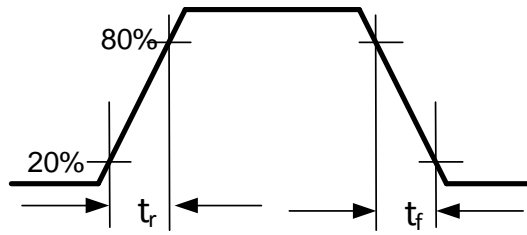

Figure 6. Output Rise and Fall Times

## 9 Detailed Description

### 9.1 Overview

When 5 Gbps SuperSpeed USB signals travel across a PCB or cable, signal integrity degrades due to loss and inter-symbol interference. The TUSB501-Q1 recovers incoming data by applying equalization that compensates for channel loss, and drives out signals with a high differential voltage. This extends the possible channel length, and enables systems to pass USB 3.0 compliance.

The TUSB501-Q1 advanced state machine makes it transparent to hosts and devices. After power up, the TUSB501-Q1 periodically performs receiver detection on the TX pair. If it detects a SuperSpeed USB receiver, the RX termination is enabled, and the TUSB501-Q1 is ready to re-drive.

The device aggressive Low-Power Architecture operates at a 3.3-V power supply and achieves enhanced performance, as low as 3 mW with no connection and 126 mW in active state. The receiver equalizer has three gain settings that are controlled by terminal EQ: 3 dB, 6 dB, and 9 dB. The equalization should be set based on amount of insertion loss in the channel before the TUSB501-Q1. Likewise, the output driver supports configuration of De-Emphasis and Output Swing (terminals DE and OS). The automatic LFPS De-Emphasis control further enables the system to be USB3.0 compliant. The TUSB501-Q1 operates over the industrial temperature range of -40°C to 85°C in a small 2 x 2 mm WSON package.

**Table 1. Control Pin Effects (Typical Values)**

PIN	DESCRIPTION	LOGIC STATE	GAIN
EQ	Equalization Amount	Low	3 dB
		Floating	6 dB
		High	9 dB

PIN	DESCRIPTION	LOGIC STATE	OUTPUT DIFFERENTIAL VOLTAGE FOR THE TRANSITION BIT
OS	Output Swing Amplitude	Low	930 mV <sub>pp</sub>
		High	1300 mV <sub>pp</sub>

PIN	DESCRIPTION	LOGIC STATE	DE-EMPHASIS RATIO <sup>(1)</sup>	
			FOR OS = LOW	FOR OS = HIGH
DE	De-Emphasis Amount	Low	0 dB	-2.6 dB
		Floating	-3.5 dB	-5.9 dB
		High	-6.2 dB	-8.3 dB

(1) Typical values

## 9.2 Functional Block Diagram

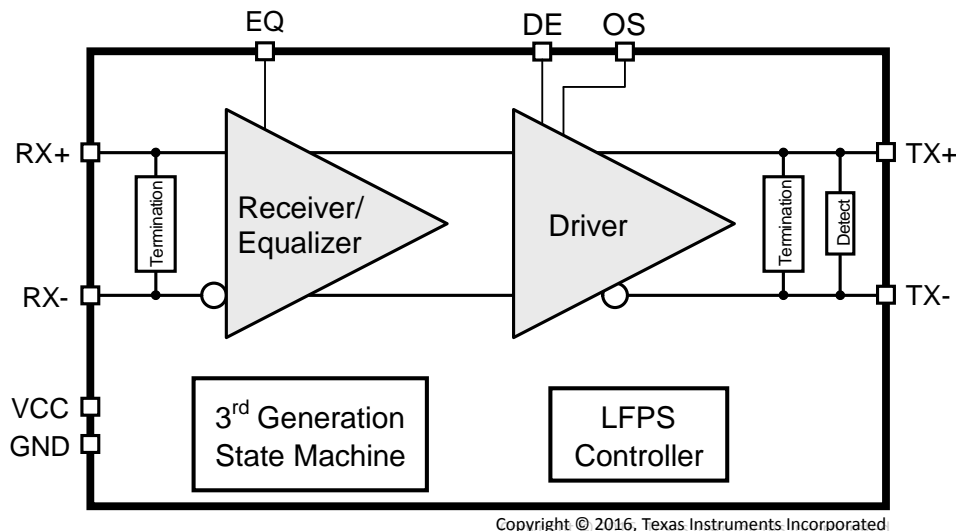

## 9.3 Feature Description

### 9.3.1 Receiver Equalization

The purpose of receiver equalization is to compensate for channel insertion loss and inter-symbol interference in the system before the input of the TUSB501-Q1. The receiver overcomes these losses by attenuating the low frequency components of the signals with respect to the high frequency components. The proper gain setting should be selected to match the channel insertion loss before the input of the TUSB501-Q1.

### 9.3.2 De-Emphasis Control and Output Swing

The differential driver output provides selectable de-emphasis and output swing control in order to achieve USB3.0 compliance. The TUSB501-Q1 offers a unique way to adjust output de-emphasis and transmitter swing based on the OS and DE terminals. The level of de-emphasis required in the system depends on the channel length after the output of the re-driver.

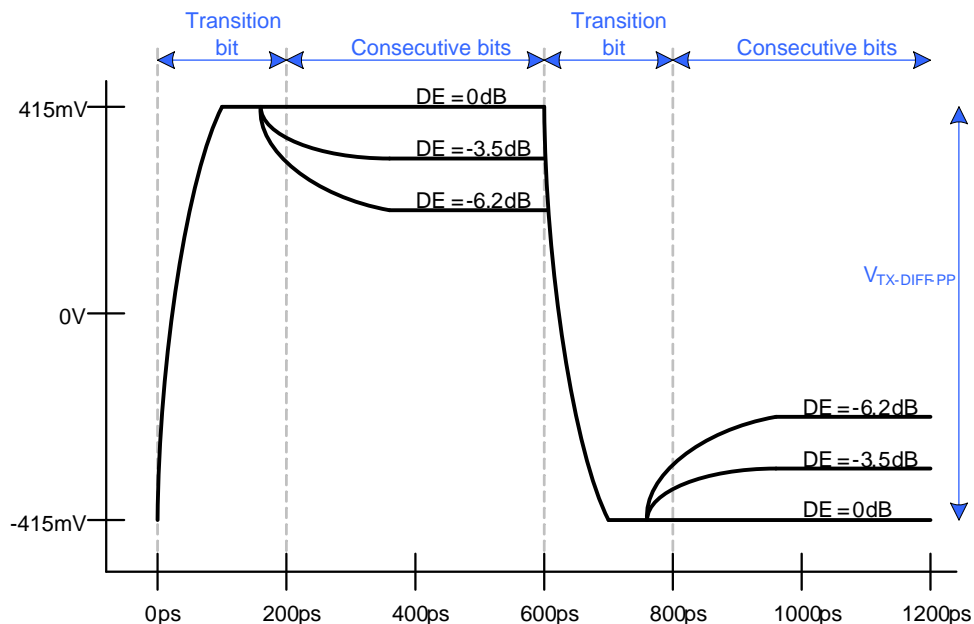

Figure 7. Transmitter Differential Voltage, OS = L

## Feature Description (continued)

### 9.3.3 Automatic LFPS Detection

The TUSB501-Q1 features an intelligent low frequency periodic signaling (LFPS) controller. The controller senses the low frequency signals and automatically disables the driver de-emphasis, for full USB3.0 compliance.

### 9.3.4 Automatic Power Management

The TUSB501-Q1 deploys RX detect, LFPS signal detection and signal monitoring to implement an automatic power management scheme to provide active, U2/U3 and disconnect modes. The automatic power management is driven by an advanced state machine, which is implemented to manage the device such that the re-driver operates smoothly in the links.

## 9.4 Device Functional Modes

### 9.4.1 Disconnect Mode

The Disconnect mode is the lowest power state of the TUSB501-Q1. In this state, the TUSB501-Q1 periodically checks for far-end receiver termination on both TX. Upon detection of the far-end receiver's termination on both ports, the TUSB501-Q1 will transition to U0 mode.

### 9.4.2 U Modes

#### 9.4.2.1 U0 Mode

The U0 mode is the highest power state of the TUSB501-Q1. Anytime super-speed traffic is being received, the TUSB501-Q1 remains in this mode.

#### 9.4.2.2 U2/U3 Mode

Next to the disconnect mode, the U2/U3 mode is next lowest power state. While in this mode, the TUSB501-Q1 periodically performs far-end receiver detection.

## 10 Application and Implementation

### NOTE

Information in the following applications sections is not part of the TI component specification, and TI does not warrant its accuracy or completeness. TI's customers are responsible for determining suitability of components for their purposes. Customers should validate and test their design implementation to confirm system functionality.

### 10.1 Application Information

One example of the TUSB501-Q1 used in a Host application on transmit and receive channels is shown in Figure 8. The re-driver is needed on the transmit path to pass transmitter compliance due to loss between the Host and connector. The re-driver uses the equalization to recover the insertion loss and re-drive the signal with boosted swing down the remaining channel, through the USB3.0 cable, and into the device PCB. Additionally, the TUSB501-Q1 is needed on the receive channel for the Host to pass receiver jitter tolerance. The re-driver recovers the loss from the Device PCB, connector, and USB 3.0 cable and re-drives the signal going into the Host receiver. The equalization, output swing, and de-emphasis settings are dependent upon the type of USB3.0 signal path and end application.

### 10.2 Typical Application

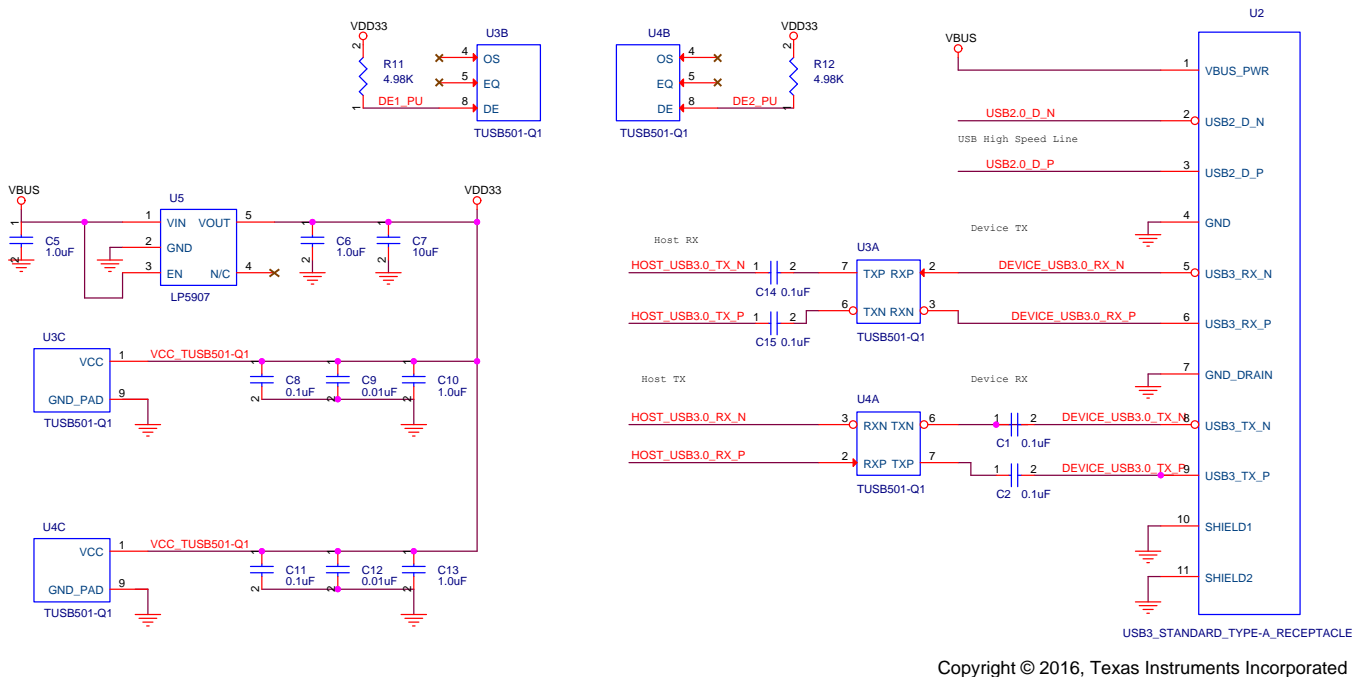

Figure 8. Application Schematic

#### 10.2.1 Design Requirements

For this design example, use the parameter shown in Table 2.

Table 2. Design Parameters

PARAMETER	VALUE
VCC	3.3 V
Supply nominal current	250 mA
Operating free-air temperature	T <sub>A</sub> = 25°C
CAC AC coupling capacitor	100 nF
Pull-up resistors	4.98 kΩ

### 10.2.2 Detailed Design Procedure

To begin the design process, determine the following:

- Equalization (EQ) setting
- De-Emphasis (DE) setting
- Output Swing Amplitude (OS) setting

The equalization should be set based on the insertion loss in the pre-channel (channel before the TUSB501-Q1 device). The input voltage to the device is able to have a large range because of the receiver sensitivity and the available EQ settings. The EQ terminal can be pulled high through a resistor to VCC, low through a resistor to ground, or left floating. The application schematic above shows the implementation.

The De-Emphasis setting should be set based on the length and characteristics of the post channel (channel after the TUSB501-Q1 device). Output de-emphasis can be tailored using the DE terminal. This terminal should be pulled high through a resistor to VCC, low through a resistor to ground, or left floating. Figure 8 shows the implementation. The output swing setting can also be configured based on the amplitude needed to pass the compliance test. This setting will also be based on the length of interconnect or cable the TUSB501-Q1 is driving. This terminal should be pulled low through a resistor to ground or left floating. Figure 8 shows the implementation.

### 10.2.3 Application Curves

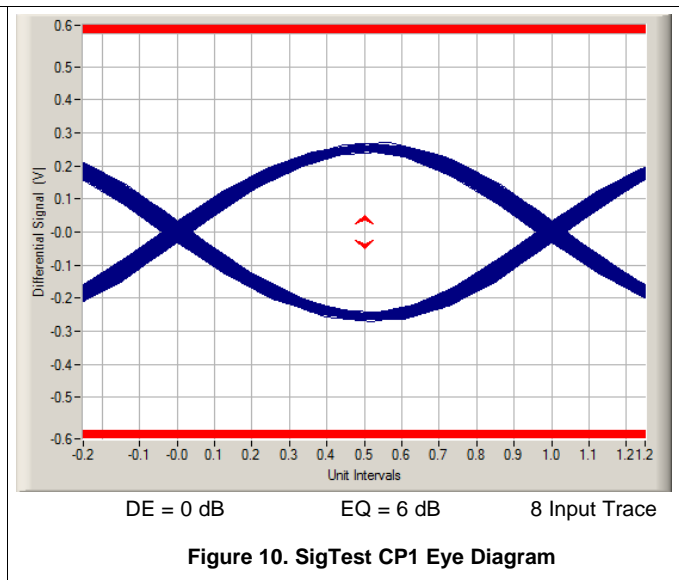
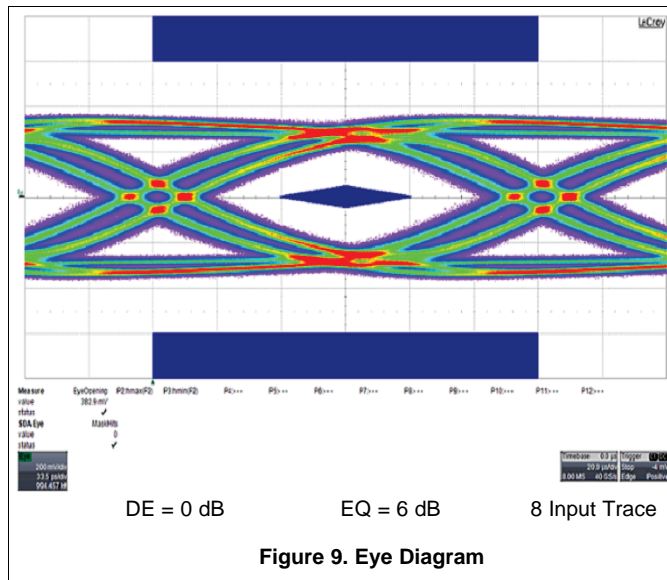

## 11 Power Supply Recommendations

This device is designed to operate with a 3.3-V supply. If using a higher voltage system power supply such as VBUS, a voltage regulator can be used to step down to 3.3 V. Decoupling capacitors may be used to reduce noise and improve power supply integrity.

## 12 Layout

### 12.1 Layout Guidelines

- The 100-nF capacitors on the TXP and SSTXN nets should be placed close to the USB connector (Type A, Type B, and so forth).
- The ESD and EMI protection devices (if used) should also be placed as close as possible to the USB connector.
- Place voltage regulators as far away as possible from the differential pairs.
- In general, the large bulk capacitors associated with each power rail should be placed as close as possible to the voltage regulators.
- It is recommended that small decoupling capacitors for the 1.8-V power rail be placed close to the TUSB501-Q1 as shown in [Figure 11](#).
- The SuperSpeed differential pair traces for RXP/N and TXP/N must be designed with a characteristic impedance of  $90 \Omega \pm 10\%$ . The PCB stack-up and materials determines the width and spacing needed for a characteristic impedance of  $90 \Omega$ .
- The SuperSpeed differential pair traces should be routed parallel to each other as much as possible. It is recommended the traces be symmetrical.
- In order to minimize cross talk, it is recommended to keep high speed signals away from each other. Each pair should be separated by at least 5 times the signal trace width. Separating with ground also helps minimize cross talk.
- Route all differential pairs on the same layer adjacent to a solid ground plane.
- Do not route differential pairs over any plane split.
- Adding test points will cause impedance discontinuity and will therefore negatively impact signal performance. If test points are used, they should be placed in series and symmetrically. They must not be placed in a manner that causes stub on the differential pair.
- Avoid 90 degree turns in traces. The use of bends in differential traces should be kept to a minimum. When bends are used, the number of left and right bends should be as equal as possible and the angle of the bend should be  $\geq 135$  degrees. This will minimize any length mismatch caused by the bends and therefore minimize the impact bends have on EMI.
- Match the etch lengths of the differential pair traces. There should be less than 5 mils difference between a SS differential pair signal and its complement. The USB 2.0 differential pairs should not exceed 50 mils relative trace length difference.
- The etch lengths of the differential pair groups do not need to match (that is, the length of the RXP/N pair to that of the TXP/N pair), but all trace lengths should be minimized.
- Minimize the use of vias in the differential pair paths as much as possible. If this is not practical, make sure that the same via type and placement are used for both signals in a pair. Any vias used should be placed as close as possible to the TUSB501-Q1 device.
- To ease routing, the polarity of the SS differential pairs can be swapped. This means that TXP can be routed to TXN or RXN can be routed to RXP.
- Do not place power fuses across the differential pair traces.

## 12.2 Layout Example

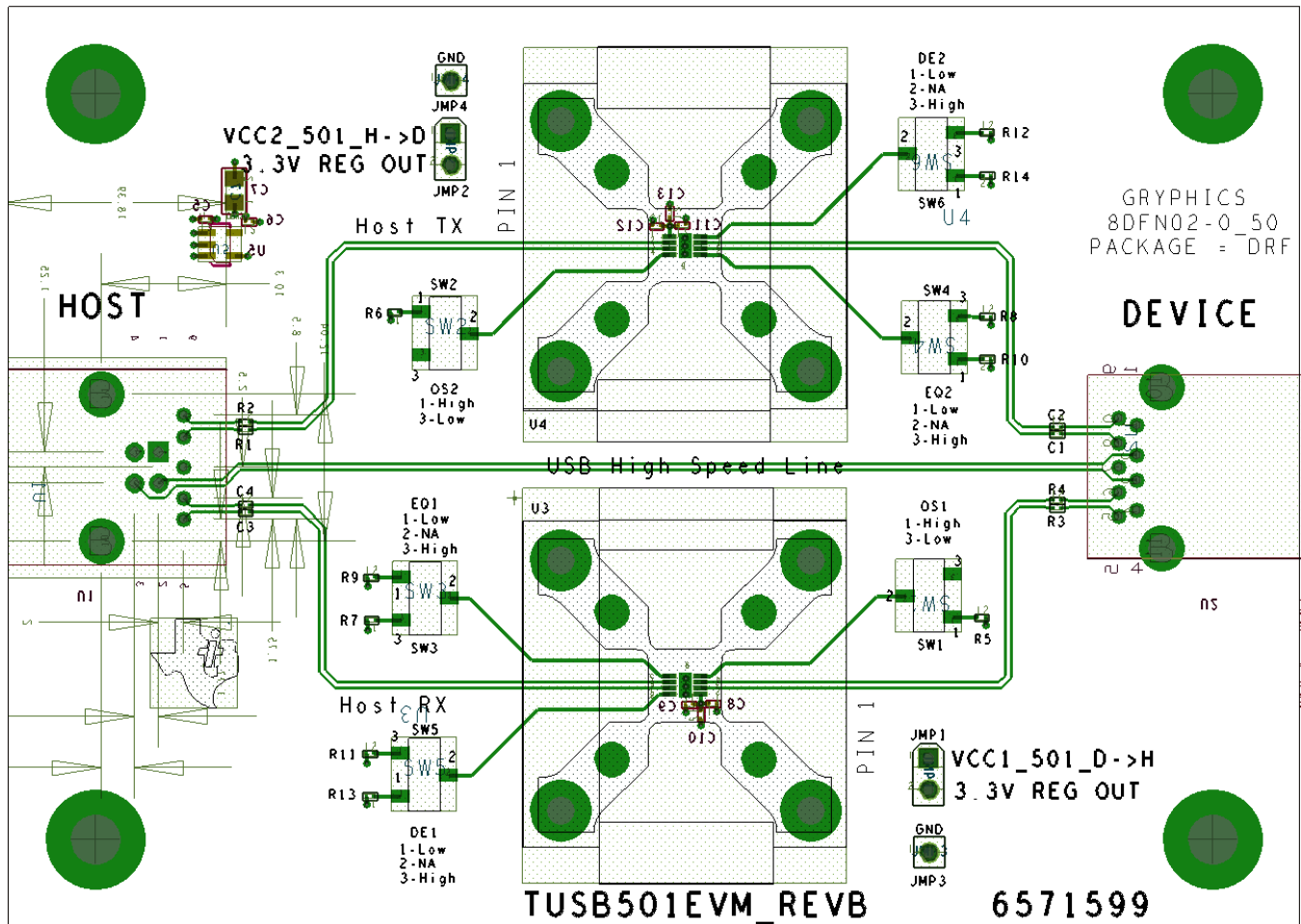

Figure 11. Example Layout

## 13 Device and Documentation Support

### 13.1 Community Resources

The following links connect to TI community resources. Linked contents are provided "AS IS" by the respective contributors. They do not constitute TI specifications and do not necessarily reflect TI's views; see TI's [Terms of Use](#).

**TI E2E™ Online Community** *TI's Engineer-to-Engineer (E2E) Community*. Created to foster collaboration among engineers. At [e2e.ti.com](http://e2e.ti.com), you can ask questions, share knowledge, explore ideas and help solve problems with fellow engineers.

**Design Support** *TI's Design Support* Quickly find helpful E2E forums along with design support tools and contact information for technical support.

### 13.2 Trademarks

E2E is a trademark of Texas Instruments.  
All other trademarks are the property of their respective owners.

### 13.3 Electrostatic Discharge Caution



These devices have limited built-in ESD protection. The leads should be shorted together or the device placed in conductive foam during storage or handling to prevent electrostatic damage to the MOS gates.

### 13.4 Glossary

[SLYZ022](#) — *TI Glossary*.

This glossary lists and explains terms, acronyms, and definitions.

## 14 Mechanical, Packaging, and Orderable Information

The following pages include mechanical, packaging, and orderable information. This information is the most current data available for the designated devices. This data is subject to change without notice and revision of this document. For browser-based versions of this data sheet, refer to the left-hand navigation.

**PACKAGING INFORMATION**

Orderable Device	Status (1)	Package Type	Package Drawing	Pins	Package Qty	Eco Plan (2)	Lead/Ball Finish (6)	MSL Peak Temp (3)	Op Temp (°C)	Device Marking (4/5)	Samples
TUSB501TDRFRQ1	ACTIVE	WSON	DRF	8	3000	Green (RoHS & no Sb/Br)	NIPDAU	Level-2-260C-1 YEAR	-40 to 105	501Q	<a href="#">Samples</a>

(1) The marketing status values are defined as follows:

**ACTIVE:** Product device recommended for new designs.

**LIFEBUY:** TI has announced that the device will be discontinued, and a lifetime-buy period is in effect.

**NRND:** Not recommended for new designs. Device is in production to support existing customers, but TI does not recommend using this part in a new design.

**PREVIEW:** Device has been announced but is not in production. Samples may or may not be available.

**OBSOLETE:** TI has discontinued the production of the device.

(2) **RoHS:** TI defines "RoHS" to mean semiconductor products that are compliant with the current EU RoHS requirements for all 10 RoHS substances, including the requirement that RoHS substance do not exceed 0.1% by weight in homogeneous materials. Where designed to be soldered at high temperatures, "RoHS" products are suitable for use in specified lead-free processes. TI may reference these types of products as "Pb-Free".

**RoHS Exempt:** TI defines "RoHS Exempt" to mean products that contain lead but are compliant with EU RoHS pursuant to a specific EU RoHS exemption.

**Green:** TI defines "Green" to mean the content of Chlorine (Cl) and Bromine (Br) based flame retardants meet JS709B low halogen requirements of <=1000ppm threshold. Antimony trioxide based flame retardants must also meet the <=1000ppm threshold requirement.

(3) MSL, Peak Temp. - The Moisture Sensitivity Level rating according to the JEDEC industry standard classifications, and peak solder temperature.

(4) There may be additional marking, which relates to the logo, the lot trace code information, or the environmental category on the device.

(5) Multiple Device Markings will be inside parentheses. Only one Device Marking contained in parentheses and separated by a "~" will appear on a device. If a line is indented then it is a continuation of the previous line and the two combined represent the entire Device Marking for that device.

(6) Lead/Ball Finish - Orderable Devices may have multiple material finish options. Finish options are separated by a vertical ruled line. Lead/Ball Finish values may wrap to two lines if the finish value exceeds the maximum column width.

**Important Information and Disclaimer:**The information provided on this page represents TI's knowledge and belief as of the date that it is provided. TI bases its knowledge and belief on information provided by third parties, and makes no representation or warranty as to the accuracy of such information. Efforts are underway to better integrate information from third parties. TI has taken and continues to take reasonable steps to provide representative and accurate information but may not have conducted destructive testing or chemical analysis on incoming materials and chemicals. TI and TI suppliers consider certain information to be proprietary, and thus CAS numbers and other limited information may not be available for release.

In no event shall TI's liability arising out of such information exceed the total purchase price of the TI part(s) at issue in this document sold by TI to Customer on an annual basis.

**OTHER QUALIFIED VERSIONS OF TUSB501-Q1 :**

- Catalog: [TUSB501](#)

NOTE: Qualified Version Definitions:

- Catalog - TI's standard catalog product

DRF (S-PWSON-N8)

PLASTIC SMALL OUTLINE NO-LEAD

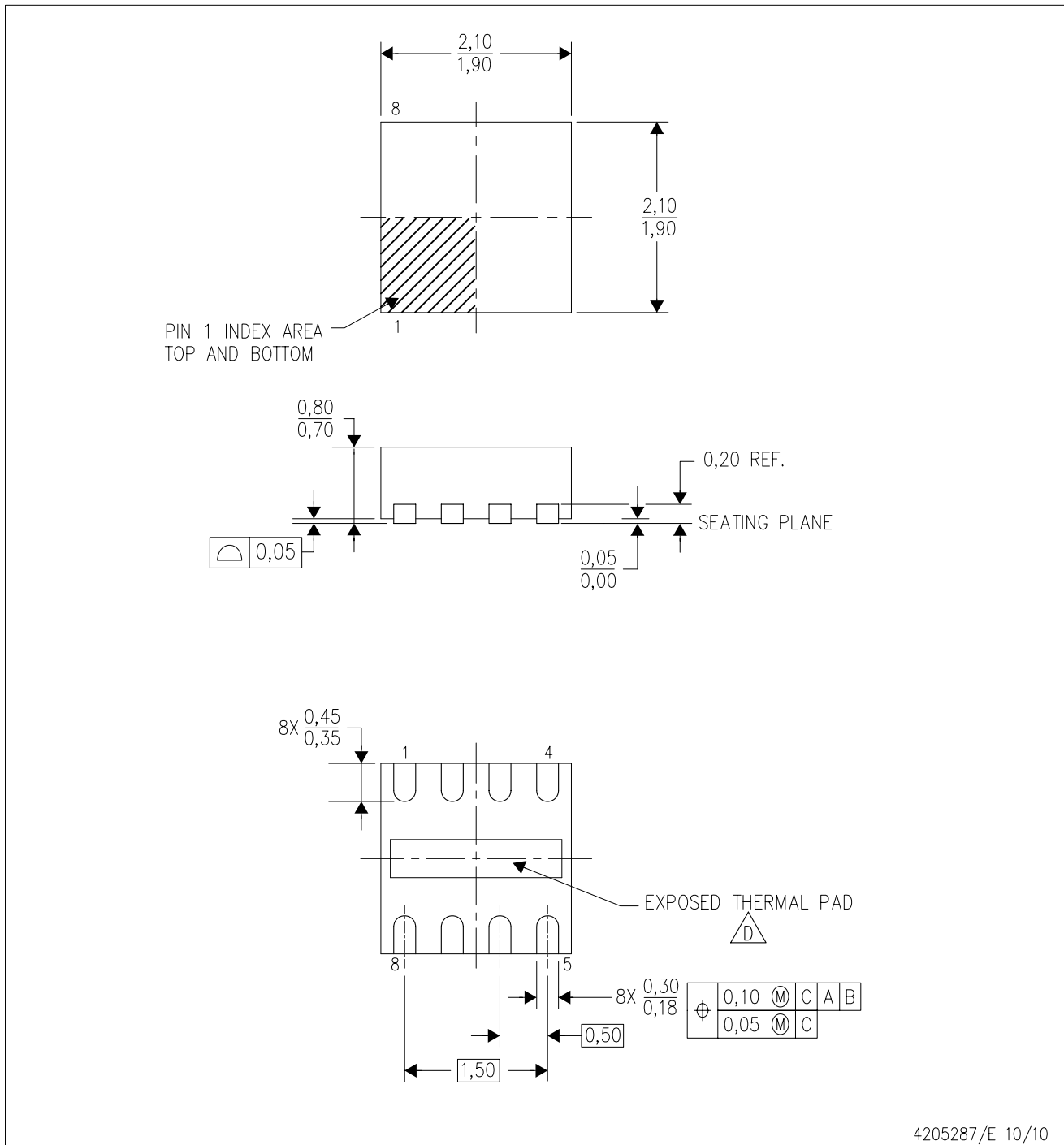

4205287/E 10/10

- NOTES:
- A. All linear dimensions are in millimeters. Dimensioning and tolerancing per ASME Y14.5M-1994.
  - B. This drawing is subject to change without notice.
  - C. Quad Flatpack, No-Leads (QFN) package configuration.
  - D. The Package thermal pad must be soldered to the board for thermal and mechanical performance. See product data sheet for details regarding the exposed thermal pad dimensions.
  - E. Falls within JEDEC MO-229.

# THERMAL PAD MECHANICAL DATA

DRF (S-PWSON-N8)

PLASTIC SMALL OUTLINE NO-LEAD

## THERMAL INFORMATION

This package incorporates an exposed thermal pad that is designed to be attached directly to an external heatsink. The thermal pad must be soldered directly to the printed circuit board (PCB). After soldering, the PCB can be used as a heatsink. In addition, through the use of thermal vias, the thermal pad can be attached directly to the appropriate copper plane shown in the electrical schematic for the device, or alternatively, can be attached to a special heatsink structure designed into the PCB. This design optimizes the heat transfer from the integrated circuit (IC).

For information on the Quad Flatpack No-Lead (QFN) package and its advantages, refer to Application Report, QFN/SOIC PCB Attachment, Texas Instruments Literature No. SLUA271. This document is available at [www.ti.com](http://www.ti.com).

The exposed thermal pad dimensions for this package are shown in the following illustration.

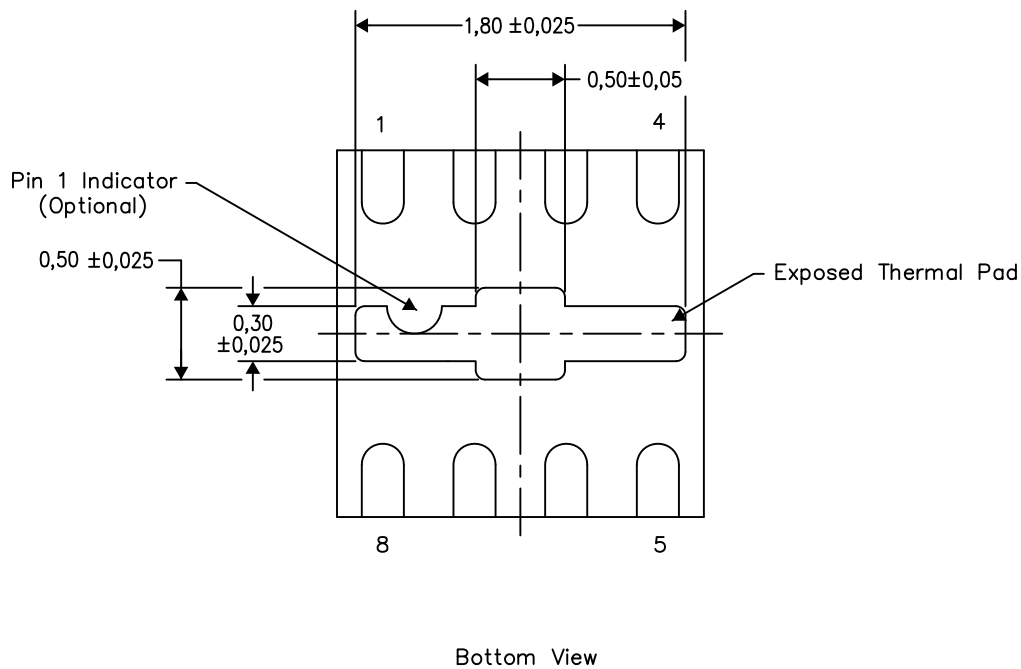

Exposed Thermal Pad Dimensions

4206840/H 12/14

NOTE: A. All linear dimensions are in millimeters

DRF (S-PWSON-N8)

PLASTIC SMALL OUTLINE NO-LEAD

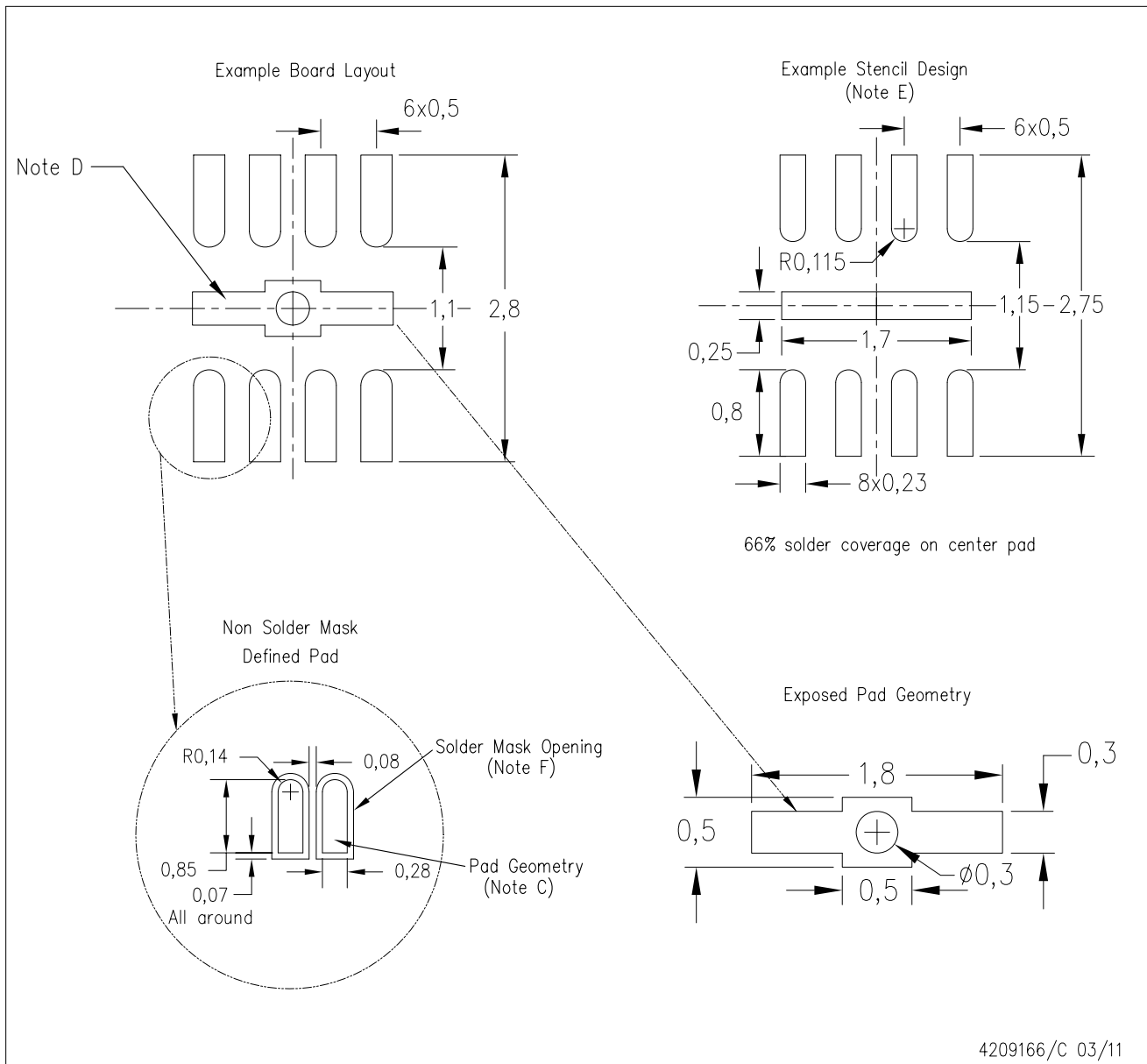

- NOTES:
- All linear dimensions are in millimeters.
  - This drawing is subject to change without notice.
  - Publication IPC-7351 is recommended for alternate designs.
  - This package is designed to be soldered to a thermal pad on the board. Refer to Application Note, Quad Flat-Pack Packages, Texas Instruments Literature No. SLUA271, and also the Product Data Sheets for specific thermal information, via requirements, and recommended board layout. These documents are available at [www.ti.com](http://www.ti.com) <<http://www.ti.com>>.
  - Laser cutting apertures with trapezoidal walls and also rounding corners will offer better paste release. Customers should contact their board assembly site for stencil design recommendations. Refer to IPC 7525 for stencil design considerations.
  - Customers should contact their board fabrication site for minimum solder mask web tolerances between signal pads.

## IMPORTANT NOTICE AND DISCLAIMER

TI PROVIDES TECHNICAL AND RELIABILITY DATA (INCLUDING DATASHEETS), DESIGN RESOURCES (INCLUDING REFERENCE DESIGNS), APPLICATION OR OTHER DESIGN ADVICE, WEB TOOLS, SAFETY INFORMATION, AND OTHER RESOURCES "AS IS" AND WITH ALL FAULTS, AND DISCLAIMS ALL WARRANTIES, EXPRESS AND IMPLIED, INCLUDING WITHOUT LIMITATION ANY IMPLIED WARRANTIES OF MERCHANTABILITY, FITNESS FOR A PARTICULAR PURPOSE OR NON-INFRINGEMENT OF THIRD PARTY INTELLECTUAL PROPERTY RIGHTS.

These resources are intended for skilled developers designing with TI products. You are solely responsible for (1) selecting the appropriate TI products for your application, (2) designing, validating and testing your application, and (3) ensuring your application meets applicable standards, and any other safety, security, or other requirements. These resources are subject to change without notice. TI grants you permission to use these resources only for development of an application that uses the TI products described in the resource. Other reproduction and display of these resources is prohibited. No license is granted to any other TI intellectual property right or to any third party intellectual property right. TI disclaims responsibility for, and you will fully indemnify TI and its representatives against, any claims, damages, costs, losses, and liabilities arising out of your use of these resources.

TI's products are provided subject to TI's Terms of Sale ([www.ti.com/legal/termsofsale.html](http://www.ti.com/legal/termsofsale.html)) or other applicable terms available either on [ti.com](http://ti.com) or provided in conjunction with such TI products. TI's provision of these resources does not expand or otherwise alter TI's applicable warranties or warranty disclaimers for TI products.

Mailing Address: Texas Instruments, Post Office Box 655303, Dallas, Texas 75265  
Copyright © 2020, Texas Instruments Incorporated