

A	RevA	Embest	14-Oct-15			
A	INIT EDIT					
REV	MODIF.	DES.	DATE	VER.	DATE	
SAME70-XPLD		SCALE	1/1		REV.	SHEET
TOP				A	1/4	

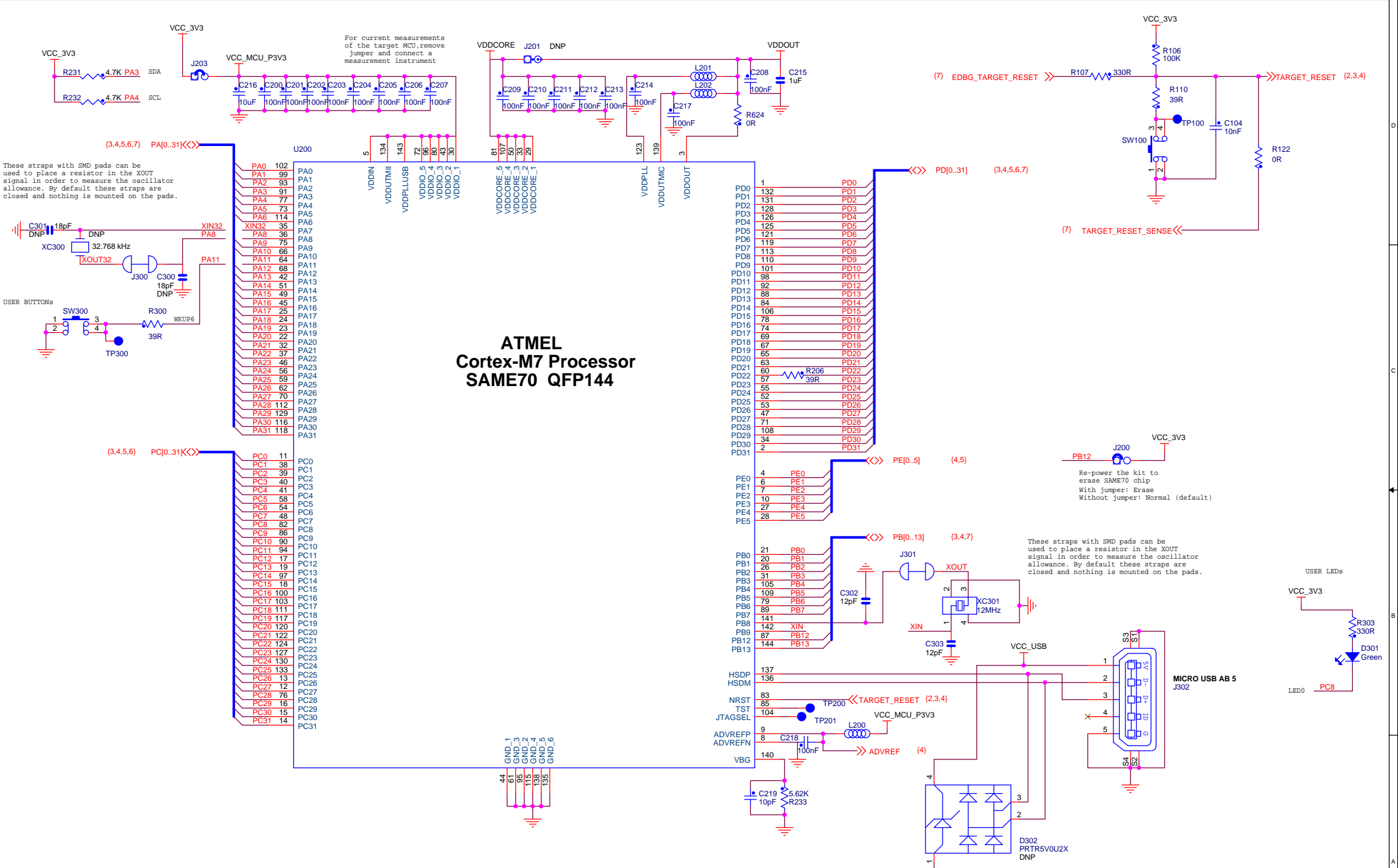

**ATMEL  
Cortex-M7 Processor  
SAME70 QFP144**

These straps with SMD pads can be used to place a resistor in the XOUT signal in order to measure the oscillator allowance. By default these straps are closed and nothing is mounted on the pads.

These straps with SMD pads can be used to place a resistor in the XOUT signal in order to measure the oscillator allowance. By default these straps are closed and nothing is mounted on the pads.

Re-power the kit to erase SAME70 chip  
With jumper: Erase  
Without jumper: Normal (default)

Re-power the kit to erase SAME70 chip  
With jumper: Erase  
Without jumper: Normal (default)

Atmel		RevA	Embest	14-Oct-15		
		SCALE 1/1			REV. A	SHEET 2/7
SAME70-XPLD		REV. MODIF.	DES.	DATE	VER.	DATE
SAME70						

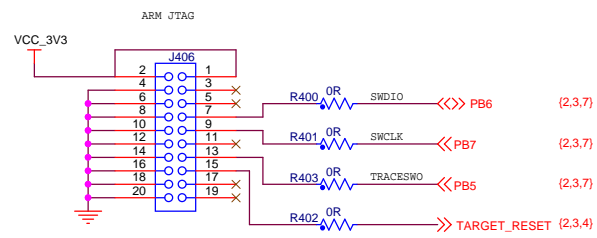
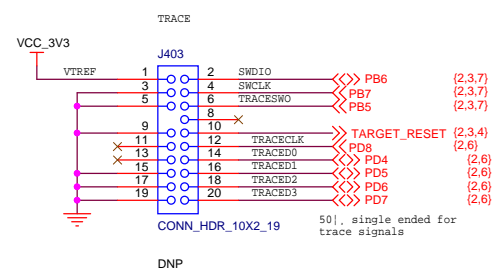
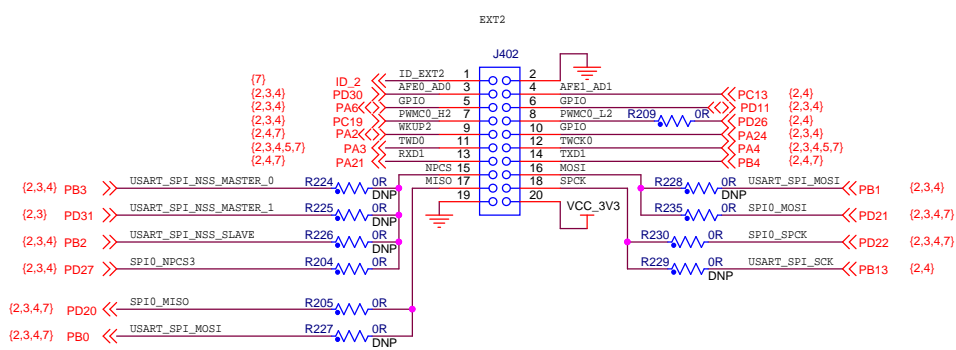
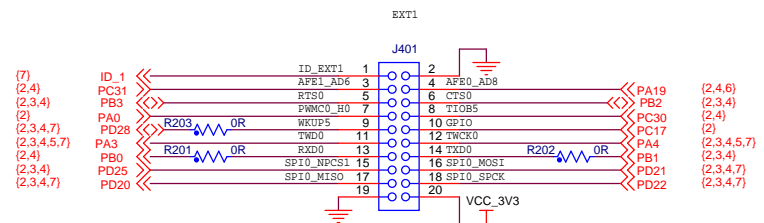
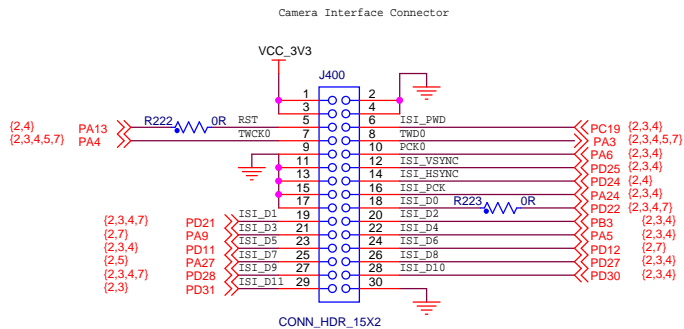

Atmel		RevA		Embest 14-Oct-15	
SAME70-XPLD		SCALE	1/1	REV.	A
Extension Connectors		SHEET		3/7	

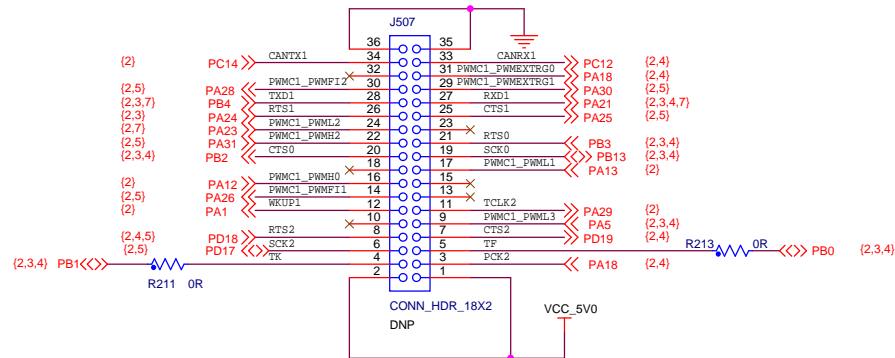
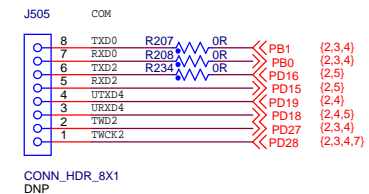
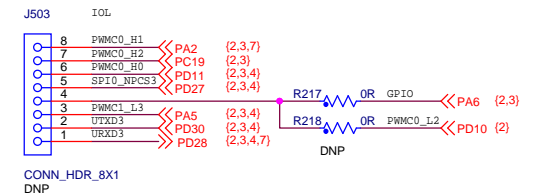
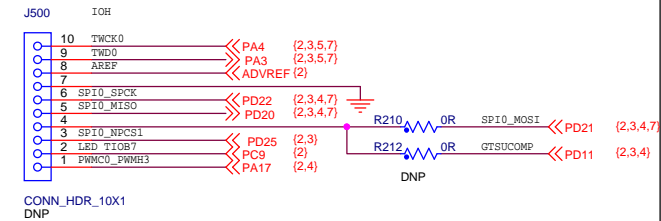
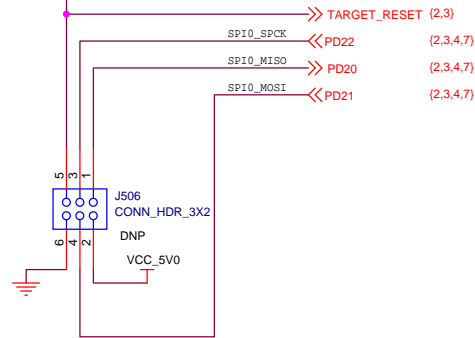
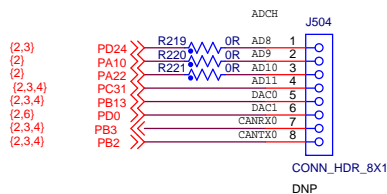
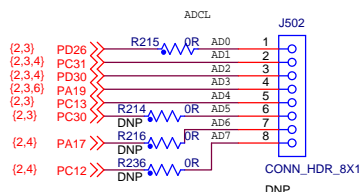
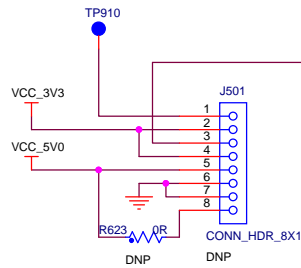

Atmel		RevA	Embest	14-Oct-15		
		INIT EDIT				
SAME70-XPLD		SCALE	1/1		REV. A	SHEET 4/7
Shield Connectors						

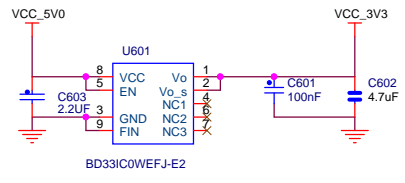
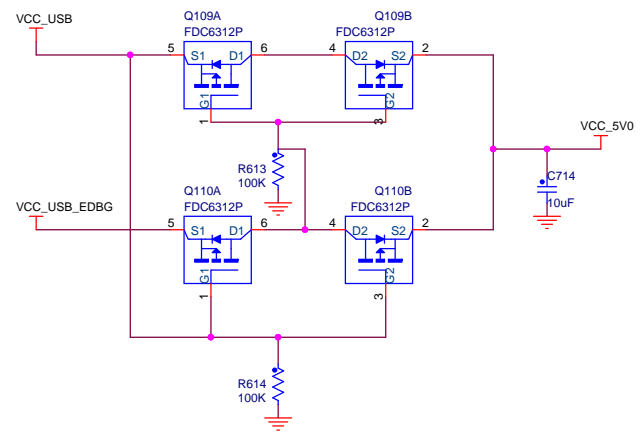
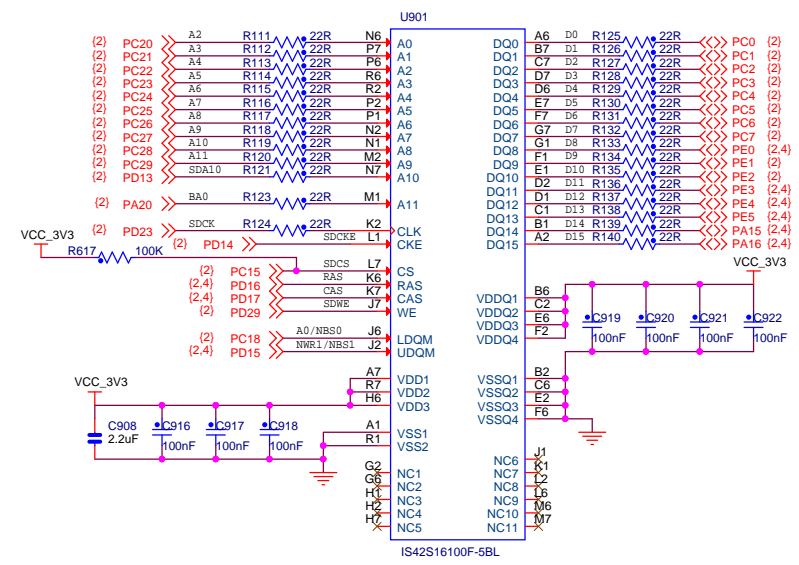
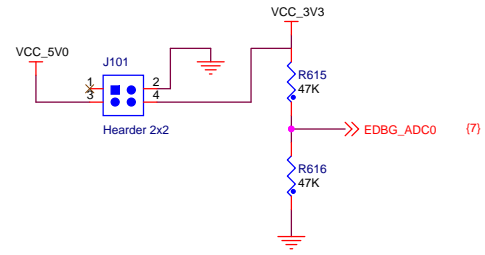
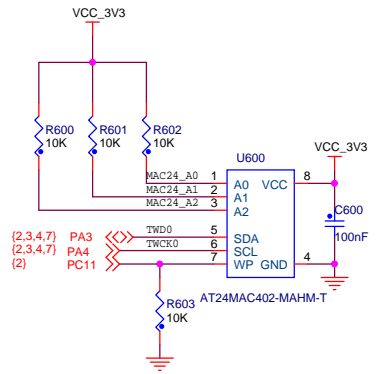
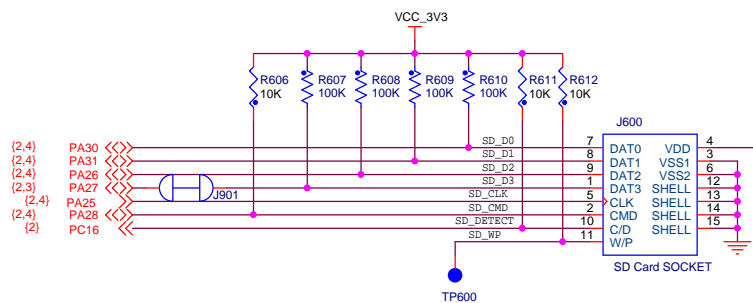

Atmel		RevA	Embest	14-Oct-15		
		INIT	EDIT			
SAME70-XPLD		SCALE	1/1	REV.	A	SHEET
Memory & Power						5/7

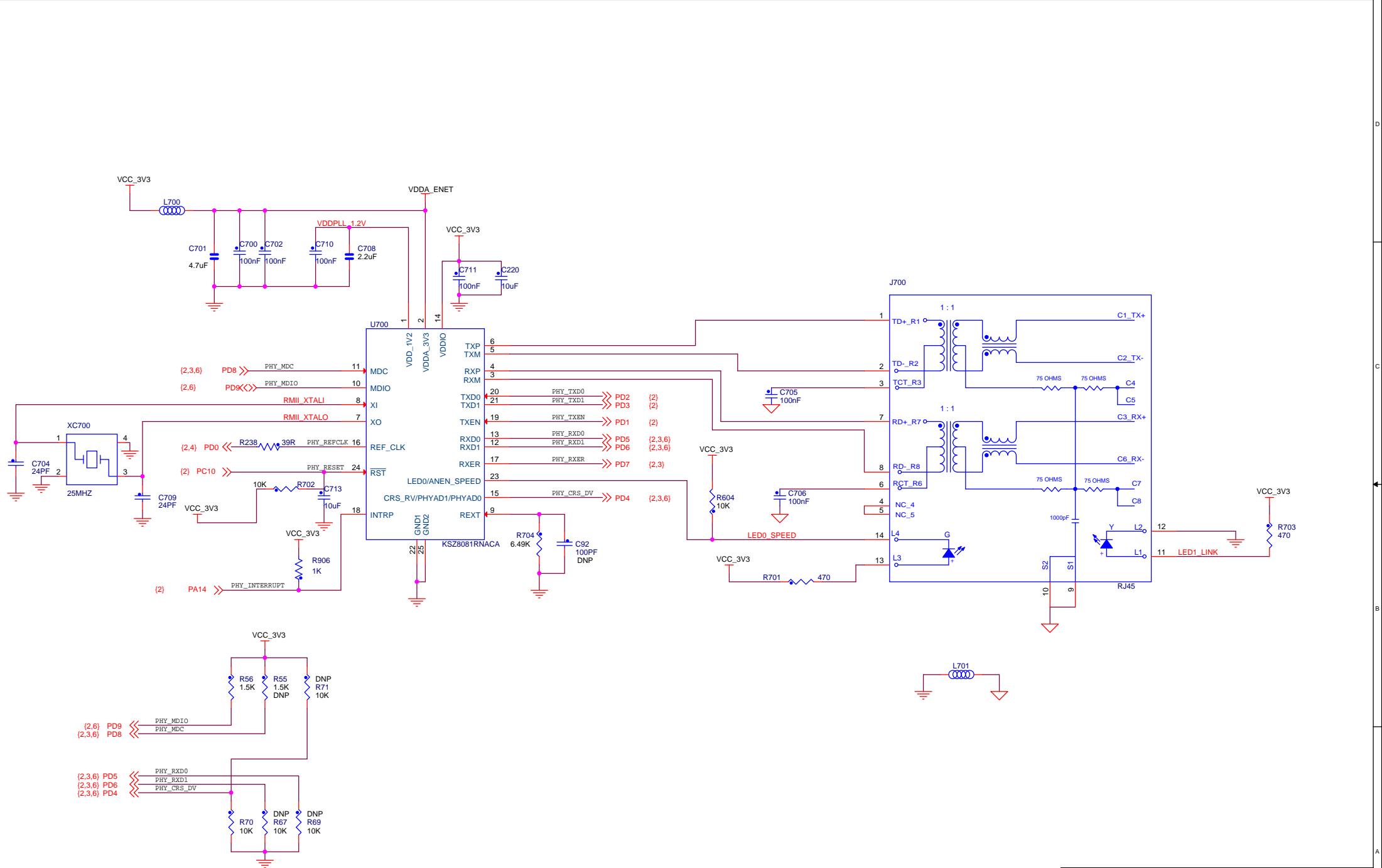

		RevA	Embrest	14-Oct-15		
		INIT	EDIT			
SAME70-XPLD		SCALE	1/1		REV.	DATE
Ethernet				REV.	SHEET <b>A</b> / <b>6</b>	

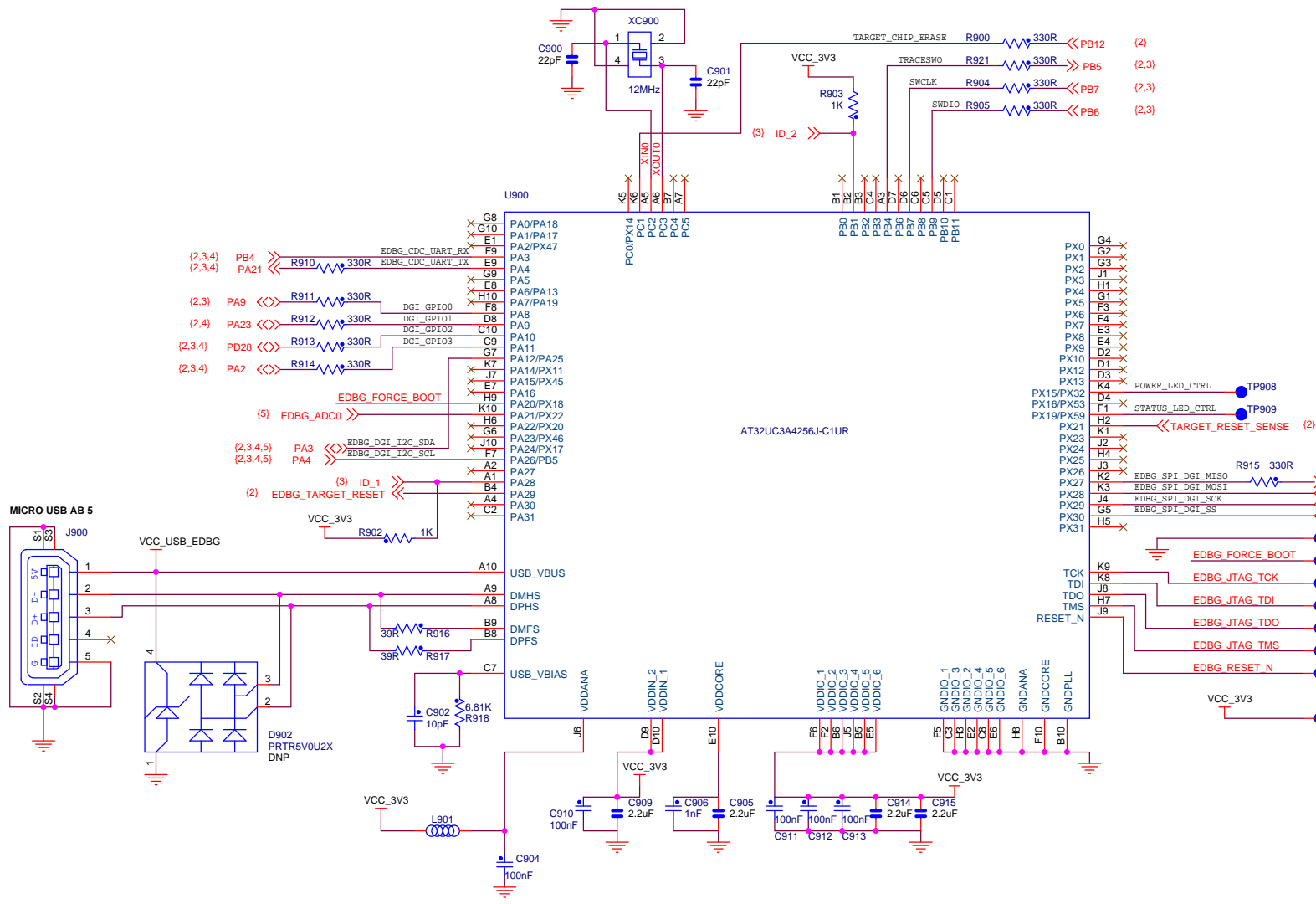

Connect TP900 to TP901 during startup of the EDBG to force it into bootloader mode

		RevA		Embest 14-Oct-15	
		INIT	EDIT	DES.	DATE
SAME70-XPLD		SCALE	1/1	REV.	DATE
Embedded Debugger				A	7/7