

Cascadable Thin Film Amplifier, 28 dB Gain, 5 - 1000 MHz

AM-182

Features

- 28.5 dB Typical Gain
- 2.7 dB Typical Low Noise

Description

M/A-COM's AM-182 is a high gain feedback amplifier with high intercept and compression points. This amplifier is packaged in a TO-8 package. Due to the internal power dissipation the thermal rise should be minimized. The ground plane on the PC board should be configured to remove heat from under the package. AM-182 is ideally suited for use where a high intercept, high reliability amplifier is required.

C-32

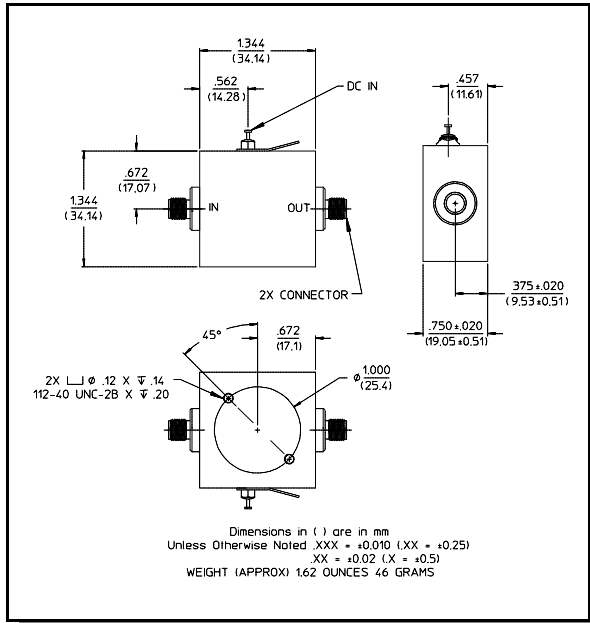

TO-8-1

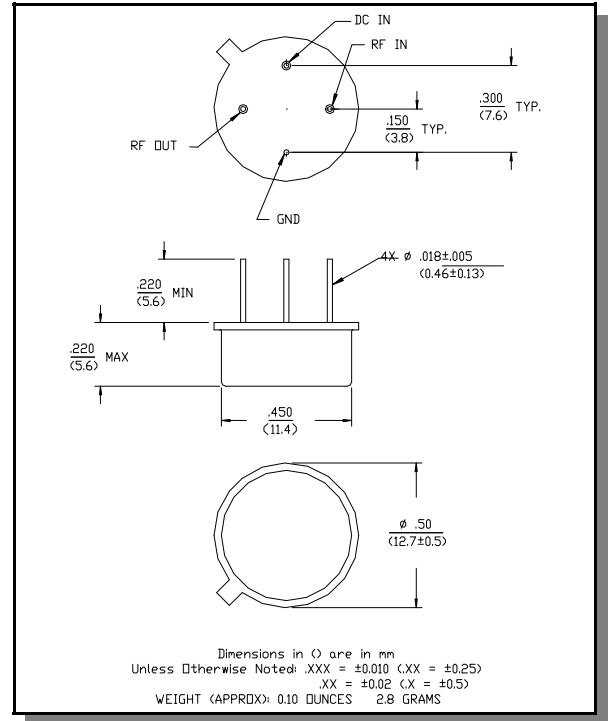

Absolute Maximum Ratings ¹

Parameter	Absolute Maximum
Max Input Power	+13 dBm
Vbias	+15.75 V
Operating Temperature	-55°C to +85°C
Storage Temperature	-65°C to +125°C

1. Operation of this device above any one of these parameters may cause permanent damage.

Electrical Specifications ^{2,3} $T_A = -55^{\circ}\text{C}$ to $+85^{\circ}\text{C}$ Case Temperature

Parameter	Test Conditions	Frequency	Units	Min.	Typ.	Max.
Gain	@ +25°C	300 MHz	dB	27.2	28.2	29.2
Frequency Response	—	5 - 1000 MHz	dB	—	—	±1.2
Gain Variation with Temperature	—	5 - 1000 MHz	dB	—	—	±1.2
1 dB Compression	Output Power	5 - 1000 MHz	dBm	+9	—	—
Noise Figure	—	5 - 1000 MHz	dB	—	—	4.5
Reverse Transmission	—	5 - 1000 MHz	dB	—	-36	-32
VSWR	—	5 - 1000 MHz	Ratio	—	—	2.0:1
Output IP ₂	Two-tone inputs up to 0 dBm	5 - 1000 MHz	dBm	+28	—	—
Output IP ₃	Two-tone inputs up to 0 dBm	5 - 1000 MHz	dBm	+18	—	—
Vbias	—	—	V	+14.5	+15.0	+15.5
Ibias	Vbias = +15.0 VDC	—	mA	—	44	50
Power Dissipation	@ +15V Bias	—	mW	—	660	—

2. All specifications apply when operated at +15 VDC, with 50 ohms source and load impedance.

3. Heat Sinking: Operation at case temperature above 95°C is not recommended. Heat sinking adequate to dissipate 800 mW must be provided in use.

Specifications subject to change without notice.

- North America: Tel. (800) 366-2266
- Asia/Pacific: Tel.+81-44-844-8296, Fax +81-44-844-8298
- Europe: Tel. +44 (1344) 869 595, Fax+44 (1344) 300 020

Visit www.macom.com for additional data sheets and product information.

tyco / Electronics

MACOM

Typical Performance Curves

Gain vs. Frequency

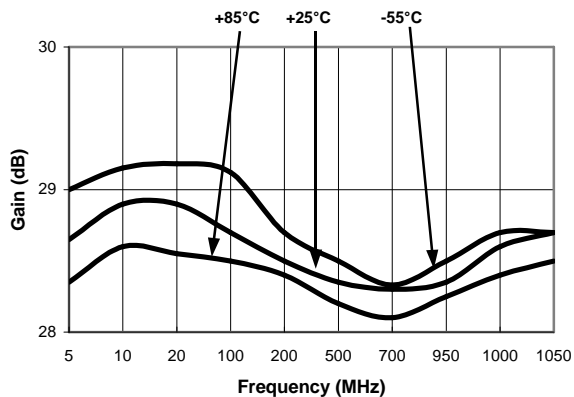

VSWR vs. Frequency

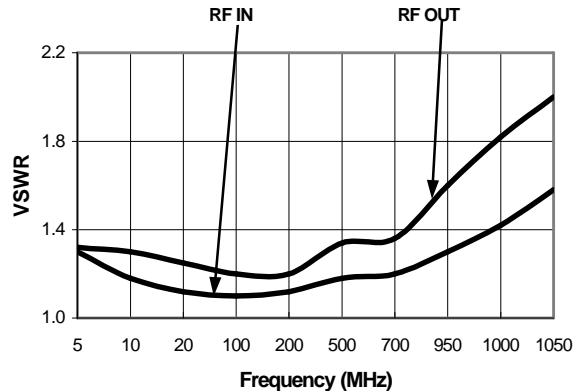

Noise Figure

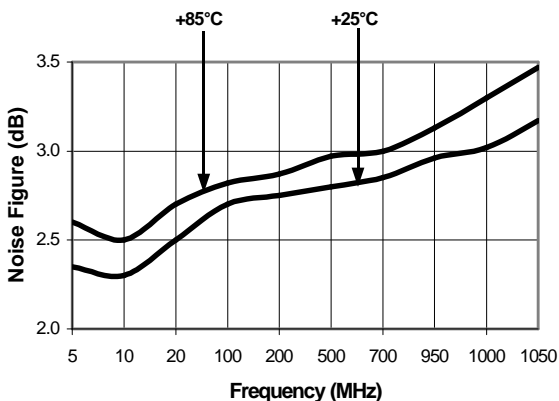

1 dB Compression

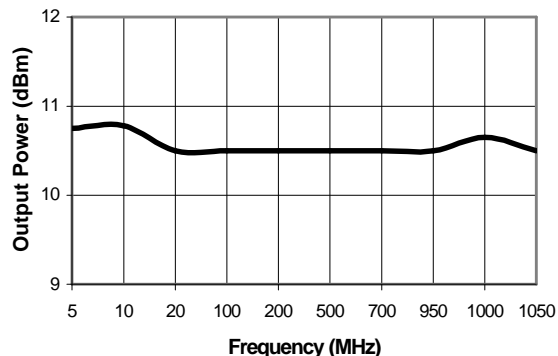

Intermodulation Intercept

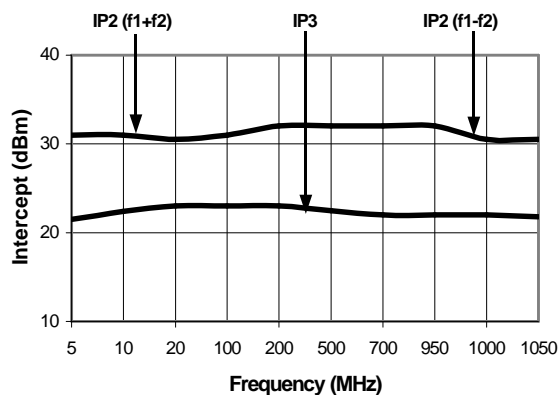

Ordering Information

Part Number	Package
AM-182 PIN	TO-8-1
AMC-182 SMA	C-32

Specifications subject to change without notice.

- North America: Tel. (800) 366-2266
- Asia/Pacific: Tel. +81-44-844-8296, Fax +81-44-844-8298
- Europe: Tel. +44 (1344) 869 595, Fax +44 (1344) 300 020

Visit www.macom.com for additional data sheets and product information.