

Remote I/O R1X Series

THERMOCOUPLE & DC INPUT MODULE

(16 points; CC-Link Ver.1.10/Ver.2.00)

Functions & Features

- 16-point thermocouple or DC inputs
- CC-Link interface
- CC-Link Version 1.10 and 2.00 can be switched at the startup

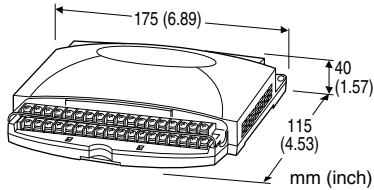

MODEL: R1C-GH2T-[1][2]

ORDERING INFORMATION

- Code number: R1C-GH2T-[1][2]
- Specify a code from below for each [1] and [2].
(e.g. R1C-GH2T-M2/Q)
- Specify the specification for option code /Q
(e.g. /C01)
 - Use Ordering Information Sheet (No. ESU-5956). Default setting will be used if not otherwise specified.

Factory default setting

Input type: DC Voltage ± 5 V
Burnout protection: No burnout
Cold junction compensation: No

FIELD TERMINAL TYPE

T: M3 screw terminals

[1] POWER INPUT

AC Power

M2: 100 - 240 V AC (Operational voltage range 85 - 264 V, 47 - 66 Hz)

DC Power

R: 24 V DC
(Operational voltage range 24 V ± 10 %, ripple 10 %p-p max.)

[2] OPTIONS

blank: none

/Q: With options (specify the specification)

SPECIFICATIONS OF OPTION: Q

COATING (For the detail, refer to M-System's web site.)

/C01: Silicone coating

/C02: Polyurethane coating

/C03: Rubber coating

RELATED PRODUCTS

- Resistor module (model: REM3-250)
- R1X configurator software (model: R1CON)

Downloadable at M-System's web site.

A dedicated cable is required to connect the module to the PC. Please refer to the internet software download site or the users manual for the PC configurator for applicable cable types.

PACKAGE INCLUDES...

- Terminating resistor (110 Ω , 0.5 W)

GENERAL SPECIFICATIONS

Connection

Power input, CC-Link: Euro type connector terminal (applicable wire size: 0.2 to 2.5 mm² (AWG24 to 12), stripped length 7 mm)

Input: M3 screw terminals (torque 0.6 N·m)

Configurator: 2.5 dia. miniature jack; RS-232-C level

Screw terminal: Nickel-plated steel

Housing material: Flame-resistant resin (gray)

Isolation: Input to CC-Link (FG) to power

PWR indicator: Green LED blinks in normal conditions.

CC-Link COMMUNICATION

Protocol: CC-Link V1.10 / V 2.00

Cable for comm. link: Specified by Mitsubishi Electric

Required nodes

V. 1.10: 4

V. 2.00: 1 (cyclic expansion: 4)

Station No. setting: Rotary switch

V. 1.10: Rotary switch; 1 - 61

V. 2.00: Rotary switch; 1 - 64

Baud rate setting: Rotary switch

L RUN indicator: Red LED turns on in normal conditions.

L ERR. indicator: Red LED turns on or blinks in an abnormality.

SD indicator: Red LED turns on when transmitting.

RD indicator: Red LED turns on when receiving.

INPUT SPECIFICATIONS

■ Thermocouple or DC input, 16 points

(Common negative for DC input)

- Measuring range ± 20 V, ± 5 V, ± 1 V: Atten. SW ON (3)

•Measuring range ± 0.8 V, ± 0.2 V, ± 50 mV, ± 10 mV: Atten. SW OFF (1)

Input resistance: 300 k Ω

Thermocouple types: PR, K, E, J, T, B, R, S, C, N, U, L, P

Sampling rate: 150 millise./16 points

■ **A/D conversion output:** 16-bit signed binary (negative range represented by 2's complements)

Engineering unit value is converted into A/D conversion data as shown below.

Input type & range: A/D data (decimal)

± 20 V: ± 20000

± 5 V: ± 5000

± 1 V: ± 10000

± 0.8 V: ± 8000

± 0.2 V: ± 20000

± 50 mV: ± 5000

± 10 mV: ± 10000

Thermocouples: Temperature $\times 10$

In order to change input type and range after shipment, the R1X configurator software (model: R1CON) is required.

CC-Link version selector input:

Ver. 1.10 with OFF at the startup.

Ver. 2.00 with ON at the startup.

Dry contact input (ON at detect. level ≤ 1.5 V)

Sensing: approx. 5 V DC, 1 mA

Valid only at the moment of the power supplied to the module. Firmware version 0B.00 or higher required.

Confirm the firmware version using the R1X configurator software (model: R1CON) or consult M-System.

■ A/D CONVERSION DATA

	15	14	13	12	11	10	9	8	7	6	5	4	3	2	1	0
RWr n+0	SIGN BIT		INPUT 1 A/D CONVERSION DATA													
RWr n+1	SIGN BIT		INPUT 2 A/D CONVERSION DATA													
RWr n+2	SIGN BIT		INPUT 3 A/D CONVERSION DATA													
RWr n+3	SIGN BIT		INPUT 4 A/D CONVERSION DATA													
⋮	⋮		⋮													
⋮	⋮		⋮													
RWr n+7	SIGN BIT		INPUT 8 A/D CONVERSION DATA													
⋮	⋮		⋮													
⋮	⋮		⋮													
RWr n+11	SIGN BIT		INPUT 12 A/D CONVERSION DATA													
⋮	⋮		⋮													
⋮	⋮		⋮													
RWr n+15	SIGN BIT		INPUT 16 A/D CONVERSION DATA													

INSTALLATION

Power consumption

•AC: Approx. 10 VA

•DC: Approx. 7 W

Operating temperature: -5 to +60°C (23 to 140°F)

Operating humidity: 30 to 90 %RH (non-condensing)

Mounting: Surface or DIN rail

Weight: 400 g (0.88 lb)

PERFORMANCE (% of measuring range)

Accuracy

DC input: ± 0.3 %

Thermocouple input: See the table on the end of this section.

Cold junction compensation error: $\pm 3^\circ\text{C}$ or $\pm 5.4^\circ\text{F}$ max. (at $20^\circ\text{C} \pm 10^\circ\text{C}$ or $68^\circ\text{F} \pm 18^\circ\text{F}$)

Temp. coefficient: ± 0.015 %/°C (± 0.008 %/°F)

± 0.05 %/°C (± 0.03 %/°F) for 10 mV range and T/C B (RH)

Insulation resistance: ≥ 100 M Ω with 500 V DC

Dielectric strength: 2000 V AC @ 1 minute (input to CC-Link [FG] to power to ground [FG1])

Thermocouple Accuracy

T/C	USABLE RANGE (°C)	ACCURACY (%)	CONFORMANCE RANGE (°C)
(PR)	0 to 1770	± 0.5	400 to 1770
K (CA)	-270 to +1370	± 0.3	0 to 1370
E (CRC)	-270 to +1000	± 0.7	0 to 1000
J (IC)	-210 to +1200	± 0.7	0 to 1200
T (CC)	-270 to +400	± 1.0	0 to 400
B (RH)	100 to 1820	± 0.7	700 to 1820
R	-50 to +1760	± 0.7	400 to 1760
S	-50 to +1760	± 0.7	400 to 1760
C (WRe 5-26)	0 to 2320	± 0.7	0 to 2320
N	-270 to +1300	± 0.5	0 to 1300
U	-200 to +600	± 0.5	0 to 600
L	-200 to +900	± 0.3	0 to 900
P (Platinel II)	0 to 1395	± 0.5	0 to 1395

T/C	USABLE RANGE (°F)	ACCURACY (%)	CONFORMANCE RANGE (°F)
(PR)	32 to 3218	± 0.5	752 to 3218
K (CA)	-454 to +2498	± 0.3	32 to 2498
E (CRC)	-454 to +1832	± 0.7	32 to 1832
J (IC)	-346 to +2192	± 0.7	32 to 2192
T (CC)	-454 to +752	± 1.0	32 to 752
B (RH)	212 to 3308	± 0.7	1292 to 3308
R	-58 to +3200	± 0.7	752 to 3200
S	-58 to +3200	± 0.7	752 to 3200
C (WRe 5-26)	32 to 4208	± 0.7	32 to 4208
N	-454 to +2372	± 0.5	32 to 2372
U	-328 to +1112	± 0.5	32 to 1112
L	-328 to +1652	± 0.3	32 to 1652
P (Platinel II)	32 to 1395	± 0.5	32 to 1395

Note: CJC error is not included.

EXTERNAL VIEW

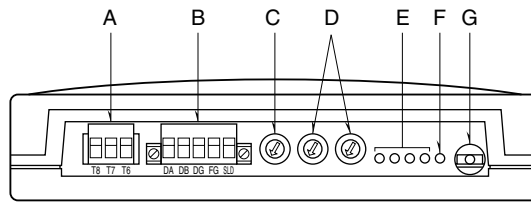

	NAME	FUNCTIONS	
A	Power terminal block	For power input	
B	Network terminal block	For wiring to CC-Link	
C	Baud rate setting	SETTING	BAUD RATE
		0	156 kbps (factory default)
		1	625 kbps
		2	2.5 Mbps
		3	5 Mbps
4	10 Mbps		
Other than 0 – 4	Not valid; L ERR. turns on as a transmission error.		
D	Station No. setting	V. 1.10: Selectable within 1 – 61. (factory set to: 00) V. 2.00: Selectable within 1 – 64. (factory set to: 00)	
E	Status indicator LED	ID (color)	FUNCTIONS
		L RUN. (red)	ON: Normal communication blinking: Transmission data error OFF: Communication down (time-out error)
		L ERR. (red)	ON: Transmission data error blinking: Transmission data error OFF: Normal transmission
		SD (red)	ON when transmitting
RD (red)	ON when receiving		
F	Power LED	ID (color)	FUNCTIONS
		PWR (green)	ON: Abnormality blinking, high speed: CC-Link Ver. 1.10 blinking, low speed: CC-Link Ver. 2.00 Master Version 2.00 with long ON time Master Version 1.10 with long OFF time
G	Configurator jack	2.5 dia. miniature jack; RS-232-C level	

CONNECTION DIAGRAM

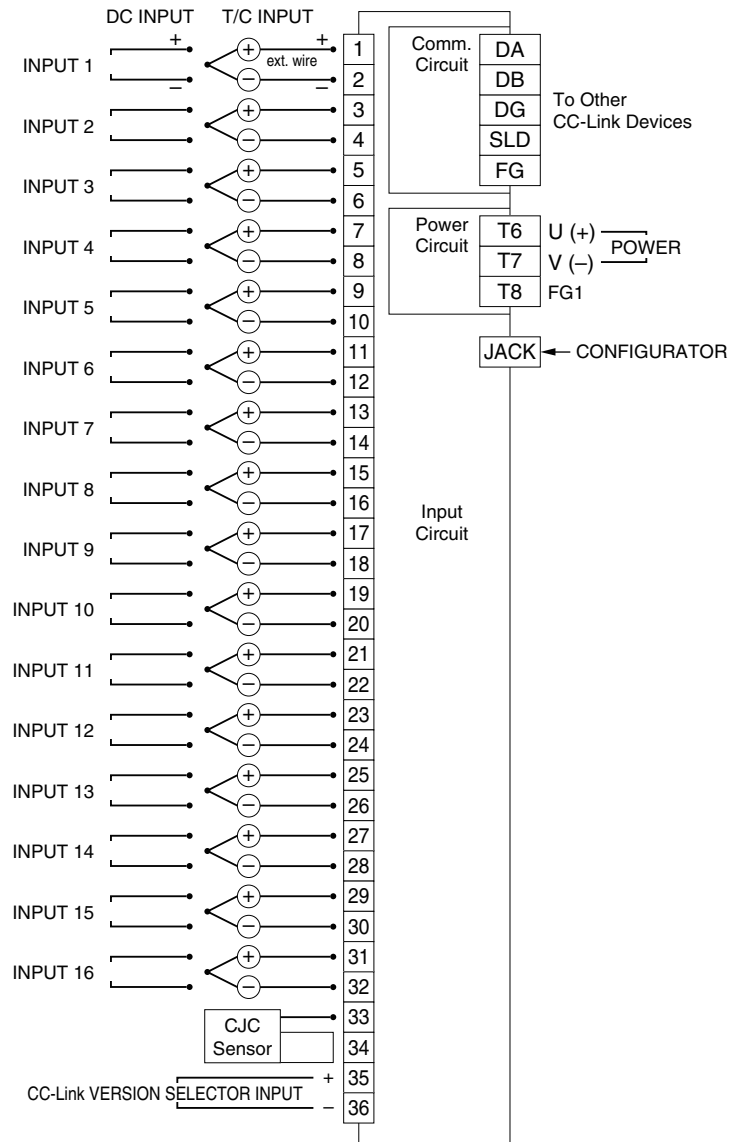

Note 1: This device is not designed to cancel noise included in the input signals.

Be careful to eliminate such noise by using shielded cables.

Note 2: Be sure to maintain the same potential at all the common negative terminals for DC input.

Note 3: CC-Link version selector input is valid only at the moment of the power turned on.

Firmware version 0B.00 or higher. Use the R1X Configurator Software (model: R1CON) or consult M-System to confirm the firmware version.

Caution: FG1 terminal is NOT a protective conductor terminal.

EXTERNAL DIMENSIONS & TERMINAL ASSIGNMENTS unit: mm (inch)

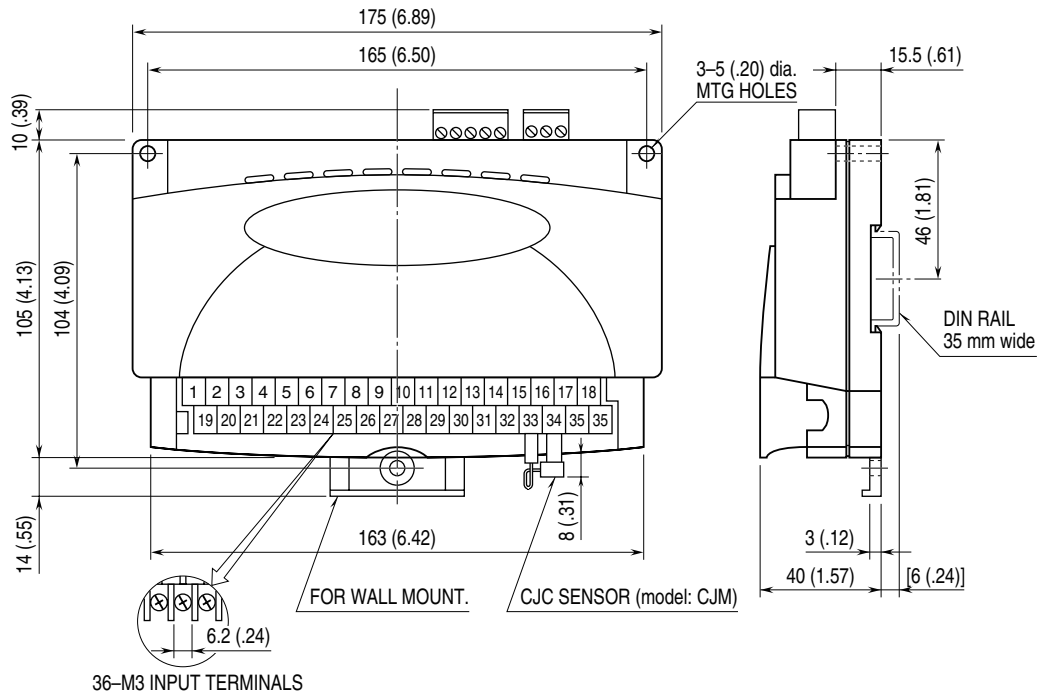

Specifications are subject to change without notice.