

**RoHS Compliant & Pb-Free Product**

Typical Applications

- 2.14GHz UMTS Systems
- Digital Communication Systems
- PCS Communication Systems
- Commercial and Consumer Systems

Product Description

The RF5187 is a highly-linear, low-power amplifier IC. It has been designed for use as the driver RF amplifier in applications such as W-CDMA basestations. The RF5187 requires an input and output matching network and power supply feed line. The device is manufactured on an advanced Gallium Arsenide HBT process, and is packaged in a 8-pin plastic package with a backside ground.

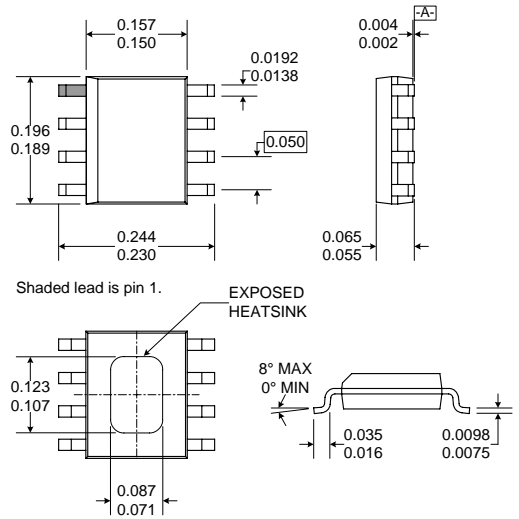

Optimum Technology Matching® Applied

- |                                     |  |                                       |
|-------------------------------------|--|---------------------------------------|
| <input type="checkbox"/> Si BJT     | <input checked="" type="checkbox"/> GaAs HBT | <input type="checkbox"/> GaAs MESFET  |
| <input type="checkbox"/> Si Bi-CMOS | <input type="checkbox"/> SiGe HBT            | <input type="checkbox"/> Si CMOS      |
| <input type="checkbox"/> InGaP/HBT  | <input type="checkbox"/> GaN HEMT            | <input type="checkbox"/> SiGe Bi-CMOS |

Package Style: SOIC-8 Slug

- Features**
- Single 3V to 6V Supply
  - 10dBm to 20dBm Ultra Linear Output Power
  - 14dB Gain at 2.14GHz
  - Power Down Mode
  - 800MHz to 2500MHz Operation

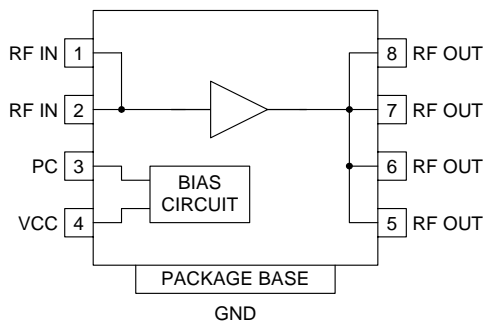

Functional Block Diagram

**Ordering Information**

RF5187 Low Power Linear Amplifier  
 RF5187PCBA-41X Fully Assembled Evaluation Board

RF Micro Devices, Inc.  
 7628 Thorndike Road  
 Greensboro, NC 27409, USA

Tel (336) 664 1233  
 Fax (336) 664 0454  
<http://www.rfmd.com>

# RF5187

## Absolute Maximum Ratings

Parameter	Rating	Unit
Supply Voltage ( $V_{CC}$ )	-0.5 to +6.5	$V_{DC}$
Power Control Voltage ( $V_{PC}$ )	-0.5 to +5V	V
DC Supply Current	300	mA
Input RF Power	+20	dBm
Output Load VSWR	20:1	
Operating Ambient Temperature	-40 to +85	$^{\circ}C$
Storage Temperature	-40 to +100	$^{\circ}C$



**Caution!** ESD sensitive device.

RF Micro Devices believes the furnished information is correct and accurate at the time of this printing. RoHS marking based on EUDirective2002/95/EC (at time of this printing). However, RF Micro Devices reserves the right to make changes to its products without notice. RF Micro Devices does not assume responsibility for the use of the described product(s).

Parameter	Specification			Unit	Condition
	Min.	Typ.	Max.		
<b>Overall</b>					$T=25^{\circ}C$ , $V_{CC}=5.0V$ , $I_{CC}=240mA$ , Freq=2140MHz, $P_{OUT}=13dBm$
Frequency Range	800		2500	MHz	
Output Power		13		dBm	
OP1dB		29		dBm	
Small Signal Gain	13		15	dB	
Input VSWR		1.5:1			With external matching network.
<b>Two-Tone Specification</b>					
Output IP3	41	43	45	dBm	13dBm per tone.
<b>Power Control</b>					
$V_{PC}$	2.7	3.1	3.7	V	To obtain 240mA idle current.
Power Control "OFF"	0.2	0.5		V	Threshold voltage at device input.
<b>Power Supply</b>					
Power Supply Voltage	5		6	V	
Supply Current			240	mA	
Power Down Current		2	10	$\mu A$	$V_{PC}=0.2V$

Note: For infrastructure class operation, the maximum allowable current over all operating conditions is 260mA. This implies the need for an external active bias control network to control  $I_{CC}$  over temperature and normal process variation. A recommended active bias control circuit is included in the datasheet.

The maximum continuous allowable dissipated power ( $I_{CC} * V_{CC} - P_{RF}$ ) for this part is 1.3W. For  $V_{CC}=5.0V$ , this implies an  $I_{CC}$  limit of 260mA. A  $V_{CC}$  of 6.0V would have an  $I_{CC}$  limit of 215mA.

A constant  $I_{CC}$  of 180mA to 220mA provides an excellent combination of high linearity and low power dissipation. Refer to W-CDMA ACP curves at bottom of datasheet.

Pin	Function	Description	Interface Schematic
1	RF IN	RF input. This input is DC-coupled, so an external blocking capacitor is required if this pin is connected to a DC path. An optimum match to $50\Omega$ is obtained by providing an external series capacitor of 2.4pF and then a shunt capacitor of 2.4pF. Those values are typical for 2140MHz; other values may be required for other frequencies.	
2	RF IN	Same as pin 1.	
3	PC	Power control pin. For obtaining maximum performance, the voltage on this pin can be used to set correct bias level. For low power linear applications, it is recommended that a constant bias control loop be used (see datasheet evaluation board schematic). A voltage of 0.5V or less at $V_{PC}$ brings the part into Power Down State.	
4	VCC	Power supply pin for the bias circuits. External low frequency bypass capacitors should be connected if no other low frequency decoupling is nearby.	
5	RF OUT	RF output and bias for the output stage. The power supply for the output transistor needs to be supplied to this pin. This can be done through a quarter-wavelength microstrip line that is RF-grounded at the other end, or through an RF inductor that supports the required DC currents. Optimum load impedance is achieved by providing a shunt capacitor of 1.8pF and a series capacitor of 3.3pF. Those values are typical for 2140MHz; other values may be required for other frequencies. Since there are several output pins available (which are internally connected), one pin can be used for connecting the bias, another for connecting a (third) harmonic trap filter, and the other pins for the RF output.	
6	RF OUT	Same as pin 5.	
7	RF OUT	Same as pin 5.	
8	RF OUT	Same as pin 5.	
Pkg Base	GND	Ground connection. The backside of the package should be connected to the ground plane through a short path (i.e., vias under the device may be required).	

## Evaluation Board Schematic 2140MHz Operation

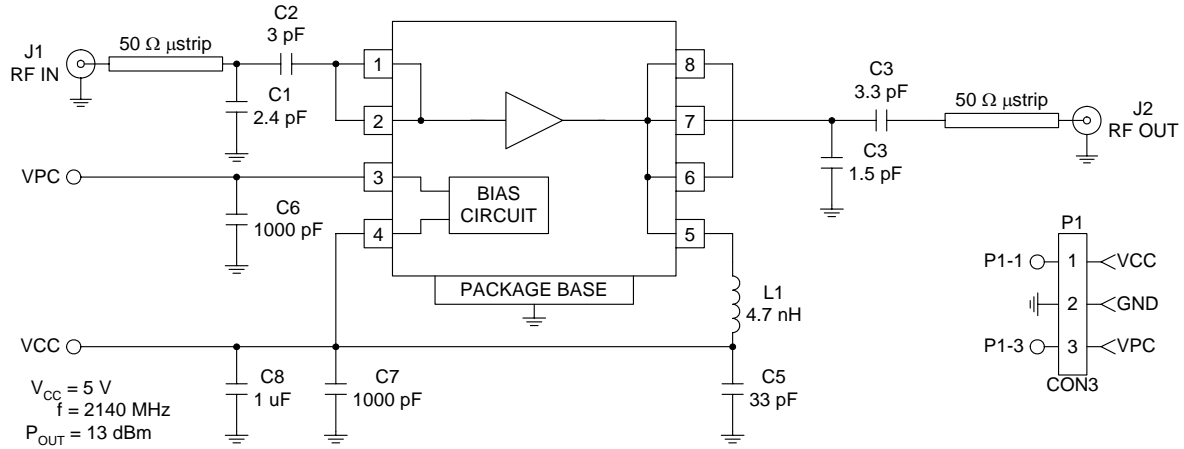

## Constant Bias Circuit

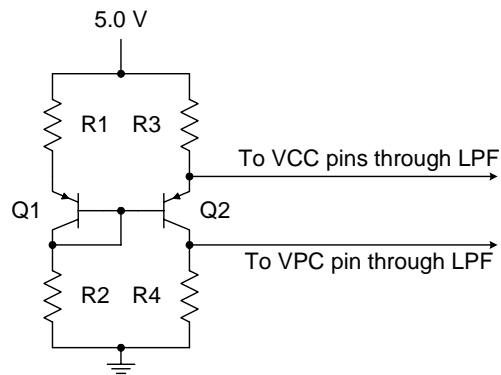

Bias Point	R1	R2	R3	R4
mA	$\Omega$	$\Omega$	$\Omega$	$\Omega$
100	120	1200	3.6	820
120	120	1200	3.0	820
150	120	1200	2.5	820
180	120	1200	2.0	820
200	120	1200	1.8	820
220	120	1200	1.7	820
240	120	1200	1.6	820

## Evaluation Board Layout Board Size 1.5" x 1.0" Board Thickness 0.031", Board Material FR-4

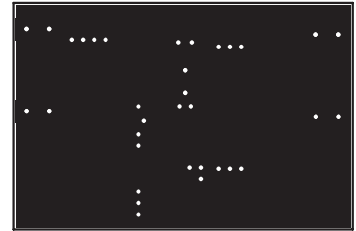
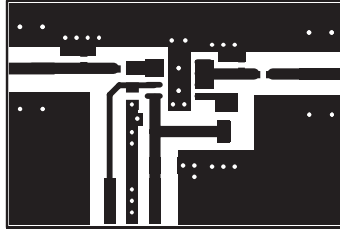
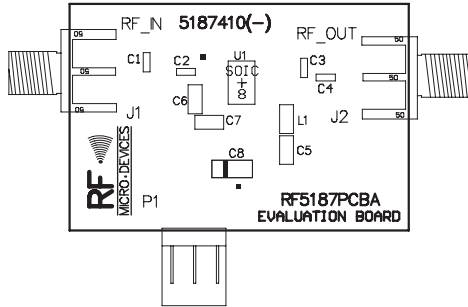

# RF5187

