

FEATURES

- **Tiny: Two 10-Bit DACs in an 8-Lead MSOP—Half the Board Space of an SO-8**
- **Micropower: 60µA per DAC**
Sleep Mode: 1µA for Extended Battery Life
- **Rail-to-Rail Voltage Outputs Drive 1000pF**
- **Wide 2.7V to 5.5V Supply Range**
- **Double Buffered for Independent or Simultaneous DAC Updates**
- **Reference Range Includes Supply for Ratiometric 0V-to- V_{CC} Output**
- **Reference Input Has Constant Impedance over All Codes (260kΩ Typ)—Eliminates External Buffers**
- **3-Wire Serial Interface with Schmitt Trigger Inputs**
- **Differential Nonlinearity: $\leq \pm 0.75\text{LSB}$ Max**

APPLICATIONS

- Mobile Communications
- Digitally Controlled Amplifiers and Attenuators
- Portable Battery-Powered Instruments
- Automatic Calibration for Manufacturing
- Remote Industrial Devices

 LTC and LT are registered trademarks of Linear Technology Corporation.

DESCRIPTION

The LTC[®]1661 integrates two accurate, serially addressable, 10-bit digital-to-analog converters (DACs) in a single tiny MS8 package. Each buffered DAC draws just 60µA total supply current, yet is capable of supplying DC output currents in excess of 5mA and reliably driving capacitive loads up to 1000pF. Sleep mode further reduces total supply current to a negligible 1µA.

Linear Technology's proprietary, inherently monotonic voltage interpolation architecture provides excellent linearity while allowing for an exceptionally small external form factor. The double-buffered input logic provides simultaneous update capability and can be used to write to either DAC without interrupting Sleep mode.

Ultralow supply current, power-saving Sleep mode and extremely compact size make the LTC1661 ideal for battery-powered applications, while its straightforward usability, high performance and wide supply range make it an excellent choice as a general purpose converter.

For additional outputs and even greater board density, please refer to the LTC1660 micropower octal DAC for 10-bit applications. For 8-bit applications, please consult the LTC1665 micropower octal DAC.

BLOCK DIAGRAM

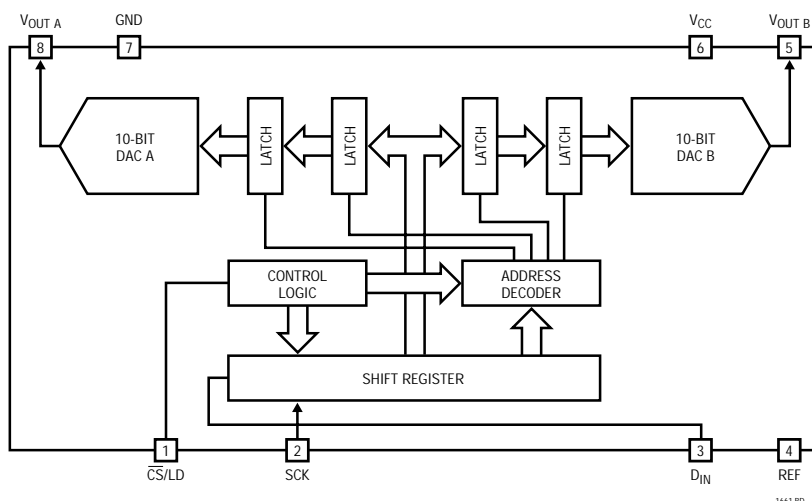

Differential Nonlinearity (DNL)

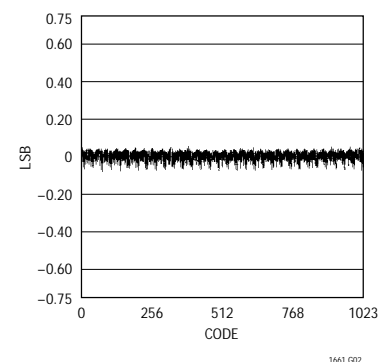

LTC1661

ABSOLUTE MAXIMUM RATINGS

(Note 1)

V_{CC} to GND	-0.3V to 7.5V	Operating Temperature Range	
Logic Inputs to GND	-0.3V to 7.5V	LTC1661C	0°C to 70°C
$V_{OUT A}$, $V_{OUT B}$, REF to GND	-0.3V to $V_{CC} + 0.3V$	LTC1661I	-40°C to 85°C
Maximum Junction Temperature	125°C	Lead Temperature (Soldering, 10 sec)	300°C
Storage Temperature Range	-65°C to 150°C		

PACKAGE/ORDER INFORMATION

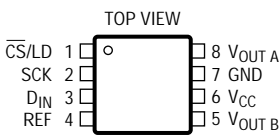
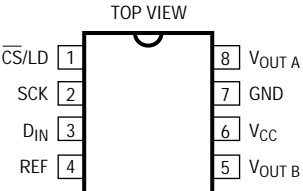
 <p>MS8 PACKAGE 8-LEAD PLASTIC MSOP $T_{JMAX} = 125^{\circ}C$, $\theta_{JA} = 150^{\circ}C/W$</p>	ORDER PART NUMBER	 <p>N8 PACKAGE 8-LEAD PLASTIC DIP $T_{JMAX} = 125^{\circ}C$, $\theta_{JA} = 100^{\circ}C/W$</p>	ORDER PART NUMBER
	LTC1661CMS8 LTC1661IMS8		LTC1661CN8 LTC1661IN8
	MS8 PART MARKING		
	LTDV LTDW		

Consult factory for Military grade parts.

ELECTRICAL CHARACTERISTICS

The ● denotes the specifications which apply over the full operating temperature range, otherwise specifications are at $T_A = 25^{\circ}C$. $V_{CC} = 2.7V$ to $5.5V$, $V_{REF} \leq V_{CC}$, V_{OUT} Unloaded unless otherwise noted.

SYMBOL	PARAMETER	CONDITIONS	MIN	TYP	MAX	UNITS
Accuracy						
	Resolution		●	10		Bits
	Monotonicity	$1V \leq V_{REF} \leq V_{CC} - 0.1V$ (Note 2)	●	10		Bits
DNL	Differential Nonlinearity	$1V \leq V_{REF} \leq V_{CC} - 0.1V$ (Note 2)	●	± 0.1	± 0.75	LSB
INL	Integral Nonlinearity	$1V \leq V_{REF} \leq V_{CC} - 0.1V$ (Note 2)	●	± 0.4	± 2	LSB
V_{OS}	Offset Error	Measured at Code 20	●	± 5	± 30	mV
	V_{OS} Temperature Coefficient			± 15		$\mu V/^{\circ}C$
FSE	Full-Scale Error	$V_{CC} = 5V$, $V_{REF} = 4.096V$	●	± 1	± 12	LSB
	Full-Scale Error Temperature Coefficient			± 30		$\mu V/^{\circ}C$
PSR	Power Supply Rejection	$V_{REF} = 2.5V$		0.18		LSB/V
Reference Input						
	Input Voltage Range		●	0	V_{CC}	V
	Resistance	Active Mode	●	140	260	k Ω
	Capacitance		●	15		pF
I_{REF}	Reference Current	Sleep Mode	●	0.001	1	μA
Power Supply						
V_{CC}	Positive Supply Voltage	For Specified Performance	●	2.7	5.5	V
I_{CC}	Supply Current	$V_{CC} = 5V$ (Note 3)	●	120	195	μA
		$V_{CC} = 3V$ (Note 3)	●	95	154	μA
		Sleep Mode (Note 3)	●	1	3	μA

ELECTRICAL CHARACTERISTICS

The ● denotes the specifications which apply over the full operating temperature range, otherwise specifications are at $T_A = 25^\circ\text{C}$. $V_{CC} = 2.7\text{V}$ to 5.5V , $V_{REF} \leq V_{CC}$, V_{OUT} Unloaded unless otherwise noted.

SYMBOL	PARAMETER	CONDITIONS		MIN	TYP	MAX	UNITS
DC Performance							
	Short-Circuit Current Low	$V_{OUT} = 0\text{V}$, $V_{CC} = V_{REF} = 5\text{V}$, Code = 1023	●	10	25	100	mA
	Short-Circuit Current High	$V_{OUT} = V_{CC} = V_{REF} = 5\text{V}$, Code = 0	●	7	19	120	mA
AC Performance							
	Voltage Output Slew Rate	Rising (Notes 4, 5) Falling (Notes 4, 5)			0.60 0.25		V/ μs V/ μs
	Voltage Output Settling Time	To $\pm 0.5\text{LSB}$ (Notes 4, 5)			30		μs
	Capacitive Load Driving				1000		pF
Digital I/O							
V_{IH}	Digital Input High Voltage	$V_{CC} = 2.7\text{V}$ to 5.5V $V_{CC} = 2.7\text{V}$ to 3.6V	● ●	2.4 2.0			V V
V_{IL}	Digital Input Low Voltage	$V_{CC} = 4.5\text{V}$ to 5.5V $V_{CC} = 2.7\text{V}$ to 5.5V	● ●			0.8 0.6	V V
I_{LK}	Digital Input Leakage	$V_{IN} = \text{GND}$ to V_{CC}	●			± 10	μA
C_{IN}	Digital Input Capacitance	(Note 6)	●			10	pF

TIMING CHARACTERISTICS

The ● denotes the specifications which apply over the full operating temperature range, otherwise specifications are at $T_A = 25^\circ\text{C}$.

SYMBOL	PARAMETER	CONDITIONS		MIN	TYP	MAX	UNITS
$V_{CC} = 4.5\text{V}$ to 5.5V							
t_1	D_{IN} Valid to SCK Setup		●	40	15		ns
t_2	D_{IN} Valid to SCK Hold		●	0	-10		ns
t_3	SCK High Time	(Note 6)	●	30	14		ns
t_4	SCK Low Time	(Note 6)	●	30	14		ns
t_5	$\overline{\text{CS}}/\text{LD}$ Pulse Width	(Note 6)	●	80	27		ns
t_6	LSB SCK High to $\overline{\text{CS}}/\text{LD}$ High	(Note 6)	●	30	2		ns
t_7	$\overline{\text{CS}}/\text{LD}$ Low to SCK High	(Note 6)	●	20	-21		ns
t_9	SCK Low to $\overline{\text{CS}}/\text{LD}$ Low	(Note 6)	●	0	-5		ns
t_{11}	$\overline{\text{CS}}/\text{LD}$ High to SCK Positive Edge	(Note 6)	●	20	0		ns
	SCK Frequency	Square Wave (Note 6)	●			16.7	MHz
$V_{CC} = 2.7\text{V}$ to 5.5V							
t_1	D_{IN} Valid to SCK Setup	(Note 6)	●	60	20		ns
t_2	D_{IN} Valid to SCK Hold	(Note 6)	●	0	-10		ns
t_3	SCK High Time	(Note 6)	●	50	15		ns
t_4	SCK Low Time	(Note 6)	●	50	15		ns
t_5	$\overline{\text{CS}}/\text{LD}$ Pulse Width	(Note 6)	●	100	30		ns
t_6	LSB SCK High to $\overline{\text{CS}}/\text{LD}$ High	(Note 6)	●	50	3		ns
t_7	$\overline{\text{CS}}/\text{LD}$ Low to SCK High	(Note 6)	●	30	-14		ns
t_9	SCK Low to $\overline{\text{CS}}/\text{LD}$ Low	(Note 6)	●	0	-5		ns
t_{11}	$\overline{\text{CS}}/\text{LD}$ High to SCK Positive Edge	(Note 6)	●	30	0		ns
	SCK Frequency	Square Wave (Note 6)	●			10	MHz

Note 1: Absolute maximum ratings are those values beyond which the life of a device may be impaired.

Note 2: Nonlinearity and monotonicity are defined from code 20 to code 1023 (full scale). See Applications Information.

TIMING CHARACTERISTICS

Note 3: Digital inputs at 0V or V_{CC} .

Note 4: Load is 10k Ω in parallel with 100pF.

Note 5: $V_{CC} = V_{REF} = 5V$. DAC switched between $0.1V_{FS}$ and $0.9V_{FS}$, i.e., codes $k = 102$ and $k = 922$.

Note 6: Guaranteed by design and not subject to test.

TYPICAL PERFORMANCE CHARACTERISTICS

Integral Nonlinearity (INL)

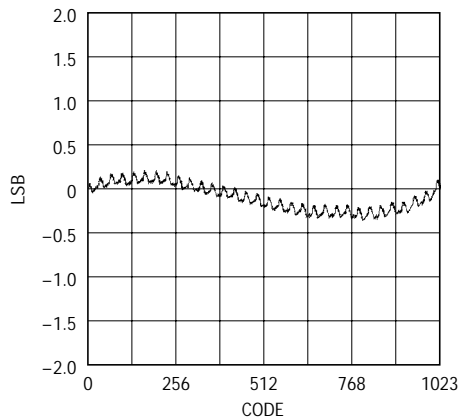

1661 G01

Differential Nonlinearity (DNL)

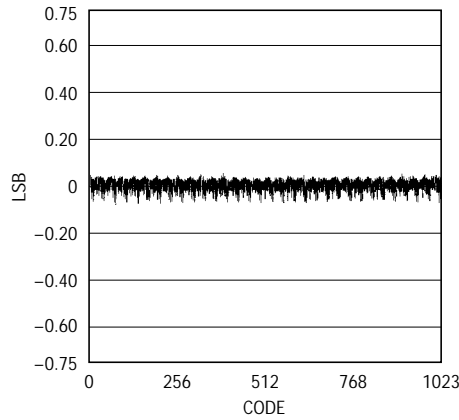

1661 G02

Minimum Supply Headroom vs Load Current (Output Sourcing)

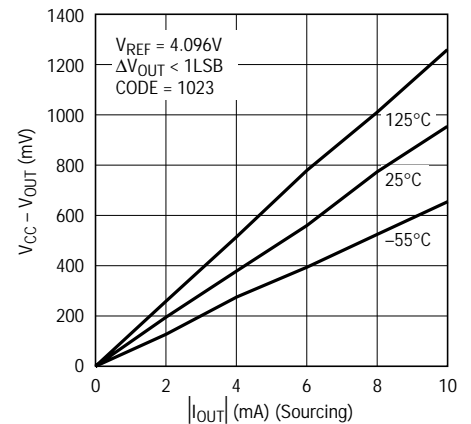

1661 G03

Minimum V_{OUT} vs Load Current (Output Sinking)

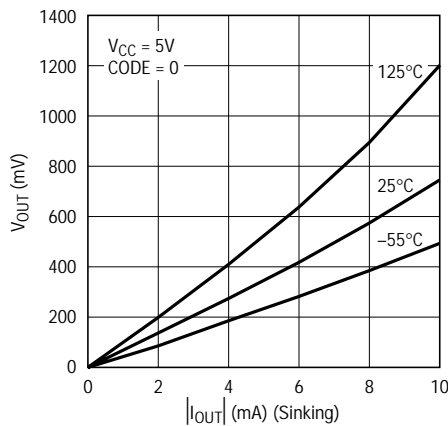

1661 G04

Midscale Output Voltage vs Load Current

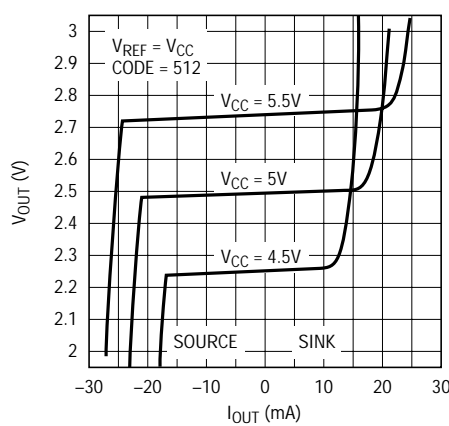

1661 G05

Midscale Output Voltage vs Load Current

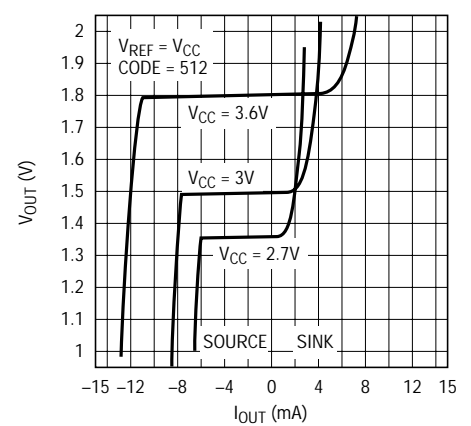

1661 G06

TYPICAL PERFORMANCE CHARACTERISTICS

Load Regulation vs Output Current

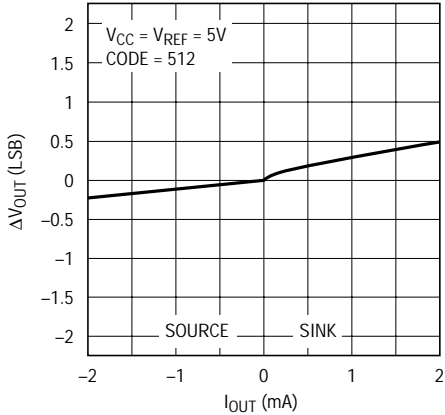

1661 G07

Load Regulation vs Output Current

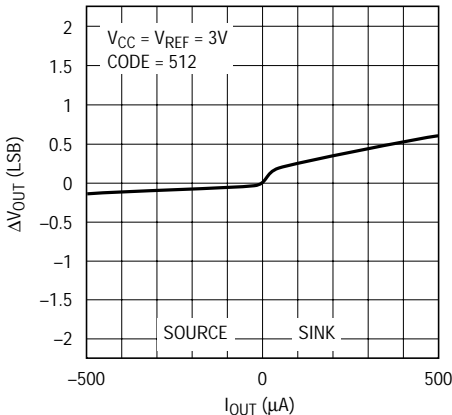

1661 G08

Large-Signal Step Response

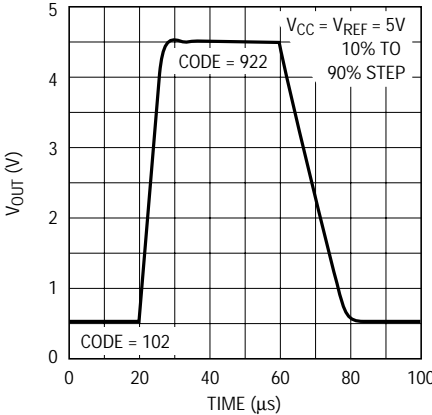

1661 G09

Supply Current vs Logic Input Voltage

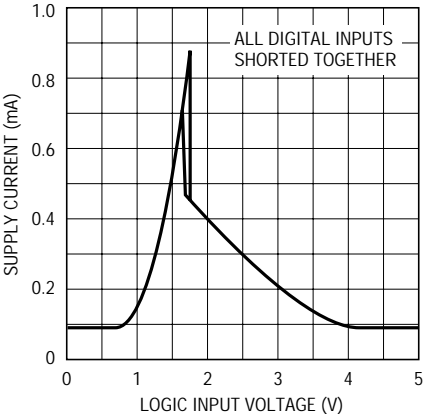

1661 G10

Supply Current vs Temperature

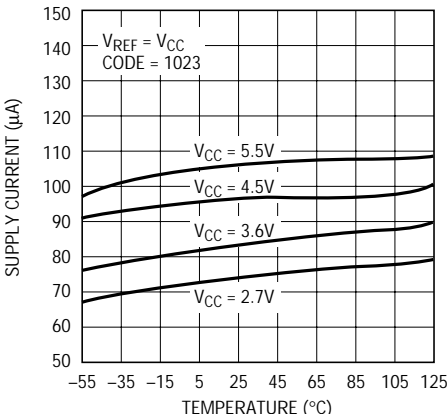

1661 G11

TIMING DIAGRAM

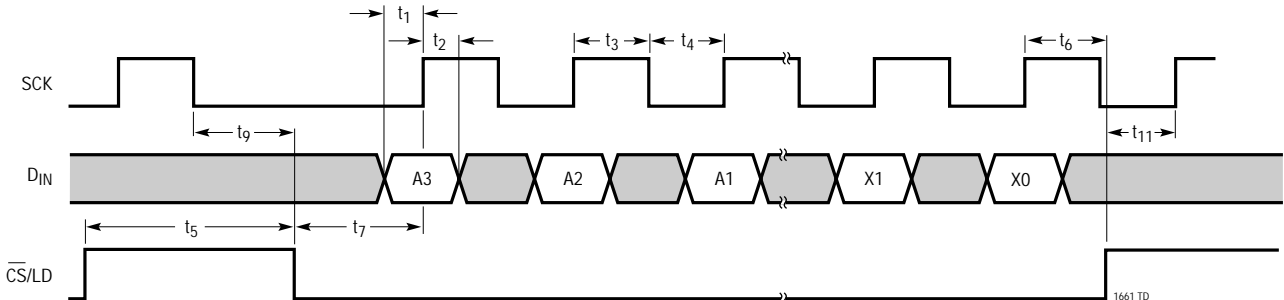

1661 TD

PIN FUNCTIONS

$\overline{\text{CS/LD}}$ (Pin 1): Serial Interface Chip Select/Load Input. When $\overline{\text{CS/LD}}$ is low, SCK is enabled for shifting data on D_{IN} into the register. When $\overline{\text{CS/LD}}$ is pulled high, SCK is disabled and the operation(s) specified in the Control code, A3-A0, is (are) performed. CMOS and TTL compatible.

SCK (Pin 2): Serial Interface Clock Input. CMOS and TTL compatible.

D_{IN} (Pin 3): Serial Interface Data Input. Input word data on the D_{IN} pin is shifted into the 16-bit register on the rising edge of SCK. CMOS and TTL compatible.

REF (Pin 4): Reference Voltage Input. $0V \leq V_{\text{REF}} \leq V_{\text{CC}}$.

$V_{\text{OUT A}}, V_{\text{OUT B}}$ (Pins 8,5): DAC Analog Voltage Outputs. The output range is

$$0 \leq V_{\text{OUTA}}, V_{\text{OUTB}} \leq V_{\text{REF}} \left(\frac{1023}{1024} \right)$$

V_{CC} (Pin 6): Supply Voltage Input. $2.7V \leq V_{\text{CC}} \leq 5.5V$.

GND (Pin 7): System Ground.

DEFINITIONS

Differential Nonlinearity (DNL): The difference between the measured change and the ideal 1LSB change for any two adjacent codes. The DNL error between any two codes is calculated as follows:

$$\text{DNL} = (\Delta V_{\text{OUT}} - \text{LSB}) / \text{LSB}$$

Where ΔV_{OUT} is the measured voltage difference between two adjacent codes.

Full-Scale Error (FSE): The deviation of the actual full-scale voltage from ideal. FSE includes the effects of offset and gain errors (see Applications Information).

Integral Nonlinearity (INL): The deviation from a straight line passing through the endpoints of the DAC transfer curve (Endpoint INL). Because the output cannot go below zero, the linearity is measured between full scale and the lowest code which guarantees the output will be greater than zero. The INL error at a given input code is calculated as follows:

$$\text{INL} = [V_{\text{OUT}} - V_{\text{OS}} - (V_{\text{FS}} - V_{\text{OS}})(\text{code}/1023)] / \text{LSB}$$

Where V_{OUT} is the output voltage of the DAC measured at the given input code.

Least Significant Bit (LSB): The ideal voltage difference between two successive codes.

$$\text{LSB} = V_{\text{REF}} / 1024$$

Resolution (n): Defines the number of DAC output states (2^n) that divide the full-scale range. Resolution does not imply linearity.

Voltage Offset Error (V_{OS}): Nominally, the voltage at the output when the DAC is loaded with all zeros. A single supply DAC can have a true negative offset, but the output cannot go below zero (see Applications Information).

For this reason, single supply DAC offset is measured at the lowest code that guarantees the output will be greater than zero.

OPERATION

Transfer Function

The transfer function for the LTC1661 is:

$$V_{\text{OUT(IDEAL)}} = \left(\frac{k}{1024} \right) V_{\text{REF}}$$

where k is the decimal equivalent of the binary DAC input code D9-D0 and V_{REF} is the voltage at REF (Pin 6).

Power-On Reset

The LTC1661 positively clears the outputs to zero scale when power is first applied, making system initialization consistent and repeatable.

Power Supply Sequencing

The voltage at REF (Pin 4) must not ever exceed the voltage at V_{CC} (Pin 6) by more than 0.3V. Particular care should be taken in the power supply turn-on and turn-off sequences to assure that this limit is observed. See Absolute Maximum Ratings.

Serial Interface

See Table 1. The 16-bit Input word consists of the 4-bit Control code, the 10-bit Input code and two don't-care bits.

Table 1. LTC1661 Input Word

Input Word															
A3	A2	A1	A0	D9	D8	D7	D6	D5	D4	D3	D2	D1	D0	X1	X0
Control Code				Input Code										Don't Care	

After the Input word is loaded into the register (see Figure 1), it is internally converted from serial to parallel format. The parallel 10-bit-wide Input code data path is then buffered by two latch registers.

The first of these, the Input Register, is used for loading new input codes. The second buffer, the DAC Register, is used for updating the DAC outputs. Each DAC has its own 10-bit Input Register and 10-bit DAC Register.

By selecting the appropriate 4-bit Control code (see Table 2) it is possible to perform single operations, such as loading one DAC or changing Power-Down status (Sleep/Wake). In addition, some Control codes perform two or more operations at the same time. For example, one such code loads DAC A, updates both outputs and Wakes the part up. The DACs can be loaded separately or together, but the outputs are always updated together.

Register Loading Sequence

See Figure 1. With $\overline{\text{CS/LD}}$ held low, data on the D_{IN} input is shifted into the 16-bit Shift Register on the positive edge of SCK. The 4-bit Control code, A3-A0, is loaded first, then the 10-bit Input code, D9-D0, ordered MSB-to-LSB in each case. Two don't-care bits, X1 and X0, are loaded last. When the full 16-bit Input word has been shifted in, $\overline{\text{CS/LD}}$ is pulled high, causing the system to respond according to Table 2. The clock is disabled internally when $\overline{\text{CS/LD}}$ is high. Note: SCK must be low when $\overline{\text{CS/LD}}$ is pulled low.

Sleep Mode

DAC control code 1110_b is reserved for the special Sleep instruction (see Table 2). In this mode, the digital parts of the circuit stay active while the analog sections are disabled; static power consumption is greatly reduced. The reference input and analog outputs are set in a high impedance state and all DAC settings are retained in memory so that when Sleep mode is exited, the outputs of DACs not updated by the Wake command are restored to their last active state.

Sleep mode is initiated by performing a load sequence using control code 1110_b (the DAC input code D9-D0 is ignored).

To save instruction cycles, the DACs may be prepared with new input codes during Sleep (control codes 0001_b and 0010_b); then, a single command (1000_b) can be used both to wake the part and to update the output values.

OPERATION

Table 2. DAC Control Functions

CONTROL				INPUT REGISTER STATUS	DAC REGISTER STATUS	POWER-DOWN STATUS (SLEEP/WAKE)	COMMENTS
A3	A2	A1	A0				
0	0	0	0	No Change	No Update	No Change	No Operation. Power-Down Status Unchanged (Part Stays In Wake or Sleep Mode)
0	0	0	1	Load DAC A	No Update	No Change	Load Input Register A with Data. DAC Outputs Unchanged. Power-Down Status Unchanged
0	0	1	0	Load DAC B	No Update	No Change	Load Input Register B with Data. DAC Outputs Unchanged. Power-Down Status Unchanged
0	0	1	1	Reserved			
0	1	0	0	Reserved			
0	1	0	1	Reserved			
0	1	1	0	Reserved			
0	1	1	1	Reserved			
1	0	0	0	No Change	Update Outputs	Wake	Load Both DAC Regs with Existing Contents of Input Regs. Outputs Update. Part Wakes Up
1	0	0	1	Load DAC A	Update Outputs	Wake	Load Input Reg A. Load DAC Regs with New Contents of Input Reg A and Existing Contents of Reg B. Outputs Update. Part Wakes Up
1	0	1	0	Load DAC B	Update Outputs	Wake	Load Input Reg B. Load DAC Regs with Existing Contents of Input Reg A and New Contents of Reg B. Outputs Update. Part Wakes Up
1	0	1	1	Reserved			
1	1	0	0	Reserved			
1	1	0	1	No Change	No Update	Wake	Part Wakes Up. Input and DAC Regs Unchanged. DAC Outputs Reflect Existing Contents of DAC Regs
1	1	1	0	No Change	No Update	Sleep	Part Goes to Sleep. Input and DAC Regs Unchanged. DAC Outputs Set to High Impedance State
1	1	1	1	Load DACs A, B with Same 10-Bit Code	Update Outputs	Wake	Load Both Input Regs. Load Both DAC Regs with New Contents of Input Regs. Outputs Update. Part Wakes Up

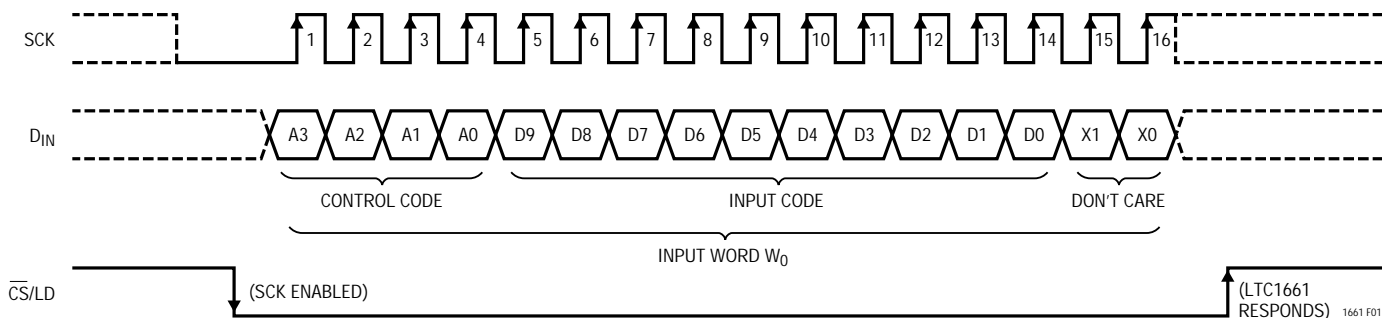

Figure 1. Register Loading Sequence

OPERATION

Voltage Outputs

Each of the rail-to-rail output amplifiers contained in the LTC1661 can typically source or sink up to 5mA ($V_{CC} = 5V$). The outputs swing to within a few millivolts of either supply when unloaded and have an equivalent output resistance of 85Ω (typical) when driving a load to the rails. The output amplifiers are stable driving capacitive loads up to 1000pF.

A small resistor placed in series with the output can be used to achieve stability for any load capacitance. A $1\mu F$ load can be successfully driven by inserting a 20Ω resistor in series with the V_{OUT} pin. A $2.2\mu F$ load needs only a 10Ω resistor, and a $10\mu F$ electrolytic capacitor can be used without any resistor (the equivalent series resistance of the capacitor itself provides the required small resistance). In any of these cases, larger values of resistance, capacitance or both may be substituted for the values given.

Rail-to-Rail Output Considerations

In any rail-to-rail DAC, the output swing is limited to voltages within the supply range.

If the DAC offset is negative, the output for the lowest codes limits at 0V as shown in Figure 2b.

Similarly, limiting can occur near full scale when the REF pin is tied to V_{CC} . If $V_{REF} = V_{CC}$ and the DAC full-scale error (FSE) is positive, the output for the highest codes limits at V_{CC} as shown in Figure 2c. No full-scale limiting can occur if V_{REF} is less than $V_{CC} - FSE$.

Offset and linearity are defined and tested over the region of the DAC transfer function where no output limiting can occur.

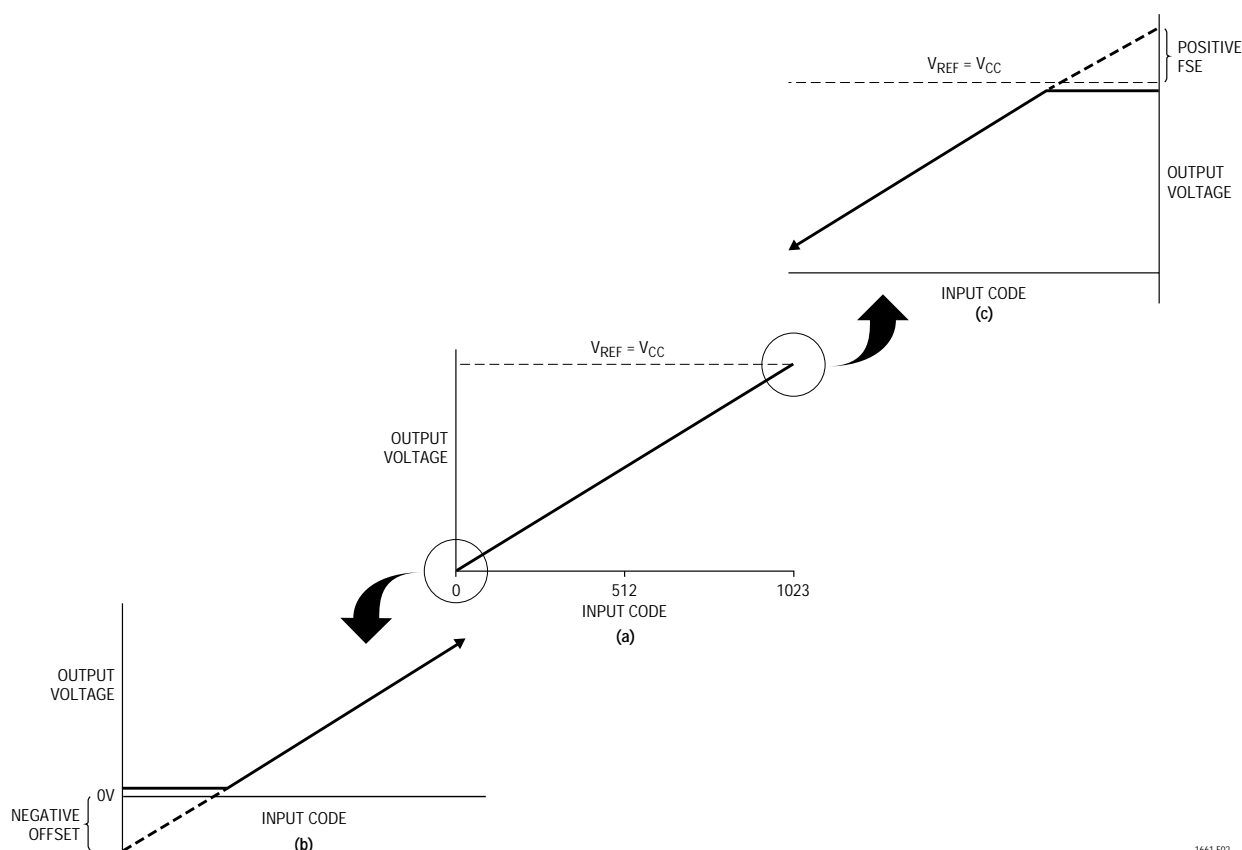
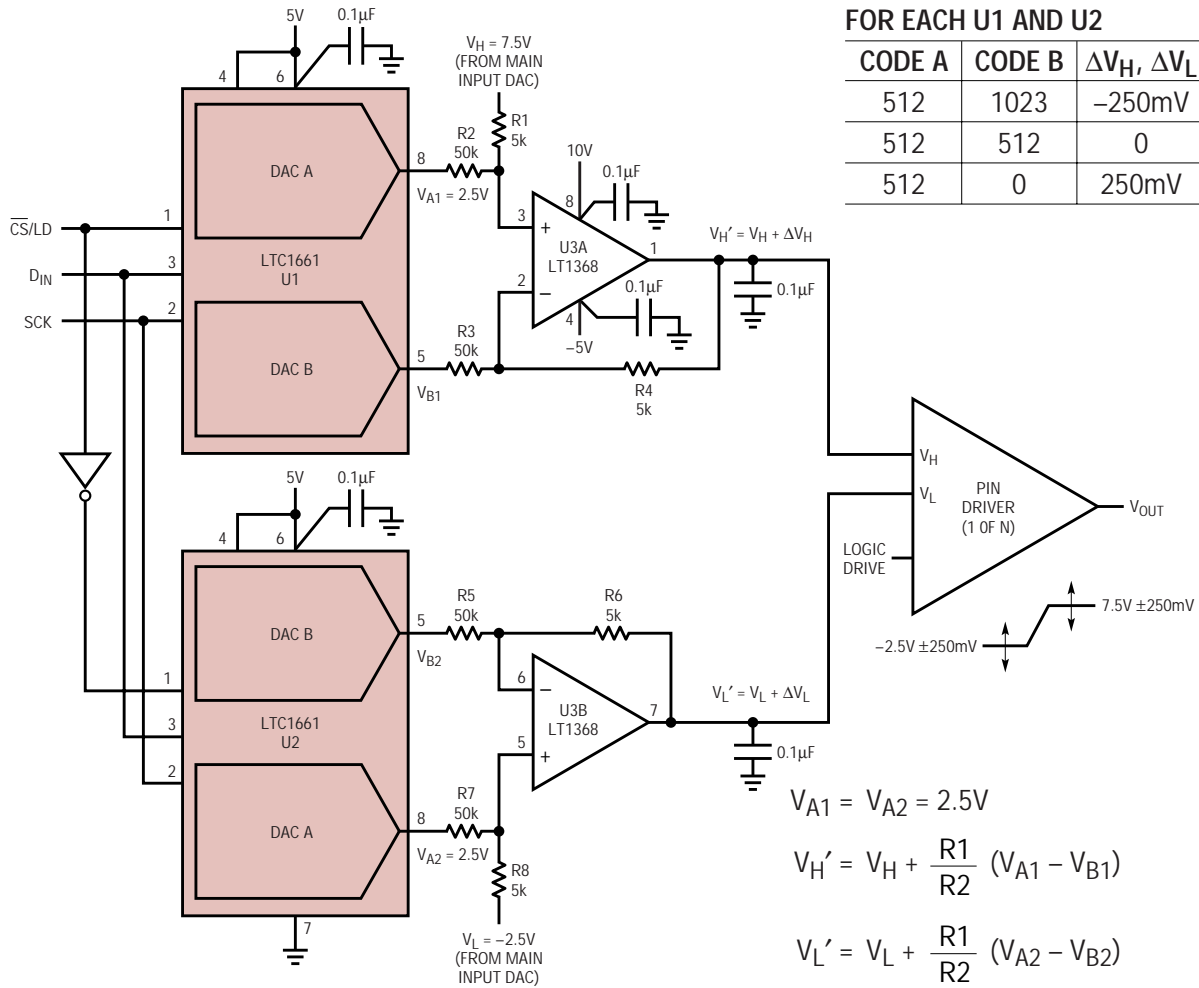

Figure 2. Effects of Rail-to-Rail Operation On a DAC Transfer Curve. (a) Overall Transfer Function (b) Effect of Negative Offset for Codes Near Zero Scale (c) Effect of Positive Full-Scale Error for Input Codes Near Full Scale When $V_{REF} = V_{CC}$

TYPICAL APPLICATIONS



FOR VALUES SHOWN,
 $\Delta V_H, \Delta V_L$ ADJUSTMENT RANGE = $\pm 250mV$
 $\Delta V_H, \Delta V_L$ STEP SIZE = $500\mu V$

1661 F03

Figure 3. Pin Driver V_H and V_L Adjustment in ATE Applications

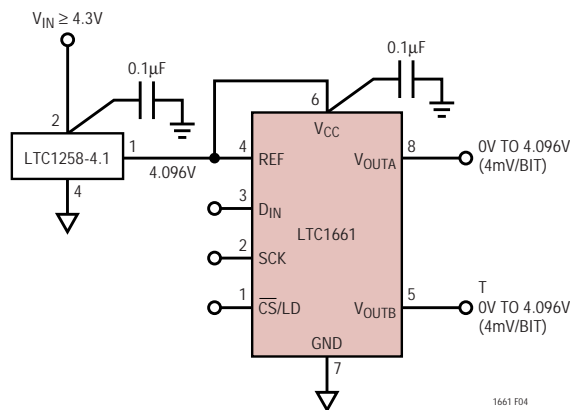

1661 F04

Figure 4. Using the LTC1258 and the LTC1661 In a Single Li-Ion Battery Application

PACKAGE DESCRIPTION Dimensions in inches (millimeters) unless otherwise noted.

MS8 Package
8-Lead Plastic MSOP
 (LTC DWG # 05-08-1660)

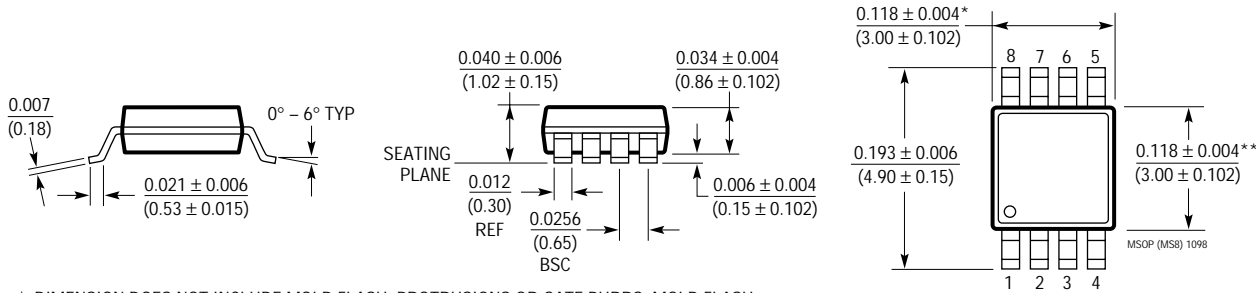

* DIMENSION DOES NOT INCLUDE MOLD FLASH, PROTRUSIONS OR GATE BURRS. MOLD FLASH, PROTRUSIONS OR GATE BURRS SHALL NOT EXCEED 0.006^* (0.152mm) PER SIDE
 ** DIMENSION DOES NOT INCLUDE INTERLEAD FLASH OR PROTRUSIONS. INTERLEAD FLASH OR PROTRUSIONS SHALL NOT EXCEED 0.006^* (0.152mm) PER SIDE

N8 Package
8-Lead PDIP (Narrow 0.300)
 (LTC DWG # 05-08-1510)

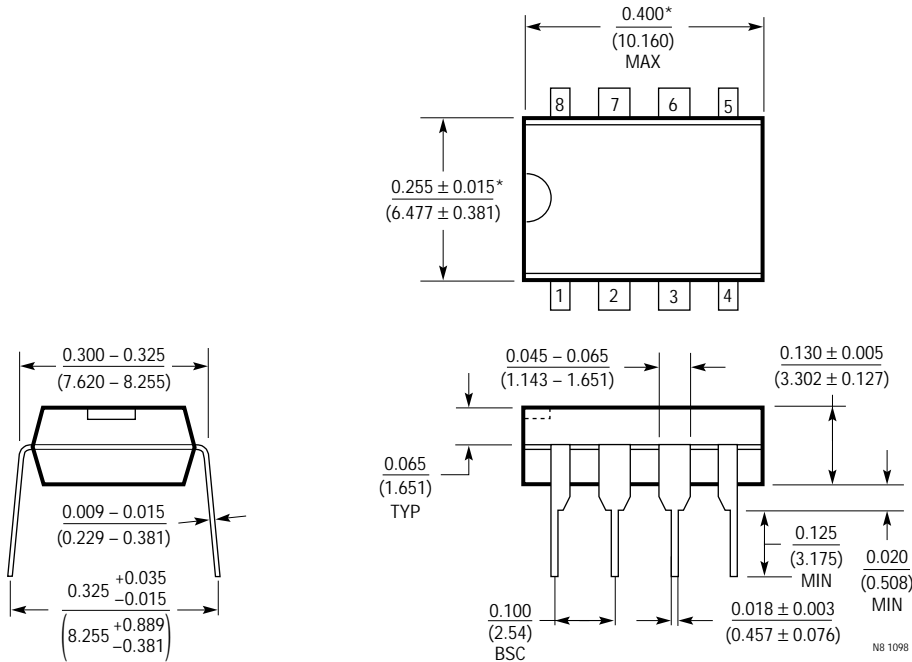

*THESE DIMENSIONS DO NOT INCLUDE MOLD FLASH OR PROTRUSIONS. MOLD FLASH OR PROTRUSIONS SHALL NOT EXCEED 0.010 INCH (0.254mm)

TYPICAL APPLICATION

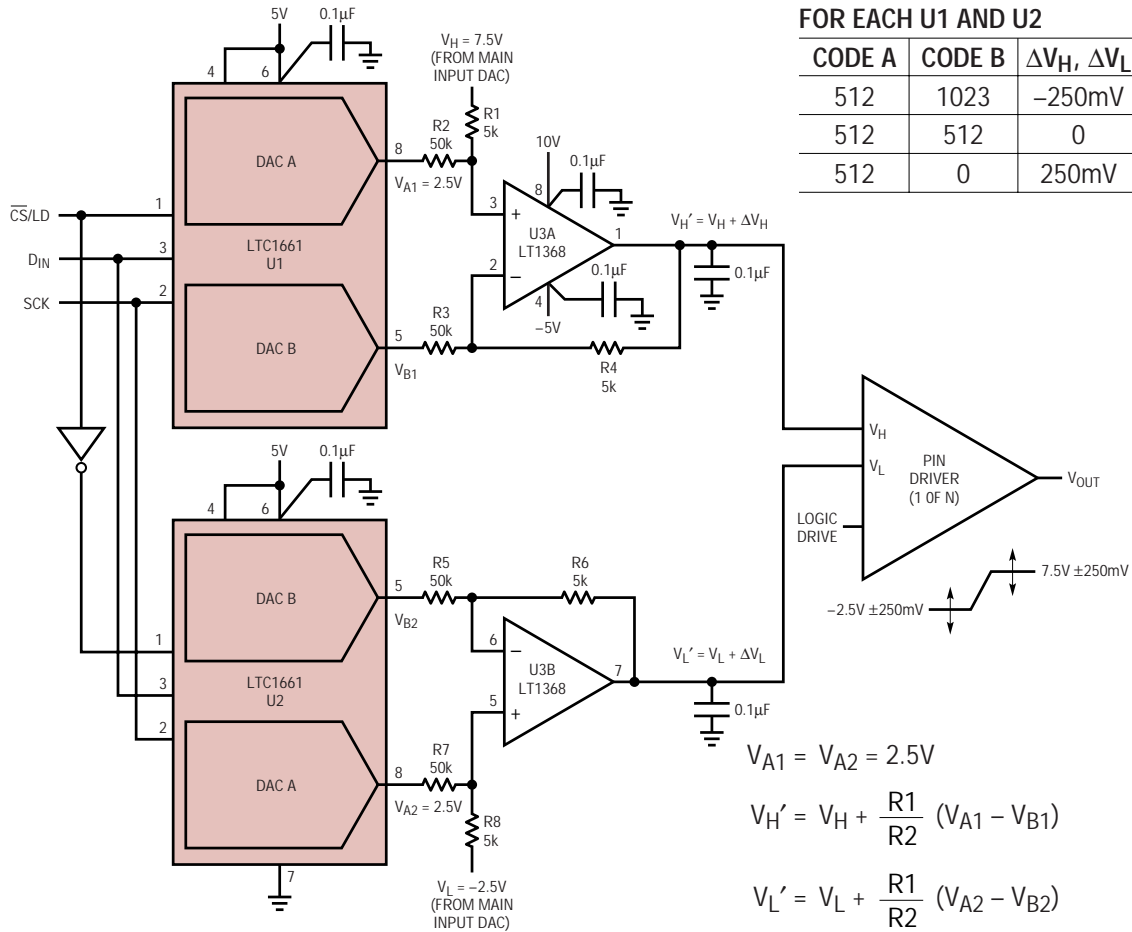

$$V_{A1} = V_{A2} = 2.5V$$

$$V_{H'} = V_H + \frac{R1}{R2} (V_{A1} - V_{B1})$$

$$V_{L'} = V_L + \frac{R1}{R2} (V_{A2} - V_{B2})$$

FOR VALUES SHOWN,
 $\Delta V_H, \Delta V_L$ ADJUSTMENT RANGE = $\pm 250mV$
 $\Delta V_H, \Delta V_L$ STEP SIZE = $500\mu V$

Pin Driver V_H and V_L Adjustment in ATE Applications

RELATED PARTS

PART NUMBER	DESCRIPTION	COMMENTS
LTC1446/LTC1446L	Dual 12-Bit V_{OUT} DACs in SO-8 Package with Internal Reference	LTC1446: $V_{CC} = 4.5V$ to $5.5V, V_{OUT} = 0V$ to $4.095V$ LTC1446L: $V_{CC} = 2.7V$ to $5.5V, V_{OUT} = 0V$ to $2.5V$
LTC1448	Dual 12-Bit V_{OUT} DAC in SO-8 Package	$V_{CC} = 2.7V$ to $5.5V$, External Reference Can Be Tied to V_{CC}
LTC1454/LTC1454L	Dual 12-Bit V_{OUT} DACs in SO-16 Package with Added Functionality	LTC1454: $V_{CC} = 4.5V$ to $5.5V, V_{OUT} = 0V$ to $4.095V$ LTC1454L: $V_{CC} = 2.7V$ to $5.5V, V_{OUT} = 0V$ to $2.5V$
LTC1458/LTC1458L	Quad 12-Bit Rail-to-Rail Output DACs with Added Functionality	LTC1458: $V_{CC} = 4.5V$ to $5.5V, V_{OUT} = 0V$ to $4.095V$ LTC1458L: $V_{CC} = 2.7V$ to $5.5V, V_{OUT} = 0V$ to $2.5V$
LTC1659	Single Rail-to-Rail 12-Bit V_{OUT} DAC in 8-Lead MSOP Package $V_{CC}: 2.7V$ to $5.5V$	Low Power Multiplying V_{OUT} DAC. Output Swings from GND to REF. REF Input Can Be Tied to V_{CC}
LTC1663	Single 10-Bit V_{OUT} DAC in SOT-23 Package	$V_{CC} = 2.7V$ to $5.5V$, Internal Reference, $60\mu A$
LTC1665/LTC1660	Octal 8/10-Bit V_{OUT} DAC in 16-Pin Narrow SSOP	$V_{CC} = 2.7V$ to $5.5V$, Micropower, Rail-to-Rail Output