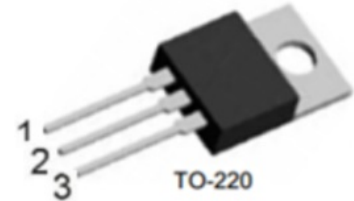
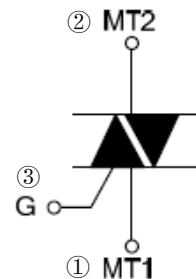

Description

Triacs is fabricated using separation diffusion processes ,the junction termination areas are passivated with glass. Thanks to highly sensitive triggering levels and reliability,the Triacs series is suitable for domestic lighting ,heating and motor speed controllers.

Applications

Domestic lighting ,heating and motor speed controllers.

Symbol

Ordering Information

Part No.	Package	Packing
BT136-600	TO-220	50pcs / Tube

ABSOLUTE MAXIMUM RATING

PARAMETER	SYMBOL	RATINGS	UNIT
Repetitive Peak Off State Voltage	BT136-600 VDRM	600	V
RMS On-state Current (Full sine wave; $T_{mb} \leq 107^\circ\text{C}$)	IT(RMS)	4	A
Non-Repetitive Peak. On-State Current (Full sine wave; $T_j = 25^\circ\text{C}$ prior to surge)	ITSM	25	A
$t = 2.0 \text{ ms}$ $t = 16.7 \text{ ms}$		27	
I^2t For Fusing $t = 10 \text{ ms}$	I^2t	3.1	A^2s
Rate of Rise of On-state Current $I_{TM} = 6 \text{ A}; I_G = 0.2 \text{ A}; dI_G/dt = 0.2 \text{ A}/\mu\text{s}$	diT /dt	50	A/ μs
T2+G+		50	
T2+G-		50	
T2-G-		10	
Peak Gate Current	IGM	2	A
Peak Gate Power	PGM	5	W
Average Gate Power (Over any 20ms period)	PG(AV)	0.5	W
Operating Junction Temperature	Tj	125	$^\circ\text{C}$
Storage Temperature	Tstg	-40~150	$^\circ\text{C}$

THERMAL CHARACTERISTICS

PARAMETER	SYMBOL	MIN	TYP	MAX	UNIT
Thermal Resistance Junction to Mounting Base Full cycle Half cycle	Rth j-mb			3 3.7	K/W
Thermal Resistance Junction to Ambient In free air	Rth j-a		60		K/W

ELECTRICAL CHARACTERISTICS (T_J = 25°C, unless otherwise stated)

PARAMETER	SYMBOL	TEST CONDITIONS	MIN	TYP	MAX	UNIT
STATIC CHARACTERISTICS						
Gate Trigger Current	I _{GT}	V _D =12V, I _T =0.1A T2+G+ T2+G- T2-G- T2-G+		5 8 11 30	35 35 35 70	mA
Latching Current	I _L	V _D =12V, I _T =0.1A T2+G+ T2+G- T2-G- T2-G+		7 16 5 7	20 30 20 30	mA
Holding Current	I _H	V _D =12V, I _T =0.1A		5	15	mA
Gate Trigger Voltage	V _{GT}	V _D =12V, I _T =0.1A; T _J =25°C V _D =400V, I _T =0.1A; T _J =125°C		0.7 0.25	1.0	V V
On-State Voltage	V _T	I _T =5A		1.4	1.7	V
Off-state Leakage Current	I _D	V _D =600V, T _J =125°C		0.1	0.5	mA
DYNAMIC CHARACTERISTICS						
Critical Rate of Rise of off-state Voltage	dV _D /dt	V _{DM} =67% V _{DRM(max)} , T _J =125°C Exponential waveform, Gate open circuit	100	250		V/μs
Critical Rate of Change of commutating Voltage	dV _{com} /dt	V _{DM} =400V, T _J =95°C, I _T =4A dI _{com} /dt = 1.8A/ms, Gate open circuit		50		V/μs
Gate Controlled Turn-on Time	t _{gt}	I _{TM} =6A, V _D =V _{DRM} , I _G =0.1mA dI _G /dt=5A/μs		2		μs

TYPICAL CHARACTERISTICS

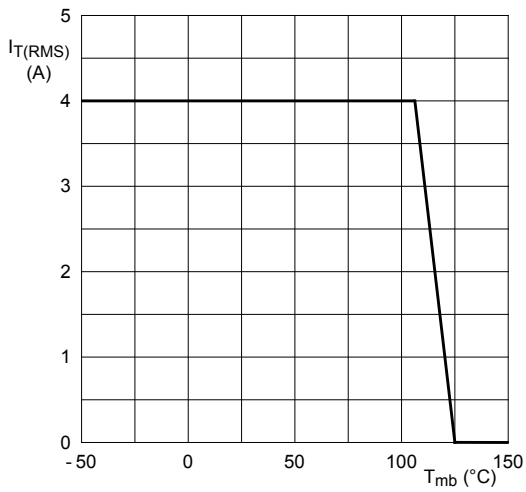
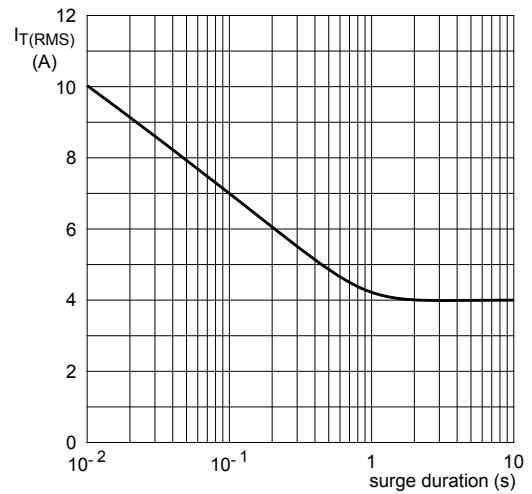
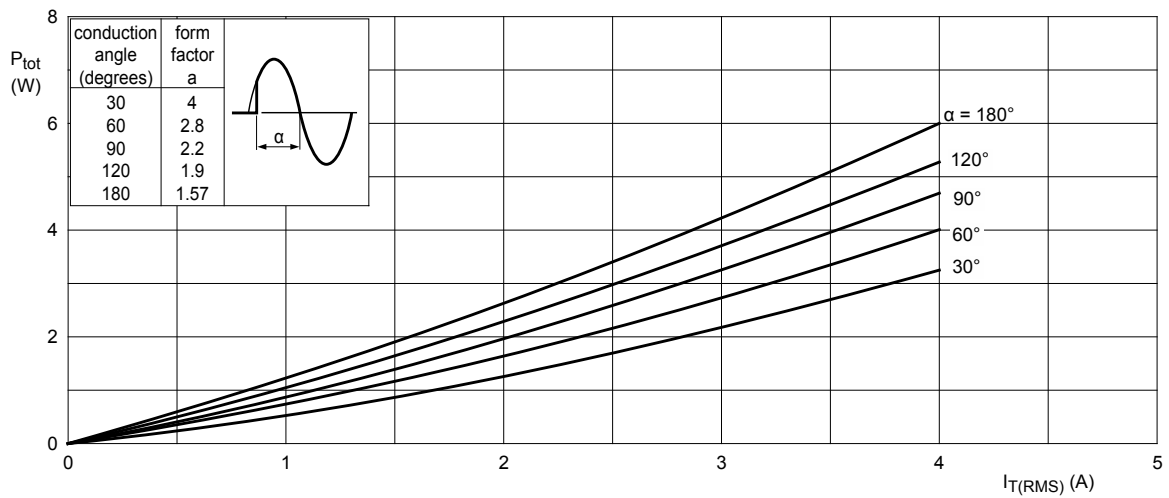

Fig. 1. RMS on-state current as a function of mounting base temperature; maximum values



f = 50 Hz
 $T_{mb} \leq 107^\circ\text{C}$

Fig. 2. RMS on-state current as a function of surge duration; maximum values



α = conduction angle
 a = form factor = $I_{T(RMS)} / I_{T(AV)}$

Fig. 3. Total power dissipation as a function of RMS on-state current; maximum values

TYPICAL CHARACTERISTICS

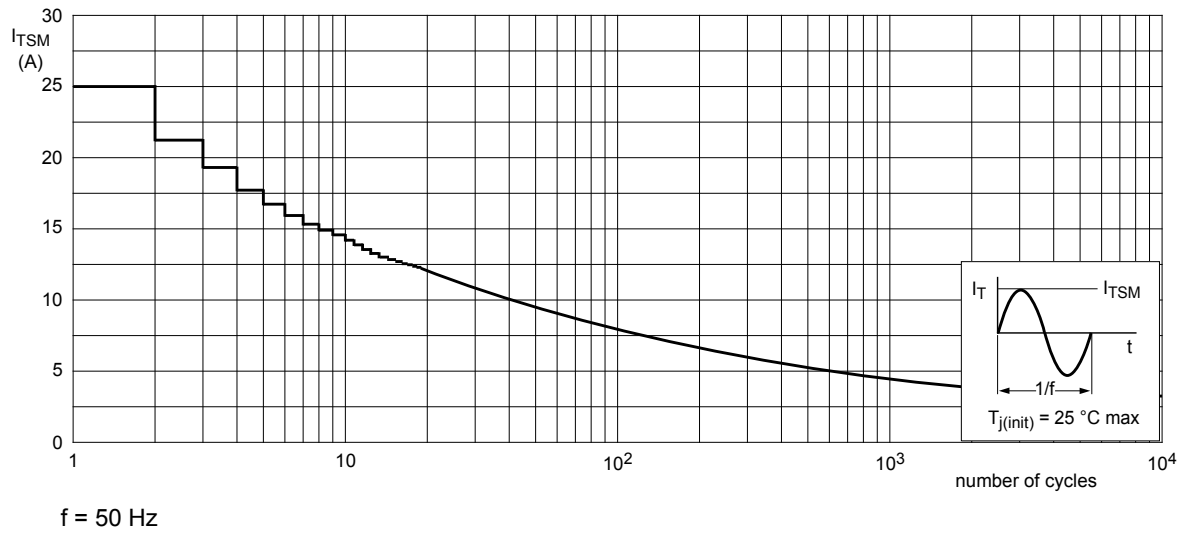

Fig. 4. Non-repetitive peak on-state current as a function of the number of sinusoidal current cycles; maximum values

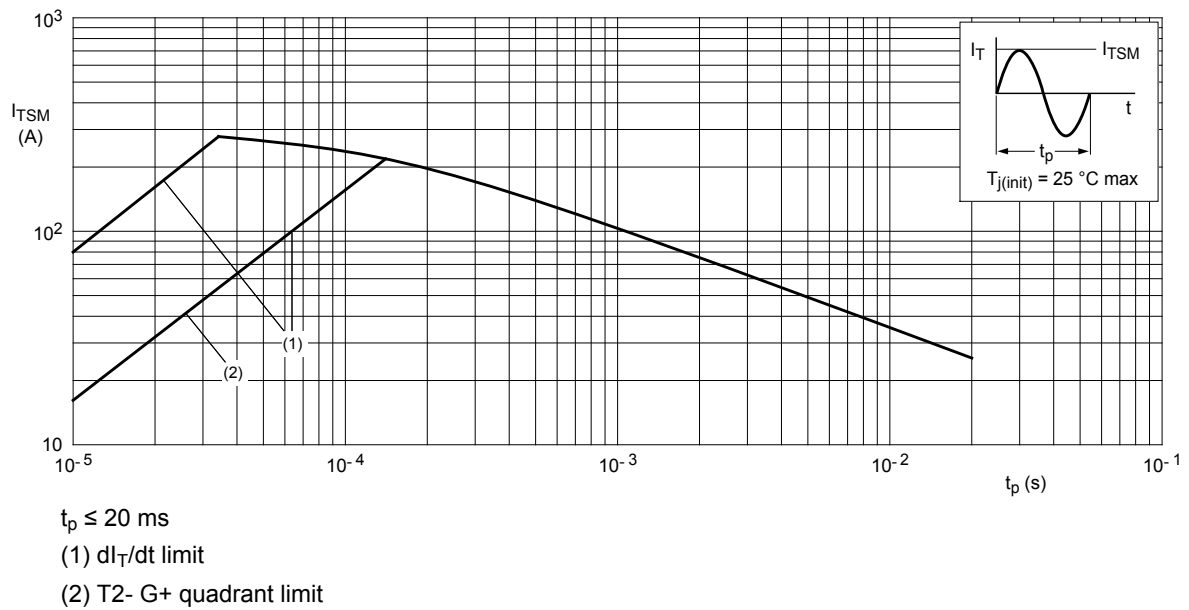

Fig. 5. Non-repetitive peak on-state current as a function of pulse width; maximum values

TYPICAL CHARACTERISTICS

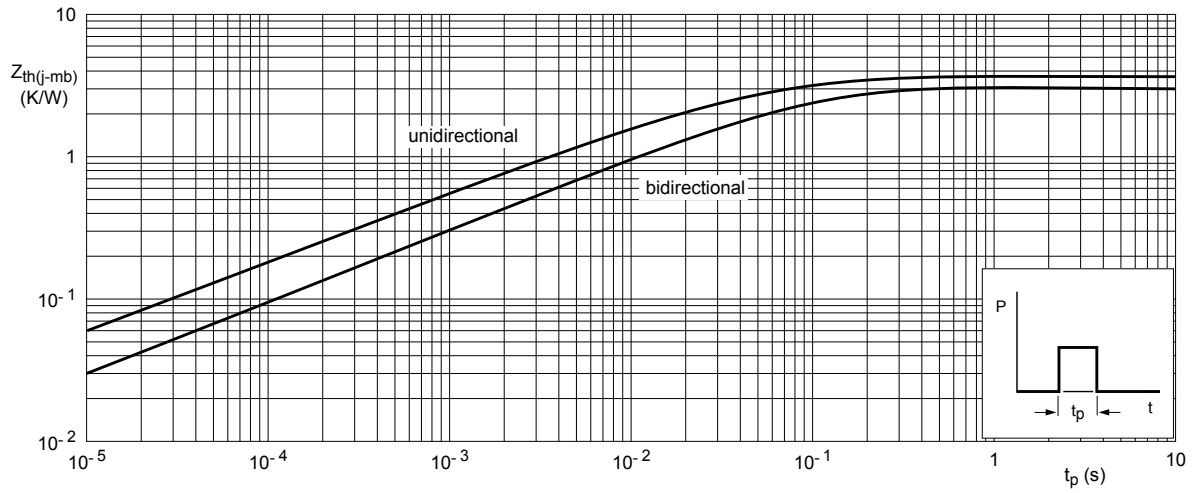
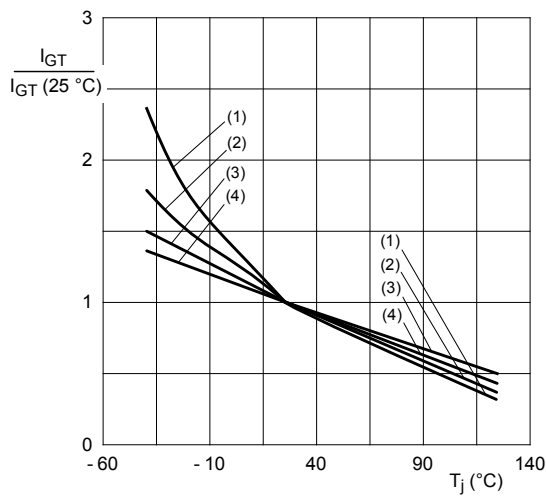

Fig. 6. Transient thermal impedance from junction to mounting base as a function of pulse width



- (1) T2- G+
- (2) T2- G-
- (3) T2+ G-
- (4) T2+ G+

Fig. 7. Normalized gate trigger current as a function of junction temperature

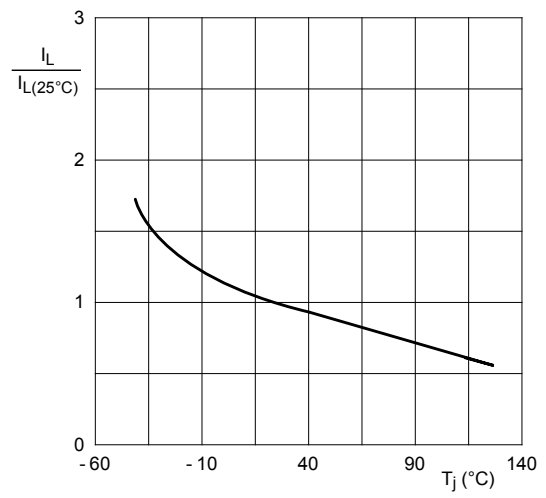

Fig. 8. Normalized latching current as a function of junction temperature

TYPICAL CHARACTERISTICS

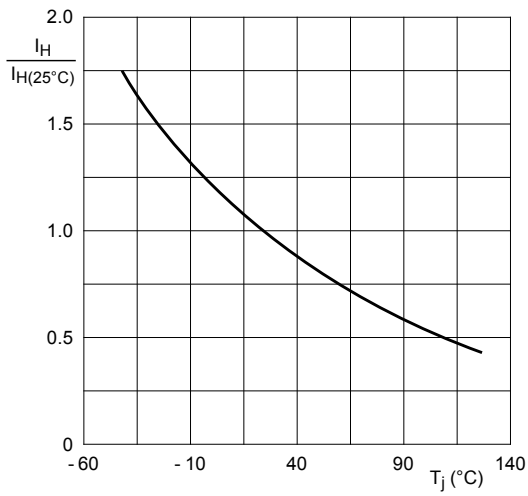
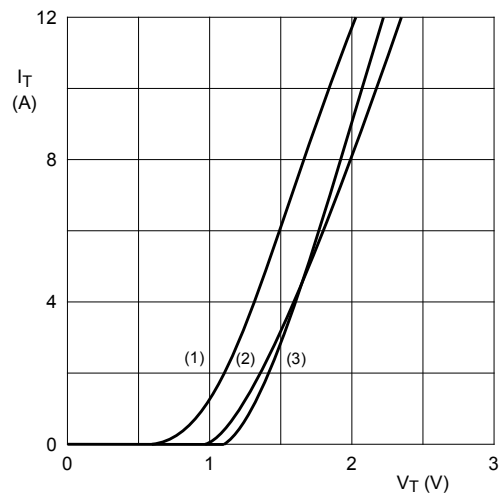

Fig. 9. Normalized holding current as a function of junction temperature



$V_o = 1.27 \text{ V}$

$R_s = 0.091 \Omega$

(1) $T_j = 125^\circ\text{C}$; typical values (2)

$T_j = 125^\circ\text{C}$; maximum values (3)

$T_j = 25^\circ\text{C}$; maximum values

Fig. 10. On-state current as a function of on-state voltage

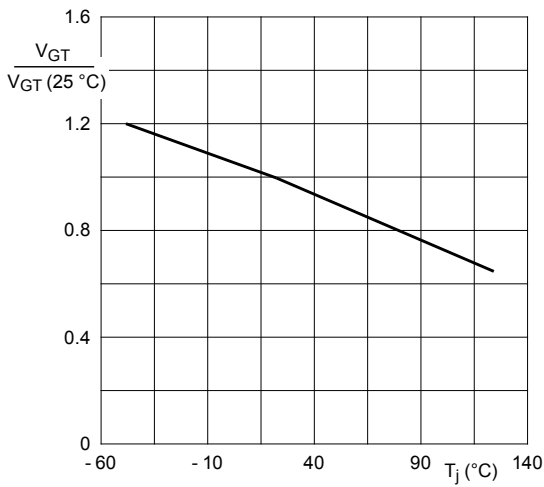
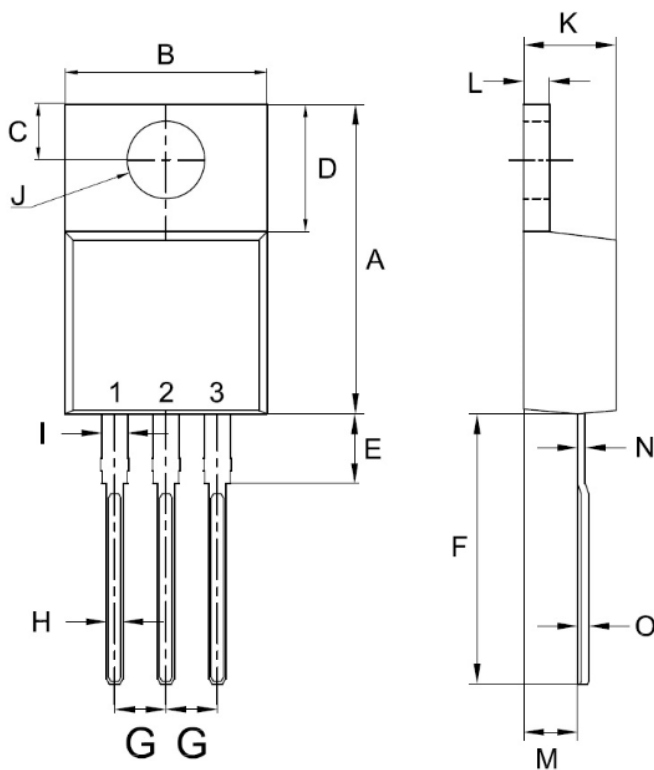

Fig. 11. Normalized gate trigger voltage as a function of junction temperature

TO-220 Mechanical Drawing



TO-220AB Unit:mm		
DIM	MIN	MAX
A	14.80	15.80
B	9.57	10.57
C	2.54	2.94
D	5.80	6.80
E	2.95	3.95
F	12.70	13.40
G	2.34	2.74
H	0.51	1.11
I	0.97	1.57
J	3.54 ϕ	4.14 ϕ
K	4.27	4.87
L	1.07	1.47
M	2.65	3.05
N	0.30	0.46
O	0.48	0.64