

Low Power PCIe 3.0 Clock Generator with 4 HCSL Outputs

Features

- PCIe® 3.0, 2.0 and 1.0 compliant
- LVDS compatible outputs
- Supply voltage of 3.3V ±5%
- 25MHz crystal or clock input frequency
- Low power consumption with independent output power supply 1.05V to 3.3V
- Jitter 40ps cycle-to-cycle (typ)
- Spread of -0.5%, -1.0%, -1.5%, and no spread
- Industrial temperature range
- Spread Bypass option available
- Spread and frequency selection via external pins
- Packaging: (Pb-free and Green)
→20-pin, 173-mil wide TSSOP

Description

The PI6CFGL402B is a spread spectrum clock generator compliant to PCI Express® 3.0 and Ethernet requirements. The device is used for PC or embedded systems to substantially reduce Electromagnetic Interference (EMI).

The PI6CFGL402B provides four differential (HCSL) or LVDS spread spectrum outputs. The PI6CFGL402B is configured to select spread and clock selection. Using Pericom's patented Phase-Locked Loop (PLL) techniques, the device takes a 25MHz crystal input and produces four pairs of differential outputs (HCSL) at 100MHz and 200MHz clock frequencies. It also provides spread selection of -0.5%, -1.0%, -1.5%, and no spread.

Block Diagram

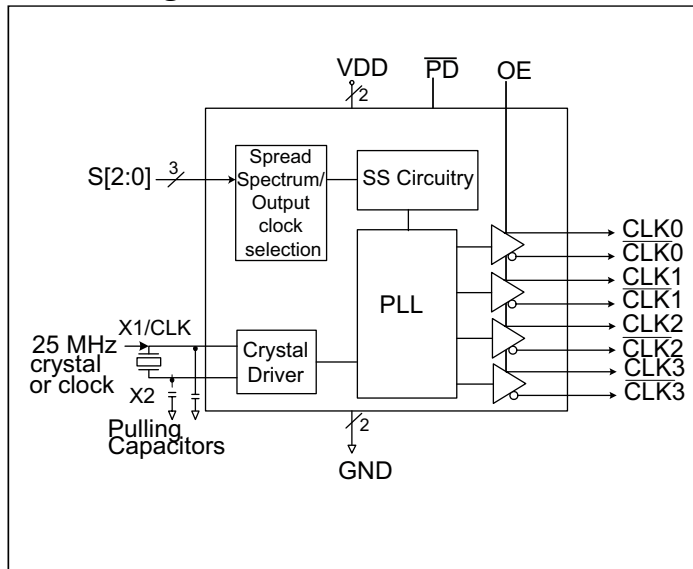

Pin Configuration

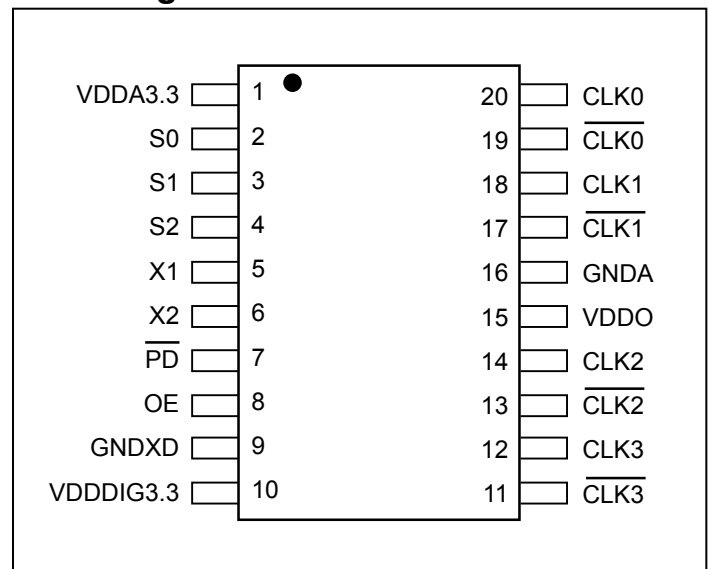

Pin Description

| Pin # | Pin Name | I/O Type | Description |
|-------|--------------------------|----------|---|
| 1 | VDDA3.3 | Power | 3.3V power for PLL core. |
| 2 | S0 | Input | Spread Spectrum Select pin #0. See Spread Selection Table. Internal pull-up resistor. |
| 3 | S1 | Input | Spread Spectrum Select pin #1. See Spread Selection Table. Internal pull-up resistor. |
| 4 | S2 | Input | Spread Spectrum Select pin #2. See Spread Selection Table. Internal pull-up resistor. |
| 5 | X1 | Input | Crystal connection. |
| 6 | X2 | Output | Crystal connection. |
| 7 | $\overline{\text{PD}}$ | Input | Power down. Internal pull-up resistor. |
| 8 | OE | Input | Output enable. Tri-states output (High=enable outputs); Low=disable outputs). Internal pull-up resistor. |
| 9 | GNDXD | Power | Connect to digital circuit ground. |
| 10 | VDDDIG3.3 | Power | 3.3V digital power. |
| 11 | $\overline{\text{CLK3}}$ | Output | Selectable 100/200 MHz Spread Spectrum differential compliment output clock 3. LOW when output is disabled. |
| 12 | CLK3 | Output | Selectable 100/200 MHz Spread Spectrum differential true output clock 3. LOW when output is disabled. |
| 13 | $\overline{\text{CLK2}}$ | Output | Selectable 100/200 MHz Spread Spectrum differential compliment output clock 2. LOW when output is disabled. |
| 14 | CLK2 | Output | Selectable 100/200 MHz Spread Spectrum differential true output clock 2. LOW when output is disabled. |
| 15 | VDDO | Power | Output power supply, nominal 1.8V, range 1.05V~3.3V. |
| 16 | GND A | Power | Output and Analog circuit ground |
| 17 | $\overline{\text{CLK1}}$ | Output | Selectable 100/200 MHz Spread Spectrum differential compliment output clock 1. LOW when output is disabled. |
| 18 | CLK1 | Output | Selectable 100/200 MHz Spread Spectrum differential true output clock 1. LOW when output is disabled. |
| 19 | $\overline{\text{CLK0}}$ | Output | Selectable 100/200 MHz Spread Spectrum differential compliment output clock 0. LOW when output is disabled. |
| 20 | CLK0 | Output | Selectable 100/200 MHz Spread Spectrum differential true output clock 0. LOW when output is disabled. |

Table 2: Spread Selection Table

| S2 | S1 | S0 | Spread % | Spread Type | Output Frequency |
|----|----|----|-----------|----------------|------------------|
| 0 | 0 | 0 | -0.5 | Down | 100 |
| 0 | 0 | 1 | -1.0 | Down | 100 |
| 0 | 1 | 0 | -1.5 | Down | 100 |
| 0 | 1 | 1 | No Spread | Not Applicable | 100 |
| 1 | 0 | 0 | -0.5 | Down | 200 |
| 1 | 0 | 1 | -1.0 | Down | 200 |
| 1 | 1 | 0 | -1.5 | Down | 200 |
| 1 | 1 | 1 | No Spread | Not Applicable | 200 |

Test Loads

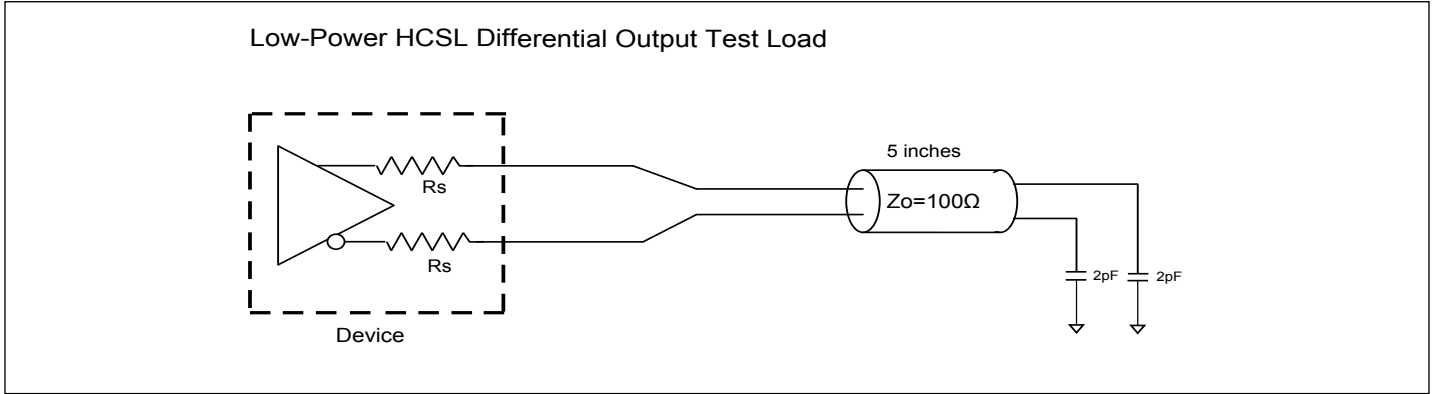

Driving LVDS

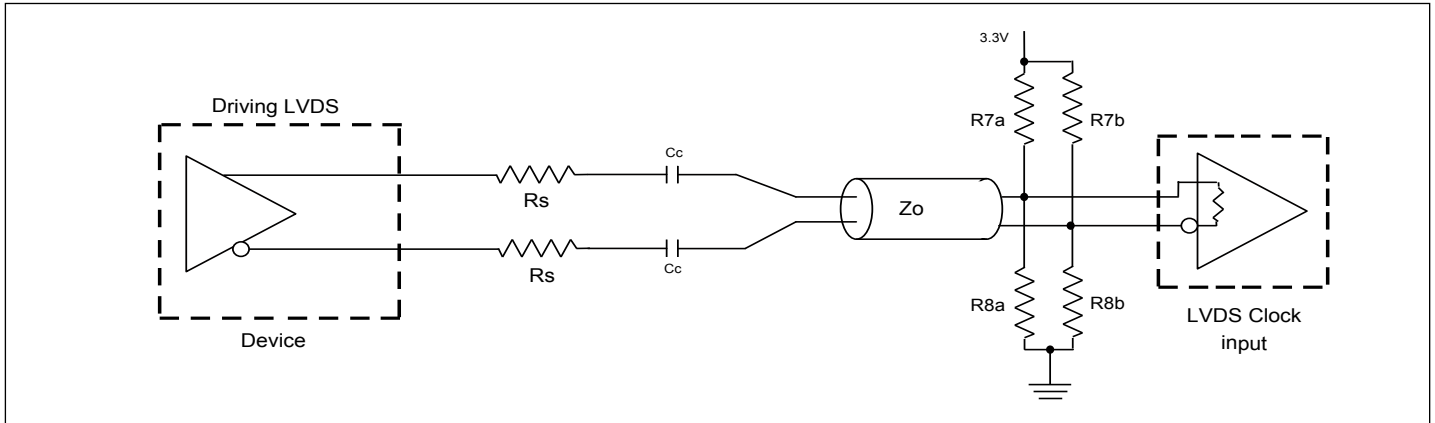

Driving LVDS inputs with the PI6CFGL402B

| Component | Value | |
|-----------|--------------------------|------------------------------------|
| | Receiver has termination | Receiver does not have termination |
| R7a, R7b | 10K Ω | 140 Ω |
| R8a, R8b | 5.6K Ω | 75 Ω |
| Cc | 0.1 uF | 0.1 uF |
| Vcm | 1.2 volts | 1.2 volts |

Maximum Ratings

(Above which useful life may be impaired. For user guidelines, not tested.)

| | |
|---|-------------------|
| Supply Voltage to Ground Potential..... | 4.6V |
| All Inputs and Output..... | -0.5V to VDD+0.5V |
| Ambient Operating Temperature..... | -40 to +85°C |
| Storage Temperature..... | -65°C to +150°C |
| Junction Temperature | 125°C |
| Soldering Temperature..... | 260°C |
| ESD Protection (Input) | 2000V(HBM) |

Note: Stresses greater than those listed under MAXIMUM RATINGS may cause permanent damage to the device. This is a stress rating only and functional operation of the device at these or any other conditions above those indicated in the operational sections of this specification is not implied. Exposure to absolute maximum rating conditions for extended periods may affect reliability.

Electrical Characteristics–Current Consumption

($T_A = -40\sim 85^\circ\text{C}$; Supply Voltage VDD = 3.3V +/-10%; VDDO = 1.8V +/-10%, See Test Loads for Loading Conditions)

| Symbol | Parameters | Condition | Min. | Type | Max. | Units |
|-------------------|---------------------------------------|---|------|------|------|-------|
| I _{DDOP} | Operating Supply Current ¹ | Total power consumption, All outputs active @100MHz | | | 60 | mA |

Notes:

1. Guaranteed by design and characterization, not 100% tested in production.

Electrical Characteristics–Input/Supply/Common Parameters–Normal Operating

Conditions ($T_A = -40\sim 85^\circ\text{C}$; Supply Voltage VDD = 3.3V +/-10%; VDDO = 1.8V +/-10%, See Test Loads for Loading Conditions)

| Symbol | Parameters | Condition | Min. | Type | Max. | Units |
|-----------------------|---------------------------------|---|-------------------------|------|--------------------------|-------|
| V _{DDX} | Supply Voltage ¹ | Supply voltage for core, analog | 3.0 | 3.3 | 3.6 | V |
| V _{DDO} | Supply Voltage ¹ | Supply voltage outputs | 1.65 | 1.8 | 2.0 | V |
| V _{IH} | Input High Voltage ¹ | OE, S0, S1, SS0, SS1 | 0.65 V _{DD} | | V _{DD} + 0.3 | V |
| V _{IL} | Input Low Voltage ¹ | OE, S0, S1, SS0, SS1 | -0.3 | | 0.35 V _{DD} | V |
| I _{IN} | Input Current ¹ | Single-ended inputs, V _{IN} = GND, V _{IN} = VDD (exclude XTAL pin) | -5 | | 5 | uA |
| I _{INP} | | Single-ended inputs V _{IN} = 0 V; Inputs with internal pull-up resistors V _{IN} = VDD; Inputs with internal pull-down resistors | -200 | | 200 | uA |
| F _{in} | Input Frequency ¹ | XTAL, or X1 input | 23 | 25 | 27 | MHz |
| L _{pin} | Pin Inductance ¹ | | | | 7 | nH |
| C _{IN} | Capacitance ^{1,4} | Logic Inputs, except DIF_IN | 1.5 | | 5 | pF |
| C _{INDIF_IN} | | DIF_IN differential clock inputs | 1.5 | | 2.7 | pF |
| C _{OUT} | | Output pin capacitance | | | 6 | pF |

| Symbol | Parameters | Condition | Min. | Type | Max. | Units |
|---------------------|--|---|------|--------|------|-------|
| T _{STAB} | Clk Stabilization ^{1,2} | From V _{DD} Power-Up and after input clock stabilization or de-assertion of PD# to 1st clock | | 0.6 | 1 | ms |
| f _{MODIN} | Input SS Modulation Frequency ¹ | Allowable Frequency (Triangular Modulation) | 30 | 31.500 | 33 | kHz |
| t _{OE} | Output Enable Time ¹ | All outputs | | | 10 | μs |
| t _{OT} | Output Disable Time ¹ | All outputs | | | 10 | μs |
| t _{STABLE} | From power-up to V _{DD} = 3.3V ¹ | From Power-up V _{DD} = 3.3V | | 3.0 | | ms |
| t _{SPREAD} | Setting period after spread change ¹ | Setting period after spread change | | 3.0 | | ms |

Note:

1. Guaranteed by design and characterization, not 100% tested in production.
2. Control input must be monotonic from 20% to 80% of input swing. Input Frequency Capacitance
3. Time from deassertion until outputs are >200 mV
4. DIF_IN input

Electrical Characteristics—CLK 0.7V Low Power HCSL Outputs (T_A = -40~85°C; Supply Voltage V_{DD} = 3.3V +/-10%; V_{DDO} = 1.8V +/-10%; 100MHz output frequency, See Test Loads for Loading Conditions)

| Symbol | Parameters | Condition | Min. | Type | Max. | Units |
|------------------------|---------------------------------------|---|------|------|------|-------|
| Trf | Slew rate ^{1,2,3} | | 1.1 | 2 | 4.5 | V/ns |
| V _{HIGH} | Voltage High ¹ | Statistical measurement on single-ended signal using oscilloscope math function. (Scope averaging on) | 660 | | 900 | mV |
| V _{LOW} | Voltage Low ¹ | | -150 | | 150 | mV |
| V _{max} | Max Voltage ¹ | Measurement on single ended signal using absolute value. (Scope averaging off) | | | 1150 | mV |
| V _{min} | Min Voltage ¹ | | -300 | | | mV |
| V _{swing} | V _{swing} ^{1,2} | Scope averaging off | 300 | | | mV |
| V _{cross_abs} | Crossing Voltage (abs) ^{1,5} | Scope averaging off | 250 | | 550 | mV |
| Δ-V _{cross} | Crossing Voltage (var) ^{1,6} | Scope averaging off | | | 140 | mV |
| t _{DC} | Duty Cycle ¹ | Measured differentially, PLL Mode | 45 | | 55 | % |
| t _{skew} | Skew, Output to Output ¹ | V _T = 50% | | | 50 | ps |
| t _{jyc-cyc} | Jitter, Cycle to cycle ^{1,2} | PLL mode | | | 50 | ps |

Note:

1. Guaranteed by design and characterization, not 100% tested in production.
2. Measured from differential waveform
3. Slew rate is measured through the V_{swing} voltage range centered around differential 0V. This results in a +/-150mV window around differential 0V.
4. Matching applies to rising edge rate for Clock and falling edge rate for Clock#. It is measured using a +/-75mV window centered on the average cross point where Clock rising meets Clock# falling. The median cross point is used to calculate the voltage thresholds the oscilloscope is to use for the edge rate calculations.
5. V_{cross} is defined as voltage where Clock = Clock# measured on a component test board and only applies to the differential rising edge (i.e. Clock rising and Clock# falling).
6. The total variation of all V_{cross} measurements in any particular system. Note that this is a subset of V_{cross_min/max} (V_{cross} absolute) allowed. The intent is to limit V_{cross} induced modulation by setting Δ-V_{cross} to be smaller than V_{cross} absolute.

Electrical Characteristics–Phase Jitter Parameters

($T_A = -40 \sim 85^\circ\text{C}$; Supply Voltage $V_{DD} = 3.3\text{V} \pm 10\%$; $V_{DDO} = 1.8\text{V} \pm 10\%$; 100MHz output frequency, See Test Loads for Loading Conditions)

| Symbol | Parameters | Condition | Min. | Type | Industry Limit | Units |
|-----------------|------------------------------|---|------|------|----------------|-------------|
| $t_{jphPCIeG1}$ | Phase Jitter, PCI Express | PCIe Gen 1 ^{1,2,3,5} | | 25 | 86 | ps (p-p) |
| $t_{jphPCIeG2}$ | | PCIe Gen 2 Low Band $10\text{kHz} < f < 1.5\text{MHz}$ ^{1,2,5} | | 0.9 | 3 | ps (rms) |
| | | PCIe Gen 2 High Band $1.5\text{MHz} < f < \text{Nyquist}$ (50MHz) ^{1,2,5} | | 1.6 | 3.1 | ps (rms) |
| $t_{jphPCIeG3}$ | | PCIe Gen 3 (PLL BW of 2-4MHz, CDR = 10MHz) ^{1,2,4,5} | | 0.36 | 1 | ps (rms) |

Notes:

1. Guaranteed by design and characterization, not 100% tested in production.
2. See <http://www.pcisig.com> for complete specs.
3. Sample size of at least 100k cycles. This figures extrapolates to 108ps pk-pk @ 1M cycles for a BER of 1-12.
4. Calculated from Intel-supplied Clock Jitter Tool.
5. Applies to all different outputs.

Application Notes

Crystal circuit connection

The following diagram shows crystal circuit connection with a parallel crystal. For the $CL=18\text{pF}$ crystal, it is suggested to use $C1=27\text{pF}$, $C2=27\text{pF}$. $C1$ and $C2$ can be adjusted to fine tune to the target ppm of crystal oscillator according to different board layouts.

Crystal Oscillator Circuit

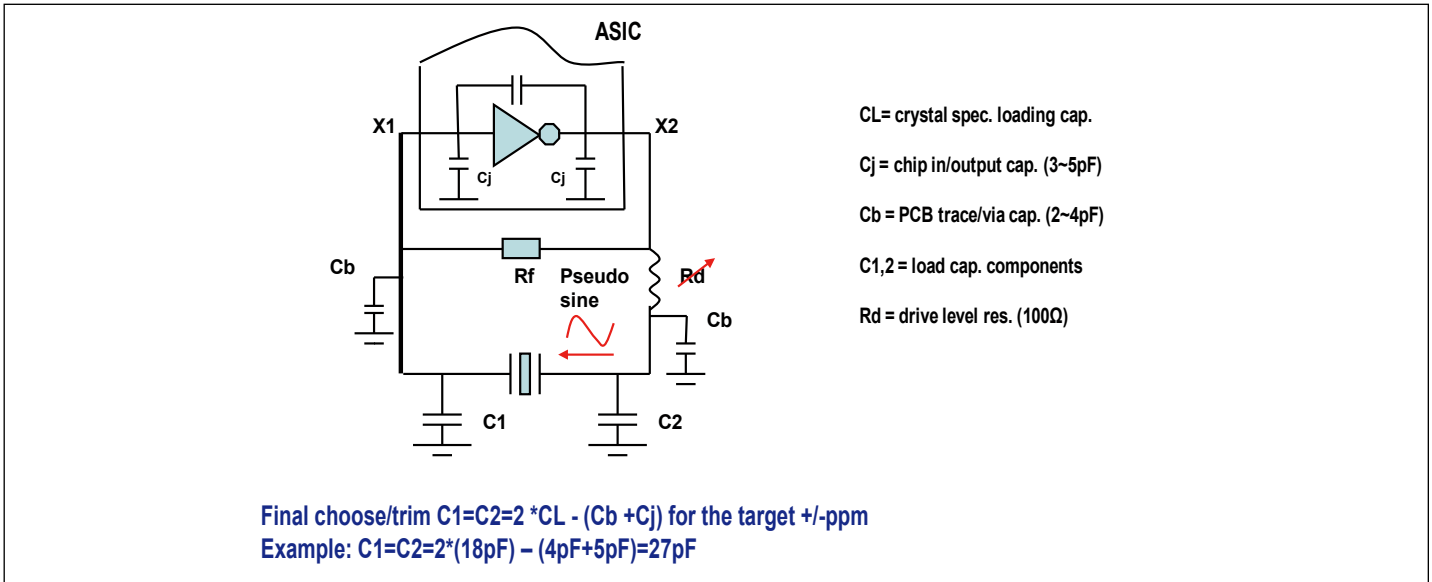
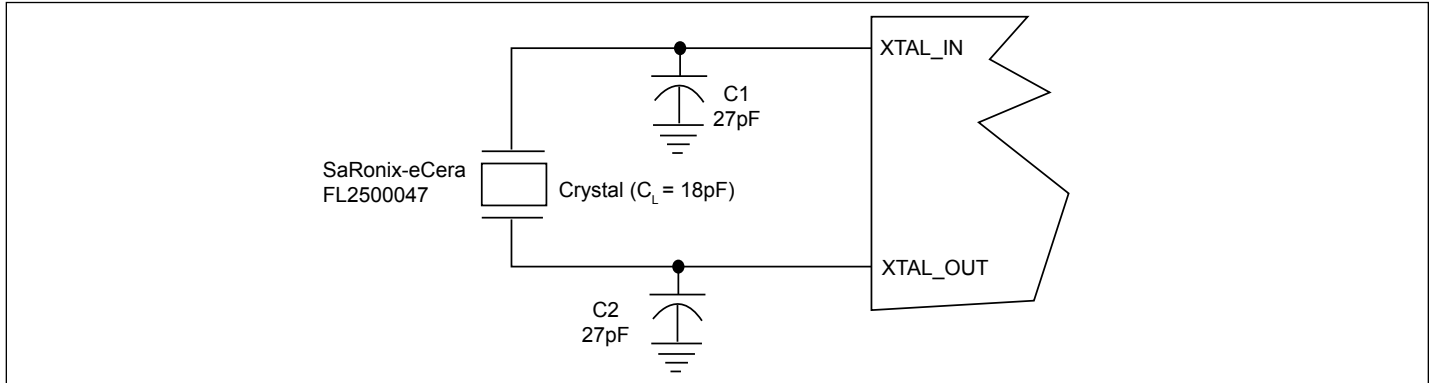

Recommended Crystal Specification

Pericom recommends:

- GC2500003 XTAL 49S/SMD(4.0 mm), 25M, $CL=18\text{pF}$, +/-30ppm, http://www.pericom.com/pdf/datasheets/se/GC_GF.pdf
- FY2500081, SMD 5x3.2(4P), 25M, $CL=18\text{pF}$, +/-30ppm, http://www.pericom.com/pdf/datasheets/se/FY_F9.pdf
- FL2500047, SMD 3.2x2.5(4P), 25M, $CL=18\text{pF}$, +/-20ppm, <http://www.pericom.com/pdf/datasheets/se/FL.pdf>

Packaging Mechanical: 20-pin TSSOP (L)

VARIATIONS (ALL DIMENSIONS SHOWN IN MM)

| SYMBOLS | MIN. | NOM. | MAX. |
|---------|----------|------|------|
| A | – | – | 1.20 |
| A1 | 0.05 | – | 0.15 |
| A2 | 0.80 | – | 1.05 |
| b | 0.19 | – | 0.30 |
| C | 0.09 | – | 0.20 |
| D | 6.40 | 6.50 | 6.60 |
| E1 | 4.30 | 4.40 | 4.50 |
| E | 6.40 BSC | | |
| e | 0.65 BSC | | |
| L1 | 1.00 REF | | |
| L | 0.45 | 0.60 | 0.75 |
| S | 0.20 | – | – |
| θ | 0° | – | 8° |

| | |
|---|--------------------|
| DESCRIPTION: 20-pin, 173mil Wide TSSOP | |
| PACKAGE CODE: L | |
| DOCUMENT CONTROL #: PD-1311 | REVISION: F |

Notes:

- Refer JEDEC MO-153F/AC
- Controlling dimensions in millimeters
- Package outline exclusive of mold flash and metal burr

12-0373

Ordering Information(1-3)

| Ordering Code | Package Code | Description |
|----------------|--------------|-----------------------------|
| PI6CFGL402BLIE | L | 20-Pin, 173mil Wide (TSSOP) |

Note:

- Thermal characteristics and package top marking information can be found at <http://www.pericom.com/packaging/>
- E = lead-free and green packaging
- Adding an X suffix = tape/reel