

## 16

# R8C/11 Group

## Hardware Manual

RENESAS 16-BIT SINGLE-CHIP MICROCOMPUTER  
M16C FAMILY/R8C/Tiny SERIES

All information contained in these materials, including products and product specifications, represents information on the product at the time of publication and is subject to change by Renesas Technology Corp. without notice. Please review the latest information published by Renesas Technology Corp. through various means, including the Renesas Technology Corp. website (<http://www.renesas.com>).

## Keep safety first in your circuit designs!

1. Renesas Technology Corp. puts the maximum effort into making semiconductor products better and more reliable, but there is always the possibility that trouble may occur with them. Trouble with semiconductors may lead to personal injury, fire or property damage. Remember to give due consideration to safety when making your circuit designs, with appropriate measures such as (i) placement of substitutive, auxiliary circuits, (ii) use of non-flammable material or (iii) prevention against any malfunction or mishap.

## Notes regarding these materials

1. These materials are intended as a reference to assist our customers in the selection of the Renesas Technology Corp. product best suited to the customer's application; they do not convey any license under any intellectual property rights, or any other rights, belonging to Renesas Technology Corp. or a third party.
2. Renesas Technology Corp. assumes no responsibility for any damage, or infringement of any third-party's rights, originating in the use of any product data, diagrams, charts, programs, algorithms, or circuit application examples contained in these materials.
3. All information contained in these materials, including product data, diagrams, charts, programs and algorithms represents information on products at the time of publication of these materials, and are subject to change by Renesas Technology Corp. without notice due to product improvements or other reasons. It is therefore recommended that customers contact Renesas Technology Corp. or an authorized Renesas Technology Corp. product distributor for the latest product information before purchasing a product listed herein. The information described here may contain technical inaccuracies or typographical errors. Renesas Technology Corp. assumes no responsibility for any damage, liability, or other loss rising from these inaccuracies or errors. Please also pay attention to information published by Renesas Technology Corp. by various means, including the Renesas Technology Corp. Semiconductor home page (<http://www.renesas.com>).
4. When using any or all of the information contained in these materials, including product data, diagrams, charts, programs, and algorithms, please be sure to evaluate all information as a total system before making a final decision on the applicability of the information and products. Renesas Technology Corp. assumes no responsibility for any damage, liability or other loss resulting from the information contained herein.
5. Renesas Technology Corp. semiconductors are not designed or manufactured for use in a device or system that is used under circumstances in which human life is potentially at stake. Please contact Renesas Technology Corp. or an authorized Renesas Technology Corp. product distributor when considering the use of a product contained herein for any specific purposes, such as apparatus or systems for transportation, vehicular, medical, aerospace, nuclear, or undersea repeater use.
6. The prior written approval of Renesas Technology Corp. is necessary to reprint or reproduce in whole or in part these materials.
7. If these products or technologies are subject to the Japanese export control restrictions, they must be exported under a license from the Japanese government and cannot be imported into a country other than the approved destination. Any diversion or reexport contrary to the export control laws and regulations of Japan and/or the country of destination is prohibited.
8. Please contact Renesas Technology Corp. for further details on these materials or the products contained therein.

# How to Use This Manual

## 1. Introduction

This hardware manual provides detailed information on the R8C/11 Group of microcomputers. Users are expected to have basic knowledge of electric circuits, logical circuits and microcomputers.

## 2. Register Diagram

The symbols, and descriptions, used for bit function in each register are shown below.

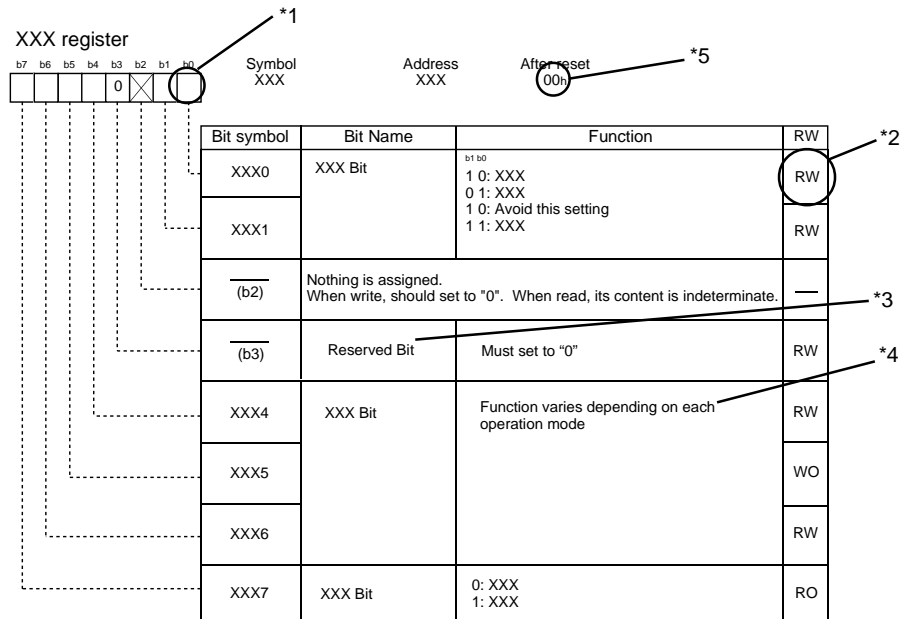

\*1

Blank: Set to "0" or "1" according to the application

0: Set to "0"

1: Set to "1"

X: Nothing is assigned

\*2

RW: Read and write

RO: Read only

WO: Write only

-: Nothing is assigned

\*3

•Reserved bit

Reserved bit. Set to specified value.

\*4

•Nothing is assigned

Nothing is assigned to the bit concerned. As the bit may be use for future functions, set to "0" when writing to this bit.

•Do not set to this value

The operation is not guaranteed when a value is set.

•Function varies depending on mode of operation

Bit function varies depending on peripheral function mode.

Refer to respective register for each mode.

\*5

Follow the text in each manual for binary and hexadecimal notations.

### 3. M16C Family Documents

The following documents were prepared for the M16C family.<sup>(1)</sup>

Document	Contents
Short Sheet	Hardware overview
Data Sheet	Hardware overview and electrical characteristics
Hardware Manual	Hardware specifications (pin assignments, memory maps, peripheral specifications, electrical characteristics, timing charts). *Refer to the application note for how to use peripheral functions.
Software Manual	Detailed description of assembly instructions and microcomputer performance of each instruction
Application Note	<ul style="list-style-type: none"><li>• Usage and application examples of peripheral functions</li><li>• Sample programs</li><li>• Introduction to the basic functions in the M16C family</li><li>• Programming method with Assembly and C languages</li></ul>
RENESAS TECHNICAL UPDATE	Preliminary report about the specification of a product, a document, etc.

NOTES:

1. Before using this material, please visit the our website to verify that this is the most updated document available.

# Table of Contents

## SFR Page Reference

<b>Chapter 1. Overview</b> .....	<b>1</b>
1.1 Applications .....	1
1.2 Performance Overview .....	2
1.3 Block Diagram .....	3
1.4 Product Information .....	4
1.5 Pin Assignments .....	5
1.6 Pin Description .....	6
<b>Chapter 2. Central Processing Unit (CPU)</b> .....	<b>7</b>
2.1 Data Registers (R0, R1, R2 and R3) .....	7
2.2 Address Registers (A0 and A1) .....	8
2.3 Frame Base Register (FB) .....	8
2.4 Interrupt Table Register (INTB) .....	8
2.5 Program Counter (PC) .....	8
2.6 User Stack Pointer (USP) and Interrupt Stack Pointer (ISP) .....	8
2.7 Static Base Register (SB) .....	8
2.8 Flag Register (FLG) .....	8
2.8.1 Carry Flag (C Flag) .....	8
2.8.2 Debug Flag (D Flag) .....	8
2.8.3 Zero Flag (Z Flag) .....	8
2.8.4 Sign Flag (S Flag) .....	8
2.8.5 Register Bank Select Flag (B Flag) .....	8
2.8.6 Overflow Flag (O Flag) .....	8
2.8.7 Interrupt Enable Flag (I Flag) .....	8
2.8.8 Stack Pointer Select Flag (U Flag) .....	8
2.8.9 Processor Interrupt Priority Level (IPL) .....	8
2.8.10 Reserved Area .....	8
<b>Chapter 3. Memory</b> .....	<b>9</b>
<b>Chapter 4. Special Function Registers (SFR)</b> .....	<b>10</b>
<b>Chapter 5. Reset</b> .....	<b>14</b>
5.1 Hardware Reset .....	14
5.1.1 Hardware Reset 1 .....	14
5.1.2 Hardware Reset 2 .....	17
5.1.3 Power-on Reset Function .....	18
5.2 Software Reset .....	20
5.3 Watchdog Timer Reset .....	20

5.4 Voltage Detection Circuit .....	21
5.4.1 Voltage Detection Interrupt .....	26
5.4.2 Exiting Stop Mode on a Voltage Detection Interrupt .....	28
<b>Chapter 6. Clock Generation Circuit.....</b>	<b>29</b>
6.1 Main Clock.....	34
6.2 On-Chip Oscillator Clock .....	35
6.2.1 Low-Speed On-Chip Oscillator .....	35
6.2.2 High-Speed On-Chip Oscillator .....	35
6.3 CPU Clock and Peripheral Function Clock .....	36
6.3.1 CPU Clock.....	36
6.3.2 Peripheral Function Clock (f1, f2, f8, f32, fAD, f1SIO, f8SIO, f32SIO) .....	36
6.3.3 fRING and fRING128 .....	36
6.3.4 fRING-fast .....	36
6.4 Power Control .....	37
6.4.1 Normal Operation Mode .....	37
6.4.2 Wait Mode .....	39
6.4.3 Stop Mode .....	40
6.5 Oscillation Stop Detection Function .....	42
6.5.1 How to Use Oscillation Stop Detection Function .....	42
<b>Chapter 7. Protection .....</b>	<b>44</b>
<b>Chapter 8. Processor Mode .....</b>	<b>45</b>
8.1 Types of Processor Mode .....	45
<b>Chapter 9. Bus .....</b>	<b>46</b>
<b>Chapter 10. Interrupt .....</b>	<b>47</b>
10.1 Interrupt Overview .....	47
10.1.1 Type of Interrupts .....	47
10.1.2 Software Interrupts .....	48
10.1.3 Hardware Interrupts .....	49
10.1.4 Interrupts and Interrupt Vector .....	50
10.1.5 Interrupt Control .....	52
10.2 $\overline{\text{INT}}$ Interrupt .....	60
10.2.1 $\overline{\text{INT0}}$ Interrupt .....	60
10.2.2 $\overline{\text{INT0}}$ Input Filter .....	61
10.2.3 $\overline{\text{INT1}}$ Interrupt and $\overline{\text{INT2}}$ Interrupt .....	62
10.2.4 $\overline{\text{INT3}}$ Interrupt .....	63
10.3 Key Input Interrupt .....	65
10.4 Address Match Interrupt .....	66
<b>Chapter 11. Watchdog Timer .....</b>	<b>68</b>
<b>Chapter 12. Timers .....</b>	<b>70</b>
12.1 Timer X .....	71
12.1.1 Timer Mode .....	73

12.1.2 Pulse Output Mode .....	74
12.1.3 Event Counter Mode .....	75
12.1.4 Pulse Width Measurement Mode .....	76
12.1.5 Pulse Period Measurement Mode .....	78
<b>12.2 Timer Y .....</b>	<b>80</b>
12.2.1 Timer Mode .....	83
12.2.2 Programmable Waveform Generation Mode .....	85
<b>12.3 Timer Z .....</b>	<b>88</b>
12.3.1 Timer Mode .....	91
12.3.2 Programmable Waveform Generation Mode .....	93
12.3.3 Programmable One-shot Generation Mode .....	95
12.3.4 Programmable Wait One-shot Generation Mode .....	98
<b>12.4 Timer C .....</b>	<b>101</b>
12.4.1 Input Capture Mode .....	105
12.4.2 Output Compare Mode .....	107
<b>Chapter 13. Serial Interface .....</b>	<b>109</b>
13.1 Clock Synchronous Serial I/O Mode .....	114
13.1.1 Polarity Select Function .....	117
13.1.2 LSB First/MSB First Select Function .....	117
13.1.3 Continuous Receive Mode .....	118
13.2 Clock Asynchronous Serial I/O (UART) Mode .....	119
13.2.1 TxD10/RxD1 Select Function (UART1) .....	122
13.2.2 TxD11 Select Function (UART1) .....	122
13.2.3 Bit Rate .....	123
<b>Chapter 14. A/D Converter .....</b>	<b>124</b>
14.1 One-shot Mode .....	128
14.2 Repeat Mode .....	130
14.3 Sample and Hold .....	132
14.4 A/D conversion cycles .....	132
14.5 Internal Equivalent Circuit of Analog Input .....	133
14.6 Inflow Current Bypass Circuit .....	134
14.7 Output Impedance of Sensor under A/D Conversion .....	135
<b>Chapter 15. Programmable I/O Ports .....</b>	<b>137</b>
15.1 Description .....	137
15.1.1 Port Pi Direction Register (PDi Register, i=0,1,3,4) .....	137
15.1.2 Port Pi Register (Pi Register, i=0 to 4) .....	137
15.1.3 Pull-up Control Register 0, Pull-up Control Register 1 (PUR0 and PUR1 Registers) .....	137
15.1.4 Port P1 Drive Capacity Control Register (DRR Register) .....	137
15.2 Port setting .....	145
15.3 Unassigned Pin Handling .....	151
<b>Chapter 16. Electrical Characteristics .....</b>	<b>152</b>
<b>Chapter 17. Flash Memory Version .....</b>	<b>164</b>

17.1 Overview .....	164
17.2 Memory Map .....	165
17.3 Functions To Prevent Flash Memory from Rewriting.....	166
17.3.1 ID Code Check Function .....	166
17.4 CPU Rewrite Mode .....	167
17.4.1 EW0 Mode .....	168
17.4.2 EW1 Mode .....	168
17.4.3 Software Commands .....	174
17.4.4 Status Register .....	178
17.4.5 Full Status Check .....	179
17.5 Standard Serial I/O Mode .....	181
17.5.1 ID Code Check Function .....	181
<b>Chapter 18. On-chip Debugger .....</b>	<b>185</b>
18.1 Address Match Interrupt .....	185
18.2 Single Step Interrupt .....	185
18.3 UART1 .....	185
18.4 BRK Instruction .....	188
<b>Chapter 19. Usage Notes .....</b>	<b>186</b>
19.1 Stop Mode and Wait Mode .....	186
19.1.1 Stop Mode .....	186
19.1.2 Wait Mode .....	186
19.2 Interrupts .....	187
19.2.1 Reading Address 00000 <sub>16</sub> .....	187
19.2.2 SP Setting .....	187
19.2.3 External Interrupt and Key Input Interrupt .....	187
19.2.4 Watchdog Timer Interrupt .....	187
19.2.5 Changing Interrupt Factor .....	188
19.2.6 Changing Interrupt Control Register .....	189
19.3 Clock Generation Circuit .....	190
19.3.1 Oscillation Stop Detection Function .....	190
19.3.2 Oscillation Circuit Constants .....	190
19.4 Timers .....	191
19.3.1 Timers X, Y and Z .....	191
19.3.2 Timer X .....	19
19.3.3 Timer Y .....	191
19.3.4 Timer Z .....	191
19.3.5 Timer C .....	191
19.5 Serial Interface .....	192
19.6 A/D Converter .....	193
19.7 Flash Memory Version .....	194
19.7.1 CPU Rewrite Mode .....	194
19.8 Noise .....	197
<b>Chapter 20. Usage Notes for On-chip Debugger .....</b>	<b>198</b>



<b>Appendix 1 Package Dimensions .....</b>	<b>199</b>
<b>Appendix 2 Connecting Examples for Serial Writer and On-chip Debugging Emulator .....</b>	<b>200</b>
<b>Appendix 3 Example of Oscillation Evaluation Circuit..</b>	<b>202</b>
<b>Register Index .....</b>	<b>203</b>

## SFR Page Reference

Address	Register	Symbol	Page
0000 <sub>16</sub>			
0001 <sub>16</sub>			
0002 <sub>16</sub>			
0003 <sub>16</sub>			
0004 <sub>16</sub>	Processor mode register 0	PM0	45
0005 <sub>16</sub>	Processor mode register 1	PM1	45
0006 <sub>16</sub>	System clock control register 0	CM0	31
0007 <sub>16</sub>	System clock control register 1	CM1	31
0008 <sub>16</sub>	High-speed on-chip oscillator control register 0	HR0	33
0009 <sub>16</sub>	Address match interrupt enable register	AIER	67
000A <sub>16</sub>	Protect register	PRCR	44
000B <sub>16</sub>	High-speed on-chip oscillator control register 1	HR1	33
000C <sub>16</sub>	Oscillation stop detection register	OCD	32
000D <sub>16</sub>	Watchdog timer reset register	WDTR	69
000E <sub>16</sub>	Watchdog timer start register	WDTS	69
000F <sub>16</sub>	Watchdog timer control register	WDC	69
0010 <sub>16</sub>	Address match interrupt register 0	RMAD0	67
0011 <sub>16</sub>			
0012 <sub>16</sub>			
0013 <sub>16</sub>	Address match interrupt register 1	RMAD1	67
0014 <sub>16</sub>			
0015 <sub>16</sub>			
0016 <sub>16</sub>			
0017 <sub>16</sub>			
0018 <sub>16</sub>			
0019 <sub>16</sub>	Voltage detection register 1	VCR1	22
001A <sub>16</sub>	Voltage detection register 2	VCR2	22
001B <sub>16</sub>			
001C <sub>16</sub>			
001D <sub>16</sub>			
001E <sub>16</sub>	INT0 input filter select register	INTOF	60
001F <sub>16</sub>	Voltage detection interrupt register	D4INT	23
0020 <sub>16</sub>			
0021 <sub>16</sub>			
0022 <sub>16</sub>			
0023 <sub>16</sub>			
0024 <sub>16</sub>			
0025 <sub>16</sub>			
0026 <sub>16</sub>			
0027 <sub>16</sub>			
0028 <sub>16</sub>			
0029 <sub>16</sub>			
002A <sub>16</sub>			
002B <sub>16</sub>			
002C <sub>16</sub>			
002D <sub>16</sub>			
002E <sub>16</sub>			
002F <sub>16</sub>			
0030 <sub>16</sub>			
0031 <sub>16</sub>			
0032 <sub>16</sub>			
0033 <sub>16</sub>			
0034 <sub>16</sub>			
0035 <sub>16</sub>			
0036 <sub>16</sub>			
0037 <sub>16</sub>			
0038 <sub>16</sub>			
0039 <sub>16</sub>			
003A <sub>16</sub>			
003B <sub>16</sub>			
003C <sub>16</sub>			
003D <sub>16</sub>			
003E <sub>16</sub>			
003F <sub>16</sub>			

Address	Register	Symbol	Page
0040 <sub>16</sub>			
0041 <sub>16</sub>			
0042 <sub>16</sub>			
0043 <sub>16</sub>			
0044 <sub>16</sub>			
0045 <sub>16</sub>			
0046 <sub>16</sub>			
0047 <sub>16</sub>			
0048 <sub>16</sub>			
0049 <sub>16</sub>			
004A <sub>16</sub>			
004B <sub>16</sub>			
004C <sub>16</sub>			
004D <sub>16</sub>	Key input interrupt control register	KUPIC	53
004E <sub>16</sub>	AD conversion interrupt control register	ADIC	53
004F <sub>16</sub>			
0050 <sub>16</sub>	Compare 1 interrupt control register	CMP1IC	53
0051 <sub>16</sub>	UART0 transmit interrupt control register	S0TIC	53
0052 <sub>16</sub>	UART0 receive interrupt control register	S0RIC	53
0053 <sub>16</sub>	UART1 transmit interrupt control register	S1TIC	53
0054 <sub>16</sub>	UART1 receive interrupt control register	S1RIC	53
0055 <sub>16</sub>	INT2 interrupt control register	INT2IC	53
0056 <sub>16</sub>	Timer X interrupt control register	TXIC	53
0057 <sub>16</sub>	Timer Y interrupt control register	TYIC	53
0058 <sub>16</sub>	Timer Z interrupt control register	TZIC	53
0059 <sub>16</sub>	INT1 interrupt control register	INT1IC	53
005A <sub>16</sub>	INT3 interrupt control register	INT3IC	53
005B <sub>16</sub>	Timer C interrupt control register	TCIC	53
005C <sub>16</sub>	Compare 0 interrupt control register	CMP0IC	53
005D <sub>16</sub>	INT0 interrupt control register	INT0IC	53
005E <sub>16</sub>			
005F <sub>16</sub>			
0060 <sub>16</sub>			
0061 <sub>16</sub>			
0062 <sub>16</sub>			
0063 <sub>16</sub>			
0064 <sub>16</sub>			
0065 <sub>16</sub>			
0066 <sub>16</sub>			
0067 <sub>16</sub>			
0068 <sub>16</sub>			
0069 <sub>16</sub>			
006A <sub>16</sub>			
006B <sub>16</sub>			
006C <sub>16</sub>			
006D <sub>16</sub>			
006E <sub>16</sub>			
006F <sub>16</sub>			
0070 <sub>16</sub>			
0071 <sub>16</sub>			
0072 <sub>16</sub>			
0073 <sub>16</sub>			
0074 <sub>16</sub>			
0075 <sub>16</sub>			
0076 <sub>16</sub>			
0077 <sub>16</sub>			
0078 <sub>16</sub>			
0079 <sub>16</sub>			
007A <sub>16</sub>			
007B <sub>16</sub>			
007C <sub>16</sub>			
007D <sub>16</sub>			
007E <sub>16</sub>			
007F <sub>16</sub>			

Blank columns are all reserved space. No use is allowed.

## SFR Page Reference

Address	Register	Symbol	Page
0080 <sub>16</sub>	Timer Y, Z mode register	TYZMR	80/88
0081 <sub>16</sub>	Prescaler Y	PREY	81
0082 <sub>16</sub>	Timer Y secondary	TYSC	81
0083 <sub>16</sub>	Timer Y primary	TYPR	81
0084 <sub>16</sub>	Timer Y, Z waveform output control register	PUM	82/90
0085 <sub>16</sub>	Prescaler Z	PREZ	89
0086 <sub>16</sub>	Timer Z secondary	TZSC	89
0087 <sub>16</sub>	Timer Z primary	TZPR	89
0088 <sub>16</sub>			
0089 <sub>16</sub>			
008A <sub>16</sub>	Timer Y, Z output control register	TYZOC	81/89
008B <sub>16</sub>	Timer X mode register	TXMR	71
008C <sub>16</sub>	Prescaler X	PREX	72
008D <sub>16</sub>	Timer X register	TX	72
008E <sub>16</sub>	Timer count source setting register	TCSS	72/82/90
008F <sub>16</sub>			
0090 <sub>16</sub>	Timer C register	TC	103
0091 <sub>16</sub>			
0092 <sub>16</sub>			
0093 <sub>16</sub>			
0094 <sub>16</sub>			
0095 <sub>16</sub>			
0096 <sub>16</sub>	External input enable register	INTEN	60
0097 <sub>16</sub>			
0098 <sub>16</sub>	Key input enable register	KIEN	65
0099 <sub>16</sub>			
009A <sub>16</sub>	Timer C control register 0	TCC0	103
009B <sub>16</sub>	Timer C control register 1	TCC1	104
009C <sub>16</sub>	Capture and compare 0 register	TM0	103
009D <sub>16</sub>			
009E <sub>16</sub>	Compare 1 register	TM1	103
009F <sub>16</sub>			
00A0 <sub>16</sub>	UART0 transmit/receive mode register	U0MR	112
00A1 <sub>16</sub>	UART0 bit rate register	U0BRG	111
00A2 <sub>16</sub>	UART0 transmit buffer register	U0TB	111
00A3 <sub>16</sub>			
00A4 <sub>16</sub>	UART0 transmit/receive control register 0	U0C0	112
00A5 <sub>16</sub>	UART0 transmit/receive control register 1	U0C1	113
00A6 <sub>16</sub>	UART0 receive buffer register	U0RB	111
00A7 <sub>16</sub>			
00A8 <sub>16</sub>	UART1 transmit/receive mode register	U1MR	112
00A9 <sub>16</sub>	UART1 bit rate register	U1BRG	111
00AA <sub>16</sub>	UART1 transmit buffer register	U1TB	111
00AB <sub>16</sub>			
00AC <sub>16</sub>	UART1 transmit/receive control register 0	U1C0	112
00AD <sub>16</sub>	UART1 transmit/receive control register 1	U1C1	113
00AE <sub>16</sub>	UART1 receive buffer register	U1RB	111
00AF <sub>16</sub>			
00B0 <sub>16</sub>	UART transmit/receive control register 2	UCON	113
00B1 <sub>16</sub>			
00B2 <sub>16</sub>			
00B3 <sub>16</sub>			
00B4 <sub>16</sub>			
00B5 <sub>16</sub>			
00B6 <sub>16</sub>			
00B7 <sub>16</sub>			
00B8 <sub>16</sub>			
00B9 <sub>16</sub>			
00BA <sub>16</sub>			
00BB <sub>16</sub>			
00BC <sub>16</sub>			
00BD <sub>16</sub>			
00BE <sub>16</sub>			
00BF <sub>16</sub>			

Blank columns are all reserved space. No use is allowed.

Address	Register	Symbol	Page
00C0 <sub>16</sub>	AD register	AD	127
00C1 <sub>16</sub>			
00C2 <sub>16</sub>			
00C3 <sub>16</sub>			
00C4 <sub>16</sub>			
00C5 <sub>16</sub>			
00C6 <sub>16</sub>			
00C7 <sub>16</sub>			
00C8 <sub>16</sub>			
00C9 <sub>16</sub>			
00CA <sub>16</sub>			
00CB <sub>16</sub>			
00CC <sub>16</sub>			
00CD <sub>16</sub>			
00CE <sub>16</sub>			
00CF <sub>16</sub>			
00D0 <sub>16</sub>			
00D1 <sub>16</sub>			
00D2 <sub>16</sub>			
00D3 <sub>16</sub>			
00D4 <sub>16</sub>	AD control register 2	ADCON2	127
00D5 <sub>16</sub>			
00D6 <sub>16</sub>	AD control register 0	ADCON0	126
00D7 <sub>16</sub>	AD control register 1	ADCON1	126
00D8 <sub>16</sub>			
00D9 <sub>16</sub>			
00DA <sub>16</sub>			
00DB <sub>16</sub>			
00DC <sub>16</sub>			
00DD <sub>16</sub>			
00DE <sub>16</sub>			
00DF <sub>16</sub>			
00E0 <sub>16</sub>	Port P0 register	P0	143
00E1 <sub>16</sub>	Port P1 register	P1	143
00E2 <sub>16</sub>	Port P0 direction register	PD0	143
00E3 <sub>16</sub>	Port P1 direction register	PD1	143
00E4 <sub>16</sub>			
00E5 <sub>16</sub>	Port P3 register	P3	143
00E6 <sub>16</sub>			
00E7 <sub>16</sub>	Port P3 direction register	PD3	143
00E8 <sub>16</sub>	Port P4 register	P4	143
00E9 <sub>16</sub>			
00EA <sub>16</sub>	Port P4 direction register	PD4	143
00EB <sub>16</sub>			
00EC <sub>16</sub>			
00ED <sub>16</sub>			
00EE <sub>16</sub>			
00EF <sub>16</sub>			
00F0 <sub>16</sub>			
00F1 <sub>16</sub>			
00F2 <sub>16</sub>			
00F3 <sub>16</sub>			
00F4 <sub>16</sub>			
00F5 <sub>16</sub>			
00F6 <sub>16</sub>			
00F7 <sub>16</sub>			
00F8 <sub>16</sub>			
00F9 <sub>16</sub>			
03FA <sub>16</sub>			
00FB <sub>16</sub>			
00FC <sub>16</sub>	Pull-up control register 0	PUR0	144
00FD <sub>16</sub>	Pull-up control register 1	PUR1	144
00FE <sub>16</sub>	Port P1 drive capacity control register	DRR	144
00FF <sub>16</sub>	Timer C output control register	TCOUT	106
01B3 <sub>16</sub>	Flash memory control register 4	FMR4	171
01B4 <sub>16</sub>			
01B5 <sub>16</sub>	Flash memory control register 1	FMR1	171
01B6 <sub>16</sub>			
01B7 <sub>16</sub>	Flash memory control register 0	FMR0	170

## 1. Overview

This MCU is built using the high-performance silicon gate CMOS process using a R8C/Tiny Series CPU core and is packaged in a 32-pin plastic molded LQFP. This MCU operates using sophisticated instructions featuring a high level of instruction efficiency. With 1M bytes of address space, it is capable of executing instructions at high speed.

### 1.1 Applications

Electric household appliance, office equipment, housing equipment (sensor, security), general industrial equipment, audio, etc.

## 1.2 Performance Overview

Table 1.1. lists the performance outline of this MCU.

**Table 1.1 Performance outline**

Item		Performance
CPU	Number of basic instructions	89 instructions
	Minimum instruction execution time	50 ns ( $f(X_{IN}) = 20$ MHz, $V_{CC} = 3.0$ to 5.5 V) 100 ns ( $f(X_{IN}) = 10$ MHz, $V_{CC} = 2.7$ to 5.5 V)
	Operating mode	Single-chip
	Address space	1M bytes
	Memory capacity	See Table 1.2.
Peripheral function	Port	Input/Output: 22 (including LED drive port), Input: 2
	LED drive port	I/O port: 8
	Timer	Timer X: 8 bits x 1 channel, Timer Y: 8 bits x 1 channel, Timer Z: 8 bits x 1 channel (Each timer equipped with 8-bit prescaler) Timer C: 16 bits x 1 channel (Circuits of input capture and output compare)
	Serial Interface	•1 channel Clock synchronous, UART •1 channel UART
	A/D converter	10-bit A/D converter: 1 circuit, 12 channels
	Watchdog timer	15 bits x 1 (with prescaler)
	Interrupt	Internal: 11 factors, External: 5 factors, Software: 4 factors, Priority level: 7 levels
	Clock generation circuit	2 circuits •Main clock generation circuit (Equipped with a built-in feedback resistor) •On-chip oscillator (high speed, low speed) On High-speed on-chip oscillator the frequency adjustment function is usable.
	Oscillation stop detection function	Main clock oscillation stop detection function
	Voltage detection circuit	Included
	Power on reset circuit	Included
Electrical characteristics	Supply voltage	$V_{CC} = 3.0$ to 5.5 V ( $f(X_{IN}) = 20$ MHz) $V_{CC} = 2.7$ to 5.5 V ( $f(X_{IN}) = 10$ MHz)
	Power consumption	Typ. 9 mA ( $V_{CC} = 5.0$ V, ( $f(X_{IN}) = 20$ MHz) Typ. 5 mA ( $V_{CC} = 3.0$ V, ( $f(X_{IN}) = 10$ MHz) Typ. 35 $\mu$ A ( $V_{CC} = 3.0$ V, Wait mode, Peripheral clock off) Typ. 0.7 $\mu$ A ( $V_{CC} = 3.0$ V, Stop mode)
Flash memory	Program/erase supply voltage	$V_{CC} = 2.7$ to 5.5 V
	Program/erase endurance	100 times
Operating ambient temperature		-20 to 85 °C -40 to 85 °C (D-version)
Package		32-pin plastic mold LQFP

### 1.3 Block Diagram

Figure 1.1 shows this MCU block diagram.

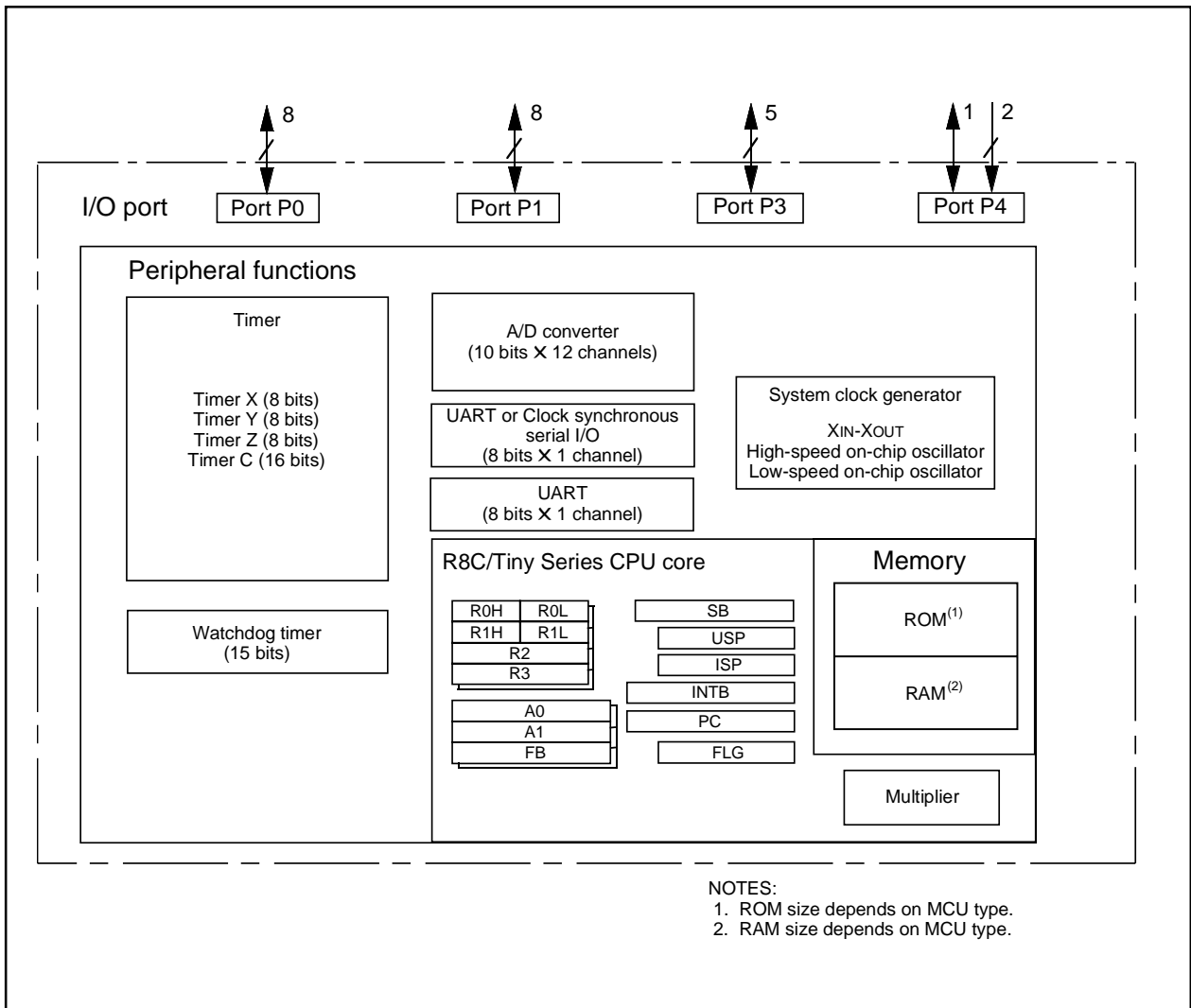

Figure 1.1 Block Diagram

### 1.4 Product Information

Table 1.2 lists the product information.

**Table 1.2 Product Information**

As of January 2006

Type No.	ROM capacity	RAM capacity	Package type	Remarks
R5F21112FP	8K bytes	512 bytes	PLQP0032GB-A	Flash memory version
R5F21113FP	12K bytes	768 bytes	PLQP0032GB-A	
R5F21114FP	16K bytes	1K bytes	PLQP0032GB-A	
R5F21112DFP	8K bytes	512 bytes	PLQP0032GB-A	D version
R5F21113DFP	12K bytes	768 bytes	PLQP0032GB-A	
R5F21114DFP	16K bytes	1K bytes	PLQP0032GB-A	

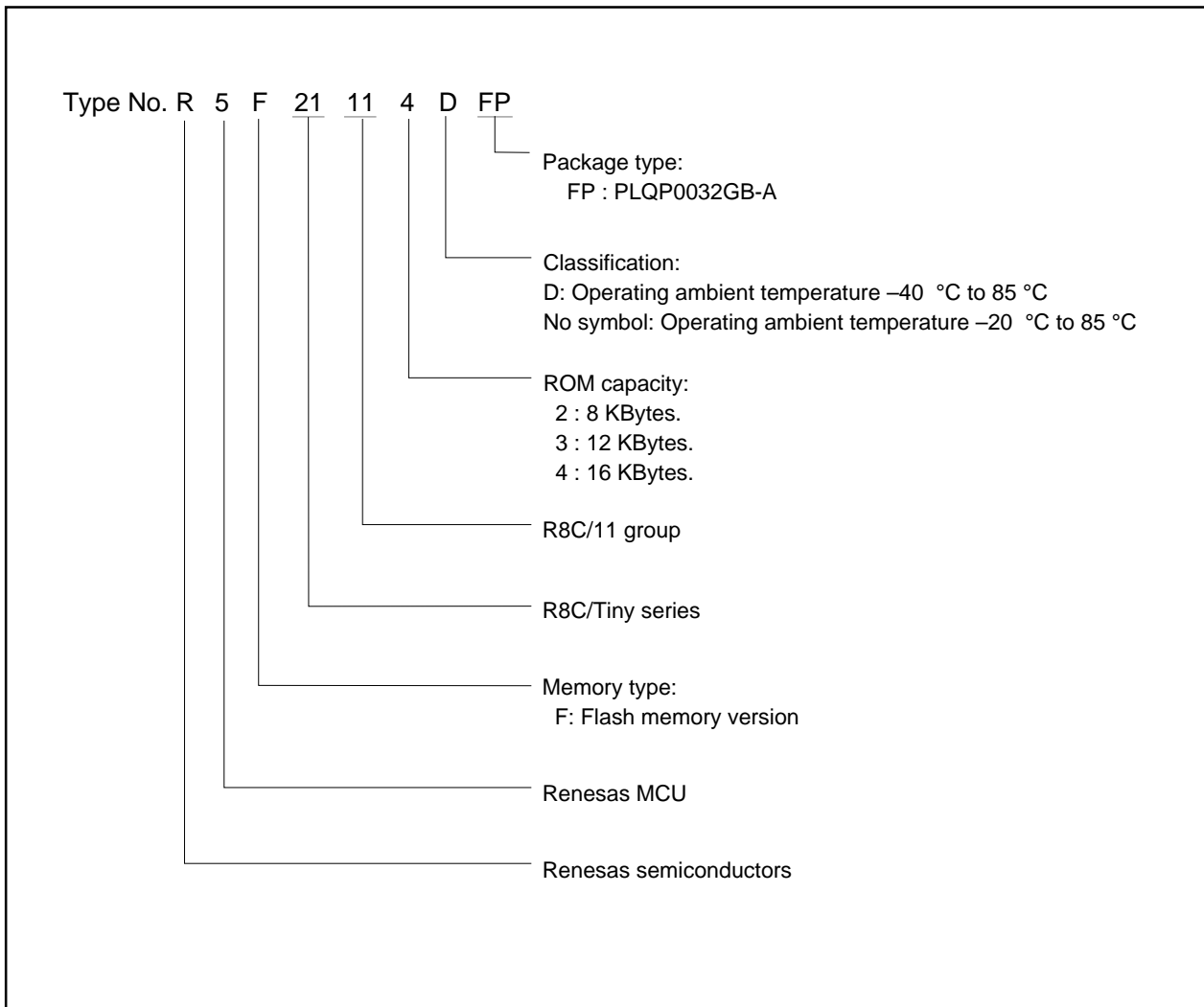

**Figure 1.2 Type No., Memory Size, and Package**

### 1.5 Pin Assignments

Figure 1.3 shows the pin configuration (top view).

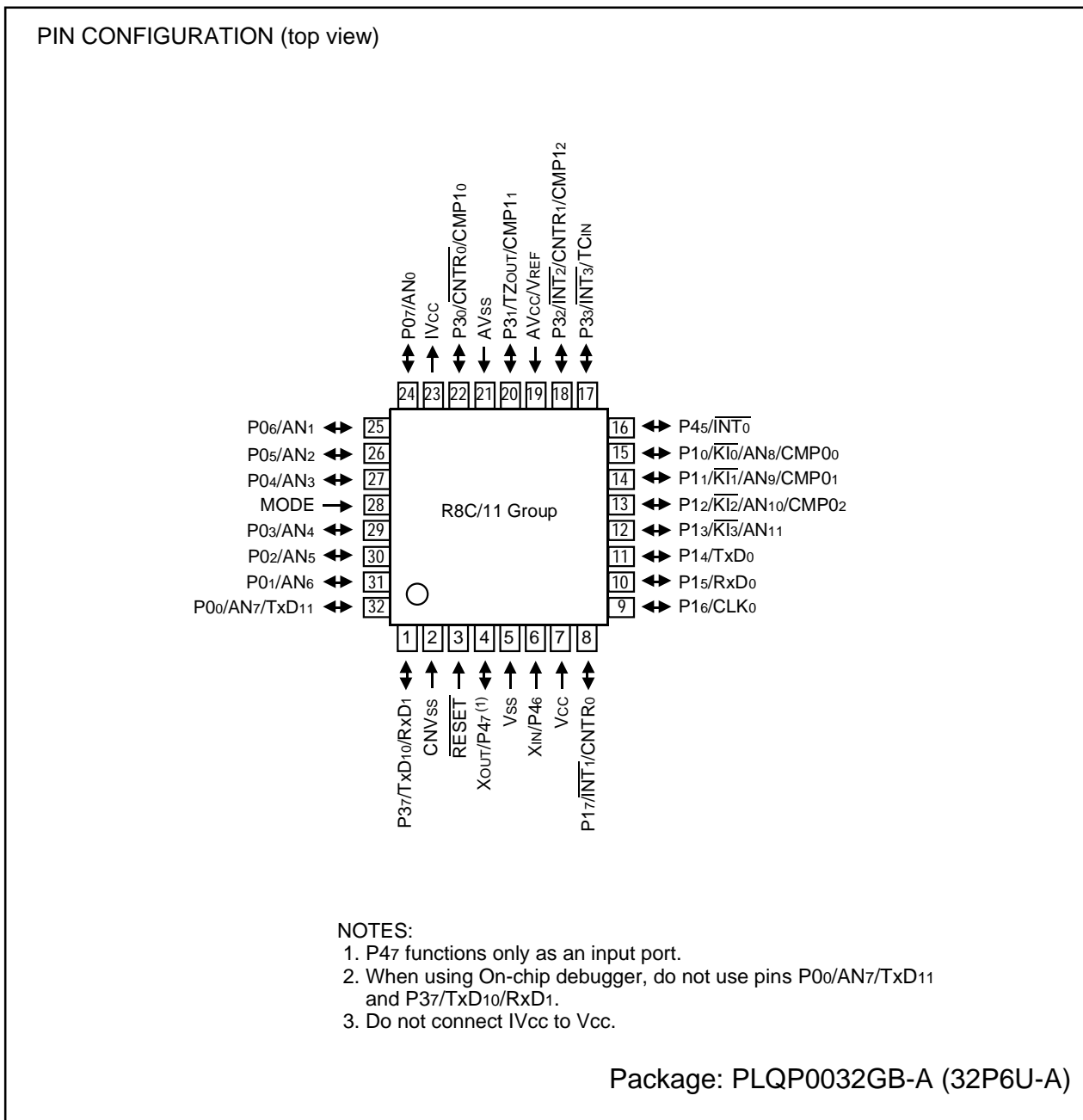

Figure 1.3 Pin Assignments (Top View)



## 1.6 Pin Description

Table 1.3 shows the pin description

**Table 1.3 Pin description**

Signal name	Pin name	I/O type	Function
Power supply input	Vcc, Vss	I	Apply 2.7 V to 5.5 V to the Vcc pin. Apply 0 V to the Vss pin.
IVcc	IVcc	O	This pin is to stabilize internal power supply. Connect this pin to Vss via a capacitor (0.1 $\mu$ F). Do not connect to Vcc.
Analog power supply input	AVcc, AVss	I	Power supply input pins for A/D converter. Connect the AVcc pin to Vcc. Connect the AVss pin to Vss. Connect a capacitor between pins AVcc and AVss.
Reset input	RESET	I	Input "L" on this pin resets the MCU.
CNVss	CNVss	I	Connect this pin to Vss via a resistor. <sup>(1)</sup>
MODE	MODE	I	Connect this pin to Vcc via a resistor.
Main clock input	XIN	I	These pins are provided for the main clock generating circuit I/O. Connect a ceramic resonator or a crystal oscillator between the XIN and XOUT pins. To use an externally derived clock, input it to the XIN pin and leave the XOUT pin open.
Main clock output	XOUT	O	
INT interrupt input	INT $\bar{0}$ to INT $\bar{3}$	I	INT interrupt input pins.
Key input interrupt	KI $\bar{0}$ to KI $\bar{3}$	I	Key input interrupt pins.
Timer X	CNTR $\bar{0}$	I/O	Timer X I/O pin
	CNTR $\bar{0}$	O	Timer X output pin
Timer Y	CNTR $\bar{1}$	I/O	Timer Y I/O pin
Timer Z	TZOUT	O	Timer Z output pin
Timer C	TCIN	I	Timer C input pin
	CMP $\bar{0}$ to CMP $\bar{0}$ <sub>2</sub> , CMP $\bar{1}$ <sub>0</sub> to CMP $\bar{1}$ <sub>2</sub>	O	Timer C output pins
Serial interface	CLK $\bar{0}$	I/O	Transfer clock I/O pin.
	RxD $\bar{0}$ , RxD $\bar{1}$	I	Serial data input pins.
	TxD $\bar{0}$ , TxD $\bar{1}$ <sub>0</sub> , TxD $\bar{1}$ <sub>1</sub>	O	Serial data output pins.
Reference voltage input	VREF	I	Reference voltage input pin for A/D converter. Connect the VREF pin to Vcc.
A/D converter	AN $\bar{0}$ to AN $\bar{1}$ <sub>1</sub>	I	Analog input pins for A/D converter
I/O port	P $\bar{0}$ to P $\bar{7}$ , P $\bar{1}$ <sub>0</sub> to P $\bar{1}$ <sub>7</sub> , P $\bar{3}$ <sub>0</sub> to P $\bar{3}$ <sub>3</sub> , P $\bar{3}$ <sub>7</sub> , P $\bar{4}$ <sub>5</sub>	I/O	These are 8-bit CMOS I/O ports. Each port has an I/O select direction register, allowing each pin in that port to be directed for input or output individually. Any port set to input can select whether to use a pull-up resistor or not by program. P $\bar{1}$ <sub>0</sub> to P $\bar{1}$ <sub>7</sub> also function as LED drive ports.
Input port	P $\bar{4}$ <sub>6</sub> , P $\bar{4}$ <sub>7</sub>	I	Port for input-only

NOTES :

1. Refer to "19.8 Noise" for the connecting reference resistor value.

## 2. Central Processing Unit (CPU)

Figure 2.1 shows the CPU registers. The CPU has 13 registers. Of these, R0, R1, R2, R3, A0, A1 and FB comprise a register bank. Two sets of register banks are provided.

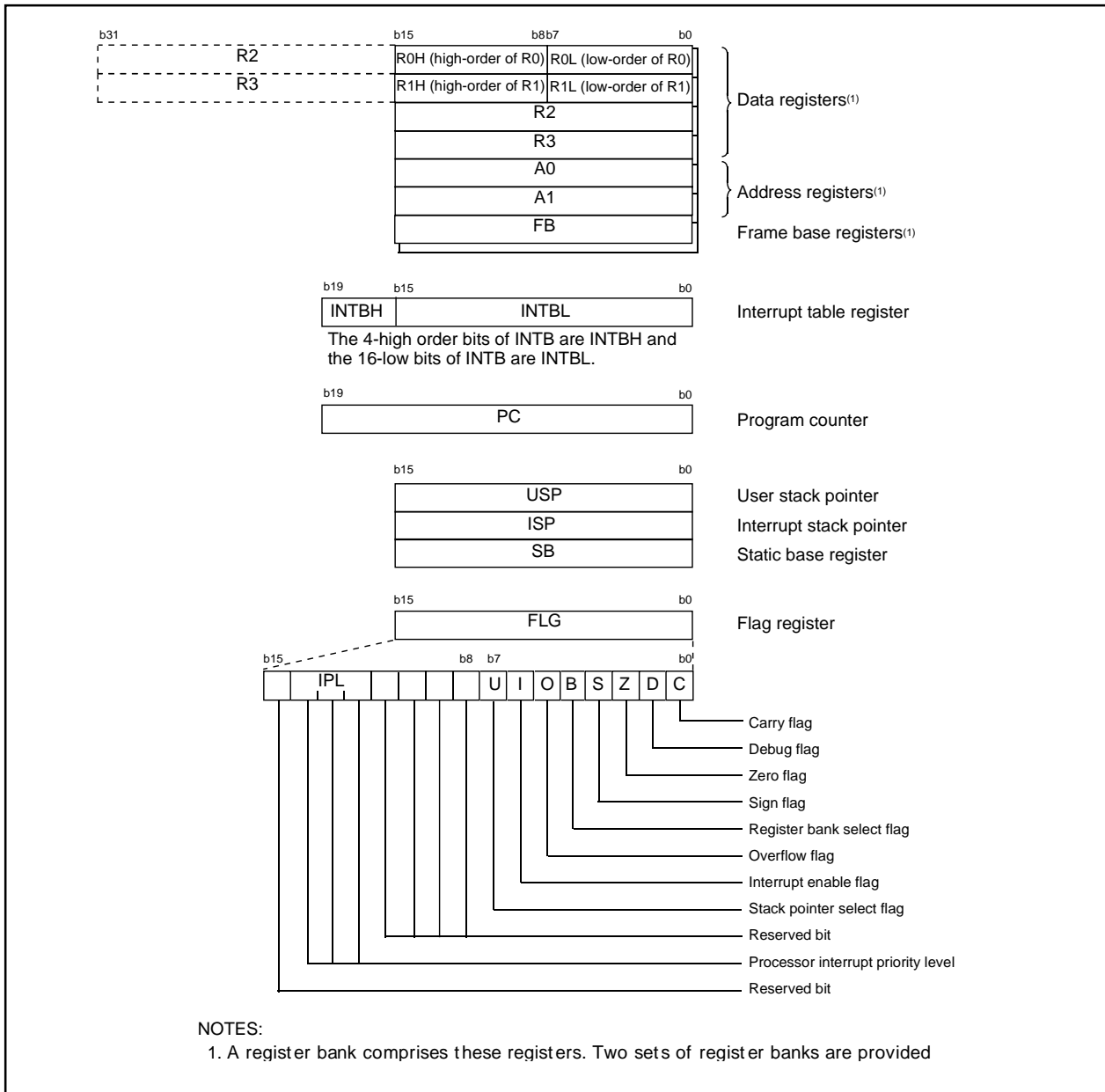

Figure 2.1 CPU Register

### 2.1 Data Registers (R0, R1, R2 and R3)

R0 is a 16-bit register for transfer, arithmetic and logic operations. The same applies to R1 to R3. The R0 can be split into high-order bit (R0H) and low-order bit (R0L) to be used separately as 8-bit data registers. The same applies to R1H and R1L as R0H and R0L. R2 can be combined with R0 to be used as a 32-bit data register (R2R0). The same applies to R3R1 as R2R0.

## 2.2 Address Registers (A0 and A1)

A0 is a 16-bit register for address register indirect addressing and address register relative addressing. They also are used for transfer, arithmetic and logic operations. The same applies to A1 as A0. A0 can be combined with A1 to be used as a 32-bit address register (A1A0).

## 2.3 Frame Base Register (FB)

FB is a 16-bit register for FB relative addressing.

## 2.4 Interrupt Table Register (INTB)

INTB is a 20-bit register indicates the start address of an interrupt vector table.

## 2.5 Program Counter (PC)

PC, 20 bits wide, indicates the address of an instruction to be executed.

## 2.6 User Stack Pointer (USP) and Interrupt Stack Pointer (ISP)

The stack pointer (SP), USP and ISP, are 16 bits wide each.

The U flag of FLG is used to switch between USP and ISP.

## 2.7 Static Base Register (SB)

SB is a 16-bit register for SB relative addressing.

## 2.8 Flag Register (FLG)

FLG is a 11-bit register indicating the CPU state.

### 2.8.1 Carry Flag (C)

The C flag retains a carry, borrow, or shift-out bit that has occurred in the arithmetic logic unit.

### 2.8.2 Debug Flag (D)

The D flag is for debug only. Set to "0".

### 2.8.3 Zero Flag (Z)

The Z flag is set to "1" when an arithmetic operation resulted in 0; otherwise, "0".

### 2.8.4 Sign Flag (S)

The S flag is set to "1" when an arithmetic operation resulted in a negative value; otherwise, "0".

### 2.8.5 Register Bank Select Flag (B)

The register bank 0 is selected when the B flag is "0". The register bank 1 is selected when this flag is set to "1".

### 2.8.6 Overflow Flag (O)

The O flag is set to "1" when the operation resulted in an overflow; otherwise, "0".

### 2.8.7 Interrupt Enable Flag (I)

The I flag enables a maskable interrupt.

An interrupt is disabled when the I flag is set to "0", and are enabled when the I flag is set to "1". The I flag is set to "0" when an interrupt request is acknowledged.

### 2.8.8 Stack Pointer Select Flag (U)

ISP is selected when the U flag is set to "0", USP is selected when the U flag is set to "1".

The U flag is set to "0" when a hardware interrupt request is acknowledged or the INT instruction of software interrupt numbers 0 to 31 is executed.

### 2.8.9 Processor Interrupt Priority Level (IPL)

IPL, 3 bits wide, assigns processor interrupt priority levels from level 0 to level 7.

If a requested interrupt has greater priority than IPL, the interrupt is enabled.

### 2.8.10 Reserved Bit

When write to this bit, set to "0". When read, its content is indeterminate.

### 3. Memory

Figure 3.1 is a memory map of this MCU. This MCU provides 1-Mbyte address space from addresses 00000<sub>16</sub> to FFFFF<sub>16</sub>.

The internal ROM is allocated lower addresses beginning with address 0C000<sub>16</sub>. For example, a 16-Kbyte internal ROM is allocated addresses from 0C000<sub>16</sub> to 0FFFF<sub>16</sub>.

The fixed interrupt vector table is allocated addresses 0FFDC<sub>16</sub> to 0FFFF<sub>16</sub>. They store the starting address of each interrupt routine.

The internal RAM is allocated higher addresses beginning with address 00400<sub>16</sub>. For example, a 1-Kbyte internal RAM is allocated addresses 00400<sub>16</sub> to 007FF<sub>16</sub>. The internal RAM is used not only for storing data, but for calling subroutines and stacks when interrupt request is acknowledged.

Special function registers (SFR) are allocated addresses 00000<sub>16</sub> to 002FF<sub>16</sub>. The peripheral function control registers are located them. All addresses, which have nothing allocated within the SFR, are reserved area and cannot be accessed by users.

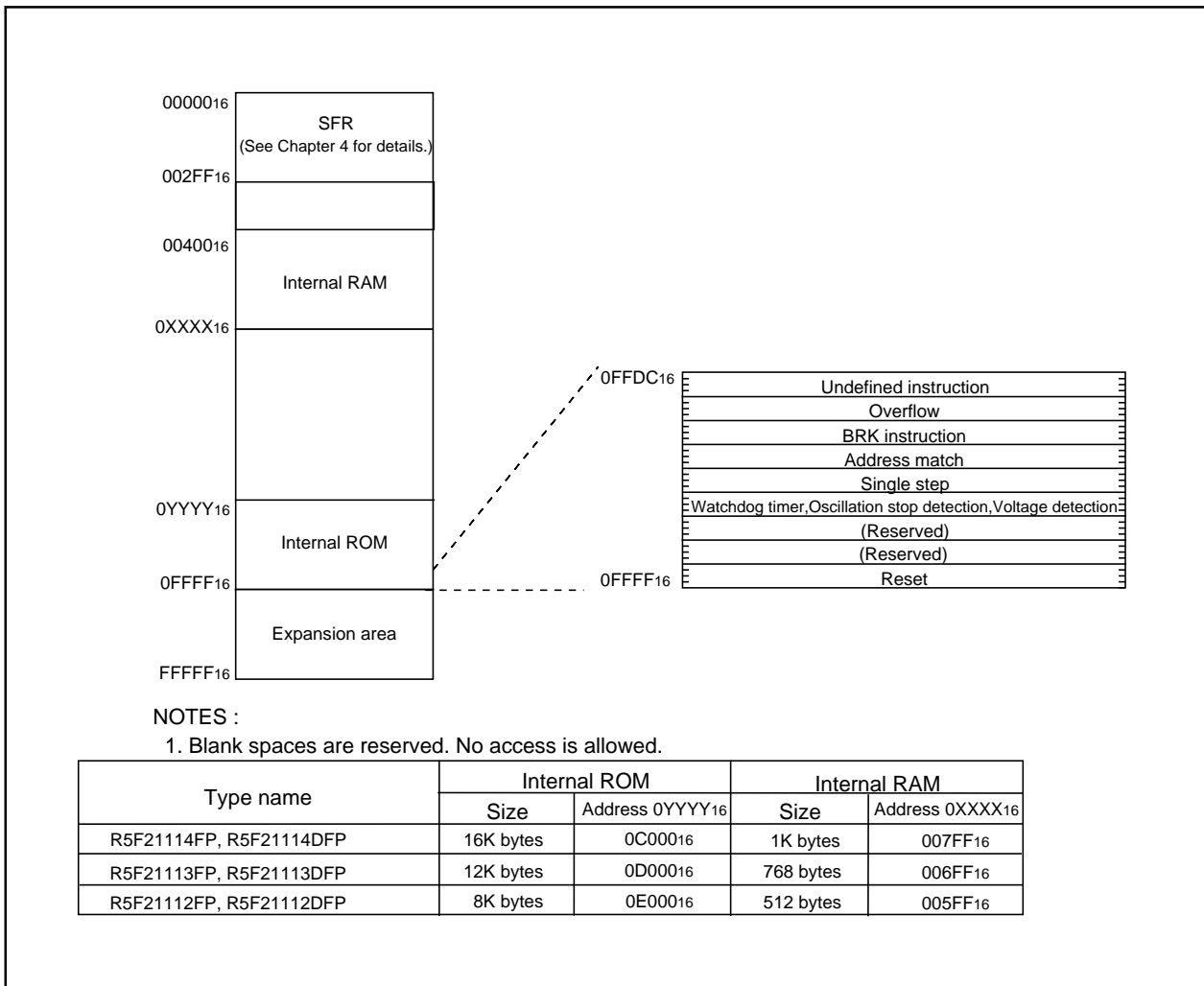

Figure 3.1 Memory Map

## 4. Special Function Register (SFR)

SFR(Special Function Register) is the control register of peripheral functions. Tables 4.1 to 4.4 list the SFR information

**Table 4.1 SFR Information(1)(1)**

Address	Register	Symbol	After reset
0000 <sub>16</sub>			
0001 <sub>16</sub>			
0002 <sub>16</sub>			
0003 <sub>16</sub>			
0004 <sub>16</sub>	Processor mode register 0	PM0	0016
0005 <sub>16</sub>	Processor mode register 1	PM1	0016
0006 <sub>16</sub>	System clock control register 0	CM0	011010002
0007 <sub>16</sub>	System clock control register 1	CM1	001000002
0008 <sub>16</sub>	High-speed on-chip oscillator control register 0	HR0	0016
0009 <sub>16</sub>	Address match interrupt enable register	AIER	XXXXXX002
000A <sub>16</sub>	Protect register	PRCR	00XXX0002
000B <sub>16</sub>	High-speed on-chip oscillator control register 1	HR1	4016
000C <sub>16</sub>	Oscillation stop detection register	OCD	000001002
000D <sub>16</sub>	Watchdog timer reset register	WDTR	XX16
000E <sub>16</sub>	Watchdog timer start register	WDTS	XX16
000F <sub>16</sub>	Watchdog timer control register	WDC	000111112
0010 <sub>16</sub>	Address match interrupt register 0	RMAD0	0016
0011 <sub>16</sub>			0016
0012 <sub>16</sub>			X016
0013 <sub>16</sub>			
0014 <sub>16</sub>	Address match interrupt register 1	RMAD1	0016
0015 <sub>16</sub>			0016
0016 <sub>16</sub>			X016
0017 <sub>16</sub>			
0018 <sub>16</sub>			
0019 <sub>16</sub>	Voltage detection register 1 <sup>(2)</sup>	VCR1	000010002
001A <sub>16</sub>	Voltage detection register 2 <sup>(2)</sup>	VCR2	0016 <sup>(3)</sup> 10000002 <sup>(4)</sup>
001B <sub>16</sub>			
001C <sub>16</sub>			
001D <sub>16</sub>			
001E <sub>16</sub>	INT0 input filter select register	INT0F	XXXXX0002
001F <sub>16</sub>	Voltage detection interrupt register <sup>(2)</sup>	D4INT	0016 <sup>(3)</sup> 010000012 <sup>(4)</sup>
0020 <sub>16</sub>			
0021 <sub>16</sub>			
0022 <sub>16</sub>			
0023 <sub>16</sub>			
0024 <sub>16</sub>			
0025 <sub>16</sub>			
0026 <sub>16</sub>			
0027 <sub>16</sub>			
0028 <sub>16</sub>			
0029 <sub>16</sub>			
002A <sub>16</sub>			
002B <sub>16</sub>			
002C <sub>16</sub>			
002D <sub>16</sub>			
002E <sub>16</sub>			
002F <sub>16</sub>			
0030 <sub>16</sub>			
0031 <sub>16</sub>			
0032 <sub>16</sub>			
0033 <sub>16</sub>			
0034 <sub>16</sub>			
0035 <sub>16</sub>			
0036 <sub>16</sub>			
0037 <sub>16</sub>			
0038 <sub>16</sub>			
0039 <sub>16</sub>			
003A <sub>16</sub>			
003B <sub>16</sub>			
003C <sub>16</sub>			
003D <sub>16</sub>			
003E <sub>16</sub>			
003F <sub>16</sub>			

X : Undefined

NOTES:

- Blank spaces are reserved. No access is allowed.
- Software reset or the watchdog timer reset does not affect this register.
- Owing to Reset input.
- In the case of RESET pin = H retaining.

Table 4.2 SFR Information(2)<sup>(1)</sup>

Address	Register	Symbol	After reset
0040 <sub>16</sub>			
0041 <sub>16</sub>			
0042 <sub>16</sub>			
0043 <sub>16</sub>			
0044 <sub>16</sub>			
0045 <sub>16</sub>			
0046 <sub>16</sub>			
0047 <sub>16</sub>			
0048 <sub>16</sub>			
0049 <sub>16</sub>			
004A <sub>16</sub>			
004B <sub>16</sub>			
004C <sub>16</sub>			
004D <sub>16</sub>	Key input interrupt control register	KUPIC	XXXXX0002
004E <sub>16</sub>	AD conversion interrupt control register	ADIC	XXXXX0002
004F <sub>16</sub>			
0050 <sub>16</sub>	Compare 1 interrupt control register	CMP1IC	XXXXX0002
0051 <sub>16</sub>	UART0 transmit interrupt control register	S0TIC	XXXXX0002
0052 <sub>16</sub>	UART0 receive interrupt control register	S0RIC	XXXXX0002
0053 <sub>16</sub>	UART1 transmit interrupt control register	S1TIC	XXXXX0002
0054 <sub>16</sub>	UART1 receive interrupt control register	S1RIC	XXXXX0002
0055 <sub>16</sub>	INT2 interrupt control register	INT2IC	XXXXX0002
0056 <sub>16</sub>	Timer X interrupt control register	TXIC	XXXXX0002
0057 <sub>16</sub>	Timer Y interrupt control register	TYIC	XXXXX0002
0058 <sub>16</sub>	Timer Z interrupt control register	TZIC	XXXXX0002
0059 <sub>16</sub>	INT1 interrupt control register	INT1IC	XXXXX0002
005A <sub>16</sub>	INT3 interrupt control register	INT3IC	XXXXX0002
005B <sub>16</sub>	Timer C interrupt control register	TCIC	XXXXX0002
005C <sub>16</sub>	Compare 0 interrupt control register	CMP0IC	XXXXX0002
005D <sub>16</sub>	INT0 interrupt control register	INT0IC	XX00X0002
005E <sub>16</sub>			
005F <sub>16</sub>			
0060 <sub>16</sub>			
0061 <sub>16</sub>			
0062 <sub>16</sub>			
0063 <sub>16</sub>			
0064 <sub>16</sub>			
0065 <sub>16</sub>			
0066 <sub>16</sub>			
0067 <sub>16</sub>			
0068 <sub>16</sub>			
0069 <sub>16</sub>			
006A <sub>16</sub>			
006B <sub>16</sub>			
006C <sub>16</sub>			
006D <sub>16</sub>			
006E <sub>16</sub>			
006F <sub>16</sub>			
0070 <sub>16</sub>			
0071 <sub>16</sub>			
0072 <sub>16</sub>			
0073 <sub>16</sub>			
0074 <sub>16</sub>			
0075 <sub>16</sub>			
0076 <sub>16</sub>			
0077 <sub>16</sub>			
0078 <sub>16</sub>			
0079 <sub>16</sub>			
007A <sub>16</sub>			
007B <sub>16</sub>			
007C <sub>16</sub>			
007D <sub>16</sub>			
007E <sub>16</sub>			
007F <sub>16</sub>			

X : Undefined

NOTES:

- Blank spaces are reserved. No access is allowed.

Table 4.3 SFR Information(3)<sup>(1)</sup>

Address	Register	Symbol	After reset
0080 <sub>16</sub>	Timer Y, Z mode register	TYZMR	0016
0081 <sub>16</sub>	Prescaler Y register	PREY	FF16
0082 <sub>16</sub>	Timer Y secondary register	TYSC	FF16
0083 <sub>16</sub>	Timer Y primary register	TYPR	FF16
0084 <sub>16</sub>	Timer Y, Z waveform output control register	PUM	0016
0085 <sub>16</sub>	Prescaler Z register	PREZ	FF16
0086 <sub>16</sub>	Timer Z secondary register	TZSC	FF16
0087 <sub>16</sub>	Timer Z primary register	TZPR	FF16
0088 <sub>16</sub>			
0089 <sub>16</sub>			
008A <sub>16</sub>	Timer Y, Z output control register	TYZOC	0016
008B <sub>16</sub>	Timer X mode register	TXMR	0016
008C <sub>16</sub>	Prescaler X register	PREX	FF16
008D <sub>16</sub>	Timer X register	TX	FF16
008E <sub>16</sub>	Timer count source set register	TCSS	0016
008F <sub>16</sub>			
0090 <sub>16</sub>	Timer C register	TC	0016
0091 <sub>16</sub>			0016
0092 <sub>16</sub>			
0093 <sub>16</sub>			
0094 <sub>16</sub>			
0095 <sub>16</sub>			
0096 <sub>16</sub>	External input enable register	INTEN	0016
0097 <sub>16</sub>			
0098 <sub>16</sub>	Key input enable register	KIEN	0016
0099 <sub>16</sub>			
009A <sub>16</sub>	Timer C control register 0	TCC0	0016
009B <sub>16</sub>	Timer C control register 1	TCC1	0016
009C <sub>16</sub>	Capture, compare 0 register	TM0	0016
009D <sub>16</sub>			0016 <sup>(2)</sup>
009E <sub>16</sub>	Compare 1 register	TM1	FF16
009F <sub>16</sub>			FF16
00A0 <sub>16</sub>	UART0 transmit/receive mode register	U0MR	0016
00A1 <sub>16</sub>	UART0 bit rate register	U0BRG	XX16
00A2 <sub>16</sub>	UART0 transmit buffer register	U0TB	XX16
00A3 <sub>16</sub>			XX16
00A4 <sub>16</sub>	UART0 transmit/receive control register 0	U0C0	000010002
00A5 <sub>16</sub>	UART0 transmit/receive control register 1	U0C1	000000102
00A6 <sub>16</sub>	UART0 receive buffer register	U0RB	XX16
00A7 <sub>16</sub>			XX16
00A8 <sub>16</sub>	UART1 transmit/receive mode register	U1MR	0016
00A9 <sub>16</sub>	UART1 bit rate register	U1BRG	XX16
00AA <sub>16</sub>	UART1 transmit buffer register	U1TB	XX16
00AB <sub>16</sub>			XX16
00AC <sub>16</sub>	UART1 transmit/receive control register 0	U1C0	000010002
00AD <sub>16</sub>	UART1 transmit/receive control register 1	U1C1	000000102
00AE <sub>16</sub>	UART1 receive buffer register	U1RB	XX16
00AF <sub>16</sub>			XX16
00B0 <sub>16</sub>	UART transmit/receive control register 2	UCON	0016
00B1 <sub>16</sub>			
00B2 <sub>16</sub>			
00B3 <sub>16</sub>			
00B4 <sub>16</sub>			
00B5 <sub>16</sub>			
00B6 <sub>16</sub>			
00B7 <sub>16</sub>			
00B8 <sub>16</sub>			
00B9 <sub>16</sub>			
00BA <sub>16</sub>			
00BB <sub>16</sub>			
00BC <sub>16</sub>			
00BD <sub>16</sub>			
00BE <sub>16</sub>			
00BF <sub>16</sub>			

X : Undefined

NOTES:

- Blank spaces are reserved. No access is allowed.
- When output compare mode (the TCC13 bit in the TCC1 register = 1) is selected, the value after reset is set to "FFFF16".

Table 4.4 SFR Information(4)<sup>(1)</sup>

Address	Register	Symbol	After reset
00C0 <sub>16</sub>	AD register	AD	XX <sub>16</sub>
00C1 <sub>16</sub>			XX <sub>16</sub>
00C2 <sub>16</sub>			
00C3 <sub>16</sub>			
00C4 <sub>16</sub>			
00C5 <sub>16</sub>			
00C6 <sub>16</sub>			
00C7 <sub>16</sub>			
00C8 <sub>16</sub>			
00C9 <sub>16</sub>			
00CA <sub>16</sub>			
00CB <sub>16</sub>			
00CC <sub>16</sub>			
00CD <sub>16</sub>			
00CE <sub>16</sub>			
00CF <sub>16</sub>			
00D0 <sub>16</sub>			
00D1 <sub>16</sub>			
00D2 <sub>16</sub>			
00D3 <sub>16</sub>			
00D4 <sub>16</sub>	AD control register 2	ADCON2	00 <sub>16</sub>
00D5 <sub>16</sub>			
00D6 <sub>16</sub>	AD control register 0	ADCON0	00000XX <sub>2</sub>
00D7 <sub>16</sub>	AD control register 1	ADCON1	00 <sub>16</sub>
00D8 <sub>16</sub>			
00D9 <sub>16</sub>			
00DA <sub>16</sub>			
00DB <sub>16</sub>			
00DC <sub>16</sub>			
00DD <sub>16</sub>			
00DE <sub>16</sub>			
00DF <sub>16</sub>			
00E0 <sub>16</sub>	Port P0 register	P0	XX <sub>16</sub>
00E1 <sub>16</sub>	Port P1 register	P1	XX <sub>16</sub>
00E2 <sub>16</sub>	Port P0 direction register	PD0	00 <sub>16</sub>
00E3 <sub>16</sub>	Port P1 direction register	PD1	00 <sub>16</sub>
00E4 <sub>16</sub>			
00E5 <sub>16</sub>	Port P3 register	P3	XX <sub>16</sub>
00E6 <sub>16</sub>			
00E7 <sub>16</sub>	Port P3 direction register	PD3	00 <sub>16</sub>
00E8 <sub>16</sub>	Port P4 register	P4	XX <sub>16</sub>
00E9 <sub>16</sub>			
00EA <sub>16</sub>	Port P4 direction register	PD4	00 <sub>16</sub>
00EB <sub>16</sub>			
00EC <sub>16</sub>			
00ED <sub>16</sub>			
00EE <sub>16</sub>			
00EF <sub>16</sub>			
00F0 <sub>16</sub>			
00F1 <sub>16</sub>			
00F2 <sub>16</sub>			
00F3 <sub>16</sub>			
00F4 <sub>16</sub>			
00F5 <sub>16</sub>			
00F6 <sub>16</sub>			
00F7 <sub>16</sub>			
00F8 <sub>16</sub>			
00F9 <sub>16</sub>			
03FA <sub>16</sub>			
00FB <sub>16</sub>			
00FC <sub>16</sub>	Pull-up control register 0	PUR0	00XX0000 <sub>2</sub>
00FD <sub>16</sub>	Pull-up control register 1	PUR1	XXXXXX0X <sub>2</sub>
00FE <sub>16</sub>	Port P1 drive capacity control register	DRR	00 <sub>16</sub>
00FF <sub>16</sub>	Timer C output control register	TCOUT	00 <sub>16</sub>
01B3 <sub>16</sub>	Flash memory control register 4	FMR4	01000000 <sub>2</sub>
01B4 <sub>16</sub>			
01B5 <sub>16</sub>	Flash memory control register 1	FMR1	0100XX0X <sub>2</sub>
01B6 <sub>16</sub>			
01B7 <sub>16</sub>	Flash memory control register 0	FMR0	00000001 <sub>2</sub>

X : Undefined

NOTES:

1. Blank columns, 0100<sub>16</sub> to 01B2<sub>16</sub> and 01B8<sub>16</sub> to 02FF<sub>16</sub> are all reserved. No access is allowed.



## 5. Reset

There are three types of resets: a hardware reset, a software reset, and an watchdog timer reset.

### 5.1 Hardware Reset

There are three kinds of hardware reset: hardware reset 1, hardware reset 2, and power-on reset. After reset, the low-speed on-chip oscillator clock divided by 8 is automatically selected for the CPU.

#### 5.1.1 Hardware Reset 1

A reset is applied using the  $\overline{\text{RESET}}$  pin. When an “L” signal is applied to the  $\overline{\text{RESET}}$  pin while the power supply voltage is within the recommended operating condition, the pins are initialized (see Table 5.1 “Pin Status When  $\overline{\text{RESET}}$  Pin Level is ‘L’”). When the input level at the  $\overline{\text{RESET}}$  pin is released from “L” to “H”, the CPU and SFR are initialized, and the program is executed starting from the address indicated by the reset vector. Figure 5.1 shows the CPU register status after reset and figure 5.2 shows the reset sequence. The internal RAM is not initialized. If the  $\overline{\text{RESET}}$  pin is pulled “L” while writing to the internal RAM, the internal RAM becomes indeterminate.

Figures 5.3 to 5.4 show the reset circuit example using the hardware reset 1. Refer to Chapter 4, “Special Function Register (SFR)” for the status of SFR after reset.

- When the power supply is stable
  - (1) Apply an “L” signal to the  $\overline{\text{RESET}}$  pin.
  - (2) Wait for 500  $\mu\text{s}$  ( $1/f_{\text{RING-S}} \times 20$ ).
  - (3) Apply an “H” signal to the  $\overline{\text{RESET}}$  pin.
  
- Power on
  - (1) Apply an “L” signal to the  $\overline{\text{RESET}}$  pin.
  - (2) Let the power supply voltage increase until it meets the recommended operating condition.
  - (3) Wait  $t_{\text{d(P-R)}}$  or more until the internal power supply stabilizes.
  - (4) Wait for 500  $\mu\text{s}$  ( $1/f_{\text{RING-S}} \times 20$ ).
  - (5) Apply an “H” signal to the  $\overline{\text{RESET}}$  pin.

**Table 5.1 Pin Status When  $\overline{\text{RESET}}$  Pin Level is “L”**

Pin name	Status
P0	Input port
P1	Input port
P30 to P33, P37	Input port
P45 to P47	Input port

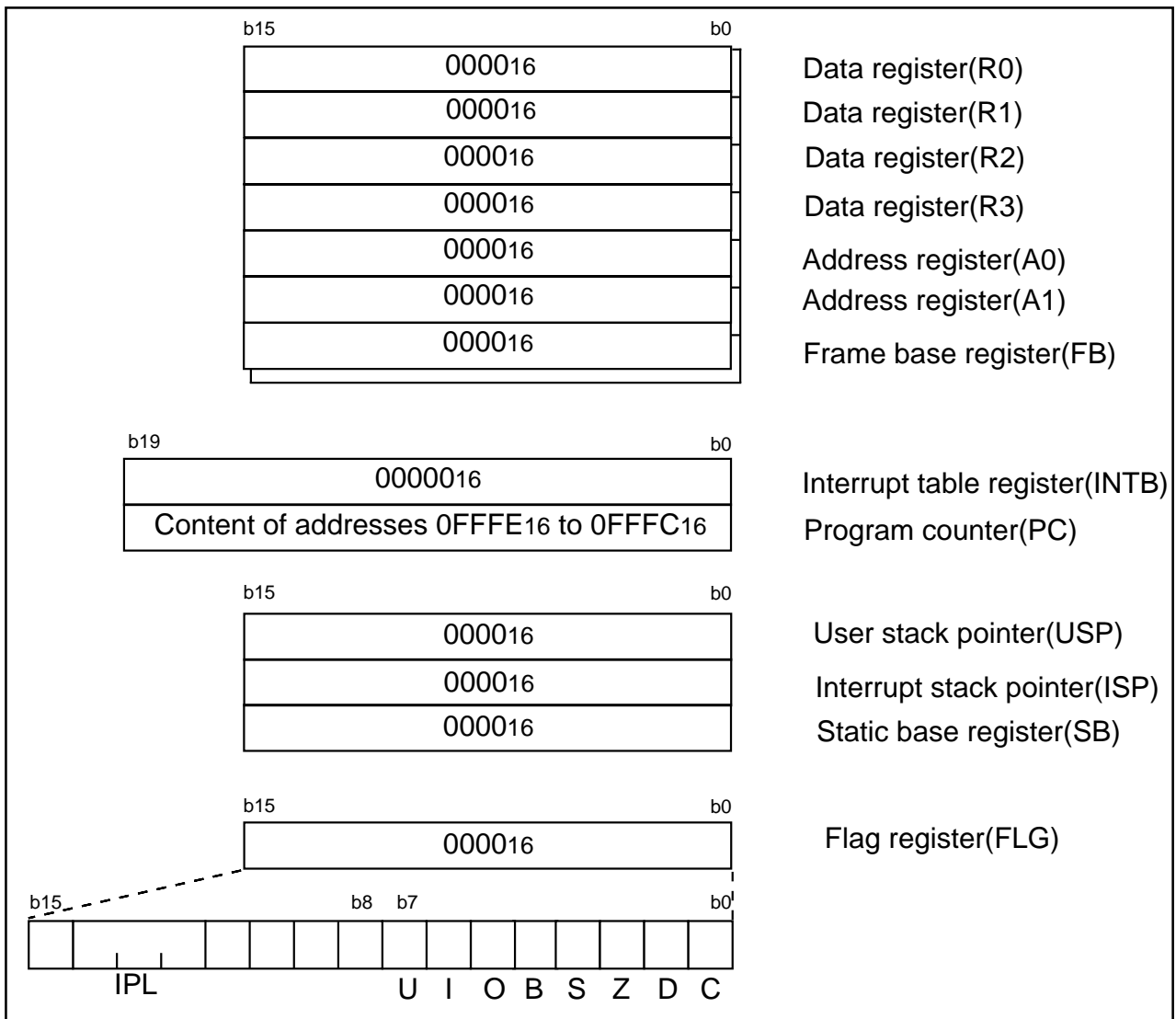

Figure 5.1 CPU Register Status After Reset

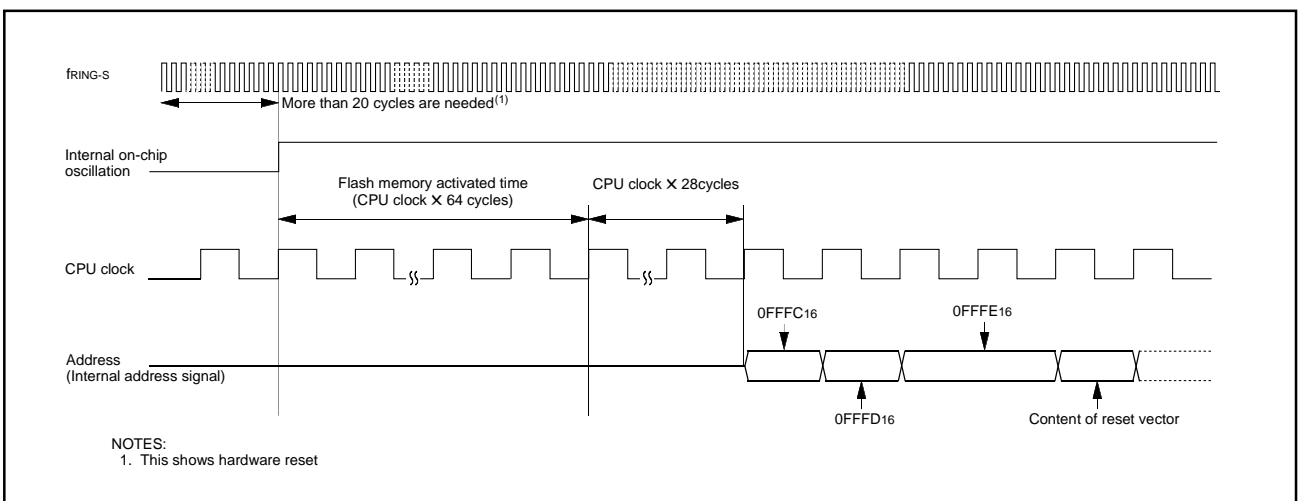

Figure 5.2 Reset Sequence

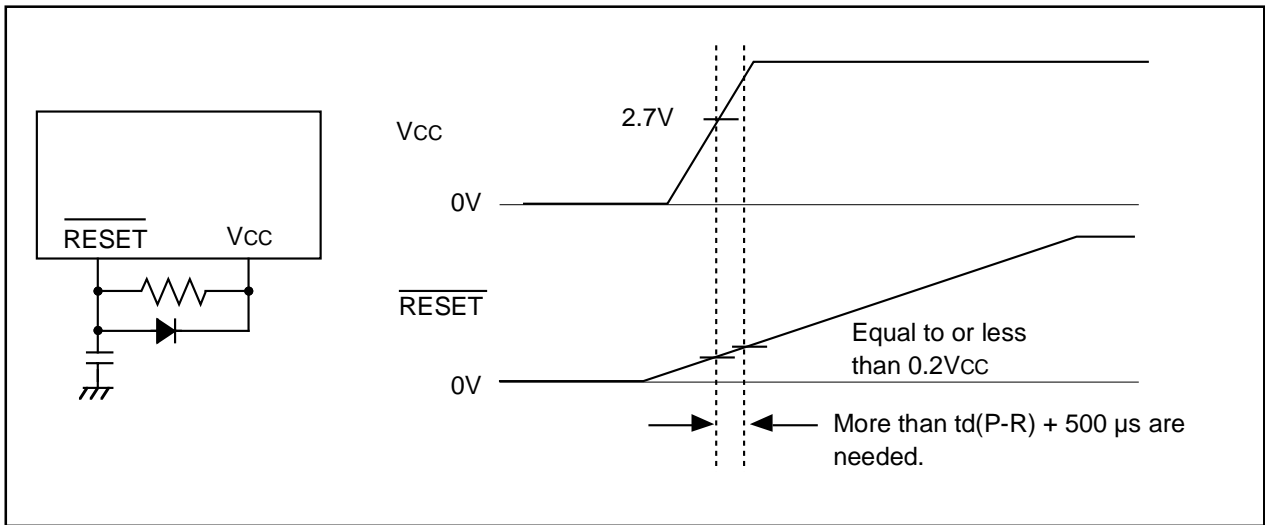

Figure 5.3 Example Reset Circuit Using The Hardware Reset 1

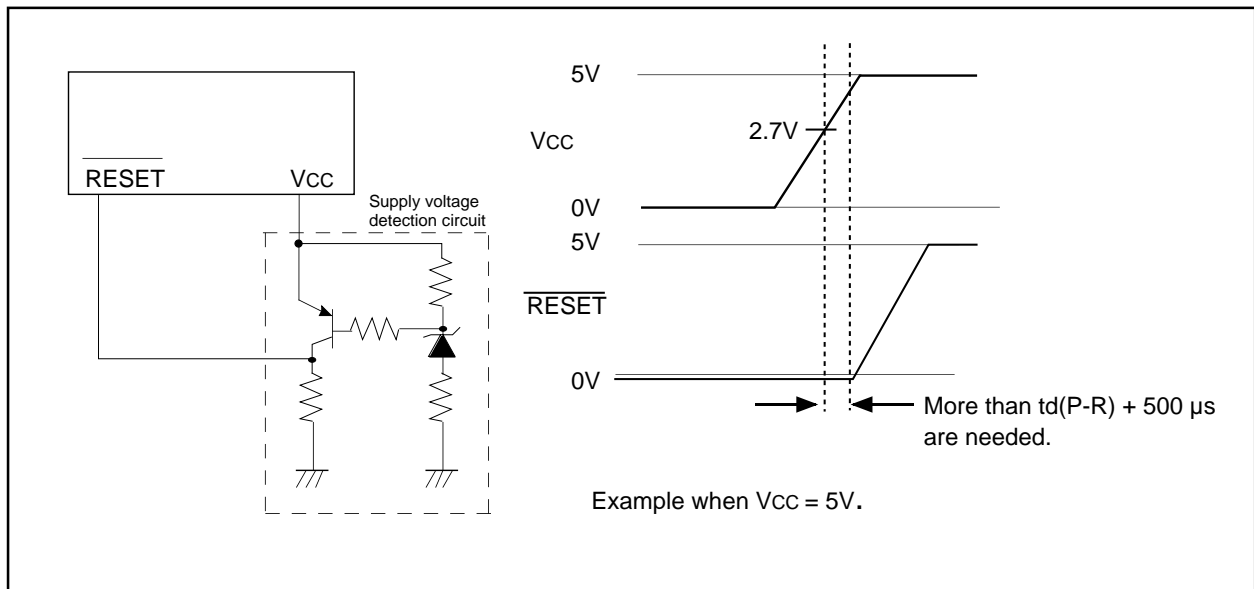

Figure 5.4 Example Reset Circuit Using The Hardware Reset 1 (Voltage Check Circuit)

### 5.1.2 Hardware Reset 2

This is the reset generated by the voltage detection circuit which is built-in to the microcomputer. The voltage detection circuit monitors the input voltage at Vcc input pin. The microcomputer is reset when the voltage at the VCC input pin drops below Vdet if all of the following conditions hold true.

- The VC27 bit in the VCR2 register is set to "1" (voltage detection circuit enabled)
- The D40 bit in the D4INT register is set to "1" (voltage detection interrupt enabled)
- The D46 bit in the D4INT register is set to "1" (hardware reset 2 when going through Vdet)

When using a digital filter (D41 bit in the D4INT register is set to "1"), set the CM14 bit in the CM1 register to "0"(low-speed on-chip oscillator oscillates).

Conversely, when the input voltage at the Vcc pin rises to Vdet or more, the pins, CPU, and SFR are initialized and counting the low-speed on-chip oscillator starts. When counting the low-speed on-chip oscillator clock 32 times, the internal reset is exited and the program is executed beginning with the address indicated by the reset vector. The initialized pins and registers and the status thereof are the same as in hardware reset 1. Refer to Section 5.4 "Voltage Detection Circuit."

### 5.1.3 Power-on Reset Function

The power-on reset is the function which can reset the microcomputer without the external reset circuit. The  $\overline{\text{RESET}}$  pin should be connected to the VCC pin via about 5 k $\Omega$  pull-up resistance using the power-on reset function, the function turns to active and the microcomputer has its pins, CPU and SFR initialized. When a capacitor is connected to the  $\overline{\text{RESET}}$  pin, always keep the voltage to the  $\overline{\text{RESET}}$  pin 0.8 VCC or more.

When the input voltage at the VCC pin reaches to the Vdet level, count operation of the low-speed on-chip oscillator clock starts. When the operation counts the low-speed on-chip oscillator clock for 32 times, the internal reset is released. Then the program is executed starting from the address indicated by the reset vector. The initialized pins and registers and the status thereof are the same as in hardware reset 1 excluding the following bits.

- The D40 bit in the D4INT register turns to "1" automatically (voltage detection interrupt enabled)
- The D46 bit in the D4INT register turns to "1" automatically (hardware reset 2 when going through Vdet)

Additionally, the hardware reset 2 turns to active after the power-on reset. This is because the VC27 bit in the VCR2 register is set to "1" (voltage detection circuit enabled) after the power-on reset same as the hardware reset 1, so that hardware reset 2 active conditions are all satisfied including above D40 and D46 bit conditions.

Figure 5.5 shows the power-on reset circuit. Figure 5.6 shows the power-on reset operation.

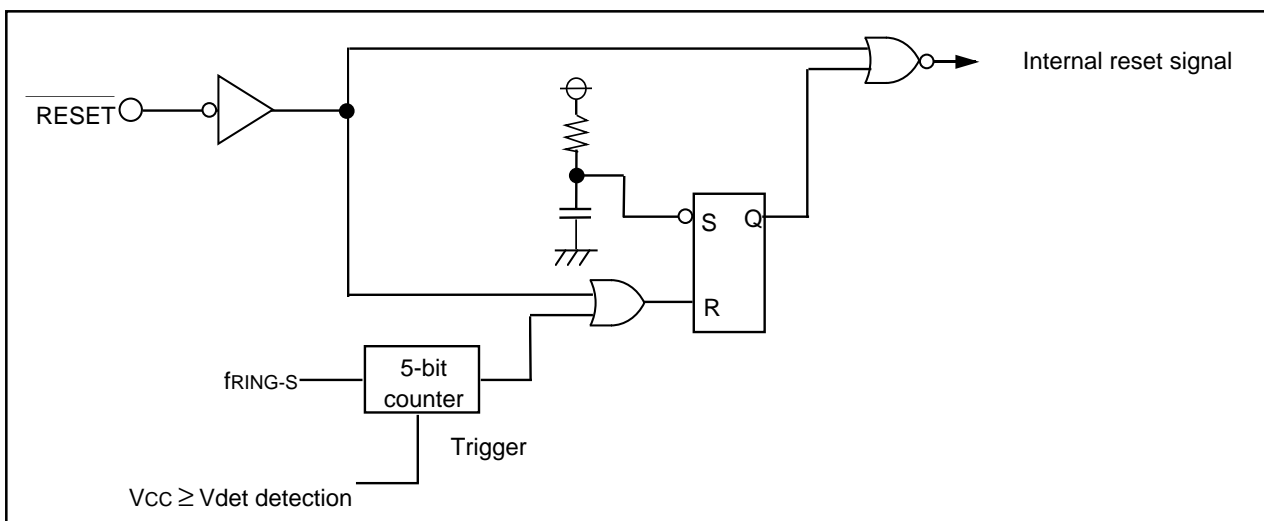

Figure 5.5 Power-on Reset Circuit

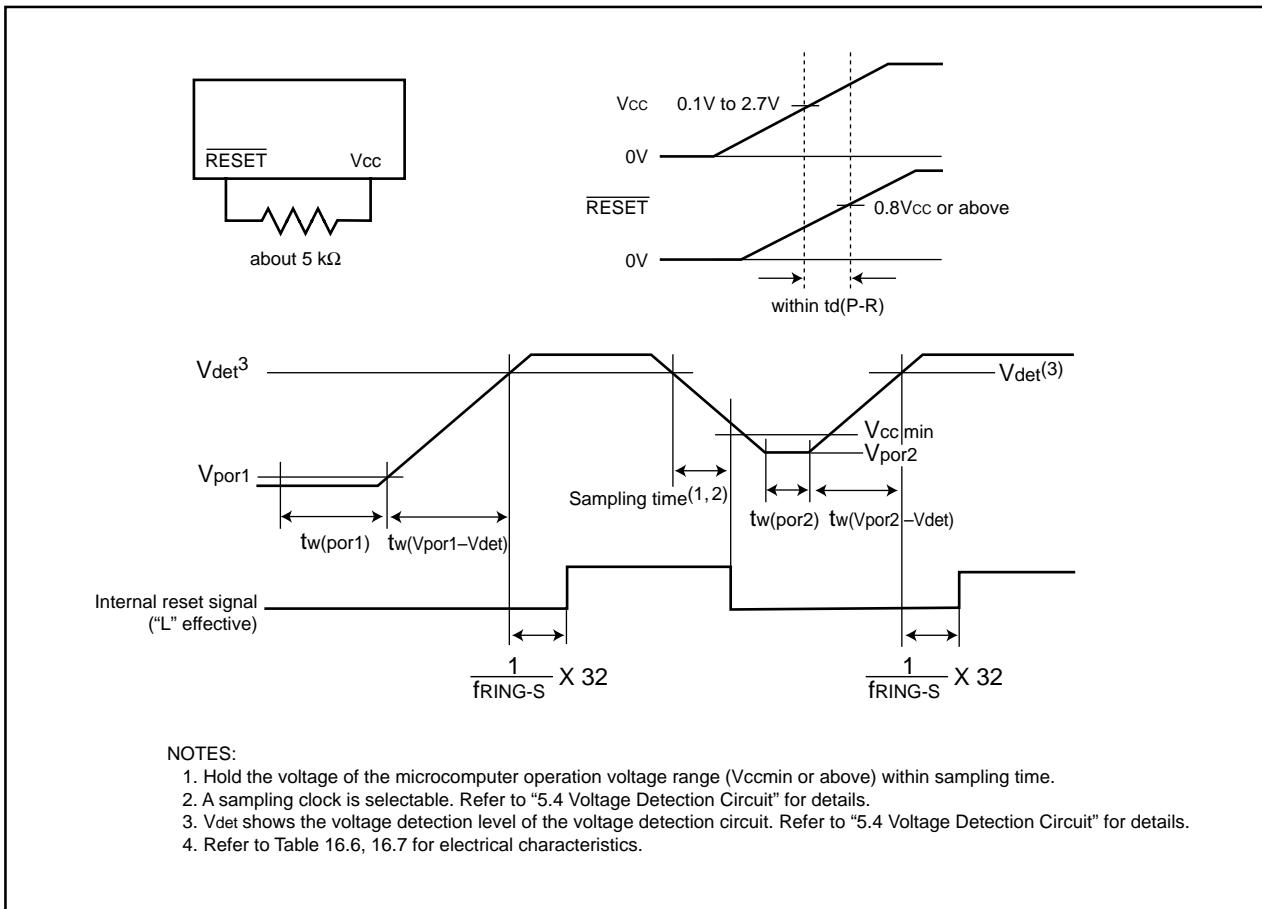

Figure 5.6 Power-on Reset Operation

## 5.2 Software Reset

When the PM03 bit in the PM0 register is set to “1” (microcomputer reset), the microcomputer has its pins, CPU, and SFR initialized. Then the program is executed starting from the address indicated by the reset vector. After reset, the low-speed on-chip oscillator clock divided by 8 is automatically selected for the CPU. Some SFRs are not initialized by the software reset. Refer to Chapter 4, “SFR.”

## 5.3 Watchdog Timer Reset

Where the PM12 bit in the PM1 register is “1” (reset when watchdog timer underflows), the microcomputer initializes its pins, CPU and SFR if the watchdog timer underflows. Then the program is executed starting from the address indicated by the reset vector. After reset, the low-speed on-chip oscillator clock divided by 8 is automatically selected for the CPU. Some SFRs are not initialized by the watchdog timer reset. Refer to Chapter 4, “SFR.”

### 5.4 Voltage Detection Circuit

The voltage detection circuit monitors the input voltage at the VCC pin with respect to Vdet. The user program can check for voltage detection using the VC13 bit or set up the voltage detection interrupt register to generate a hardware reset 2 or voltage detection interrupt.

Figure 5.7 shows the voltage detection circuit. Figure 5.8 shows VCR1 and VCR2 registers. Figure 5.9 shows the D4INT register. Figure 5.10 shows an operation example of the voltage detection circuit. Figure 5.11 to 5.12 show the operation example of the voltage detection circuit to get out of stop mode.

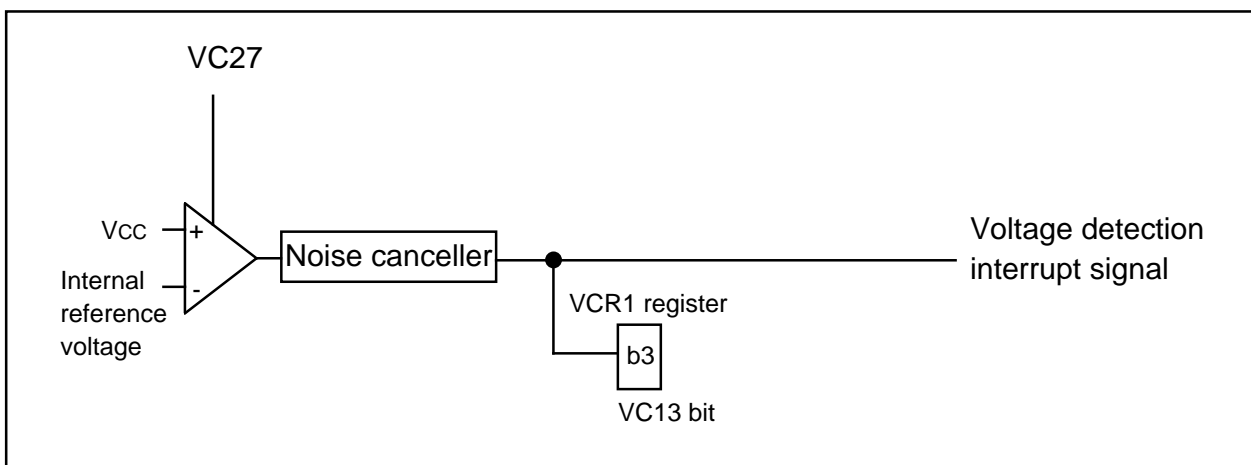

Figure 5.7 Voltage Detection Circuit Block



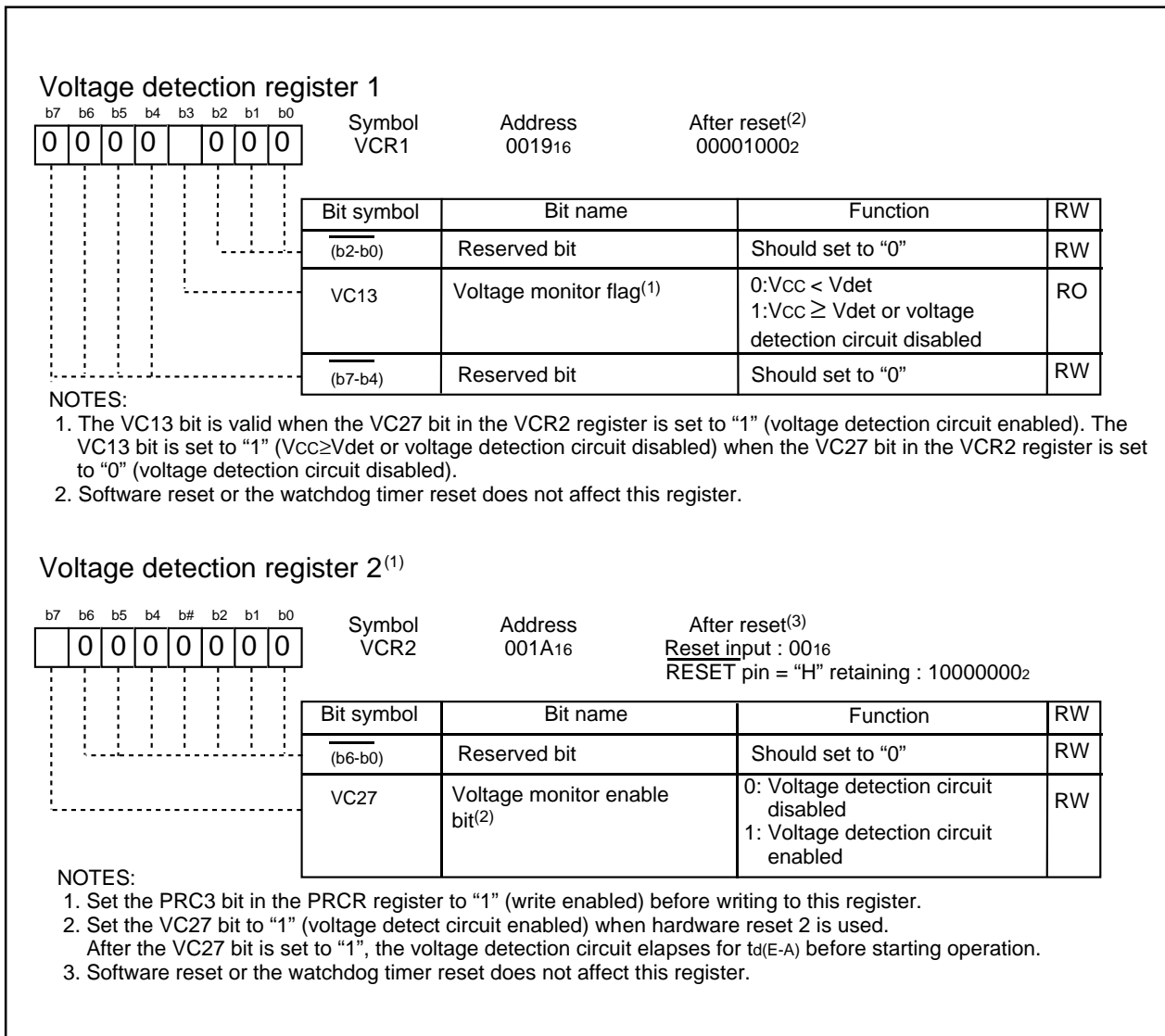

Figure 5.8 VCR1 Register and VCR2 Register

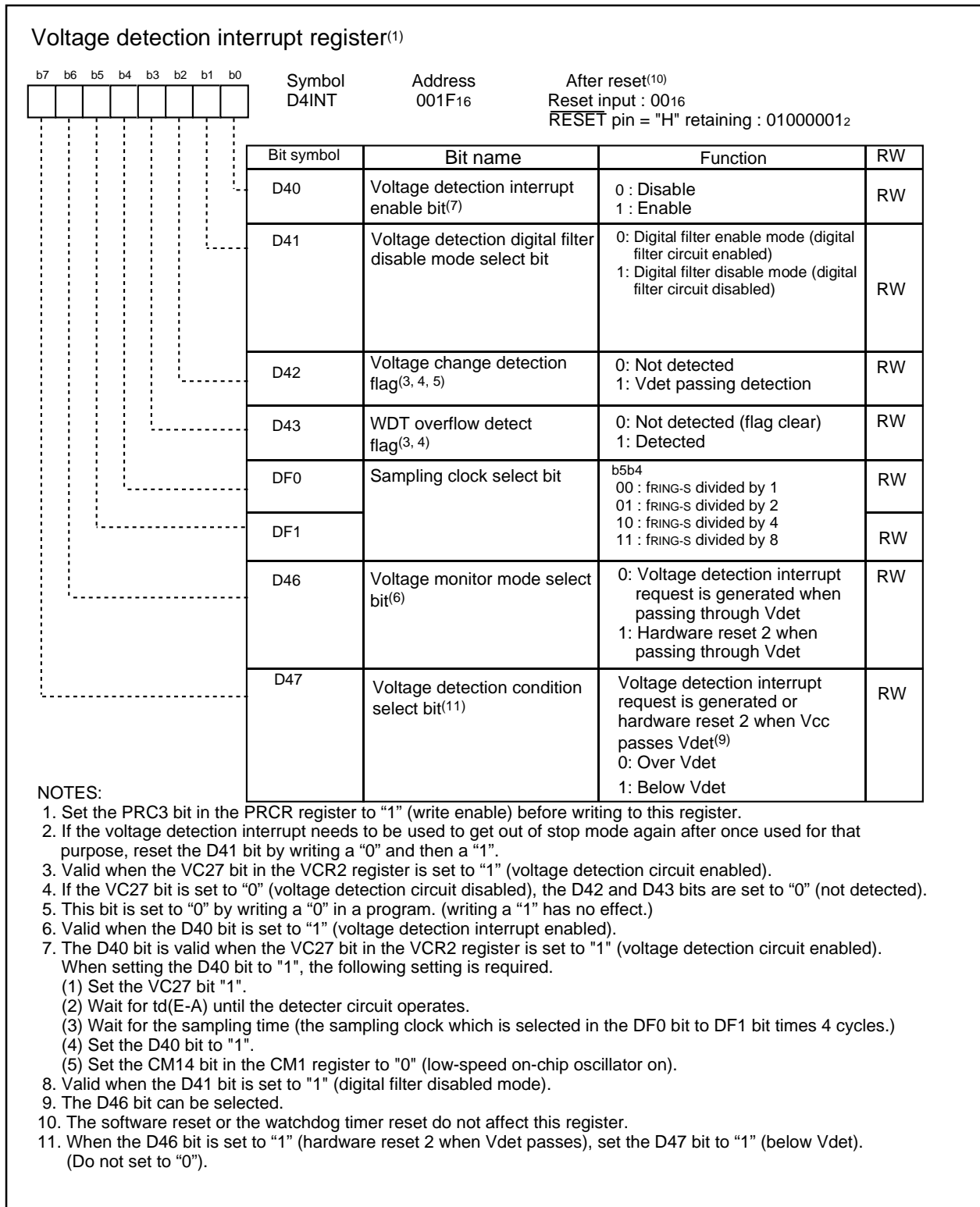

Figure 5.9 D4INT Register

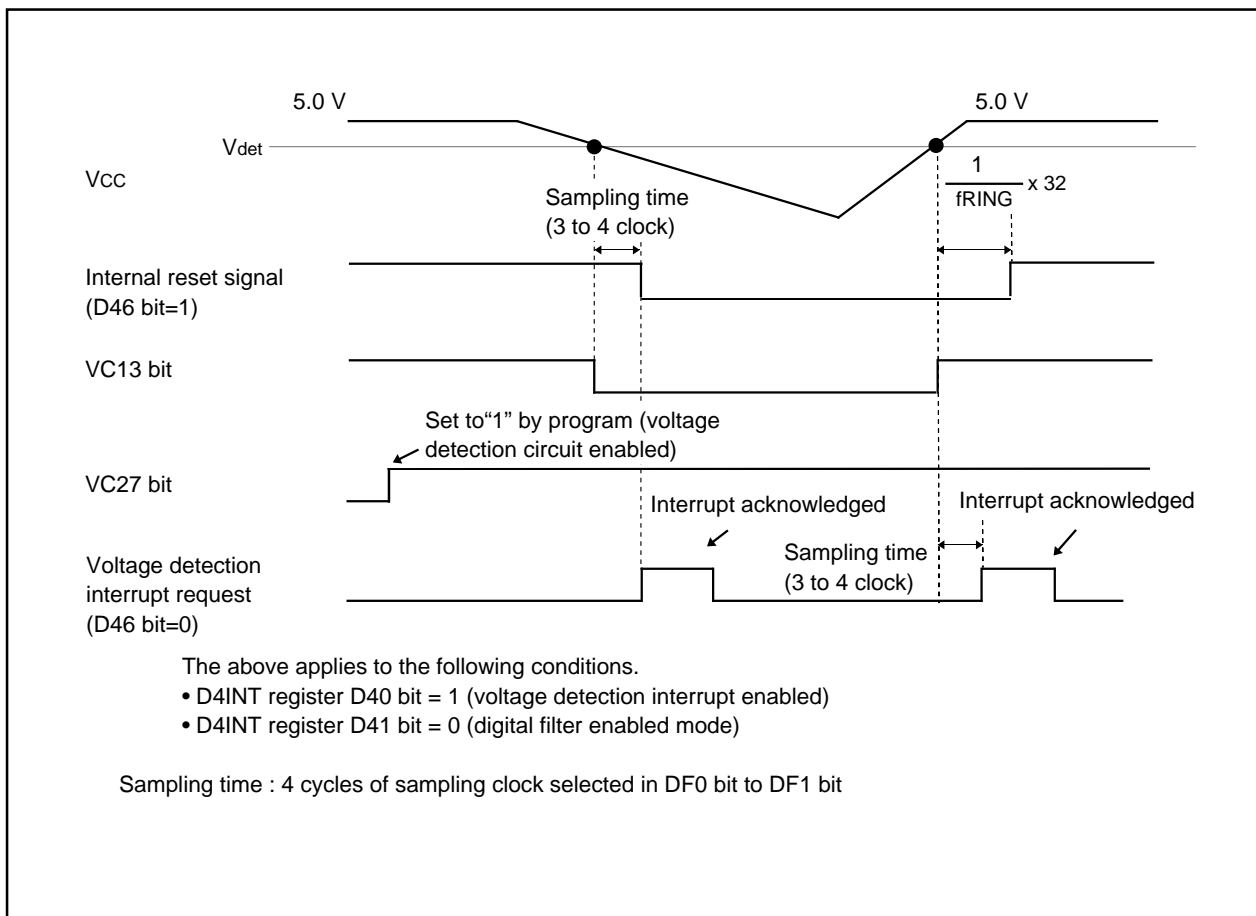
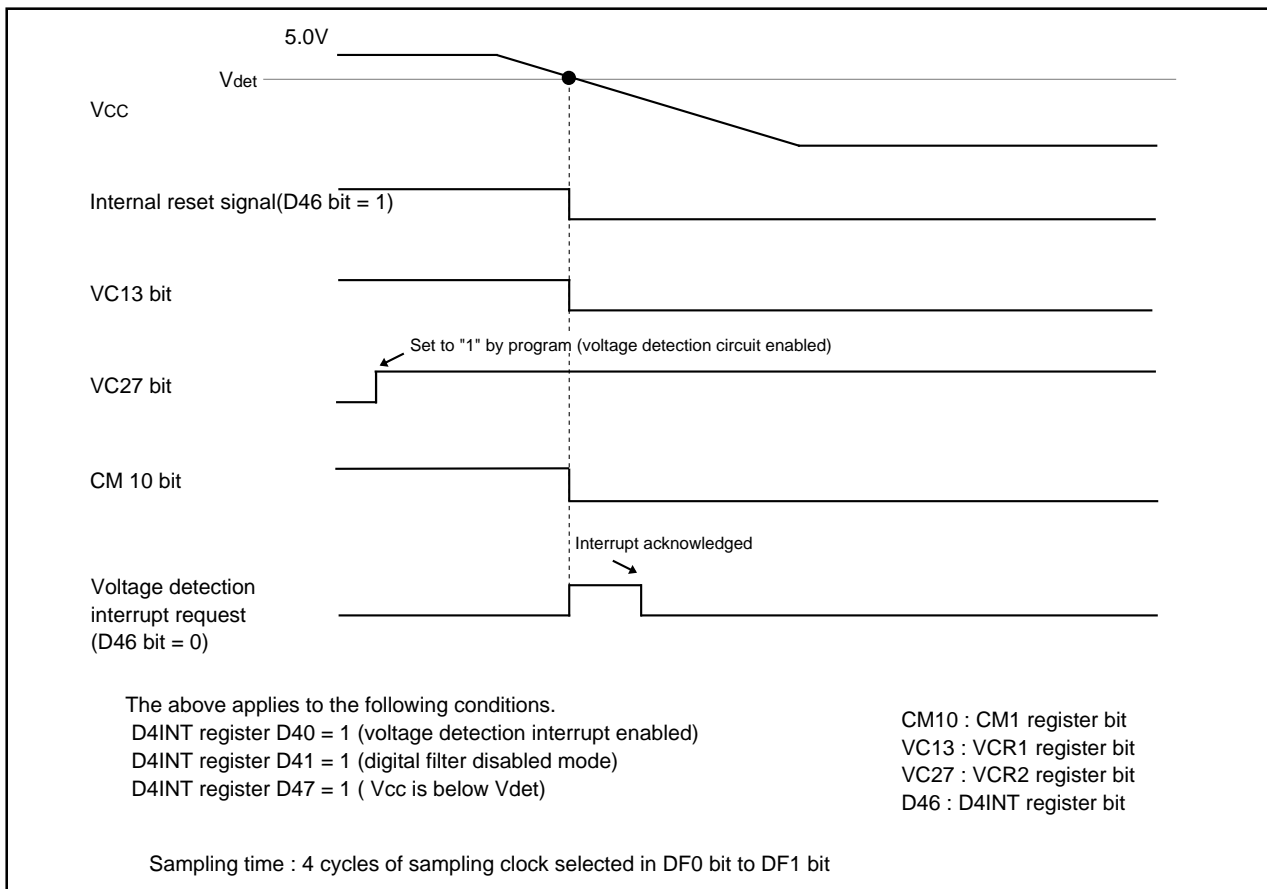
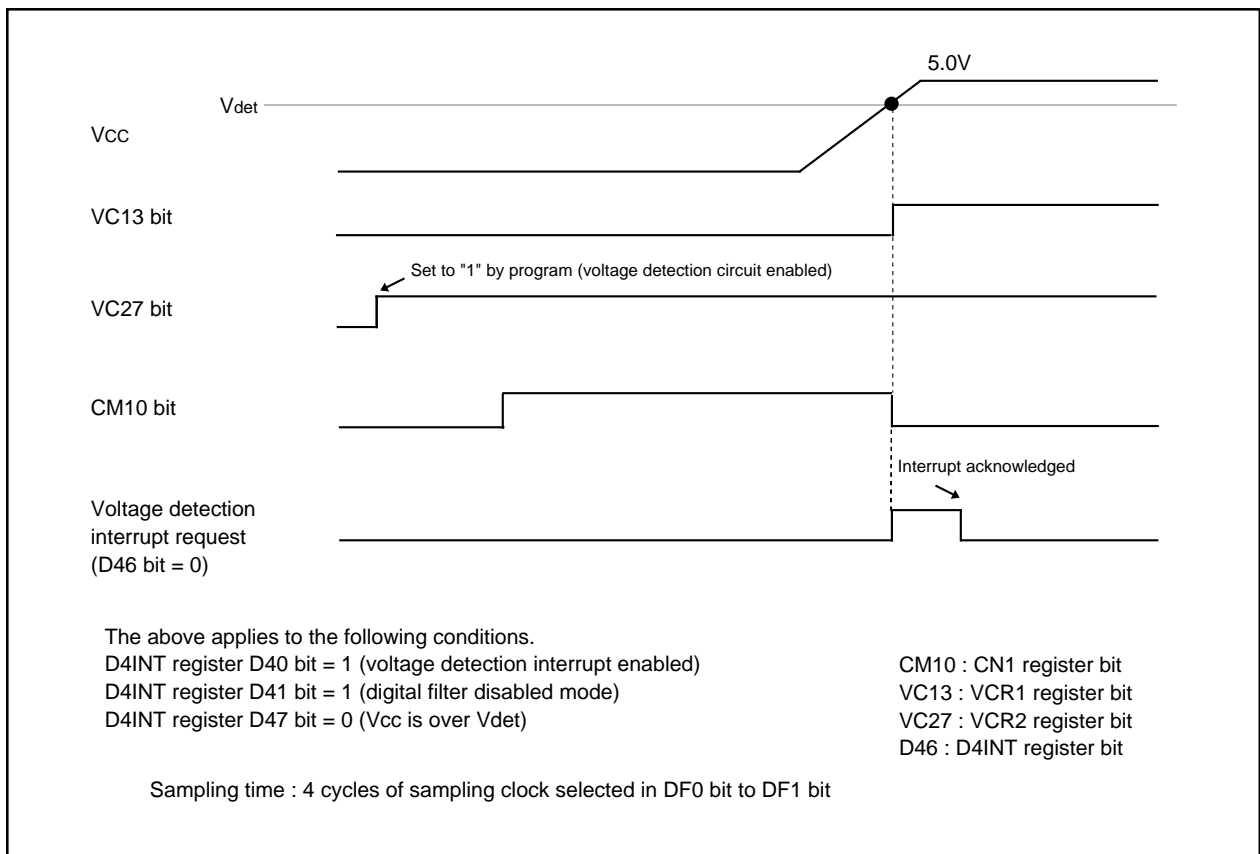

Figure 5.10 Operation Example of Voltage Detection Circuit



**Figure 5.11 Operation Example of Voltage Detection Circuit to get out of Stop mode (1)**



**Figure 5.12 Operation Example of Voltage Detection Circuit to get out of Stop mode (2)**

### 5.4.1 Voltage Detection Interrupt

Figure 5.13 shows the block diagram of voltage detection interrupt generation circuit.

Refer to 5.4.2, "Exiting Stop Mode on a Voltage Detection Circuit" for Getting out of stop mode due to the voltage detection interrupt.

A voltage detection interrupt is generated when the input voltage at the Vcc pin rises to Vdet or more or drops below Vdet if all of the following conditions hold true in normal operation mode and wait mode.

- The VC27 bit in the VCR2 register is set to "1" (voltage detection circuit enabled)
- The D40 bit in the D4INT register is set to "1" (voltage detection interrupt enabled)
- The D46 bit in the D4INT register is set "0" (voltage detection interrupt selected)

To use the digital filter (D41 bit in the D4INT register is set to "0"), set the CM14 bit in the CM1 register to "0" (low-speed on-chip oscillator). Figure 5.14 shows an operation example of voltage detection interrupt generation circuit.

The voltage detection interrupt shares the interrupt vector with the watchdog timer interrupt and oscillation stop detection interrupt.

The D42 bit in the D4INT register becomes "1" when passing through Vdet is detected after the voltage inputted to the Vcc pin is up or down.

A voltage detection interrupt request is generated when the D42 bit changes state from "0" to "1". The D42 bit needs to be set to "0" in a program.

Table 5.2 lists the voltage detection interrupt request generation conditions.

It takes 4 cycles of sampling clock until the D42 bit is set to "1" since the voltage which inputs to Vcc pin passes Vdet.

It is possible to set the sampling clock detecting that the voltage applied to the Vcc pin has passed through Vdet with the DF0 to DF1 bits in the D4INT register.

**Table 5.2 Voltage Detection Interrupt Request Generation Conditions**

Operation mode	VC27 bit	D40 bit	D41 bit	D42 bit	D46 bit	VC13 bit	CM14 bit
Normal operation mode <sup>(1)</sup>	1	1	0 or 1	0	0	From 0 to 1 <sup>(2)</sup>	0
						From 1 to 0 <sup>(2)</sup>	
Wait mode	1	1	0 or 1	0	0	From 0 to 1 <sup>(2)</sup>	0
						From 1 to 0 <sup>(2)</sup>	

**NOTES:**

1. The status except the wait mode and stop mode is handled as the normal mode. (Refer to Chapter 6, "Clock Generation Circuit.")
2. Refer to Figure 5.14, "Operation Example of Voltage Detection Interrupt Generation Circuit" for interrupt generation timing.

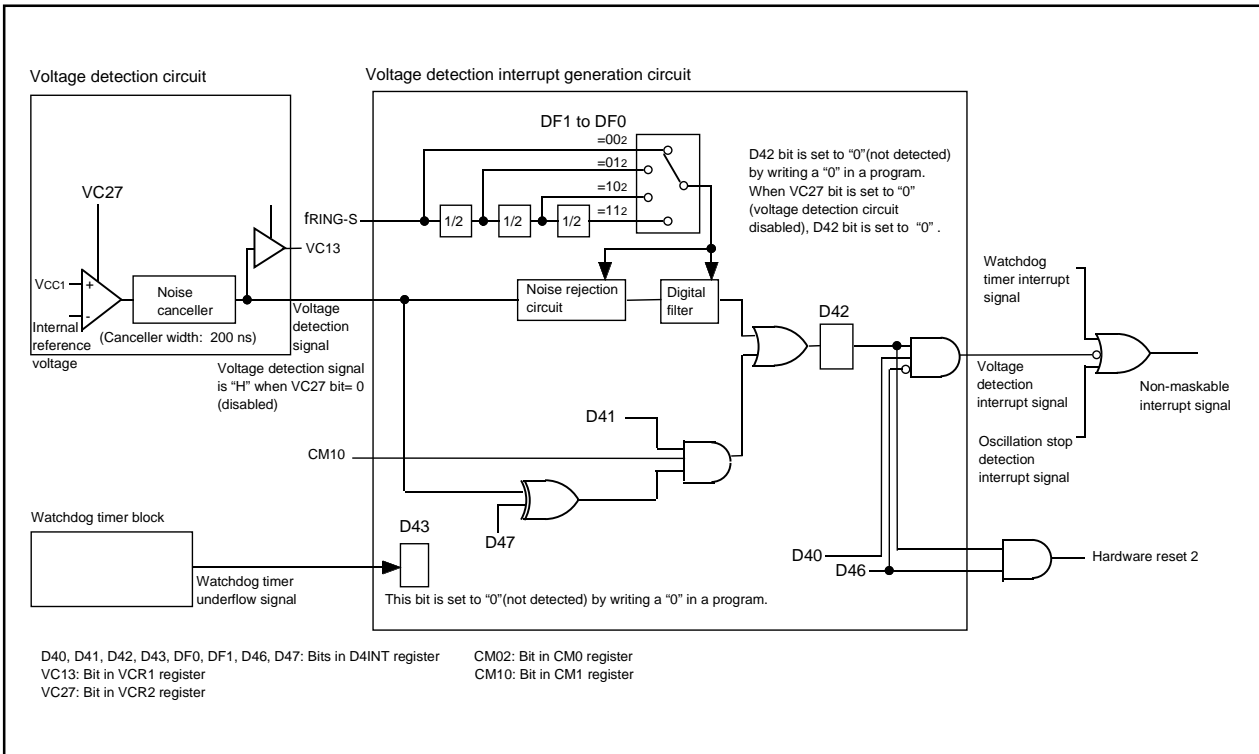

Figure 5.13 Operation Detection Interrupt Generation Block

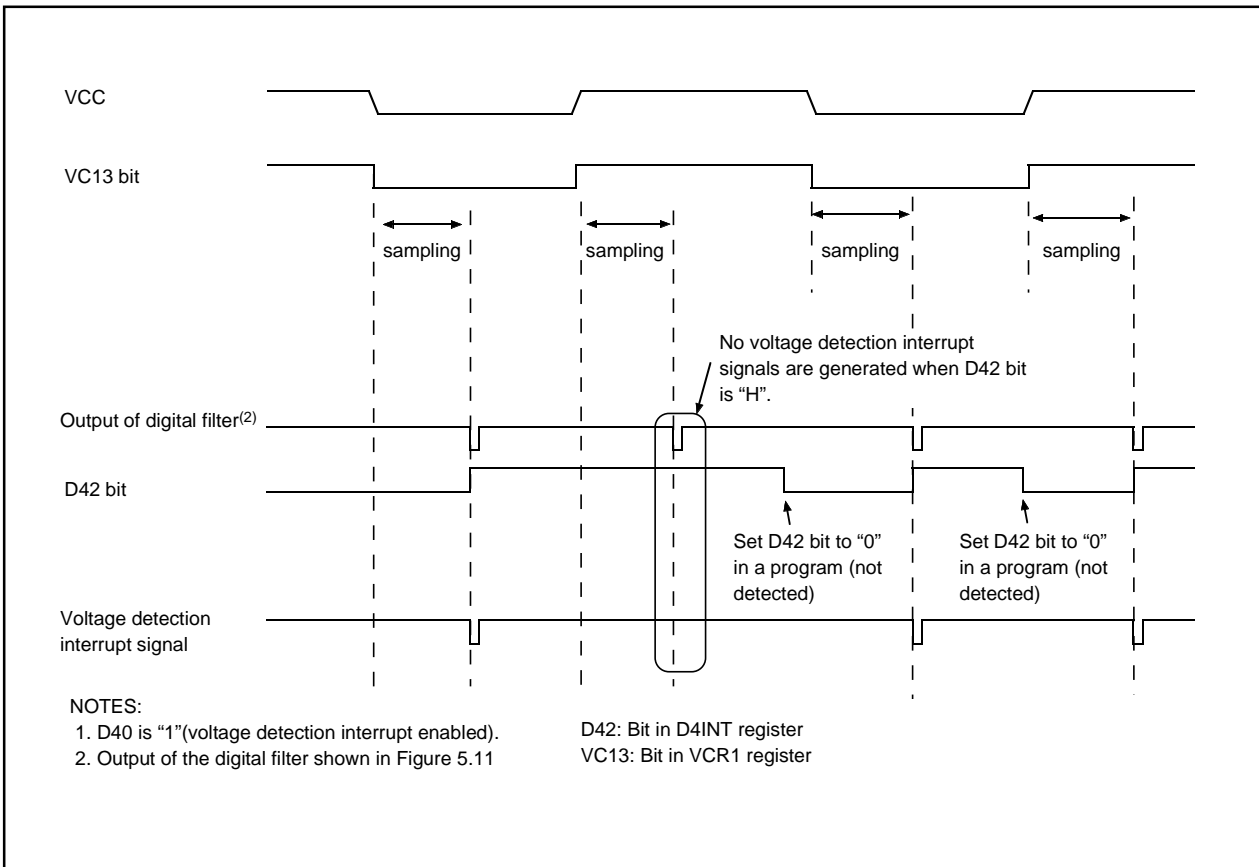

Figure 5.14 Voltage Detection Interrupt Generation Circuit Operation Example

### 5.4.2 Exiting Stop Mode on a Voltage Detection Interrupt

A voltage detection interrupt is generated when the input voltage at the VCC pin rises to Vdet or more or drops below Vdet if all of the following conditions hold true in stop mode.

- The VC27 bit in the VCR2 register is set to "1" (voltage detection circuit enabled)
- The D40 bit in the D4INT register is set to "1" (voltage detection interrupt enabled)
- The D41 bit in the D4INT register is set "1" (digital filter disabled mode)
- The D46 bit in the D4INT register is set "0" (voltage detection interrupt selected)

The voltage detection interrupt shares the interrupt vector with the watchdog timer interrupt and oscillation stop detection interrupt.

The D42 bit in the D4INT register becomes "1" when passing through Vdet is detected after the voltage inputted to the VCC pin is up or down.

A voltage detection interrupt request is generated when the D42 bit changes state from "0" to "1". The D42 bit needs to be set to "0" in a program.

Table 5.3 lists the voltage detection interrupt request generation conditions to get out of stop mode.

**Table 5.3 Voltage Detection Interrupt Request Generation Conditions to get out of Stop mode**

Operation mode	VC27 bit	D40 bit	D41 bit	D42 bit	D46 bit	D47 bit	VC13 bit
Stop mode	1	1	1	0	0	0 or 1	From 0 to 1
							From 1 to 0

**NOTES:**

1. The status except the wait mode and stop mode is handled as the normal mode. (Refer to Chapter 6, "Clock Generation Circuit.")
2. Refer to Figure 5.14, "Operation Example of Voltage Detection Interrupt Generation Circuit" for interrupt generation timing.

## 6. Clock Generation Circuit

The clock generation circuit contains two oscillator circuits as follows:

- Main clock oscillation circuit
- On-chip oscillator (with oscillation stop detection function)

Table 6.1 lists the clock generation circuit specifications. Figure 6.1 shows the clock generation circuit. Figures 6.2 to 6.4 show the clock-related registers.

**Table 6.1 Clock Generation Circuit Specifications**

Item	Main clock oscillation circuit	On-chip oscillator	
		High-speed on-chip oscillator	Low-speed on-chip oscillator
Use of clock	<ul style="list-style-type: none"> <li>• CPU clock source</li> <li>• Peripheral function clock source</li> </ul>	<ul style="list-style-type: none"> <li>• CPU clock source</li> <li>• Peripheral function clock source</li> <li>• CPU and peripheral function clock sources when the main clock stops oscillating</li> </ul>	<ul style="list-style-type: none"> <li>• CPU clock source</li> <li>• Peripheral function clock source</li> <li>• CPU and peripheral function clock sources when the main clock stops oscillating</li> </ul>
Clock frequency	0 to 20 MHz	Approx. 8 MHz	Approx. 125 kHz
Usable oscillator	<ul style="list-style-type: none"> <li>• Ceramic resonator</li> <li>• Crystal oscillator</li> </ul>	_____	_____
Pins to connect oscillator	XIN, XOUT <sup>(1)</sup>	(Note 1)	(Note 1)
Oscillation starts and stops	Present	Present	Present
Oscillator status after reset	Stopped	Stopped	Oscillating
Other	Externally derived clock can be input	_____	_____

**NOTES:**

1. Can be used as P46 and P47 when the on-chip oscillator clock is used for CPU clock while the main clock oscillation circuit is not used.



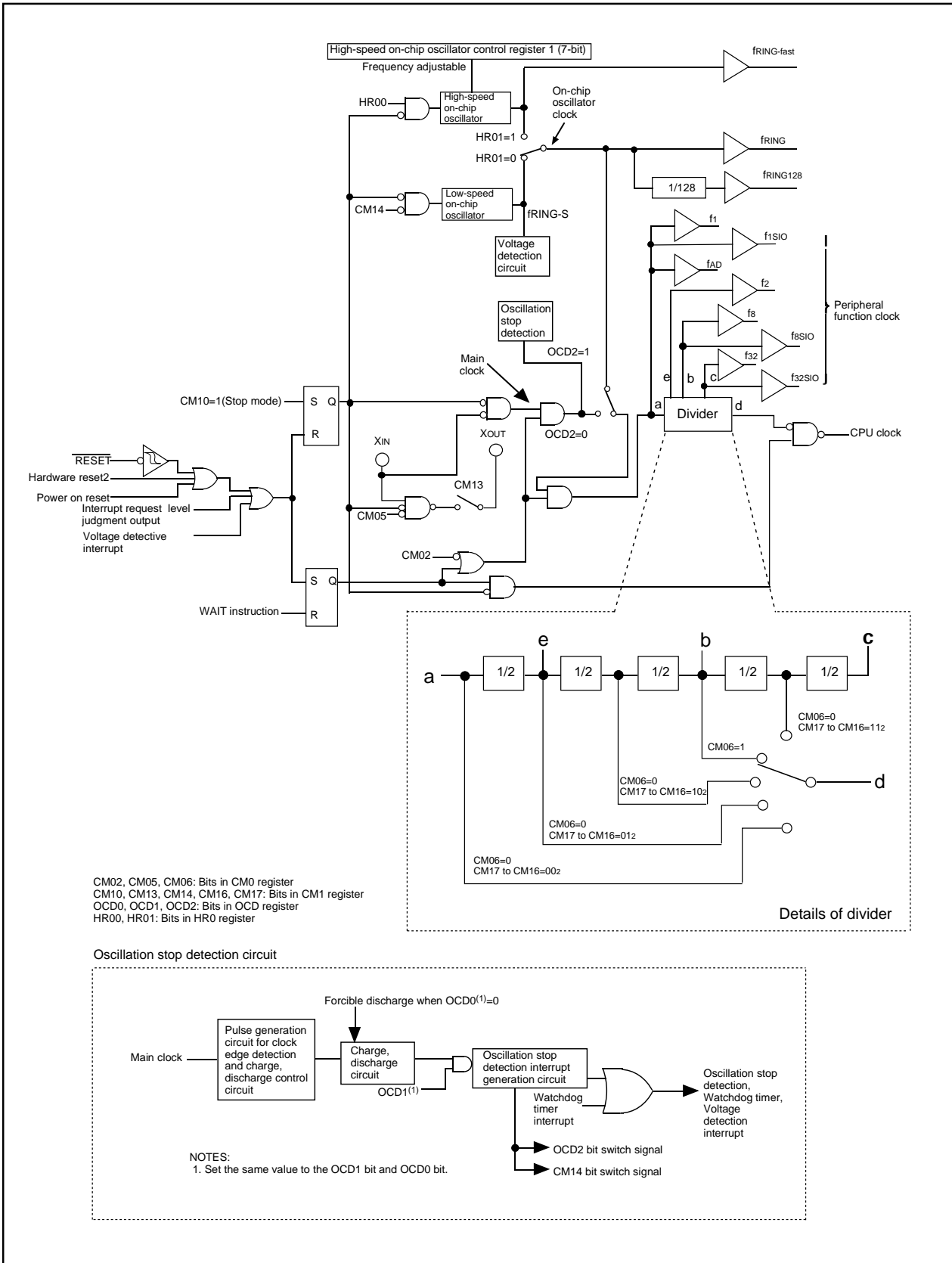

Figure 6.1 Clock Generation Circuit

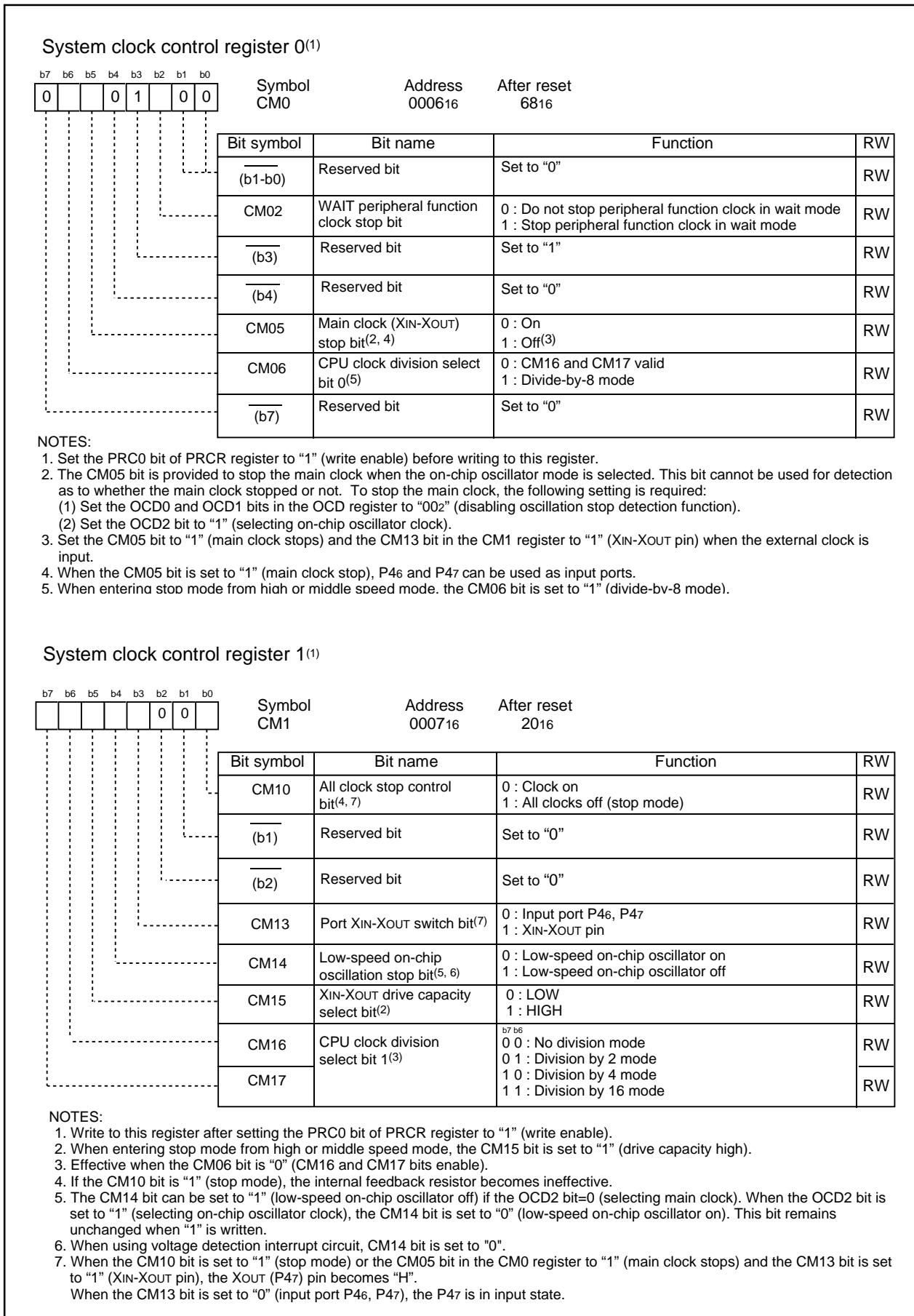

Figure 6.2 CM0 Register and CM1 Register

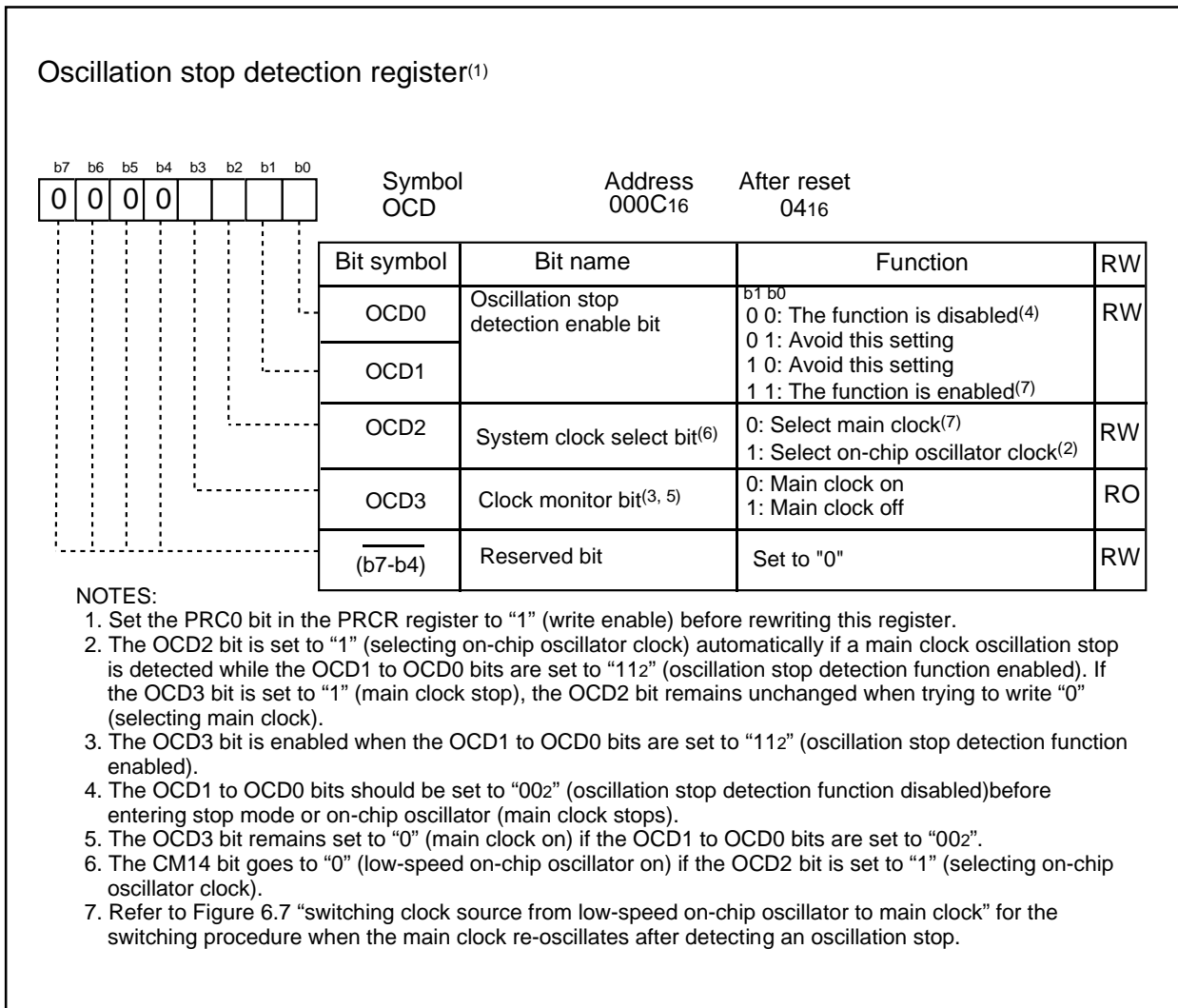

Figure 6.3 OCD Register

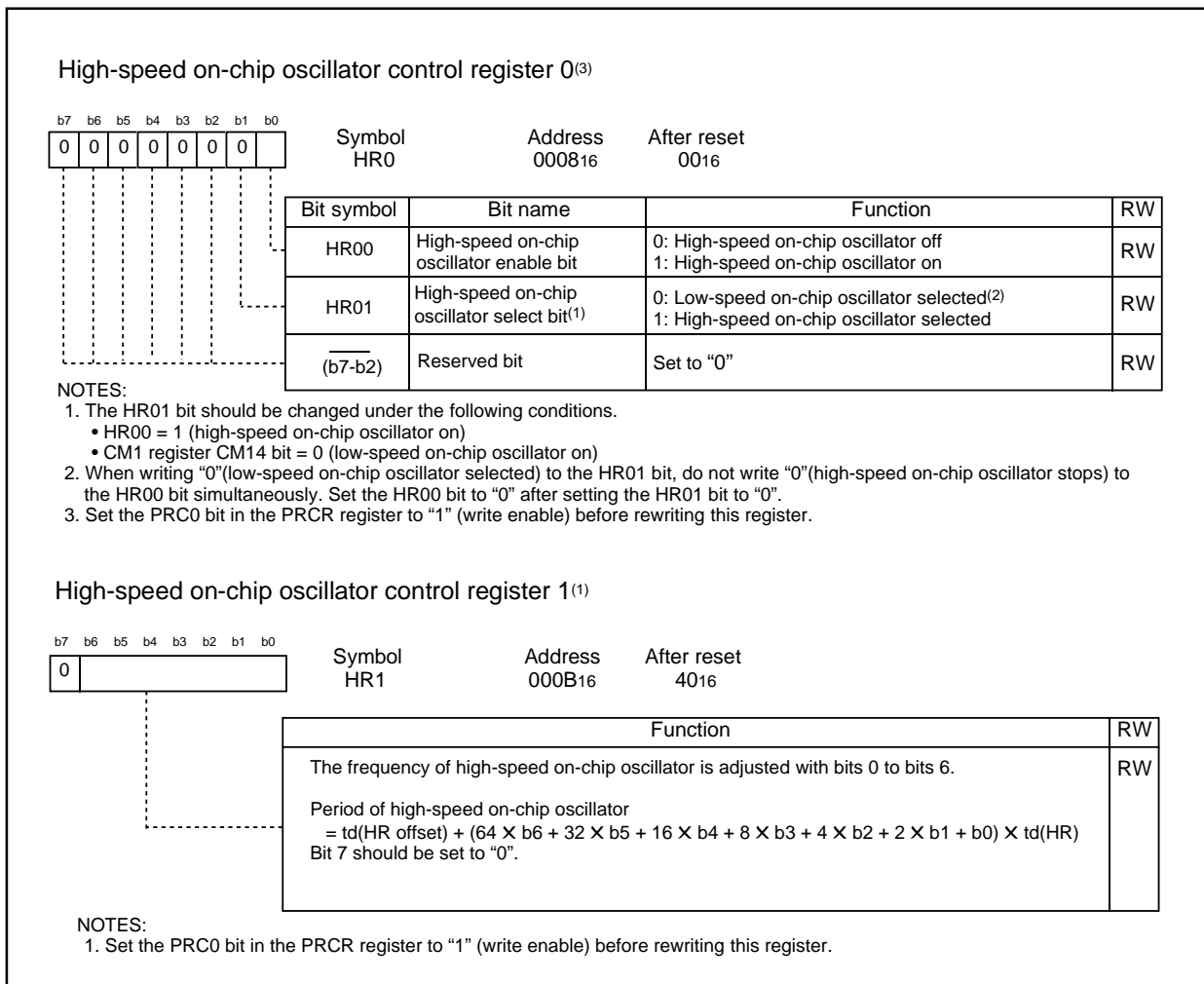

Figure 6.4 HR0 Register and HR1 Register

The following describes the clocks generated by the clock generation circuit.

## 6.1 Main Clock

This clock is supplied by a main clock oscillation circuit. This clock is used as the clock source for the CPU and peripheral function clocks. The main clock oscillator circuit is configured by connecting a resonator between the XIN and XOUT pins. The main clock oscillator circuit contains a feedback resistor, which is disconnected from the oscillator circuit during stop mode in order to reduce the amount of power consumed in the chip. The main clock oscillator circuit may also be configured by feeding an externally generated clock to the XIN pin. Figure 6.5 shows examples of main clock connection circuit.

During reset and after reset, the main clock is turned off.

The main clock starts oscillating when the CM05 bit in the CM0 register is set to "0" (main clock on) after setting the CM13 bit in the CM1 register to "1" (XIN- XOUT pin).

To use the main clock for the CPU clock, set the OCD2 bit in the OCD register to "0" (selecting main clock) after the main clock becomes oscillating stably.

The power consumption can be reduced by setting the CM05 bit in the CM0 register to "1" (main clock off) if the OCD2 bit is set to "1" (selecting on-chip oscillator clock).

Note that if an externally generated clock is fed into the XIN pin, the main clock cannot be turned off by setting the CM05 bit to "1". If necessary, use an external circuit to turn off the clock.

During stop mode, all clocks including the main clock are turned off. Refer to Section 6.4, "Power Control."

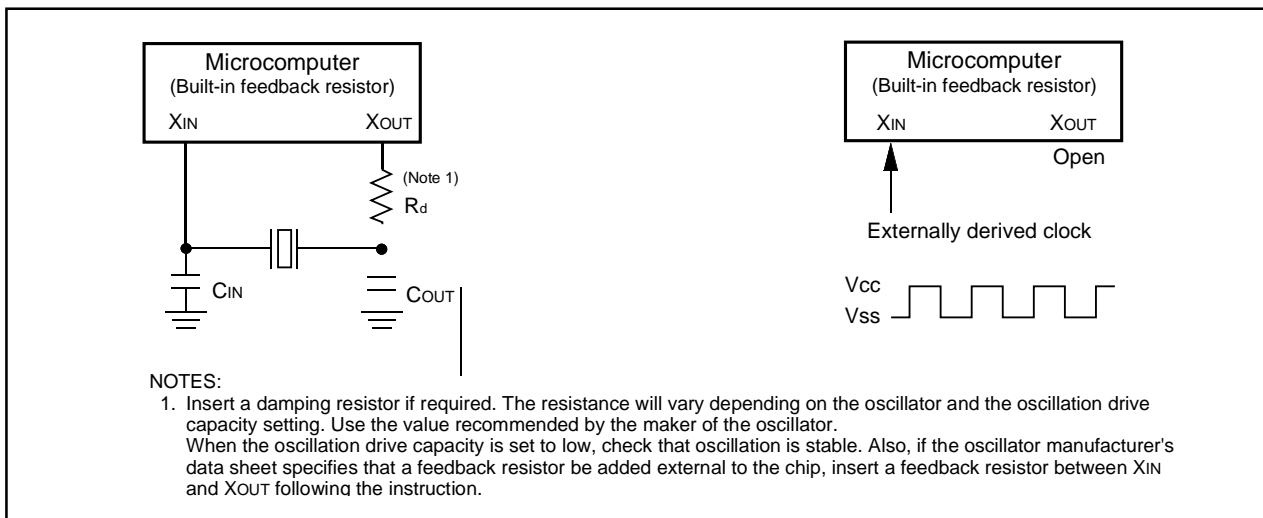

Figure 6.5 Examples of Main Clock Connection Circuit

## 6.2 On-chip Oscillator Clock

This clock is supplied by an on-chip oscillator. There are two kinds of on-chip oscillator: high-speed on-chip oscillator and low-speed on-chip oscillator. These oscillators are selected by the bit HR01 bit in the HR0 register.

### 6.2.1 Low-Speed On-Chip Oscillator Clock

The clock derived from the low-speed on-chip oscillator is used as the clock source for the CPU clock, peripheral function clock, FRING, FRING128 and FRING-S.

After reset, the on-chip oscillator clock derived from low-speed on-chip oscillator by divided by 8 is selected for the CPU clock.

If the main clock stops oscillating when the OCD1 to OCD0 bits in the OCD register are "112" (oscillation stop detection function enabled), the low-speed on-chip oscillator automatically starts operating, supplying the necessary clock for the microcomputer.

The frequency of the low-speed on-chip oscillator varies depending on the supply voltage and the operation ambient temperature. The application products must be designed with sufficient margin for the frequency change.

### 6.2.2 High-Speed On-Chip Oscillator Clock

The clock derived from high-speed on-chip oscillator is used as the clock source for the CPU clock, peripheral function clock, FRING, FRING128, and FRING1-fast.

After reset, the on-chip oscillator clock derived from high-speed on-chip oscillator is halted. The oscillation is started by setting the HR00 bit in the HR0 register to "1" (high-speed on-chip oscillator on). The frequency can be adjusted by the HR1 register.

The relationship between the value of HR1 register and the period of high-speed on-chip oscillator is shown below. It is noted that the difference in delay between the bits should be adjusted by changing each bit. Bit 7 should be set be "0".

$$\text{Period of high-speed on-chip oscillator} = t_d(\text{HR offset}) + (64 \cdot 5^{b6} + 32 \cdot 5^{b5} + 16 \cdot 5^{b4} + 8 \cdot 5^{b3} + 4 \cdot 5^{b2} + 2 \cdot 5^{b1} + 5^{b0})$$

b0 to b6 : Bits in HR1 register

## 6.3 CPU Clock and Peripheral Function Clock

There are two types of clocks: CPU clock to operate the CPU and peripheral function clock to operate the peripheral functions. Also refer to “Figure 6.1 Clock Generation Circuit”.

### 6.3.1 CPU Clock

This is an operating clock for the CPU and watchdog timer.

The clock source for the CPU clock can be chosen to be the main clock or on-chip oscillator clock.

The selected clock source can be divided by 1 (undivided), 2, 4, 8 or 16 to produce the CPU clock. Use the CM06 bit in the CM0 register and the CM17 to CM16 bits in the CM1 register to select the divide-by-n value.

After reset, the low-speed on-chip oscillator clock divided by 8 provides the CPU clock.

Note that when entering stop mode from high or middle speed mode, the CM06 bit is set to “1” (divide-by-8 mode).

### 6.3.2 Peripheral Function Clock (f<sub>1</sub>, f<sub>2</sub>, f<sub>8</sub>, f<sub>32</sub>, f<sub>AD</sub>, f<sub>1SIO</sub>, f<sub>8SIO</sub>, f<sub>32SIO</sub>, f<sub>RING</sub>, f<sub>RING128</sub>)

These are operating clocks for the peripheral functions.

Of these, f<sub>i</sub> (i=1, 2, 8, 32) is derived from the main clock or on-chip oscillator clock by dividing them by i. The clock f<sub>i</sub> is used for timers X, Y, Z and C.

The clock f<sub>jSIO</sub> (j=1, 8, 32) is derived from the main clock or on-chip oscillator clock by dividing them by j. The clock f<sub>jSIO</sub> is used for serial interface.

The f<sub>AD</sub> clock is produced from the main clock or the on-chip oscillator clock and is used for the A/D converter.

When the WAIT instruction is executed after setting the CM02 bit in the CM0 register to “1” (peripheral function clock turned off during wait mode), the clocks f<sub>i</sub>, f<sub>jSIO</sub>, and f<sub>AD</sub> are turned off.

### 6.3.3 f<sub>RING</sub> and f<sub>RING128</sub>

These are operating clocks for the peripheral functions.

The f<sub>RING</sub> runs at the same frequency as the on-chip oscillator, and can be used as the source for the timer Y. The f<sub>RING128</sub> is derived from the f<sub>RING</sub> by dividing it by 128, and can be used for Timer C.

When the WAIT instruction is executed, the clocks f<sub>RING</sub> and f<sub>RING128</sub> are not turned off.

### 6.3.4 f<sub>RING-fast</sub>

This is used as the count source for the timer C. The f<sub>RING-fast</sub> is derived from the high-speed on-chip oscillator and provided by setting the HR00 bit to “1” (high-speed on-chip oscillator on).

When the WAIT instruction is executed, the clock f<sub>RING-fast</sub> is not turned off.

## 6.4 Power Control

There are three power control modes. All modes other than wait and stop modes are referred to as normal operation mode.

### 6.4.1 Normal Operation Mode

Normal operation mode is further classified into four modes.

In normal operation mode, because the CPU clock and the peripheral function clocks both are on, the CPU and the peripheral functions are operating. Power control is exercised by controlling the CPU clock frequency. The higher the CPU clock frequency, the greater the processing capability. The lower the CPU clock frequency, the smaller the power consumption in the chip. If the unnecessary oscillator circuits are turned off, the power consumption is further reduced.

Before the clock sources for the CPU clock can be switched over, the new clock source to which switched must be oscillating stably. If the new clock source is the main clock, allow a sufficient wait time in a program until it becomes oscillating stably.

- **High-speed Mode**

The main clock divided by 1 (undivided) provides the CPU clock. If the CM14 bit is set to "0" (low-speed on-chip oscillator on) or the HR00 bit in the HR0 register is set to "1" (high-speed on-chip oscillator on), the fRING and fRING128 can be used for timers Y and C. When the HR00 bit is set to "1", fRING-fast can be used for timer C.

- **Medium-speed Mode**

The main clock divided by 2, 4, 8 or 16 provides the CPU clock. If the CM14 bit is set to "0" (low-speed on-chip oscillator on) or the HR00 bit in the HR0 register is set to "1" (high-speed on-chip oscillator on), the fRING and fRING128 can be used for timers Y and C. When the HR00 bit is set to "1", fRING-fast can be used for timer C.

- **High-speed, Low-speed, On-Chip Oscillator Mode**

The on-chip oscillator clock divided by 1 (undivided), 2, 4, 8 or 16 provides the CPU clock. The on-chip oscillator clock is also the clock source for the peripheral function clocks. When the HR00 bit is set to "1", fRING-fast can be used for timer C.



**Table 6.2 Setting Clock Related Bit and Modes**

Modes		OCD register	CM1 register		CM0 register	
		OCD2	CM17, CM16	CM13	CM06	CM05
High-speed mode		0	002	1	0	0
Medium-speed mode	divided by 2	0	012	1	0	0
	divided by 4	0	102	1	0	0
	divided by 8	0	—	1	1	0
	divided by 16	0	112	1	0	0
High-speed, low-speed on-chip oscillator mode <sup>(1)</sup>	no division	1	002	—	0	0 or 1
	divided by 2	1	012	—	0	0 or 1
	divided by 4	1	102	—	0	0 or 1
	divided by 8	1	—	—	1	0 or 1
	divided by 16	1	112	—	0	0 or 1

**NOTES:**

1. The low-speed on-chip oscillator is used as the on-chip oscillator clock when the CM1 register CM14 bit=0 (low-speed on-chip oscillator on) and HR0 register HR01 bit=0 (low-speed on-chip oscillator selected).  
The high-speed on-chip oscillator is used as the on-chip oscillator clock when the HR0 register HR00 bit=1 (high-speed on-chip oscillator on) and HR01 bit=1 (high-speed on-chip oscillator selected).

### 6.4.2 Wait Mode

In wait mode, the CPU clock is turned off, so are the CPU and the watchdog timer because both are operated by the CPU clock. Because the main clock and on-chip oscillator clock both are on, the peripheral functions using these clocks keep operating.

#### • Peripheral Function Clock Stop Function

If the CM02 bit is “1” (peripheral function clocks turned off during wait mode), the f1, f2, f8, f32, f1SIO, f8SIO, f32SIO, and fAD clocks are turned off when in wait mode, with the power consumption reduced that much.

#### • Entering Wait Mode

The microcomputer is placed into wait mode by executing the WAIT instruction.

#### • Pin Status During Wait Mode

The status before wait mode is retained.

#### • Exiting Wait Mode

The microcomputer is moved out of wait mode by a hardware reset or peripheral function interrupt. When using a hardware reset to exit wait mode, set the ILVL2 to ILVL0 bits for the peripheral function interrupts to “0002” (interrupts disabled) before executing the WAIT instruction.

The peripheral function interrupts are affected by the CM02 bit. If CM02 bit is “0” (peripheral function clocks not turned off during wait mode), all peripheral function interrupts can be used to exit wait mode. If CM02 bit is “1” (peripheral function clocks turned off during wait mode), the peripheral functions using the peripheral function clocks stop operating, so that only the peripheral functions clocked by external signals can be used to exit from wait mode.

Table 6. 3 lists the interrupts to exit wait mode and the usage conditions.

When using a peripheral function interrupt to exit wait mode, set up the following before executing the WAIT instruction.

1. In the ILVL2 to ILVL0 bits in the interrupt control register, set the interrupt priority level of the peripheral function interrupt to be used to exit wait mode.

Also, for all of the peripheral function interrupts not used to exit wait mode, set the ILVL2 to ILVL0 bits to “0002” (interrupt disable).

2. Set the I flag to “1”.

3. Enable the peripheral function whose interrupt is to be used to exit wait mode.

In this case, when an interrupt request is generated and the CPU clock is thereby turned on, an interrupt sequence is executed.

The CPU clock turned on when exiting wait mode by a peripheral function interrupt is the same CPU clock that was on when the WAIT instruction was executed.

**Table 6.3 Interrupts to Exit Wait Mode and Usage Conditions**

Interrupt	CM02=0	CM02=1
Serial interface interrupt	Can be used when operating with internal or external clock	Can be used when operating with external clock
Key input interrupt	Can be used	Can be used
A/D conversion interrupt	Can be used in one-shot mode	— (Do not use)
Timer X interrupt	Can be used in all modes	Can be used in event counter mode
Timer Y interrupt	Can be used in all modes	Can be used when counting inputs from CNTR1 pin in timer mode
Timer Z interrupt	Can be used in all modes	— (Do not use)
Timer C interrupt	Can be used in all modes	— (Do not use)
INT interrupt	Can be used	Can be used ( $\overline{\text{INT0}}$ and $\overline{\text{INT3}}$ can be used if there is no filter.
Voltage detection interrupt	Can be used	Can be used
Oscillation stop detection interrupt	Can be used	— (Do not use)

### 6.4.3 Stop Mode

In stop mode, all oscillator circuits are turned off, so are the CPU clock and the peripheral function clocks. Therefore, the CPU and the peripheral functions clocked by these clocks stop operating. The least amount of power is consumed in this mode. If the voltage applied to Vcc pin is V<sub>RAM</sub> or more, the internal RAM is retained.

However, the peripheral functions clocked by external signals keep operating. The following interrupts can be used to exit stop mode.

- Key interrupt
- $\overline{\text{INT}}0$  to  $\overline{\text{INT}}2$  interrupts ( $\overline{\text{INT}}0$  can be used only when there is no filter.)
- INT3 interrupt (INT3 can be used when there is no filter and Timer C output compare mode (the TCC13 bit in the TCC1 register is set to "1"))
- Timer X interrupt (when counting external pulses in event counter mode)
- Timer Y interrupt (when counting inputs from CNTR1 pin in timer mode)
- Serial interface interrupt (when external clock is selected)
- Voltage detection interrupt

#### • Entering Stop Mode

The microcomputer is placed into stop mode by setting the CM10 bit of CM1 register to "1" (all clocks turned off). At the same time, the CM06 bit of CM0 register is set to "1" (divide-by-8 mode) and the CM15 bit of CM10 register is set to "1" (main clock oscillator circuit drive capability high).

Before entering stop mode, set the OCD1 to OCD0 bits to "002" (oscillation stop detection function disable).

#### • Pin Status in Stop Mode

The status before wait mode is retained.

However, the XOUT(P47) pin is held "H" when the CM13 bit in the CM1 register is set to "1" (XIN-XOUT pin). The P47(XOUT) is in input state when the CM13 bit is set to "0" (input port P46, P47).

#### • Exiting Stop Mode

The microcomputer is moved out of stop mode by a hardware reset or peripheral function interrupt. When using a hardware reset to exit stop mode, set the ILVL2 to ILVL0 bits for the peripheral function interrupts to "0002" (interrupts disabled) before setting the CM10 bit to "1".

When using a peripheral function interrupt to exit stop mode, set up the following before setting the CM10 bit to "1".

1. In the ILVL2 to ILVL0 bits in the interrupt control register, set the interrupt priority level of the peripheral function interrupt to be used to exit stop mode.  
Also, for all of the peripheral function interrupts not used to exit stop mode, set the ILVL2 to ILVL0 bits to "0002".
2. Set the I flag to "1".
3. Enable the peripheral function whose interrupt is to be used to exit stop mode.  
In this case, when an interrupt request is generated and the CPU clock is thereby turned on, an interrupt sequence is executed.

The main clock divided by 8 of the clock which is used right before stop mode is used for the CPU clock when exiting stop mode by a peripheral function interrupt.

Figure 6.6 shows the state transition of power control.

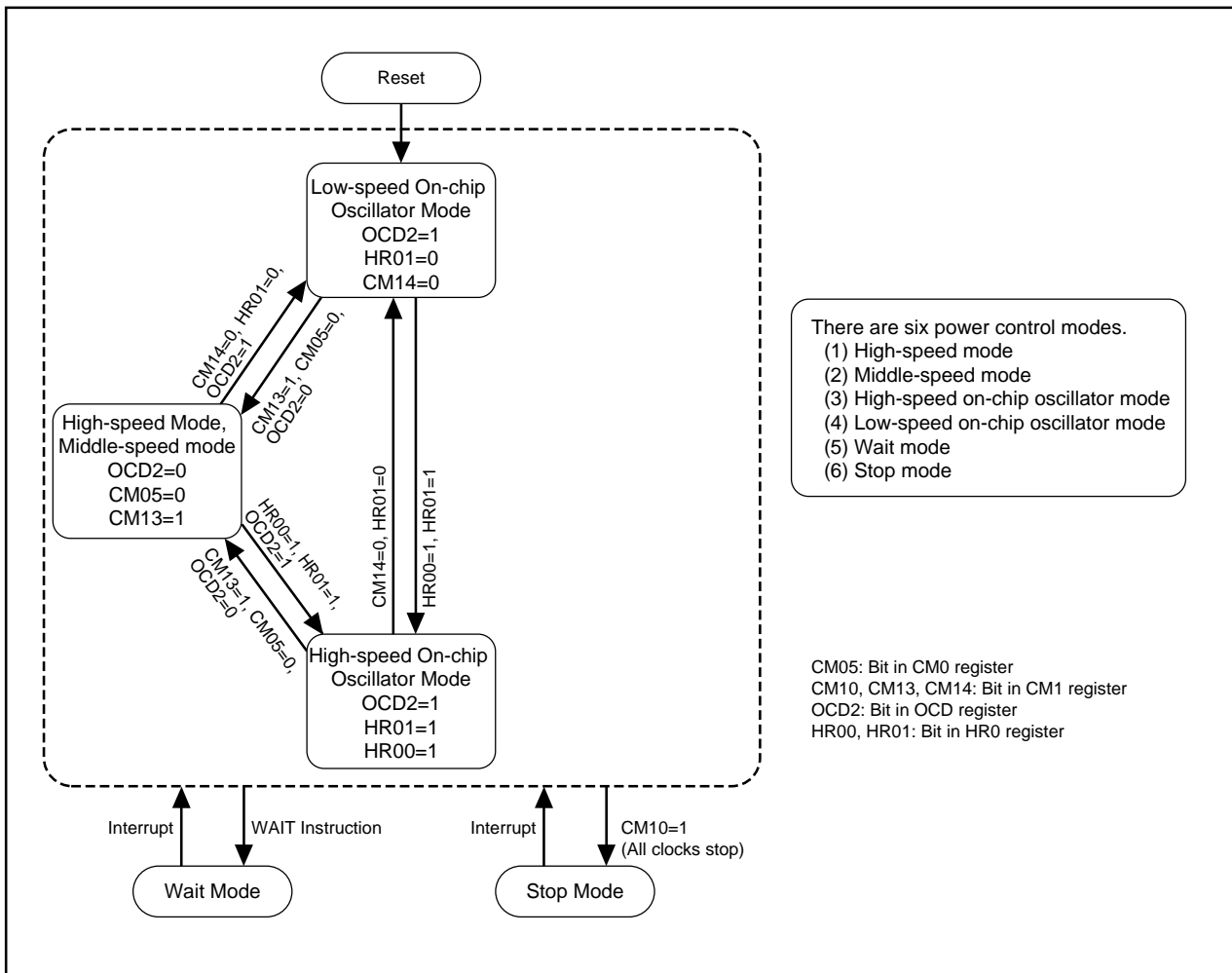

Figure 6.6 State Transition of Power Control

## 6.5 Oscillation Stop Detection Function

The oscillation stop detection function is such that main clock oscillation circuit stop is detected. The oscillation stop detection function can be enabled and disabled by the OCD1 to OCD0 bits in the OCD register.

Table 6.4 lists the specifications of the oscillation stop detection function.

Where the main clock corresponds to the CPU clock source and the OCD1 to OCD0 bits are “112” (oscillation stop detection function enabled), the system is placed in the following state if the main clock comes to a halt:

- OCD register OCD2 bit = 1 (selecting on-chip oscillator clock)
- OCD register OCD3 bit = 1 (main clock stopped)
- CM1 register CM14 bit = 0 (low-speed on-chip oscillator oscillating)
- Oscillation stop detection interrupt request occurs

**Table 6.4 Oscillation Stop Detection Function Specifications**

Item	Specification
Oscillation stop detectable clock and frequency bandwidth	$f(X_{IN}) \geq 2 \text{ MHz}$
Enabling condition for oscillation stop detection function	Set OCD1 to OCD0 bits to “112” (oscillation stop detection function enabled)
Operation at oscillation stop detection	Oscillation stop detection interrupt occurs

### 6.5.1 How to Use Oscillation Stop Detection Function

- The oscillation stop detection interrupt shares the vector with the watchdog timer interrupt. If the oscillation stop detection and watchdog timer interrupts both are used, the interrupt factor must be determined. Table 6.5 shows how to determine the interrupt factor with the oscillation stop detection interrupt, watchdog timer interrupt and voltage detection interrupt.
- Where the main clock re-oscillated after oscillation stop, the clock source for the CPU clock and peripheral functions must be switched to the main clock in the program.  
Figure 6.7 shows the procedure for switching the clock source from the low-speed on-chip oscillator to the main clock.
- To enter wait mode while using the oscillation stop detection function, set the CM02 bit to “0” (peripheral function clocks not turned off during wait mode).
- Since the oscillation stop detection function is provided in preparation for main clock stop due to external factors, set the OCD1 to OCD0 bits to “002” (oscillation stop detection function disabled) where the main clock is stopped or oscillated in the program, that is where the stop mode is selected or the CM05 bit is altered.
- This function cannot be used when the main clock frequency is below 2 MHz. Set the OCD1 to OCD0 bits to “002” (oscillation stop detection function disabled).
- When using the low-speed on-chip oscillator clock for the CPU clock and clock sources of peripheral functions after detecting the oscillation stop, set the HR01 bit in the HR0 register to “0” (low-speed on-chip oscillator selected) and the OCD1 to OCD0 bits to “112” (oscillation stop detection function enabled). When using the high-speed on-chip oscillator clock for the CPU clock and clock sources of peripheral functions after detecting the oscillation stop, set the HR01 bit to “1” (high-speed on-chip oscillator selected) and the OCD1 to OCD0 bits to “112” (oscillation stop detection function enabled).

**Table 6.5 Determination of Interrupt Factor of Oscillation Stop Detection, Watchdog Timer Interrupt or Voltage Detection Interrupt)**

Generated Interrupt Factor	Bit showing interrupt factor
Oscillation stop detection ( (a) or (b) )	(a) The OCD3 bit in the OCD register = 1
	(b) The OCD1 to OCD0 bits in the OCD register = 112 and the OCD2 bit = 1
Watchdog timer	The D43 bit in the D4INT register = 1
Voltage detection	The D42 bit in the D4INT register = 1

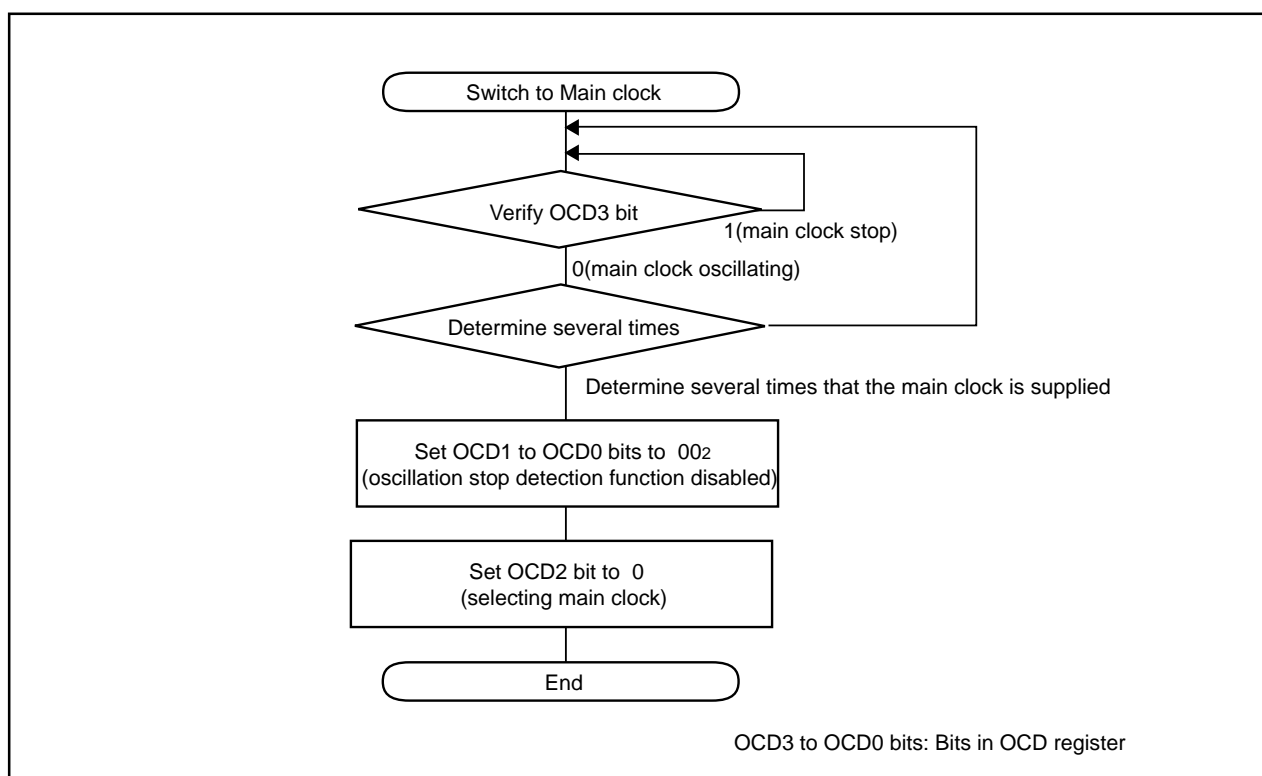

**Figure 6.7 Switching Clock Source From Low-speed On-Chip Oscillator to Main Clock**

## 7. Protection

In the event that a program runs out of control, this function protects the important registers so that they will not be rewritten easily. Figure 7.1 shows the PRCR register. The following lists the registers protected by the PRCR register.

- Registers protected by PRC0 bit: CM0, CM1, and OCD, HR0, HR1 registers
- Registers protected by PRC1 bit: PM0 and PM1 registers
- Registers protected by PRC2 bit: PD0 register
- Registers protected by PRC3 bit: VCR2 and D4INT registers

Set the PRC2 bit to “1” (write enabled) and then write to any address, and the PRC2 bit will be set to “0” (write protected). The registers protected by the PRC2 bit should be changed in the next instruction after setting the PRC2 bit to “1”. Make sure no interrupts will occur between the instruction in which the PRC2 bit is set to “1” and the next instruction. The PRC0, PRC1 and PRC3 bits are not automatically set to “0” by writing to any address. They can only be set to “0” in a program.

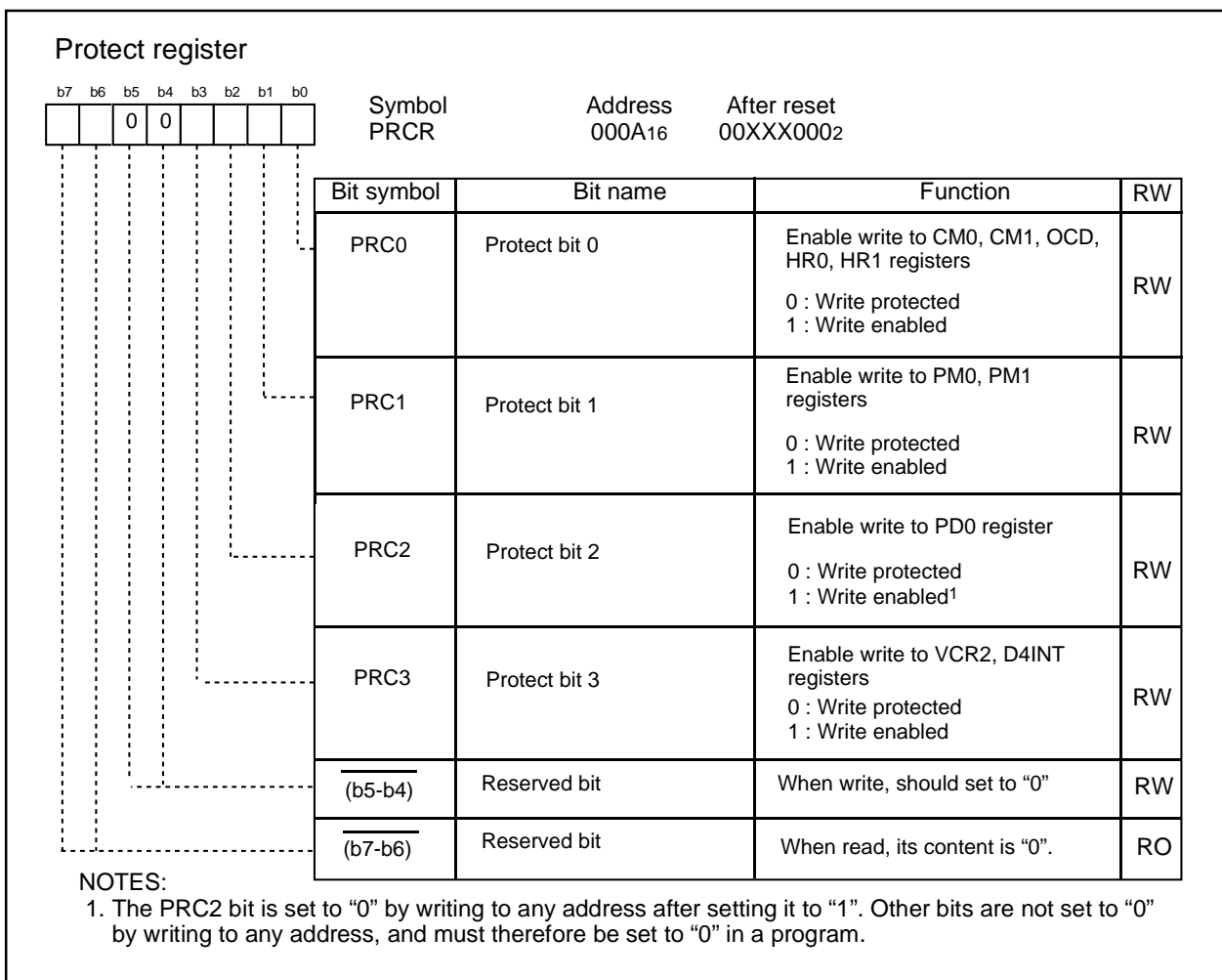

**Figure 7.1 PRCR Register**

## 8. Processor Mode

### 8.1 Types of Processor Mode

The processor mode is single-chip mode. Table 8.1 shows the features of the processor mode. Figure 8.1 shows the PM0 and PM1 register.

**Table 8.1 Features of Processor Mode**

Processor mode	Access space	Pins which are assigned I/O ports
Single-chip mode	SFR, internal RAM, internal ROM	All pins are I/O ports or peripheral function I/O pins

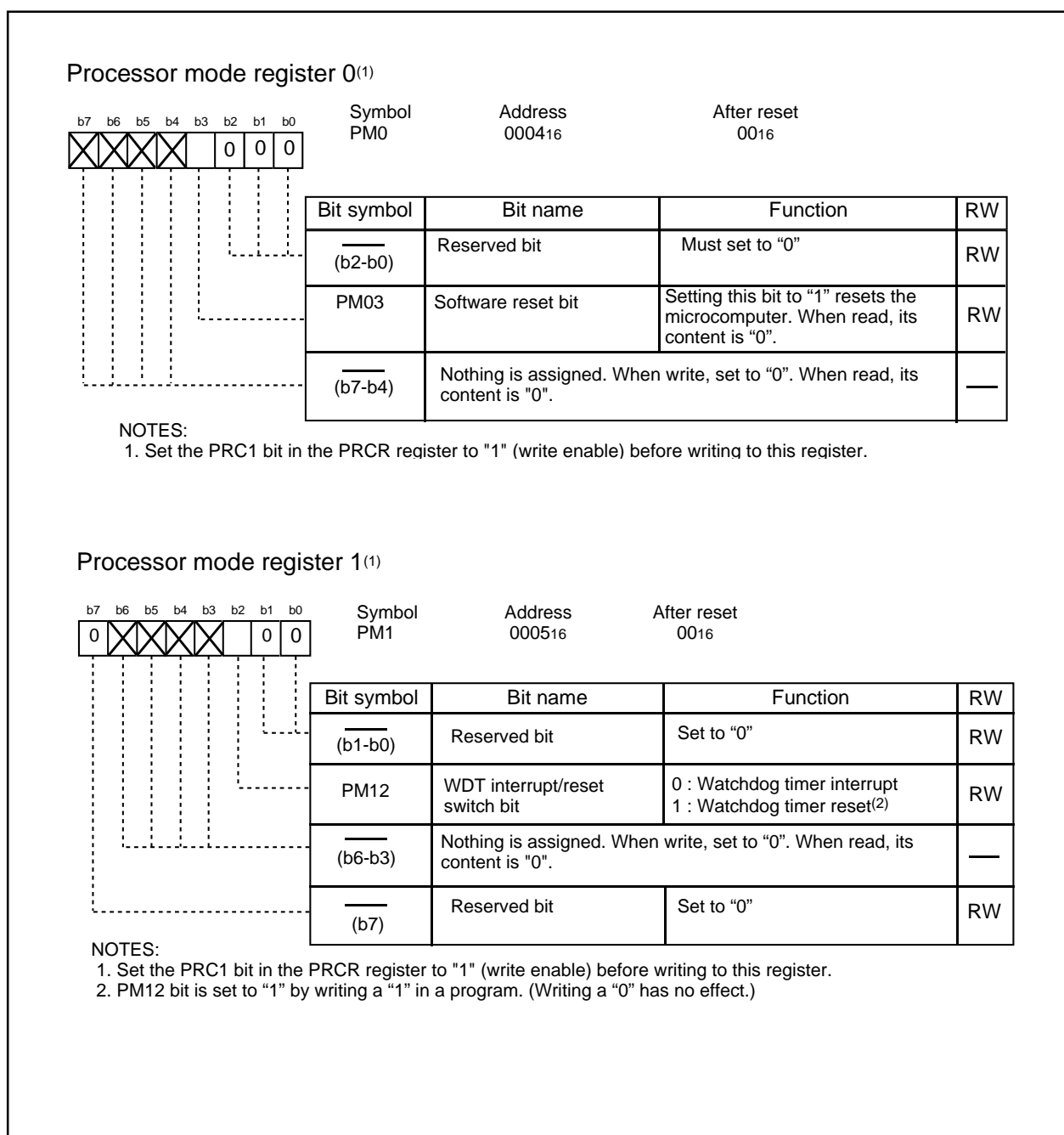

**Figure 8.1 PM0 Register and PM1 Register**



## 9. Bus

During access, the ROM/RAM and the SFR have different bus cycles. Table 9.1 shows bus cycles for access space.

The ROM/RAM and SFR are connected to the CPU through an 8-bit bus. When accessing in word (16 bits) units, these spaces are accessed twice in 8-bit units. Table 9.2 shows bus cycles in each access space.

**Table 9.1 Bus Cycles for Access Space**

Access space	Bus cycle
SFR/Data flash	2 CPU clock cycles
Program ROM/RAM	1 CPU clock cycles

**Table 9.2 Access Unit and Bus Operation**

Space	SFR, Data flash	Program ROM/RAM
Even address byte access		
Odd address byte access		
Even address word access		
Odd address word access		

# 10. Interrupt

## 10.1 Interrupt Overview

### 10.1.1 Type of Interrupts

Figure 10.1 shows types of interrupts.

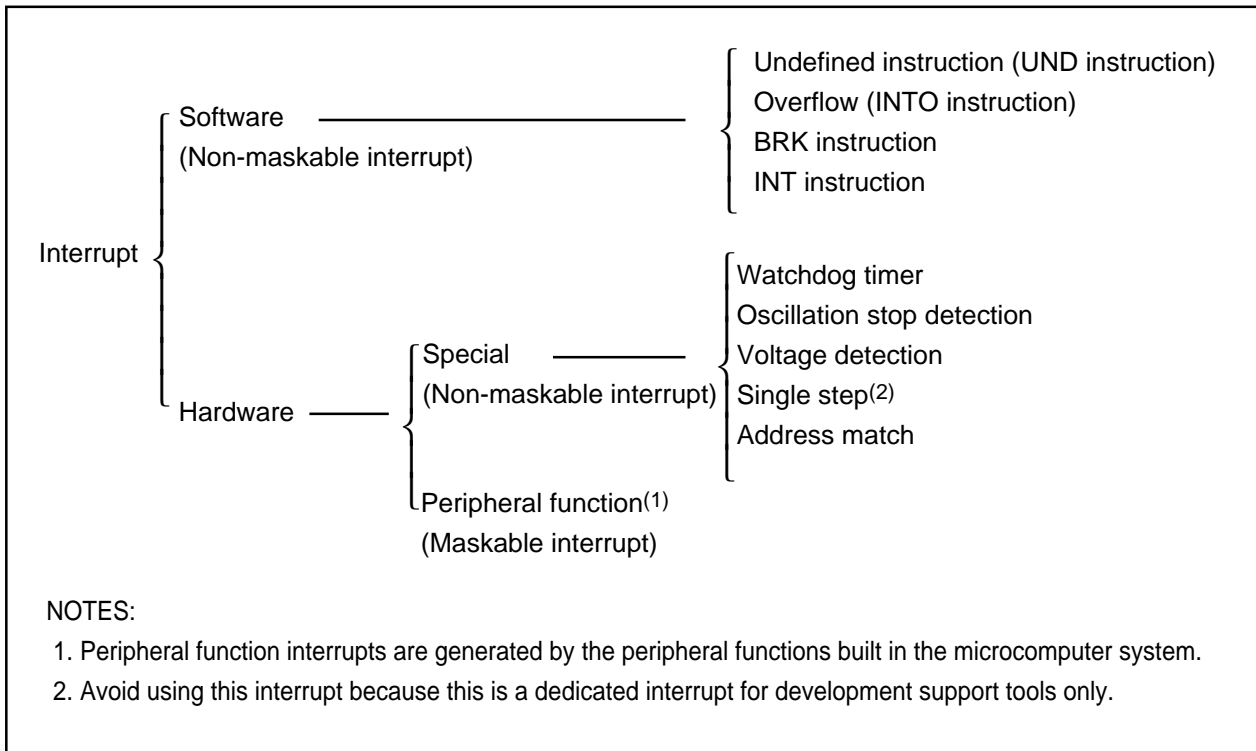

**Figure 10.1 Interrupts**

- Maskable Interrupt: An interrupt which can be enabled (disabled) by the interrupt enable flag (I flag) or whose interrupt priority **can be changed** by priority level.
- Non-maskable Interrupt: An interrupt which cannot be enabled (disabled) by the interrupt enable flag (I flag) or whose interrupt priority **cannot be changed** by priority level.

### 10.1.2 Software Interrupts

A software interrupt occurs when executing certain instructions. Software interrupts are non-maskable interrupts.

- **Undefined Instruction Interrupt**

An undefined instruction interrupt occurs when executing the UND instruction.

- **Overflow Interrupt**

An overflow interrupt occurs when executing the INTO instruction with the O flag set to "1" (the operation resulted in an overflow). The following are instructions whose O flag changes by arithmetic:

ABS, ADC, ADCF, ADD, CMP, DIV, DIVU, DIVX, NEG, RMPA, SBB, SHA, SUB

- **BRK Interrupt**

A BRK interrupt occurs when executing the BRK instruction.

- **INT Instruction Interrupt**

An INT instruction interrupt occurs when executing the INT instruction. Software interrupt numbers 0 to 63 can be specified for the INT instruction. Because software interrupt numbers 4 to 31 are assigned to peripheral function interrupts, the same interrupt routine as for peripheral function interrupts can be executed by executing the INT instruction.

In software interrupt numbers 0 to 31, the U flag is saved to the stack during instruction execution and is cleared to "0" (ISP selected) before executing an interrupt sequence. The U flag is restored from the stack when returning from the interrupt routine. In software interrupt numbers 32 to 63, the U flag does not change state during instruction execution, and the SP then selected is used.

### 10.1.3 Hardware Interrupts

Hardware interrupts are classified into two types — special interrupts and peripheral function interrupts.

#### (1) Special Interrupts

Special interrupts are non-maskable interrupts.

- **Watchdog Timer Interrupt**

Generated by the watchdog timer. Once a watchdog timer interrupt is generated, be sure to initialize the watchdog timer. For details about the watchdog timer, refer to Chapter 11, “Watchdog Timer.”

- **Oscillation Stop Detection Interrupt**

Generated by the oscillation stop detection function. For details about the oscillation stop detection function, refer to Chapter 6, “Clock Generation Circuit.”

- **Voltage Detection Interrupt**

Generated by the voltage detection circuit. For details about the voltage detection circuit, refer to Section 5.4, “Voltage Detection Circuit.”

- **Single-step Interrupt**

Do not normally use this interrupt because it is provided exclusively for use by development support tools.

- **Address Match Interrupt**

An address match interrupt is generated immediately before executing the instruction at the address indicated by the RMAD0 to RMAD1 register that corresponds to one of the AIER register's AIER0 or AIER1 bit which is "1" (address match interrupt enabled). For details about the address match interrupt, refer to Section 10.4, “Address Match Interrupt.”

#### (2) Peripheral Function Interrupts

Peripheral function interrupts are maskable interrupts and generated by the microcomputer's internal functions. The interrupt factors for peripheral function interrupts are listed in Table 10.2. “Relocatable Vector Tables”. For details about the peripheral functions, refer to the description of each peripheral function in this manual.

### 10.1.4 Interrupts and Interrupt Vector

One interrupt vector consists of 4 bytes. Set the start address of each interrupt routine in the respective interrupt vectors. When an interrupt request is accepted, the CPU branches to the address set in the corresponding interrupt vector. Figure 10.2 shows the interrupt vector.

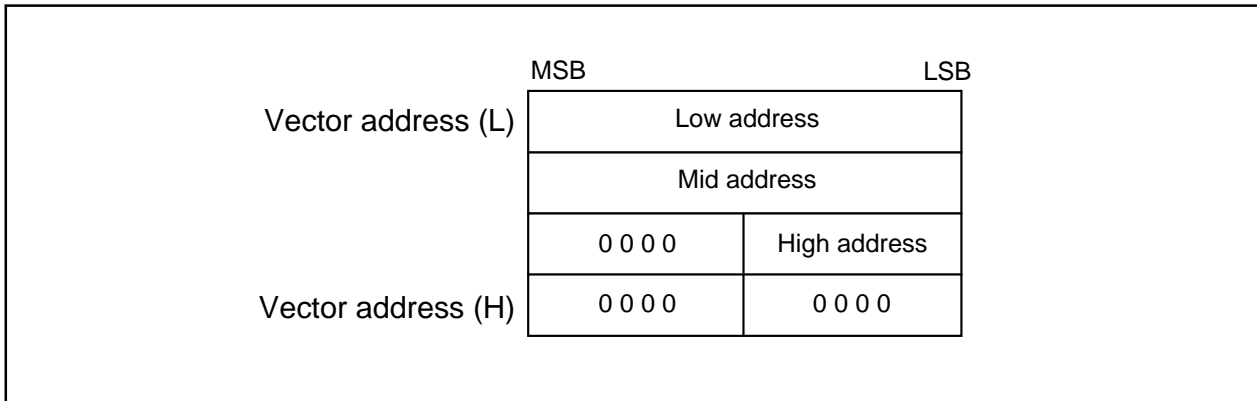

**Figure 10.2** Interrupt Vector

#### • Fixed Vector Tables

The fixed vector tables are allocated to the addresses from 0FFDC<sub>16</sub> to 0FFFF<sub>16</sub>. Table 10.1 lists the fixed vector tables. In the flash memory version of microcomputer, the vector addresses (H) of fixed vectors are used by the ID code check function. For details, refer to Section 17.3, "Functions to Prevent Flash Memory from Rewriting."

**Table 10.1** Fixed Vector Tables

Interrupt factor	Vector addresses Address (L) to address (H)	Remarks	Reference
Undefined instruction	0FFDC <sub>16</sub> to 0FFDF <sub>16</sub>	Interrupt on UND instruction	R8C/Tiny series software manual
Overflow	0FFE0 <sub>16</sub> to 0FFE3 <sub>16</sub>	Interrupt on INTO instruction	
BRK instruction	0FFE4 <sub>16</sub> to 0FFE7 <sub>16</sub>	If the contents of address 0FFE7 <sub>16</sub> is FF <sub>16</sub> , program execution starts from the address shown by the vector in the relocatable vector table.	
Address match	0FFE8 <sub>16</sub> to 0FFEB <sub>16</sub>		18.1 Address match interrupt
Single step <sup>(1)</sup>	0FFEC <sub>16</sub> to 0FFEF <sub>16</sub>		
<ul style="list-style-type: none"> <li>• Watchdog timer</li> <li>• Oscillation stop detection</li> <li>• Voltage detection</li> </ul>	0FFF0 <sub>16</sub> to 0FFF3 <sub>16</sub>		11. Watchdog timer 6. Clock generation circuit 5.4 Voltage detection circuit
(Reserved)	0FFF4 <sub>16</sub> to 0FFF7 <sub>16</sub>		
(Reserved)	0FFF8 <sub>16</sub> to 0FFFB <sub>16</sub>		
Reset	0FFFC <sub>16</sub> to 0FFFF <sub>16</sub>		5. Reset

#### NOTES:

- Do not normally use this interrupt because it is provided exclusively for use by development support tools.

- **Relocatable Vector Tables**

The 256 bytes beginning with the start address set in the INTB register comprise a relocatable vector table area. Table 10.2 lists interrupts and vector tables located in the relocatable vector table.

**Table 10.2 Vector Tables**

Interrupt factor	Vector address <sup>(1)</sup> Address (L) to address (H)	Software interrupt number	Reference
BRK instruction <sup>(2)</sup>	+0 to +3 (0000 <sub>16</sub> to 0003 <sub>16</sub> )	0	R8C/Tiny Series software manual
———— (Reserved)		1 to 12	
Key input	+52 to +55 (0034 <sub>16</sub> to 0037 <sub>16</sub> )	13	10.3 Key input interrupt
A/D Conversion	+56 to +59 (0038 <sub>16</sub> to 003B <sub>16</sub> )	14	14. A/D converter
———— (Reserved)		15	
Compare 1	+64 to +67 (0040 <sub>16</sub> to 0043 <sub>16</sub> )	16	12.4 Timer C
UART0 transmit	+68 to +71 (0044 <sub>16</sub> to 0047 <sub>16</sub> )	17	13. Serial Interface
UART0 receive	+72 to +75 (0048 <sub>16</sub> to 004B <sub>16</sub> )	18	
UART1 transmit	+76 to +79 (004C <sub>16</sub> to 004F <sub>16</sub> )	19	
UART1 receive	+80 to +83 (0050 <sub>16</sub> to 0053 <sub>16</sub> )	20	
$\overline{\text{INT}}2$	+84 to +87 (0054 <sub>16</sub> to 0057 <sub>16</sub> )	21	10.2.3 $\overline{\text{INT}}2$ interrupt
Timer X	+88 to +91 (0058 <sub>16</sub> to 005B <sub>16</sub> )	22	12.1 Timer X
Timer Y	+92 to +95 (005C <sub>16</sub> to 005F <sub>16</sub> )	23	12.2 Timer Y
Timer Z	+96 to +99 (0060 <sub>16</sub> to 0063 <sub>16</sub> )	24	12.3 Timer Z
$\overline{\text{INT}}1$	+100 to +103 (0064 <sub>16</sub> to 0067 <sub>16</sub> )	25	10.2.3 $\overline{\text{INT}}1$ interrupt
$\overline{\text{INT}}3$	+104 to +107 (0068 <sub>16</sub> to 006B <sub>16</sub> )	26	10.2.4 $\overline{\text{INT}}3$ interrupt
Timer C	+108 to +111 (006C <sub>16</sub> to 006F <sub>16</sub> )	27	12.4 Timer C
Compare 0	+112 to +115 (0070 <sub>16</sub> to 0073 <sub>16</sub> )	28	12.4 Timer C
$\overline{\text{INT}}0$	+116 to +119 (0074 <sub>16</sub> to 0077 <sub>16</sub> )	29	10.2.1 $\overline{\text{INT}}0$ interrupt
———— (Reserved)		30	
———— (Reserved)		31	
Software interrupt <sup>(2)</sup>	+128 to +131 (0080 <sub>16</sub> to 0083 <sub>16</sub> ) to +252 to +255 (00FC <sub>16</sub> to 00FF <sub>16</sub> )	32 to 63	R8C/Tiny Series software manual

**NOTES:**

1. Address relative to address in INTB.
2. These interrupts cannot be disabled using the I flag.

### 10.1.5 Interrupt Control

The following describes how to enable/disable the maskable interrupts, and how to set the priority in which order they are accepted. What is explained here does not apply to nonmaskable interrupts.

Use the FLG register's I flag, IPL, and each interrupt control register's ILVL2 to ILVL0 bits to enable/disable the maskable interrupts. Whether an interrupt is requested is indicated by the IR bit in each interrupt control register.

Figure 10.3 shows the interrupt control registers.

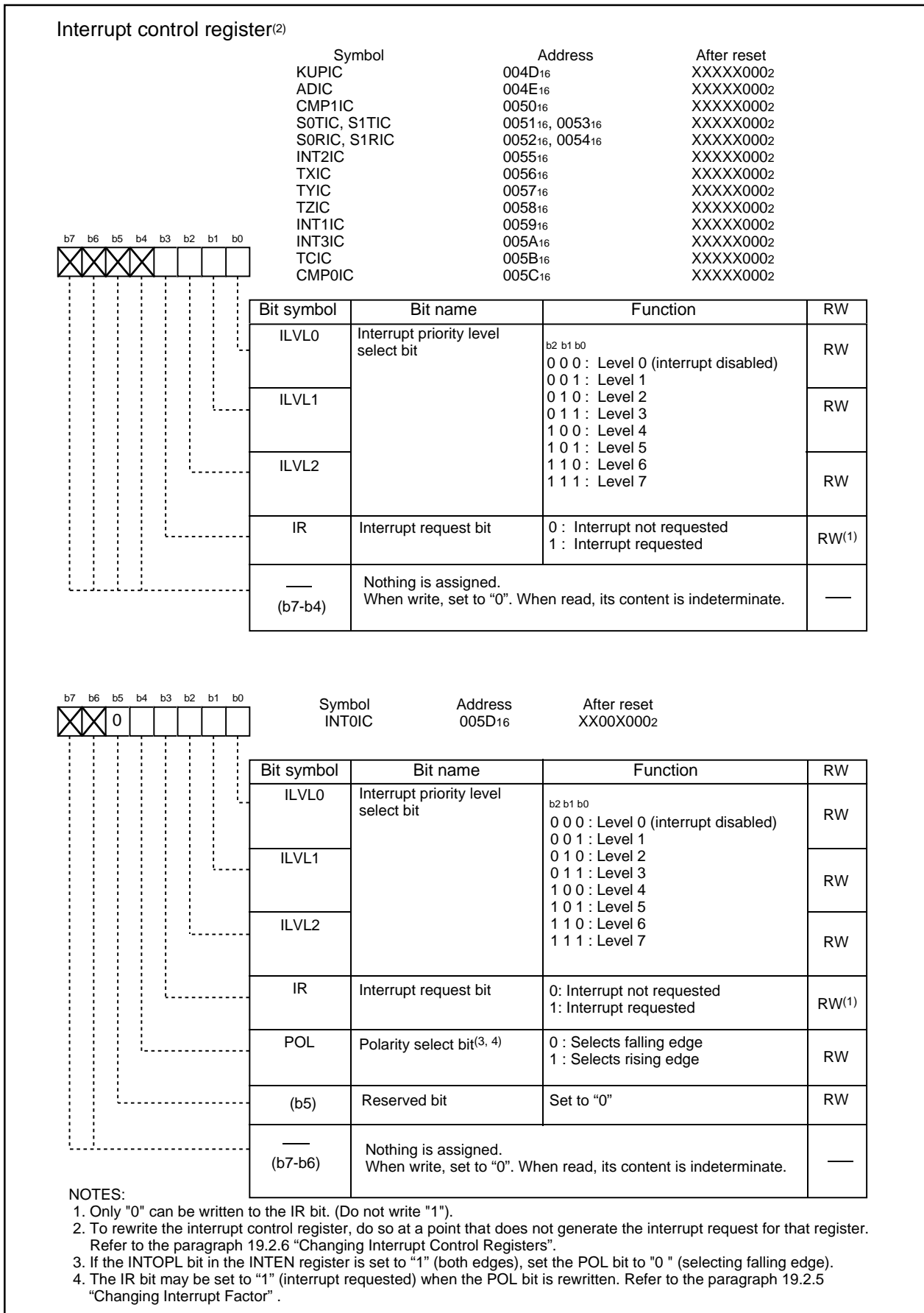

**Figure 10.3 Interrupt Control Registers**



- **I Flag**

The I flag enables or disables the maskable interrupt. Setting the I flag to “1” (enabled) enables the maskable interrupt. Setting the I flag to “0” (disabled) disables all maskable interrupts.

- **IR Bit**

The IR bit is set to “1” (interrupt requested) when an interrupt request is generated. Then, when the interrupt request is accepted and the CPU branches to the corresponding interrupt vector, the IR bit is cleared to “0” (= interrupt not requested).

The IR bit can be cleared to “0” in a program. Note that do not write “1” to this bit.

- **ILVL2 to ILVL0 Bits and IPL**

Interrupt priority levels can be set using the ILVL2 to ILVL0 bits.

Table 10.3 shows the settings of interrupt priority levels and Table 10.4 shows the interrupt priority levels enabled by the IPL.

The following are conditions under which an interrupt is accepted:

- I flag = 1
- IR bit = 1
- interrupt priority level > IPL

The I flag, IR bit, ILVL2 to ILVL0 bits and IPL are independent of each other. In no case do they affect one another.

**Table 10.3 Settings of Interrupt Priority Levels**

ILVL2 to ILVL0 bits	Interrupt priority level	Priority order
0002	Level 0 (interrupt disabled)	————
0012	Level 1	Lowest  Highest
0102	Level 2	
0112	Level 3	
1002	Level 4	
1012	Level 5	
1102	Level 6	
1112	Level 7	

**Table 10.4 Interrupt Priority Levels Enabled by IPL**

IPL	Enabled interrupt priority levels
0002	Interrupt levels 1 and above are enabled
0012	Interrupt levels 2 and above are enabled
0102	Interrupt levels 3 and above are enabled
0112	Interrupt levels 4 and above are enabled
1002	Interrupt levels 5 and above are enabled
1012	Interrupt levels 6 and above are enabled
1102	Interrupt levels 7 and above are enabled
1112	All maskable interrupts are disabled

### • Interrupt Sequence

An interrupt sequence — what are performed over a period from the instant an interrupt is accepted to the instant the interrupt routine is executed — is described here.

If an interrupt occurs during execution of an instruction, the processor determines its priority when the execution of the instruction is completed, and transfers control to the interrupt sequence from the next cycle. If an interrupt occurs during execution of either the SMOVB, SMOVF, SSTR or RMPA instruction, the processor temporarily suspends the instruction being executed, and transfers control to the interrupt sequence.

The CPU behavior during the interrupt sequence is described below. Figure 10.4 shows time required for executing the interrupt sequence.

- (1) The CPU gets interrupt information (interrupt number and interrupt request priority level) by reading the address 00000<sub>16</sub>. Then it clears the IR bit for the corresponding interrupt to “0” (interrupt not requested).
- (2) The FLG register immediately before entering the interrupt sequence is saved to the CPU internal temporary register<sup>(1)</sup>.
- (3) The I, D and U flags in the FLG register become as follows:
  - The I flag is cleared to “0” (interrupts disabled).
  - The D flag is cleared to “0” (single-step interrupt disabled).
  - The U flag is cleared to “0” (ISP selected).
 However, the U flag does not change state if an INT instruction for software interrupt numbers 32 to 63 is executed.
- (4) The CPU's internal temporary register <sup>(1)</sup> is saved to the stack.
- (5) The PC is saved to the stack.
- (6) The interrupt priority level of the accepted interrupt is set in the IPL.
- (7) The start address of the relevant interrupt routine set in the interrupt vector is stored in the PC.

After the interrupt sequence is completed, the processor resumes executing instructions from the start address of the interrupt routine.

#### NOTES:

1. This register cannot be used by user.

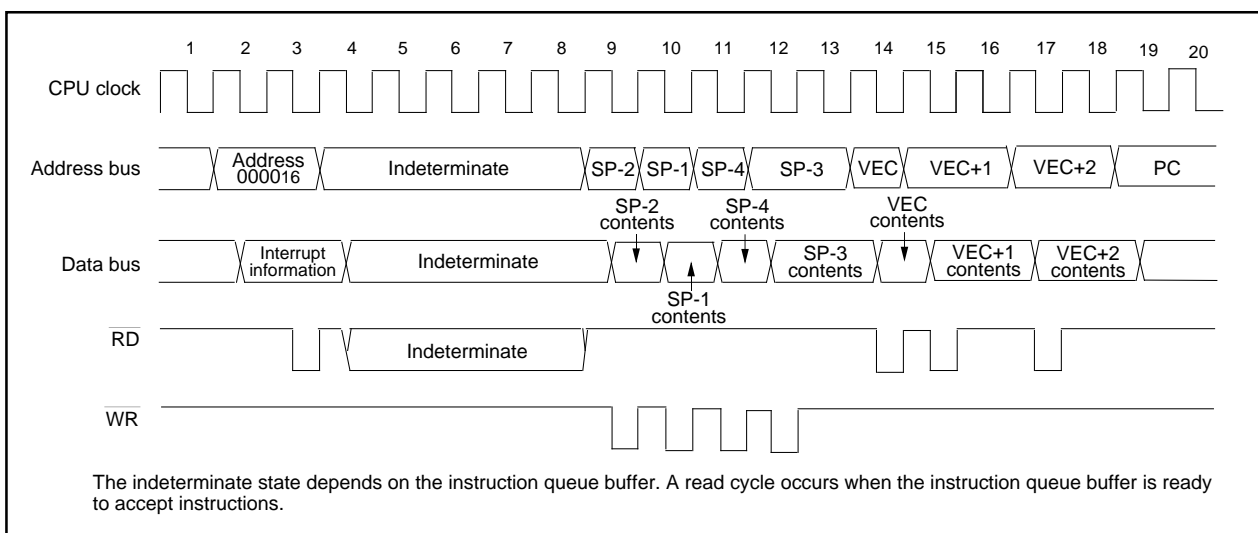

**Figure 10.4 Time Required for Executing Interrupt Sequence**

### • Interrupt Response Time

Figure 10.5 shows the interrupt response time. The interrupt response or interrupt acknowledge time denotes a time from when an interrupt request is generated till when the first instruction in the interrupt routine is executed. Specifically, it consists of a time from when an interrupt request is generated till when the instruction then executing is completed (see #a in Figure 10.5) and a time during which the interrupt sequence is executed (20 cycles, see #b in Figure 10.5).

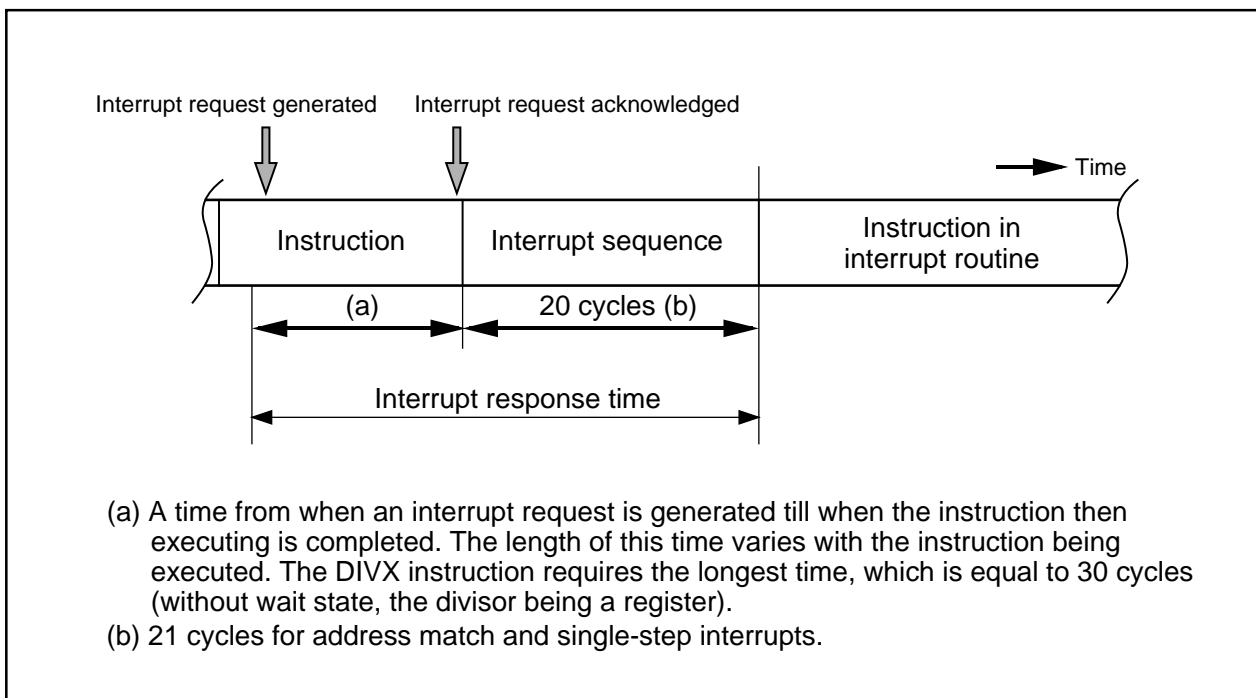

**Figure 10.5 Interrupt Response Time**

### • Variation of IPL when Interrupt Request is Accepted

When a maskable interrupt request is accepted, the interrupt priority level of the accepted interrupt is set in the IPL.

When a software interrupt or special interrupt request is accepted, one of the interrupt priority levels listed in Table 10.5 is set in the IPL. Shown in Table 10.5 are the IPL values of software and special interrupts when they are accepted.

**Table 10.5 IPL Level That Is Set to IPL When A Software or Special Interrupt Is Accepted**

Interrupt factor	Level that is set to IPL
Watchdog timer, oscillation stop detection, voltage detection	7
Software, address match, single-step	Not changed

• **Saving Registers**

In the interrupt sequence, the FLG register and PC are saved to the stack.

At this time, the 4 high-order bits in the PC and the 4 high-order (IPL) and 8 low-order bits in the FLG register, 16 bits in total, are saved to the stack first. Next, the 16 low-order bits in the PC are saved. Figure 10.6 shows the stack status before and after an interrupt request is accepted.

The other necessary registers must be saved in a program at the beginning of the interrupt routine. The PUSHM instruction can save several registers in the register bank being currently used<sup>(1)</sup> with a single instruction.

NOTES:

1. Selectable from registers R0, R1, R2, R3, A0, A1, SB, and FB.

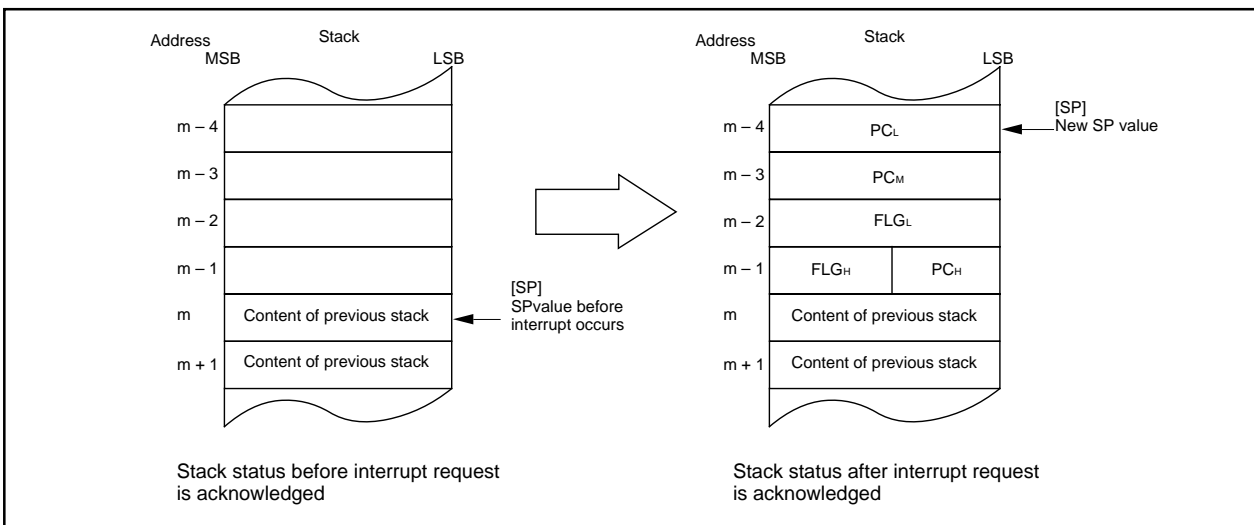
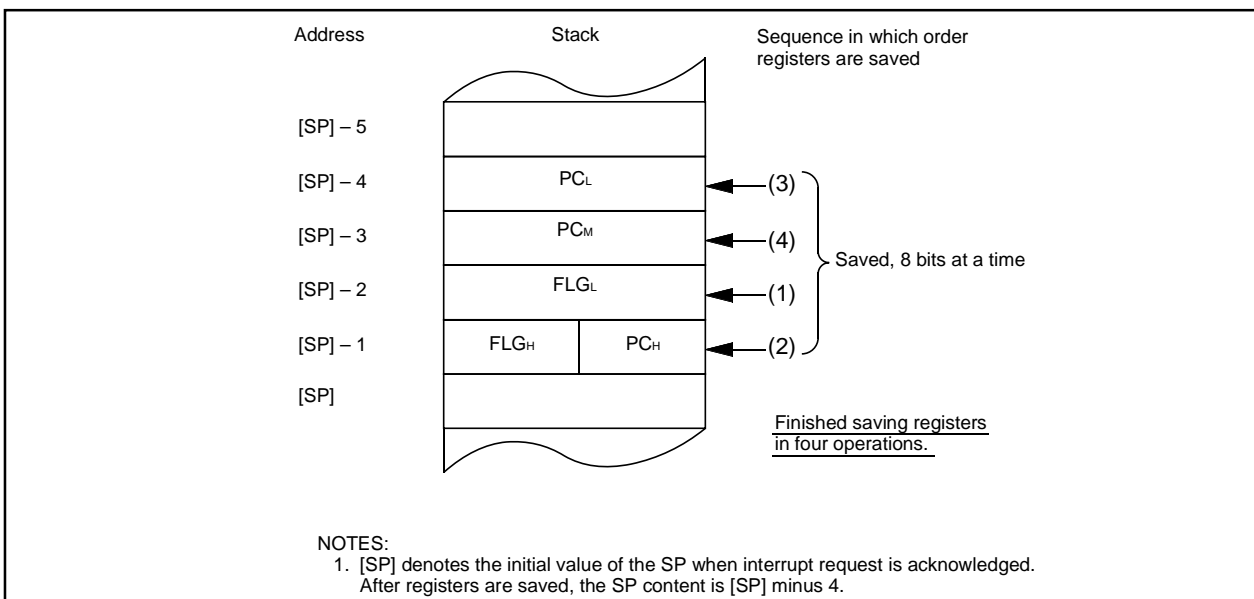

**Figure 10.6 Stack Status Before and After Acceptance of Interrupt Request**

The registers are saved in four steps, 8 bits at a time. Figure 10.7 shows the operation of the saving registers.

NOTES:

1. When any INT instruction in software numbers 32 to 63 has been executed, this is the SP indicated by the U flag. Otherwise, it is the ISP.



- NOTES:
1. [SP] denotes the initial value of the SP when interrupt request is acknowledged. After registers are saved, the SP content is [SP] minus 4.

**Figure 10.7 Operation of Saving Register**

- **Returning from an Interrupt Routine**

The FLG register and PC in the state in which they were immediately before entering the interrupt sequence are restored from the stack by executing the REIT instruction at the end of the interrupt routine. Thereafter the CPU returns to the program which was being executed before accepting the interrupt request.

Return the other registers saved by a program within the interrupt routine using the POPM or similar instruction before executing the REIT instruction.

- **Interrupt Priority**

If two or more interrupt requests are generated while executing one instruction, the interrupt request that has the highest priority is accepted.

For maskable interrupts (peripheral functions), any desired priority level can be selected using the ILVL2 to ILVL0 bits. However, if two or more maskable interrupts have the same priority level, their interrupt priority is resolved by hardware, with the highest priority interrupt accepted.

The watchdog timer and other special interrupts have their priority levels set in hardware. Figure 10.8 shows the Hardware Interrupt Priority.

Software interrupts are not affected by the interrupt priority. If an instruction is executed, control branches invariably to the interrupt routine.

Reset > WDT/Oscillation stop detection/Voltage detection > Peripheral function > Single step > Address match

**Figure 10.8 Hardware Interrupt Priority**

• **Interrupt Priority Resolution Circuit**

The interrupt priority resolution circuit is used to select the interrupt with the highest priority among those requested.

Figure 10.9 shows the Interrupts Priority Select Circuit.

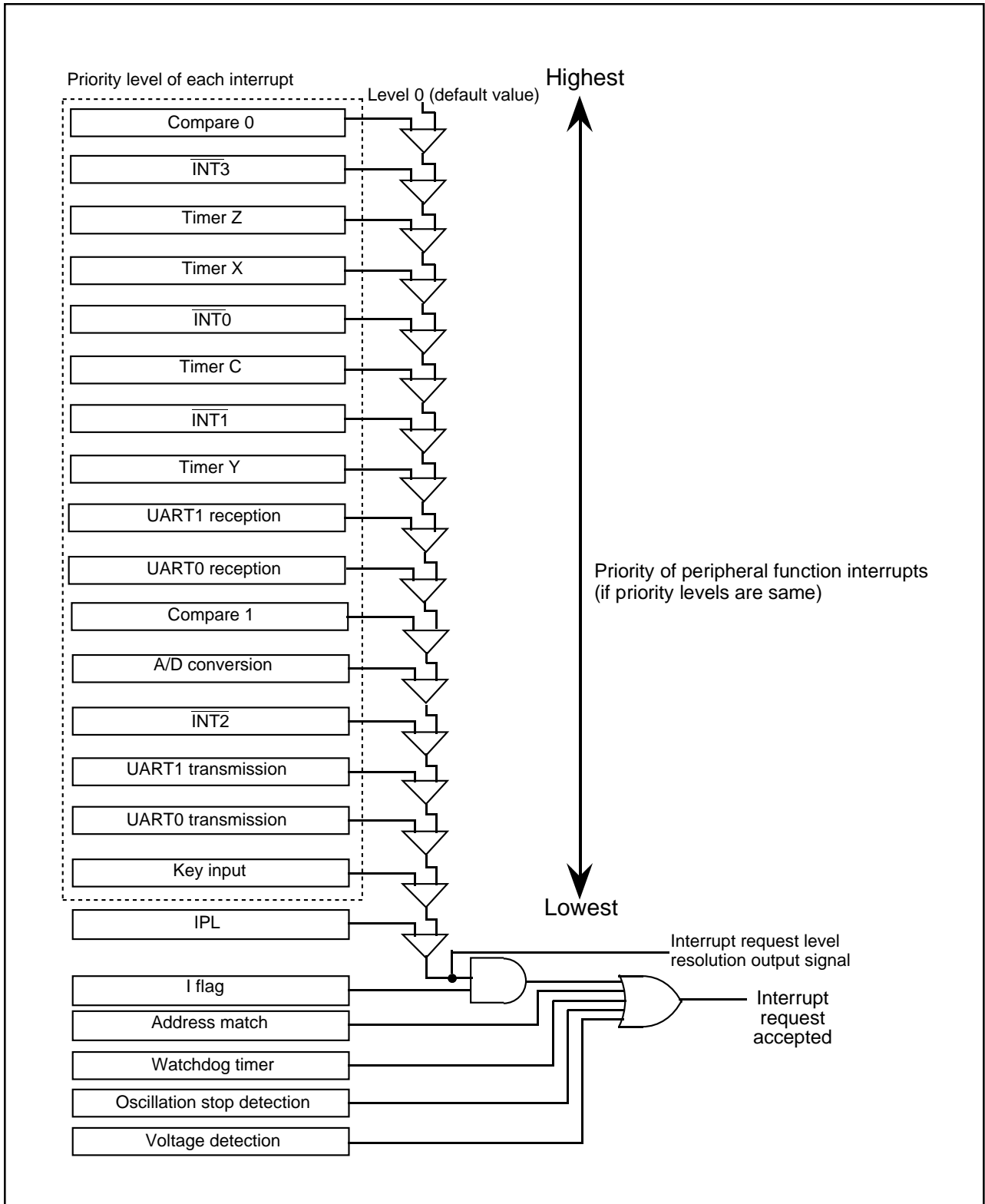

Figure 10.9 Interrupts Priority Select Circuit

## 10.2 INT Interrupt

### 10.2.1 INT0 Interrupt

INT0 interrupt is triggered by an INT0 input. When using INT0 interrupts, the INT0EN bit in the INTEN register must be set to “1” (enabling). The edge polarity is selected using the INT0PL bit in the INTEN register and the POL bit in the INTOIC register.

Inputs can be passed through a digital filter with three different sampling clocks.

The INT0 pin is shared with the external trigger input pin of Timer Z.

Figure 10.10 shows the INTEN and INTOF registers.

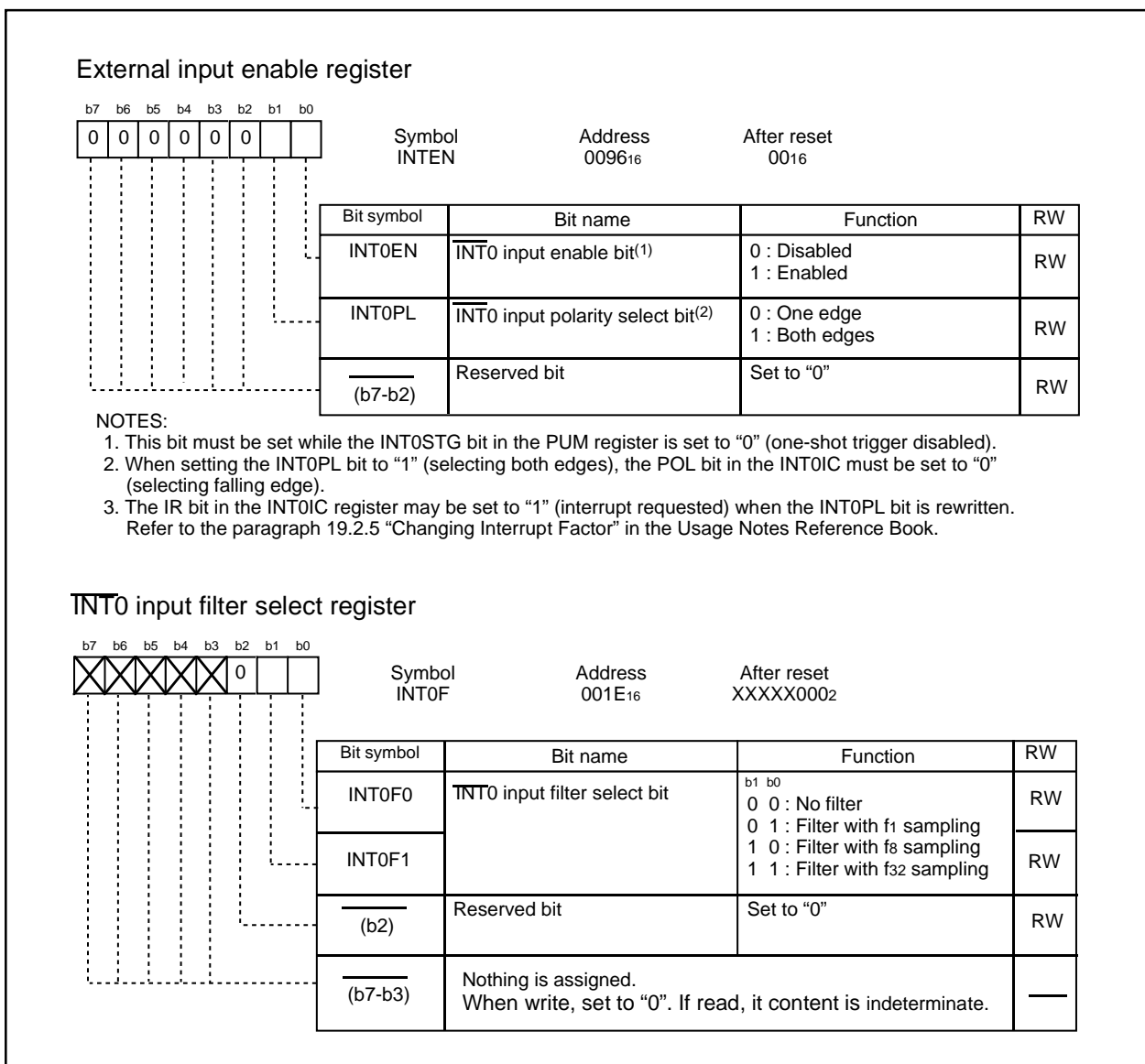
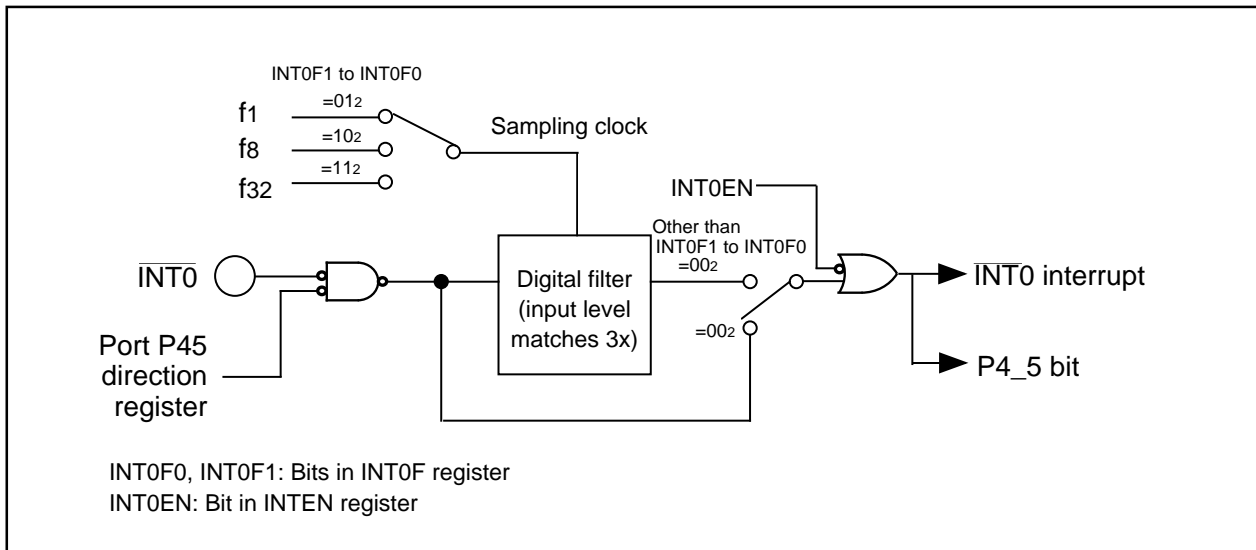

Figure 10.10 INTEN Register and INTOF Register

**10.2.2  $\overline{\text{INT0}}$  Input Filter**

The  $\overline{\text{INT0}}$  input has a digital filter which can be sampled by one of three sampling clocks. The sampling clock is selected using the INT0F1 to INT0F0 bits in the INT0F register. The IR bit in the INT0IC register is set to "1" (interrupt requested) when the sampled input level matches three times. When the INT0F1 to INT0F0 bits are set to "012", "102", or "112", the P4\_5 bit in the P4 register indicates the filtered value.

Figure 10.11 shows the  $\overline{\text{INT0}}$  input filter configuration. Figure 10.12 shows an operation example of  $\overline{\text{INT0}}$  input filter.



**Figure 10.11  $\overline{\text{INT0}}$  Input Filter**

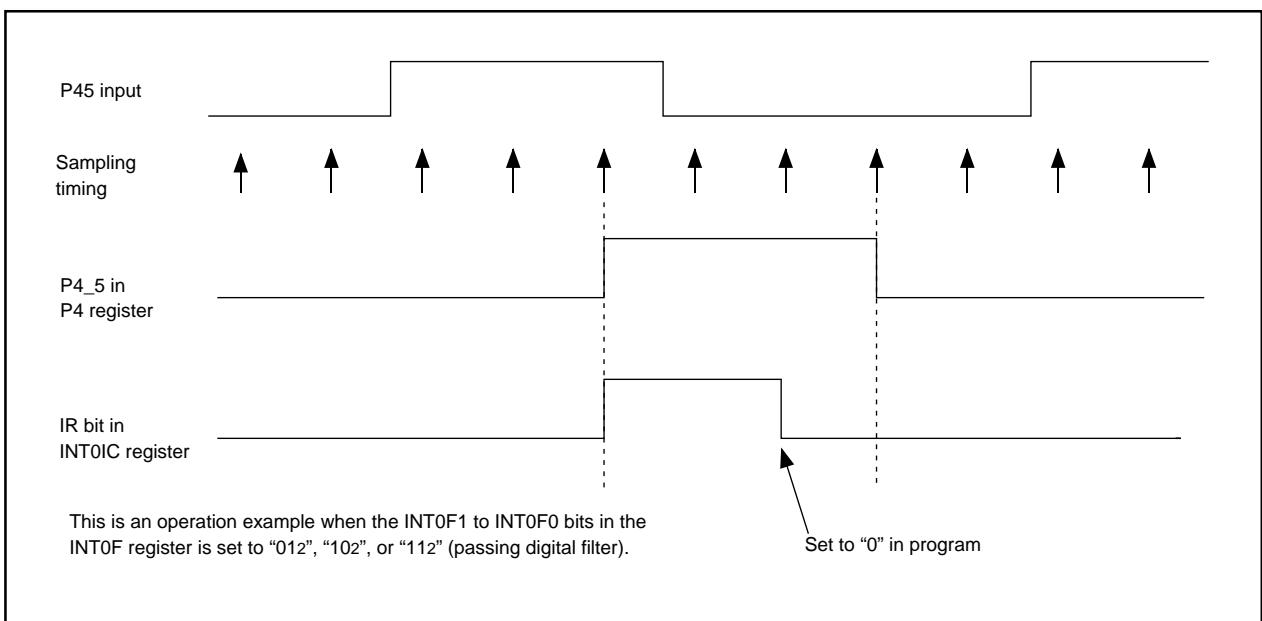

**Figure 10.12 Operation Example of  $\overline{\text{INT0}}$  Input Filter**



### 10.2.3 $\overline{\text{INT1}}$ Interrupt and $\overline{\text{INT2}}$ Interrupt

$\overline{\text{INT1}}$  interrupts are triggered by  $\overline{\text{INT1}}$  inputs. The edge polarity is selected with the R0EDG bit in the TXMR register. The  $\overline{\text{INT1}}$  pin is shared with the CNTR0 pin.

$\overline{\text{INT2}}$  interrupts are triggered by  $\overline{\text{INT2}}$  inputs. The edge polarity is selected with the R1EDG bit in the TYZMR register. The  $\overline{\text{INT2}}$  pin is shared with the CNTR1 pin.

Figure 10.13 shows the TXMR and TYZMR registers when using  $\overline{\text{INT1}}$  and  $\overline{\text{INT2}}$  interrupts.

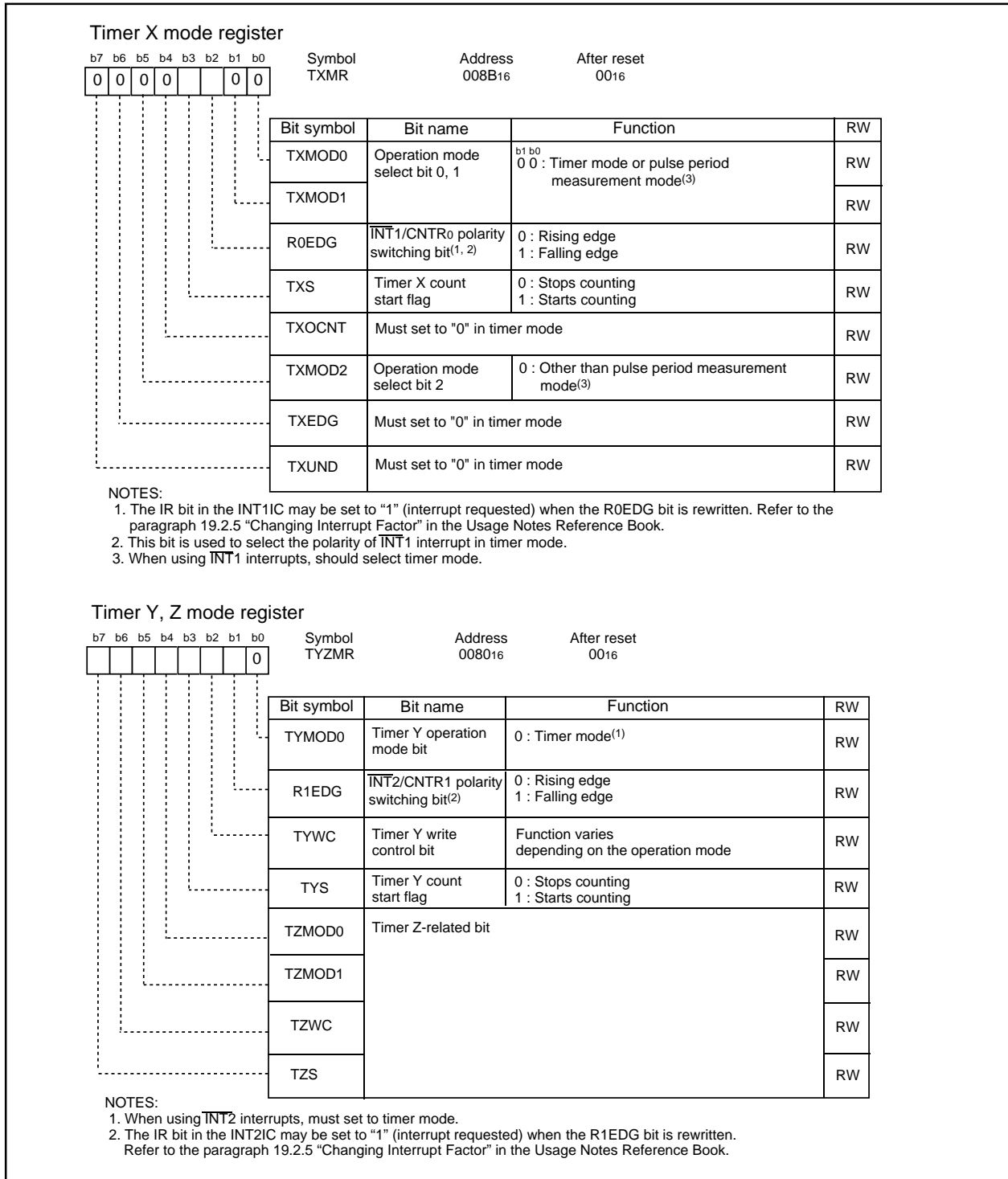

**Figure 10.13 TXMR Register and TYZMR Register when  $\overline{\text{INT1}}$  and  $\overline{\text{INT2}}$  Interrupt Used**

#### 10.2.4 $\overline{\text{INT3}}$ Interrupt

$\overline{\text{INT3}}$  interrupts are triggered by  $\overline{\text{INT3}}$  inputs. The TCC07 bit in the TCC0 register should be set to "0" ( $\overline{\text{INT3}}$ ). The  $\overline{\text{INT3}}$  input has a digital filter which can be sampled by one of three sampling clocks. The sampling clock is selected using the TCC11 to TCC10 bits in the TCC1 register. The IR bit in the INT3IC register is set to "1" (interrupt requested) when the sampled input level matches three times. The P3\_3 bit in the P3 register indicates the previous value before filtering regardless of values set in the TCC11 to TCC10 bits.

The  $\overline{\text{INT3}}$  pin is shared with the TCIN pin.

When setting the TCC07 bit to "1" (FRING128),  $\overline{\text{INT3}}$  interrupts are triggered by FRING128 clock. The IR bit in the INT3IC register is set to "1" (interrupt requested) every FRING128 clock cycle or every half FRING128 clock cycle.

Figure 10.14 shows the TCC0 and TCC1 registers.

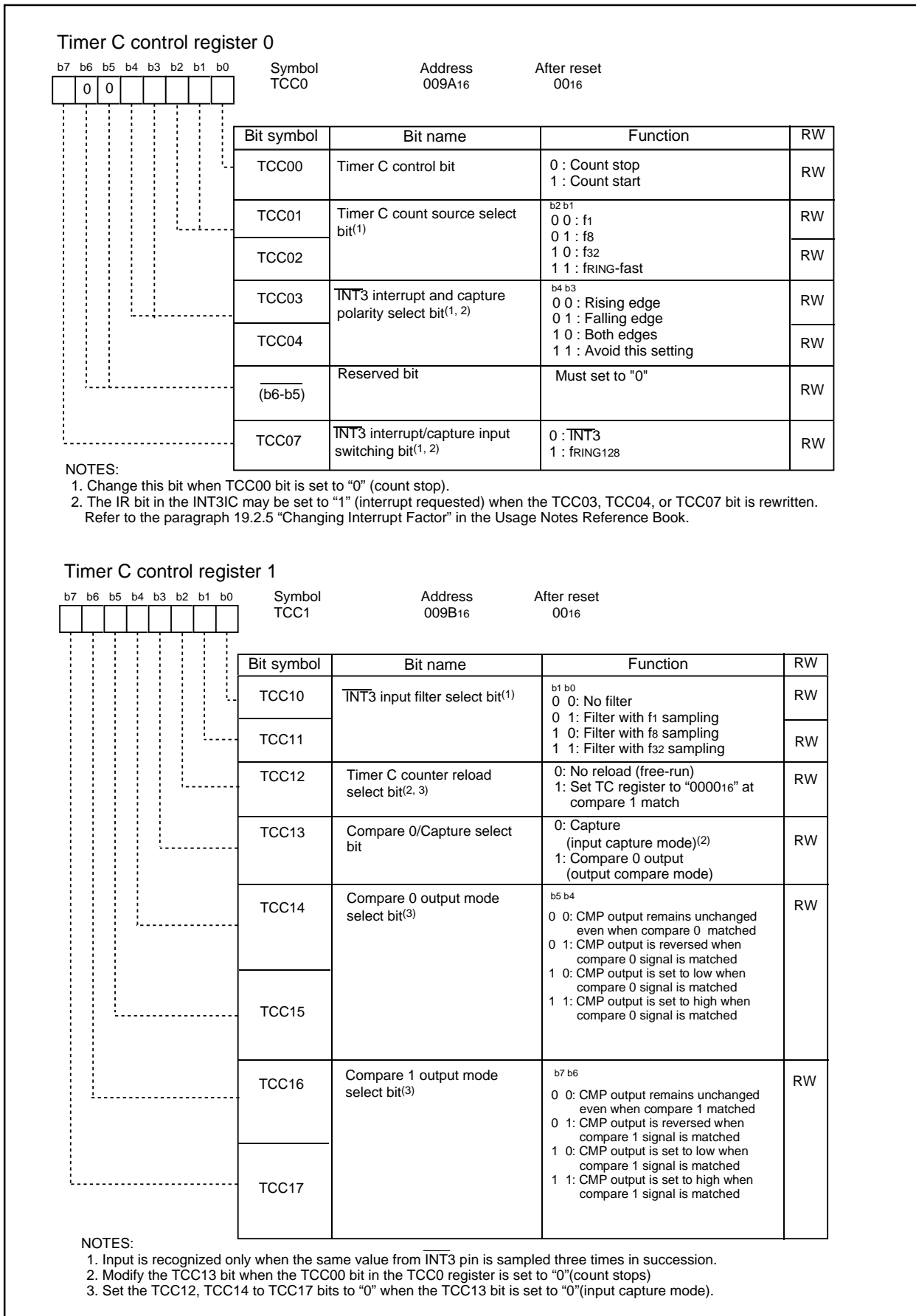

Figure 10.14 TCC0 Register and TCC1 Register

### 10.3 Key Input Interrupt

A key input interrupt is generated on an input edge of any of the  $\overline{K10}$  to  $\overline{K13}$  pins. Key input interrupts can be used as a key-on wakeup function to exit wait or stop mode.  $\overline{KLi}$  input can be enabled or disabled selecting with the  $KLiEN$  ( $i=0$  to 3) bit in the KIEN register. The edge polarity can be rising edge or falling edge selecting with the  $KLiPL$  bit in the KIEN register. Note, however, that while input on any  $\overline{KLi}$  pin which has had the  $KLiPL$  bit set to “0” (falling edge) is pulled low, inputs on all other pins of the port are not detected as interrupts. Similarly, while input on any  $\overline{KLi}$  pin which has had the  $KLiPL$  bit set to “1” (rising edge) is pulled high, inputs on all other pins of the port are not detected as interrupts.

Figure 10.15 shows a block diagram of the key input interrupt.

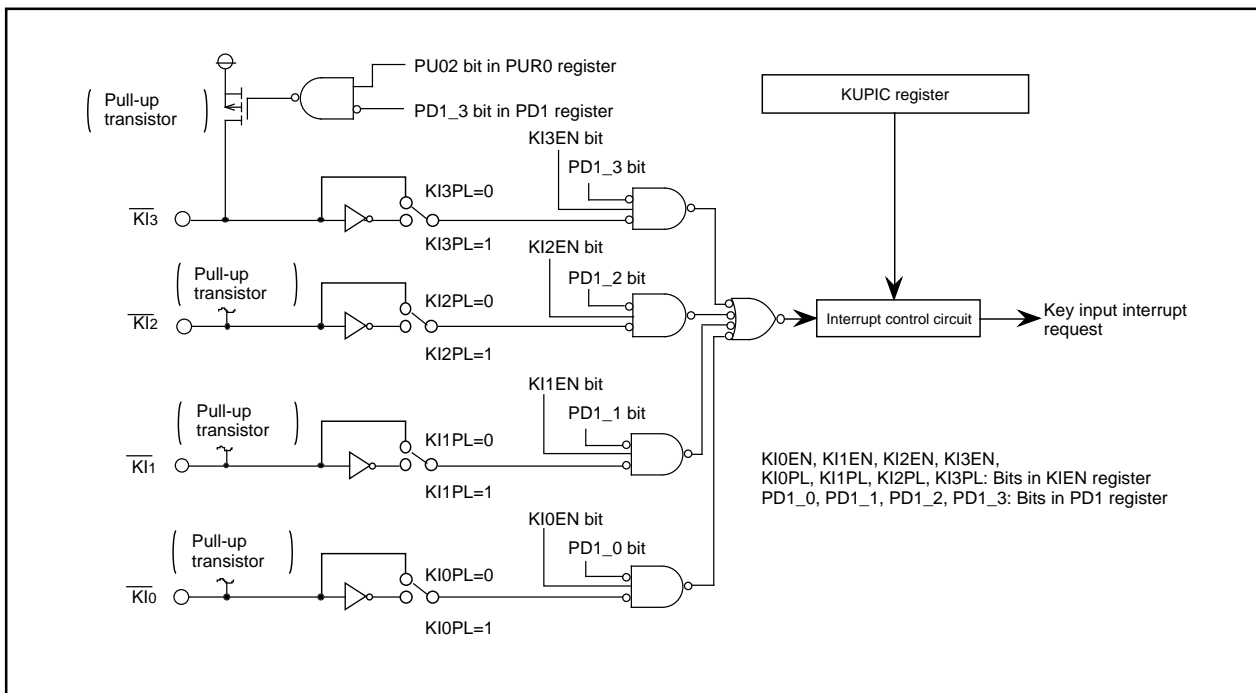

Figure 10.15 Key Input Interrupt

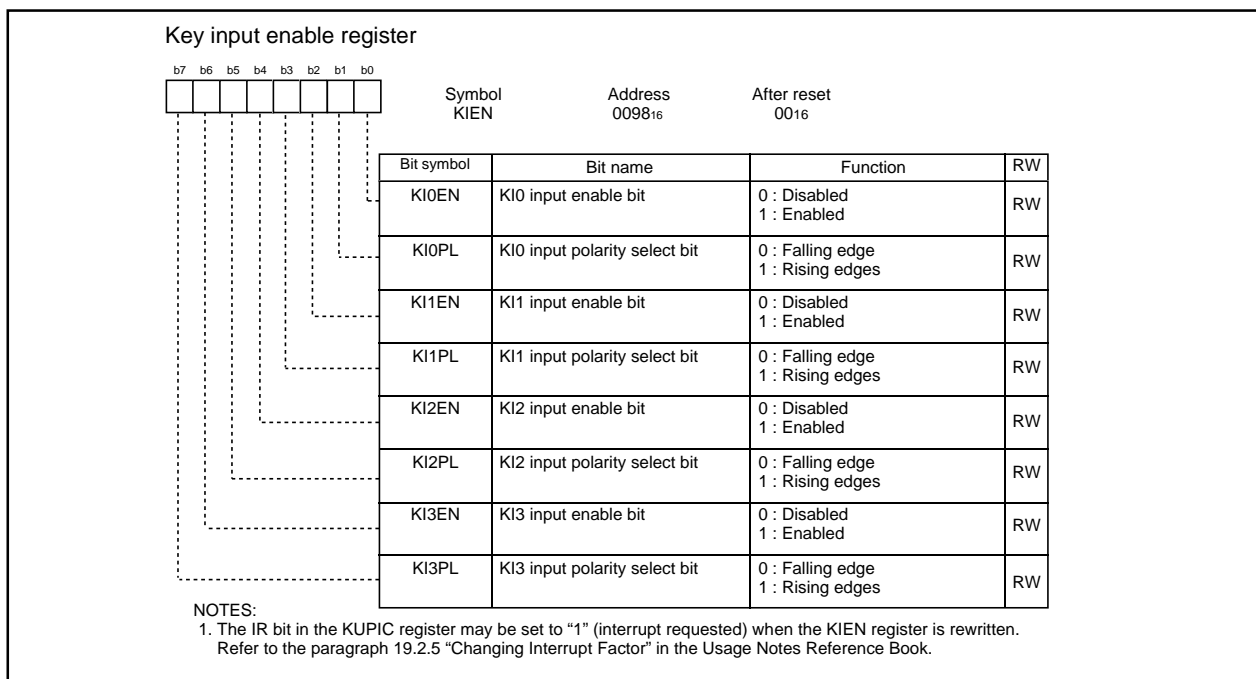

Figure 10.16 KIEN Register

## 10.4 Address Match Interrupt

An address match interrupt is generated immediately before executing the instruction at the address indicated by the RMADi register (i=0, 1). Set the start address of any instruction in the RMADi register. Use the AIER0 and AIER1 bits in the AIER register to enable or disable the interrupt. Note that the address match interrupt is unaffected by the I flag and IPL.

The value of the PC that is saved to the stack when an address match interrupt is acknowledged varies depending on the instruction at the address indicated by the RMAD i register (see the paragraph “register saving” for the value of the PC). Not appropriate return address is pushed on the stack. There are two ways to return from the address match interrupt as follows:

- Change the content of the stack and use a REIT instruction.
- Use an instruction such as POP to restore the stack as it was before an interrupt request was acknowledged. And then use a jump instruction.

Table 10.6 lists the value of the PC that is saved to the stack when an address match interrupt is acknowledged.

Figure 10.17 shows the AIER, and RMAD1 to RMAD0 registers.

**Table 10.6 Value of PC Saved to Stack when Address Match Interrupt Acknowledged**

Address indicated by RMADi register (i=0,1)	PC value saved <sup>(1)</sup>
<ul style="list-style-type: none"> <li>• 16-bit operation code instruction</li> <li>• Instruction shown below among 8-bit operation code instructions</li> </ul> ADD.B:S #IMM8,dest    SUB.B:S #IMM8,dest    AND.B:S #IMM8,dest OR.B:S #IMM8,dest    MOV.B:S #IMM8,dest    STZ.B:S #IMM8,dest STNZ.B:S #IMM8,dest    STZX.B:S #IMM81,#IMM82,dest CMP.B:S #IMM8,dest    PUSHM src            POPM dest JMPS #IMM8            JSRS #IMM8 MOV.B:S #IMM,dest (However, dest = A0 or A1)	Address indicated by RMADi register + 2
<ul style="list-style-type: none"> <li>• Instructions other than the above</li> </ul>	Address indicated by RMADi register + 1

NOTES:

1. See the paragraph “saving registers” for the PC value saved.

**Table 10.7 Relationship Between Address Match Interrupt Factors and Associated Registers**

Address match interrupt factors	Address match interrupt enable bit	Address match interrupt register
Address match interrupt 0	AIER0	RMAD0
Address match interrupt 1	AIER1	RMAD1

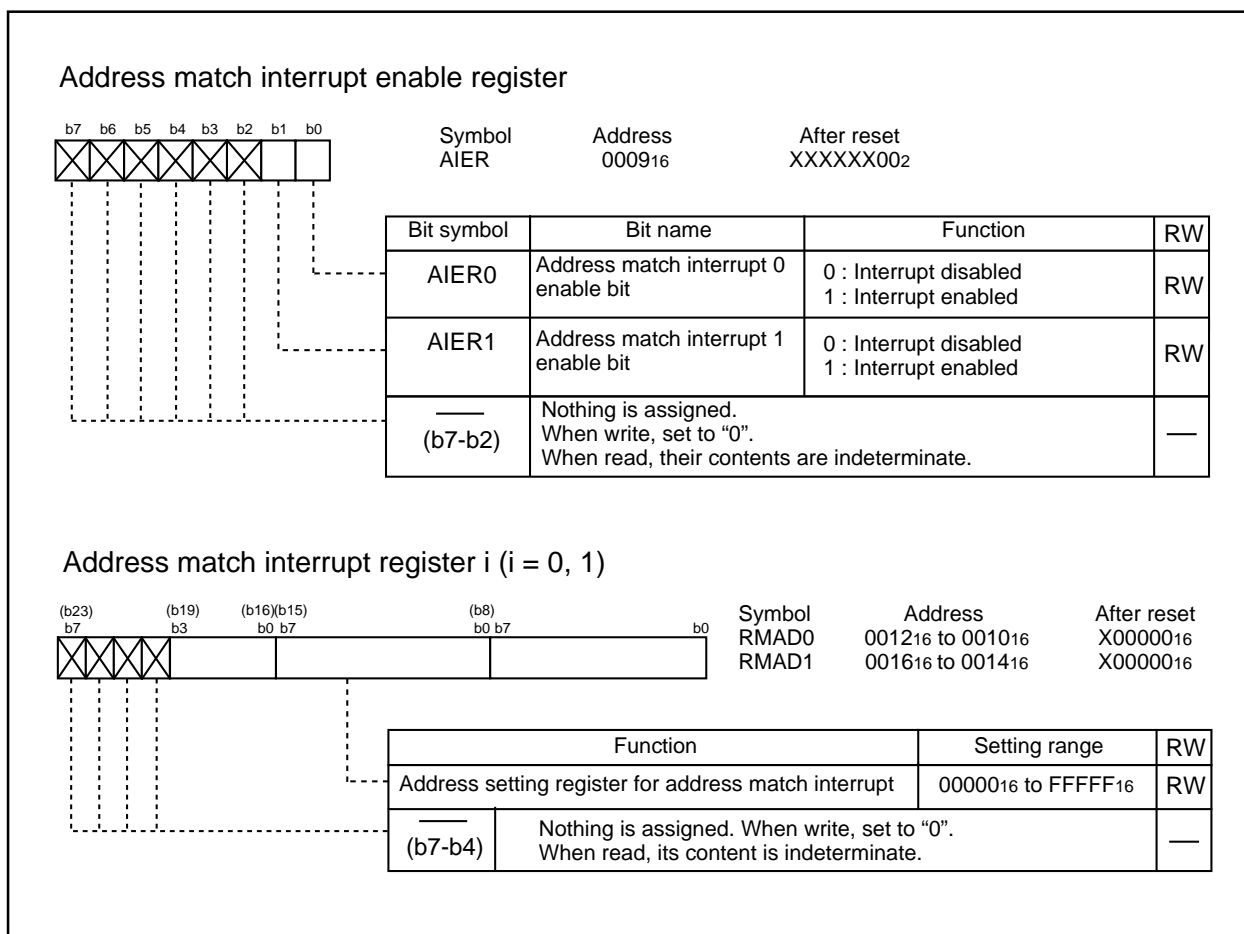

Figure 10.17 AIER Register and RMAD0 to RMAD1 Registers

## 11. Watchdog Timer

The watchdog timer is the function of detecting when the program is out of control. Therefore, we recommend using the watchdog timer to improve reliability of a system. The watchdog timer contains a 15-bit counter which counts down the clock derived by dividing the CPU clock using the prescaler. Whether to generate a watchdog timer interrupt request or apply a watchdog timer reset as an operation to be performed when the watchdog timer underflows after reaching the terminal count can be selected using the PM12 bit in the PM1 register. The PM12 bit can only be set to "1" (reset). Once this bit is set to "1", it cannot be set to "0" (watchdog timer interrupt) in a program. Refer to Section 5.3, "Watchdog Timer Reset" for details.

The divide-by-N value for the prescaler can be chosen to be 16 or 128 with the WDC7 bit in the WDC register. The period of watchdog timer can be calculated as given below. The period of watchdog timer is, however, subject to an error due to the prescaler.

$$\text{Watchdog timer period} = \frac{\text{Prescaler dividing (16 or 128)} \times \text{Watchdog timer count (32768)}}{\text{CPU clock}}$$

For example, when CPU clock = 16 MHz and the divide-by-N value for the prescaler = 16, the watchdog timer period is approx. 32.8 ms.

Note that the watchdog timer and the prescaler both are inactive after reset, so that the watchdog timer is activated to start counting by writing to the WDTS register. After that, the watchdog timer is initialized by writing to the WDTR register and the counting continues.

In stop mode and wait mode, the watchdog timer and prescaler are stopped. Counting is resumed from the held value when the modes or state are released.

Figure 11.1 shows the block diagram of the watchdog timer. Figure 11.2 shows the watchdog timer-related registers.

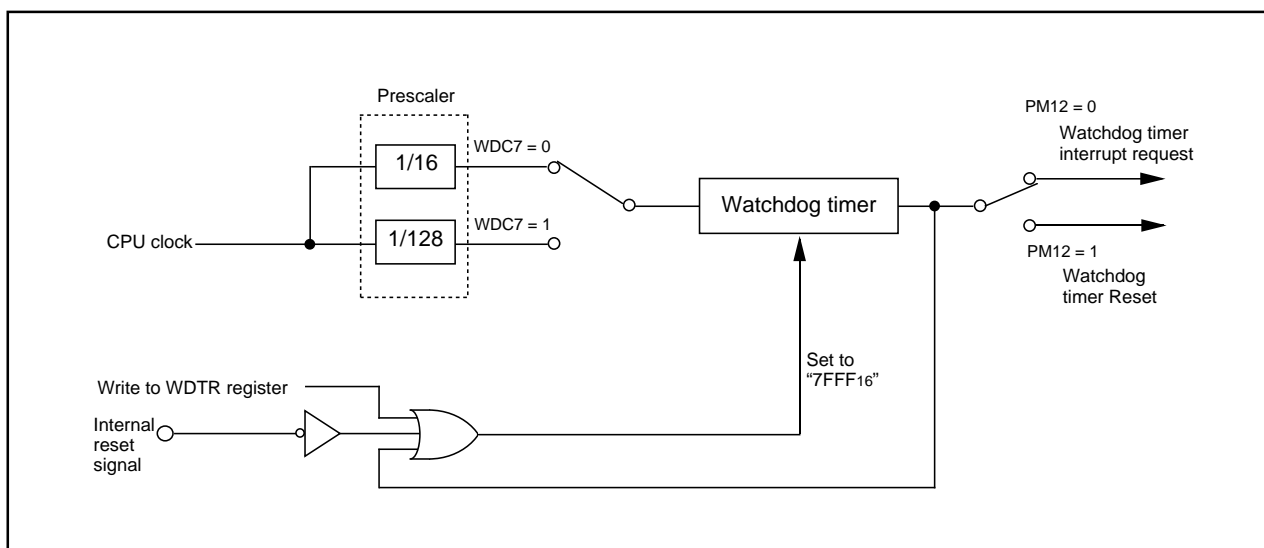

Figure 11.1 Watchdog Timer Block Diagram

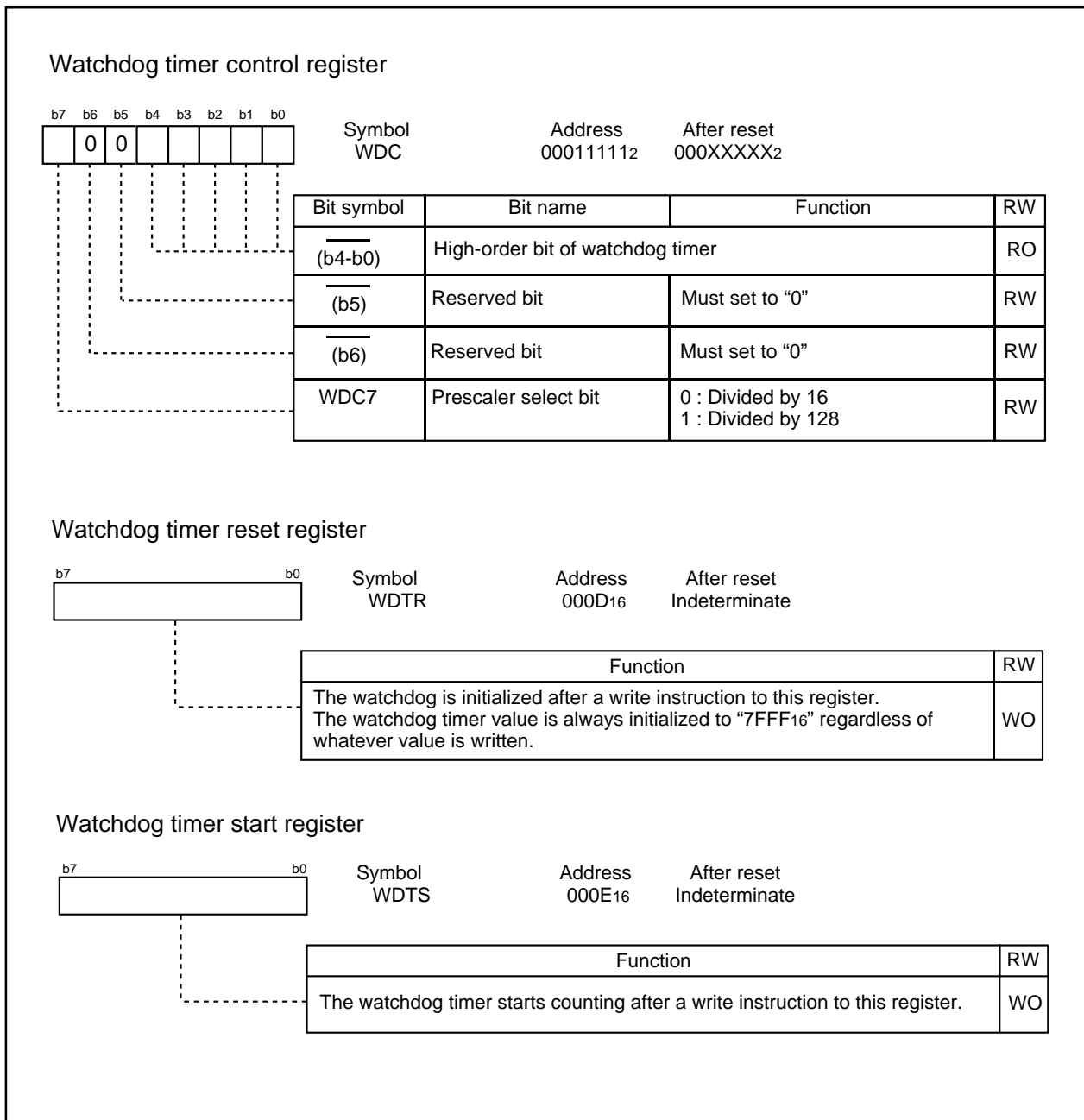

Figure 11.2 WDC Register, WDTR Register, and WDTS Register



## 12. Timers

The microcomputer has three 8-bit timers and one 16-bit timer. The three 8-bit timers are Timer X, Timer Y, and Timer Z and each one has an 8-bit prescaler. The 16-bit timer is Timer C and has input capture and output compare. All these timers function independently. The count source for each timer is the operating clock that regulates the timing of timer operations such as counting and reloading.

Table 12.1 lists functional comparison.

**Table 12.1 Functional Comparison**

Item	Timer X	Timer Y	Timer Z	Timer C	
Configuration	8-bit timer with 8-bit prescaler	8-bit timer with 8-bit prescaler	8-bit timer with 8-bit prescaler	16-bit free-run timer	
Count	Down	Down	Down	Up	
Count source	<ul style="list-style-type: none"> <li>•f1</li> <li>•f2</li> <li>•f8</li> <li>•f32</li> </ul>	<ul style="list-style-type: none"> <li>•f1</li> <li>•f8</li> <li>•fRING</li> <li>•Input from CNTR1 pin</li> </ul>	<ul style="list-style-type: none"> <li>•f1</li> <li>•f2</li> <li>•f8</li> <li>•Timer Y underflow</li> </ul>	<ul style="list-style-type: none"> <li>•f1</li> <li>•f8</li> <li>•f32</li> <li>•fRING-fast</li> </ul>	
Function	Timer mode	provided	provided	provided	not provided
	Pulse output mode	provided	not provided	not provided	not provided
	Event counter mode	provided	provided <sup>(1)</sup>	not provided	not provided
	Pulse width measurement mode	provided	not provided	not provided	not provided
	Pulse period measurement mode	provided	not provided	not provided	not provided
	Programmable waveform generation mode	not provided	provided	provided	not provided
	Programmable one-shot generation mode	not provided	not provided	provided	not provided
	Programmable wait one-shot generation mode	not provided	not provided	provided	not provided
	Input capture mode	not provided	not provided	not provided	provided
	Output compare mode	not provided	not provided	not provided	provided
Input pin	CNTR0	CNTR1	$\overline{\text{INT}}_0$	TCIN	
Output pin	CNTR0 $\overline{\text{CNTR}}_0$	CNTR1	TZOUT	CMP00 to CMP02 CMP10 to CMP12	
Related interrupt	Timer X int $\overline{\text{INT}}_1$ int	Timer Y int $\overline{\text{INT}}_2$ int	Timer Z int $\overline{\text{INT}}_0$ int	Timer C int $\overline{\text{INT}}_3$ int compare 0 int compare 1 int	
Timer stop	provided	provided	provided	provided	

**NOTES:**

1. Select the input from the CNTR1 pin as a count source of timer mode.

### 12.1 Timer X

The Timer X is an 8-bit timer with an 8-bit prescaler. Figure 12.1 shows the block diagram of Timer X. Figures 12.2 and 12.3 show the Timer X-related registers.

The Timer X has five operation modes listed as follows:

- Timer mode: The timer counts an internal count source.
- Pulse output mode: The timer counts an internal count source and outputs the pulses whose polarity is inverted at the timer the timer underflows.
- Event counter mode: The timer counts external pulses.
- Pulse width measurement mode: The timer measures an external pulse's pulse width.
- Pulse period measurement mode: The timer measures an external pulse's period.

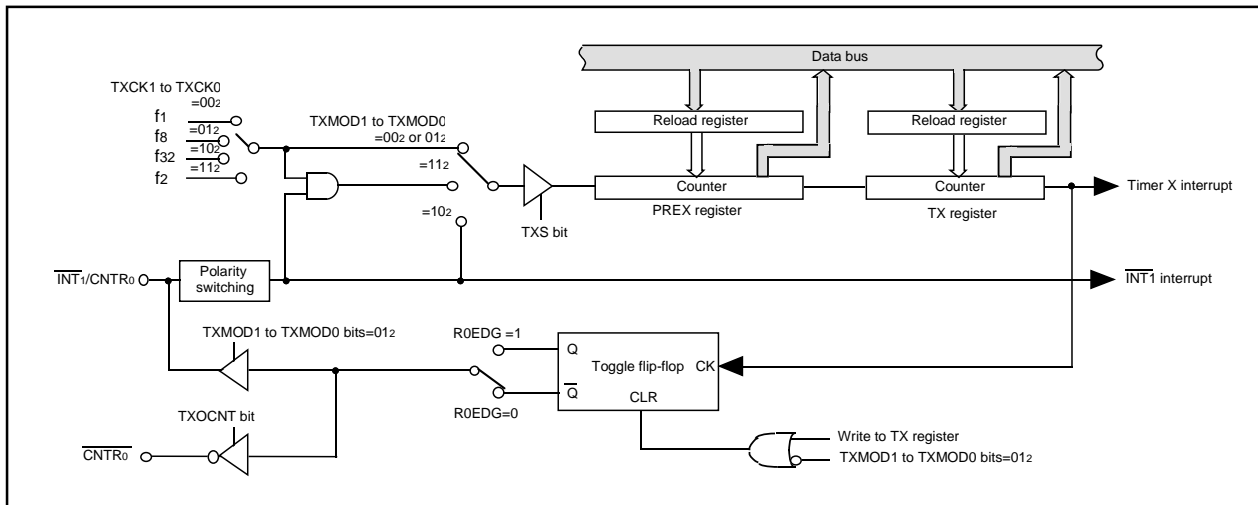

Figure 12.1 Timer X Block Diagram

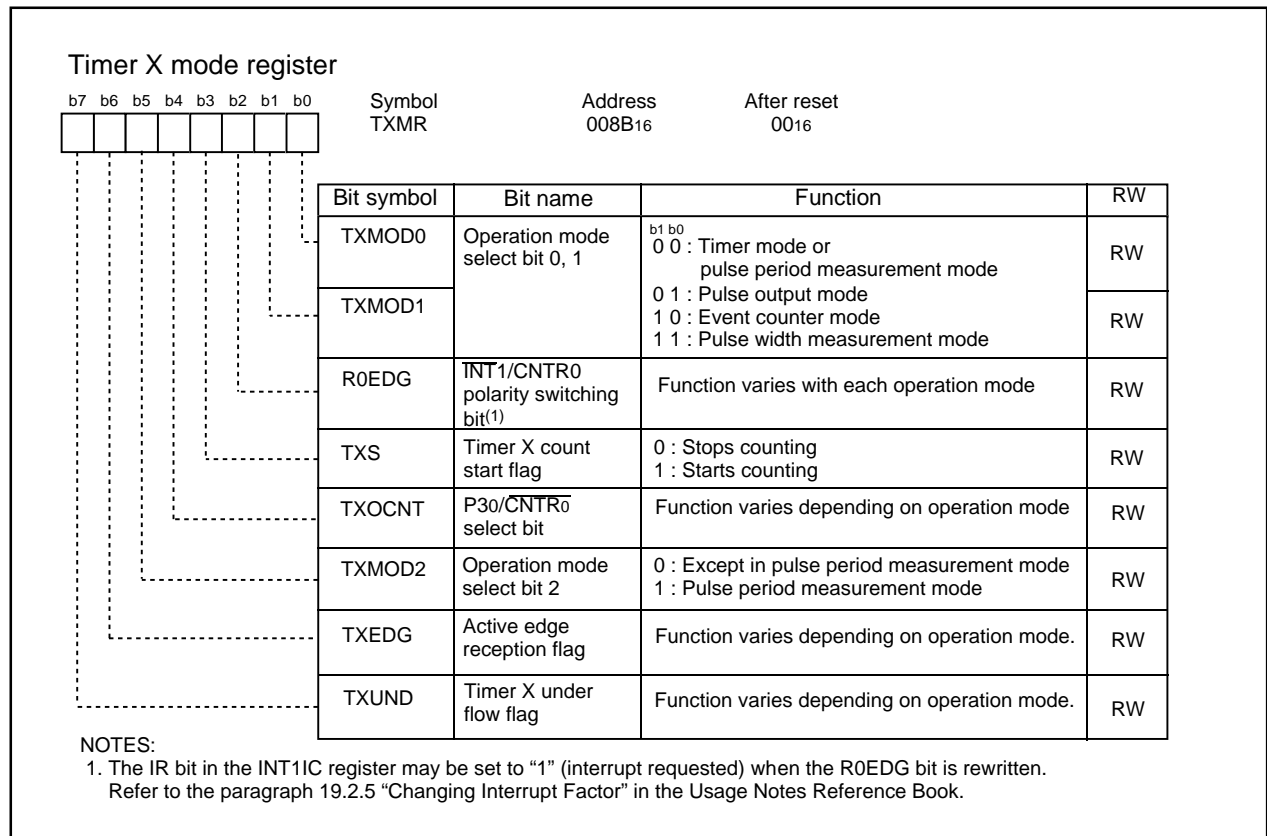
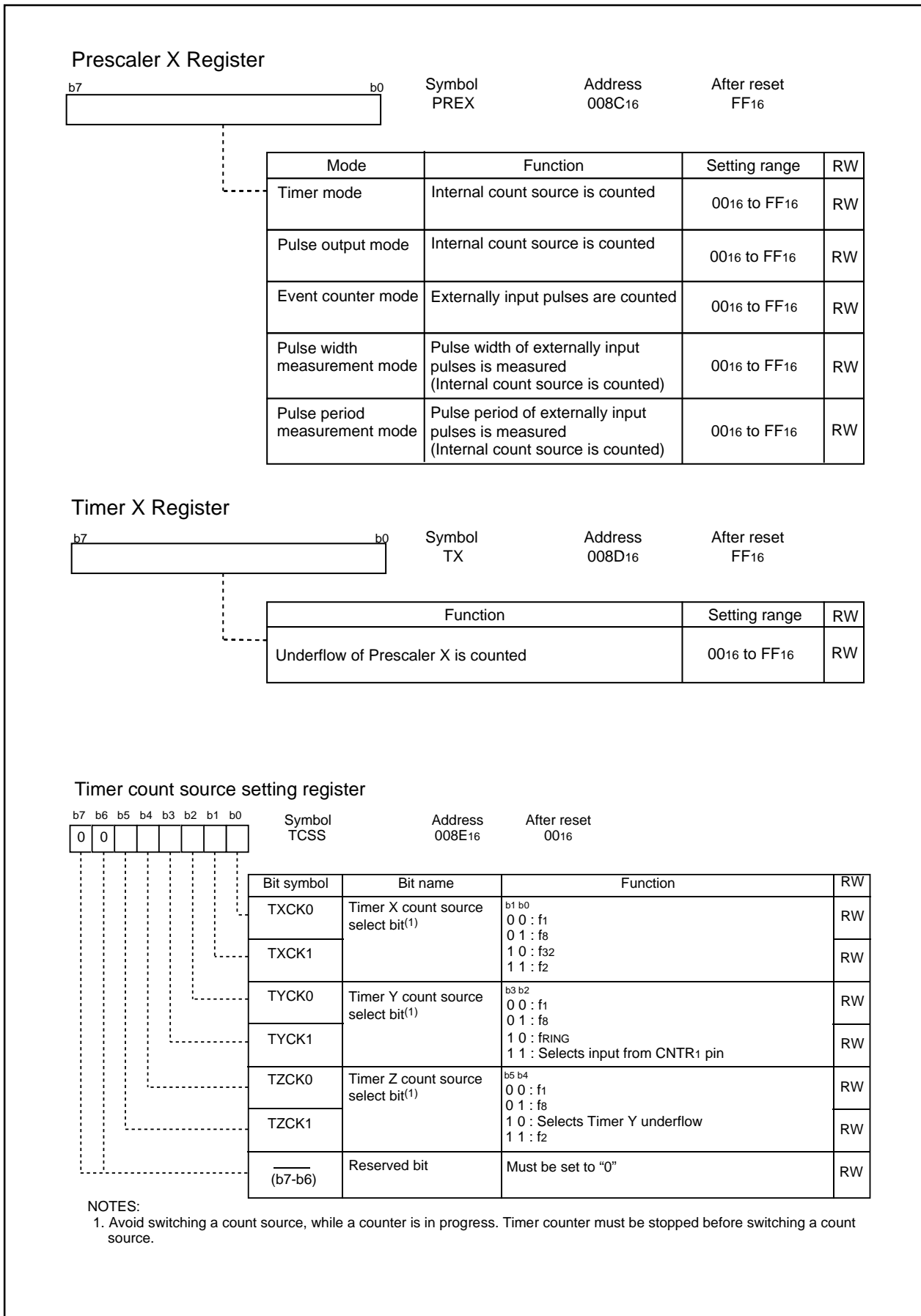

Figure 12.2 TXMR Register



**Figure 12.3 PREX Register, TX Register, and TCSS Register**

### 12.1.1 Timer Mode

In this mode, the timer counts an internally generated count source (See “Table 12.2 Timer Mode Specifications”). Figure 12.4 shows the TXMR register in timer mode.

**Table 12.2 Timer Mode Specifications**

Item	Specification
Count source	f1, f2, f8, f32
Count operation	<ul style="list-style-type: none"> <li>Down-count</li> <li>When the timer underflows, the contents in the reload register is reloaded and the count is continued.</li> </ul>
Divide ratio	$1/(n+1)(m+1)$ n: set value of PREX register, m: set value of TX register
Count start condition	Write “1” (count start) to TXS bit in TXMR register
Count stop condition	Write “0” (count stop) to TXS bit in TXMR register
Interrupt request generation timing	When Timer X underflows [Timer X interruption]
INT1/CNTR0 pin function	Programmable I/O port, or INT1 interrupt input
CNTR0 pin function	Programmable I/O port
Read from timer	Count value can be read by reading TX register Same applies to PREX register.
Write to timer	Value written to TX register is written to both reload register and counter. Same applies to PREX register.

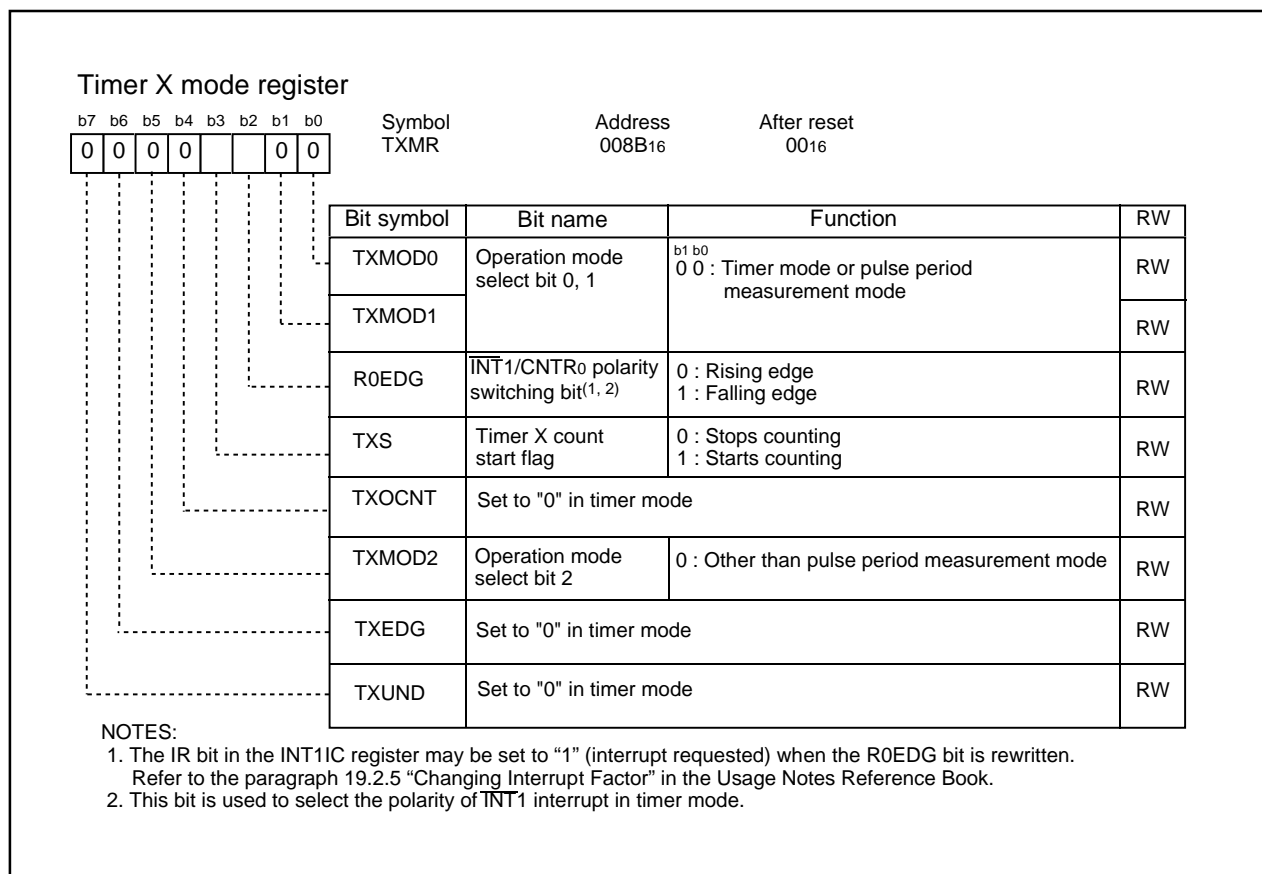

**Figure 12.4 TXMR Register in Timer Mode**

### 12.1.2 Pulse Output Mode

In this mode, the timer counts an internally generated count source, and outputs from the CNTR0 pin a pulse whose polarity is inverted each time the timer underflows (See "Table 12.3 Pulse Output mode Specifications"). Figure 12.5 shows TXMR register in pulse output mode.

**Table 12.3 Pulse Output Mode Specifications**

Item	Specification
Count source	f1, f2, f8, f32
Count operation	<ul style="list-style-type: none"> <li>Down-count</li> <li>When the timer underflows, the contents in the reload register is reloaded and the count is continued.</li> </ul>
Divide ratio	$1/(n+1)(m+1)$ n: set value of PREX register, m: set value of TX register
Count start condition	Write "1" (count start) to TXS bit in TXMR register
Count stop condition	Write "0" (count stop) to TXS bit in TXMR register
Interrupt request generation timing	<ul style="list-style-type: none"> <li>When Timer X underflows [Timer X interruption]</li> </ul>
INT1/CNTR0 pin function	Pulse output
CNTR0 pin function	Programmable I/O port or inverted output of CNTR0
Read from timer	Count value can be read by reading TX register. Same applies to PREX register.
Write to timer	Value written to TX register is written to both reload register and counter. Same applies to PREX register.
Select function	<ul style="list-style-type: none"> <li>INT1/CNTR0 polarity switching function Polarity level at starting of pulse output can be selected with R0EDG bit<sup>(1)</sup></li> <li>Inverted pulse output function The inverted pulse of CNTR0 output polarity can be output from the CNTR0 pin (selected by the TXOCNT bit)</li> </ul>

**NOTES:**

- The level of the output pulse becomes the level when the pulse output starts when the TX register is written to.

Timer X mode register		Symbol	Address	After reset							
b7	b6	b5	b4	b3	b2	b1	b0	TXMR	008B <sub>16</sub>	00 <sub>16</sub>	
0	0	0				0	1				
								Bit symbol	Bit name	Function	RW
								TXMOD0	Operation mode select bit 0, 1	b1 b0 0 1 : Pulse output mode	RW
								TXMOD1			RW
								R0EDG	INT1/CNTR0 polarity switching bit <sup>(1)</sup>	0: CNTR0 output starts at "H" 1: CNTR0 output starts at "L"	RW
								TXS	Timer X count start flag	0 : Stops counting 1 : Starts counting	RW
								TXOCNT	P30/ $\overline{\text{CNTR0}}$ select bit	0 : Port P30 1 : $\overline{\text{CNTR0}}$ output	RW
								TXMOD2	Must set to "0" in pulse output mode		RW
								TXEDG	Must set to "0" in pulse output mode		RW
								TXUND	Must set to "0" in pulse output mode		RW

**NOTES:**

- The IR bit in the INT1IC register may be set to "1" (interrupt requested) when the R0EDG bit is rewritten. Refer to the paragraph 19.2.5 "Changing Interrupt Factor" in the Usage Notes Reference Book.

**Figure 12.5 TXMR Register in Pulse Output Mode**

### 12.1.3 Event Counter Mode

In this mode, the timer counts an external signal fed to  $\overline{\text{INT1/CNTR0}}$  pin (See "Table 12.4 Event Counter Mode Specifications"). Figure 12.6 shows TXMR register in event counter mode.

**Table 12.4 Event Counter Mode Specifications**

Item	Specification
Count source	External signals fed to CNTR0 pin (Active edge is selected by program)
Count operation	<ul style="list-style-type: none"> <li>Down count</li> <li>When the timer underflows, the contents in the reload register is reloaded and the count is continued.</li> </ul>
Divide ratio	$1/(n+1)(m+1)$ n: set value of PREX register, m: set value of TX register
Count start condition	Write "1" (count start) to TXS bit in TXMR register
Count stop condition	Write "0" (count stop) to TXS bit in TXMR register
Interrupt request generation timing	<ul style="list-style-type: none"> <li>When Timer X underflows [Timer X interrupt]</li> </ul>
$\overline{\text{INT1/CNTR0}}$ pin function	Count source input ( $\overline{\text{INT1}}$ interrupt input)
$\overline{\text{CNTR0}}$ pin function	Programmable I/O port
Read from timer	Count value can be read by reading TX register Same applies to PREX register.
Write to timer	Value written to TX register is written to both reload register and counter. Same applies to PREX register.
Select function	<ul style="list-style-type: none"> <li><math>\overline{\text{INT1/CNTR0}}</math> polarity switching function</li> </ul> Active edge of count source can be selected with R0EDG.

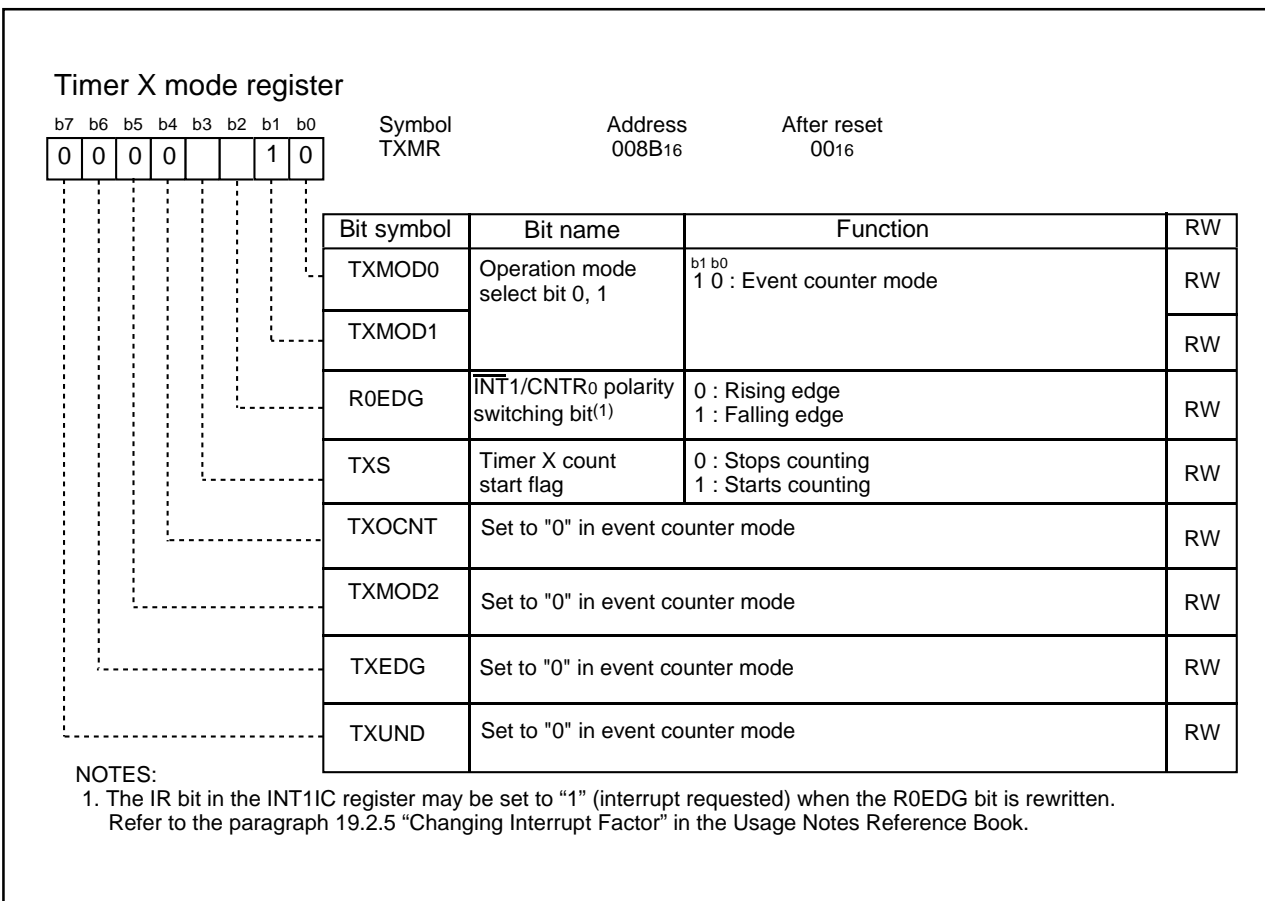

**Figure 12.6 TXMR Register in Event Counter Mode**

### 12.1.4 Pulse Width Measurement Mode

In this mode, the timer measures the pulse width of an external signal fed to  $\overline{\text{INT1}}/\text{CNTR0}$  pin (See "Table 12.5 Pulse Width Measurement Mode Specifications"). Figure 12.7 shows the TXMR register in pulse width measurement mode. Figure 12.8 shows an operation example in pulse width measurement mode.

**Table 12.5 Pulse Width Measurement Mode Specifications**

Item	Specification
Count source	f1, f2, f8, f32
Count operation	<ul style="list-style-type: none"> <li>Down-count</li> <li>Continuously counts the selected signal only when the measurement pulse is "H" level, or conversely only "L" level.</li> <li>When the timer underflows, the contents in the reload register is reloaded and the count is continued.</li> </ul>
Count start condition	Write "1" (count start) to TXS bit in TXMR register
Count stop condition	Write "0" (count stop) to TXS bit in TXMR register
Interrupt request generation timing	<ul style="list-style-type: none"> <li>When Timer X underflows [Timer X interruption]</li> <li>Rising or falling of CNTR0 input (end of measurement period) [<math>\overline{\text{INT1}}</math> interrupt]</li> </ul>
$\overline{\text{INT1}}/\text{CNTR0}$ pin function	Measurement pulse input
CNTR0 pin function	Programmable I/O port
Read from timer	Count value can be read by reading TX register Same applies to PREX register.
Write to timer	Value written to TX register is written to both reload register and counter. Same applies to PREX register.
Select function	<ul style="list-style-type: none"> <li><math>\overline{\text{INT1}}/\text{CNTR0}</math> polarity switching function</li> </ul> "H" or "L" level duration can be selected with R0EDG bit as the input pulse measurement

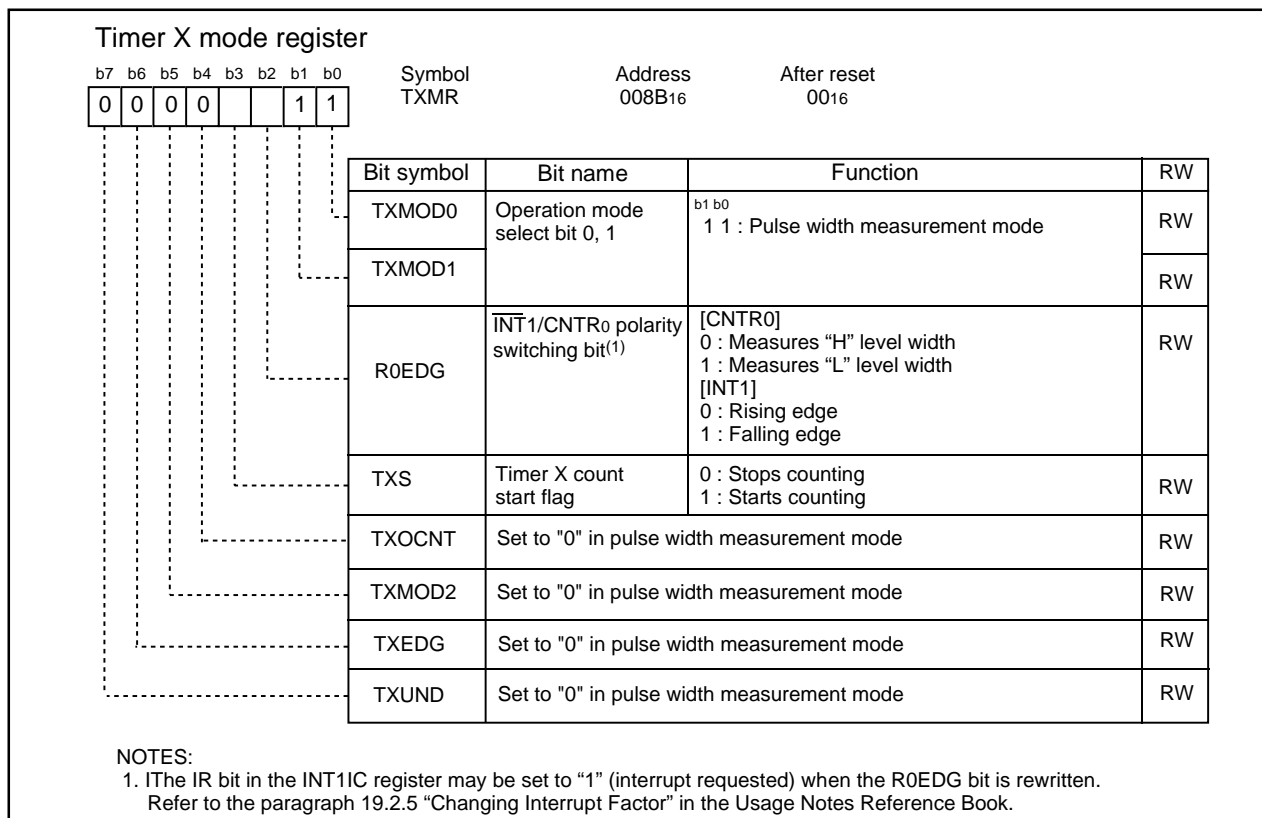

**Figure 12.7 TXMR Register in Pulse Width Measurement Mode**

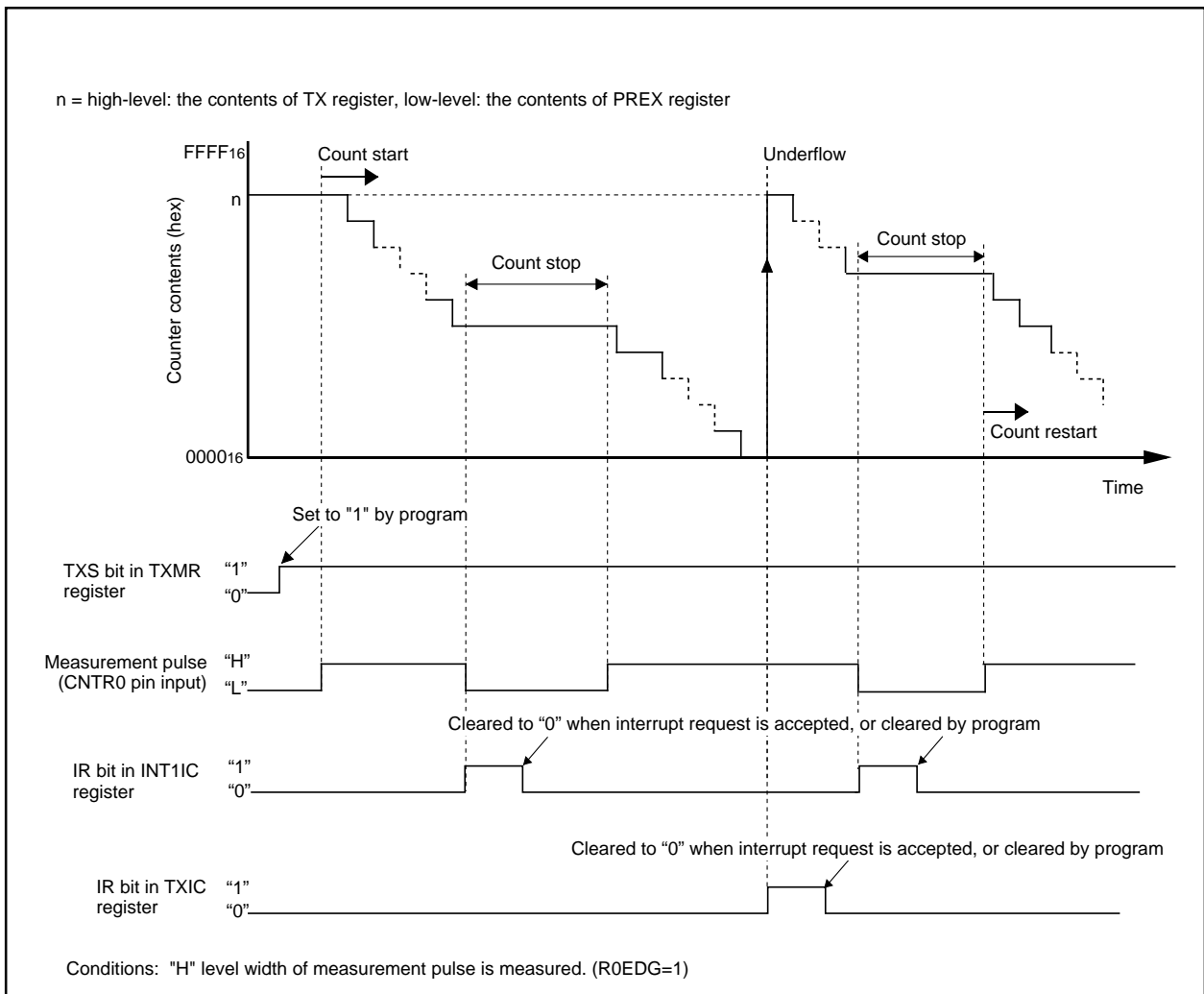

**Figure 12.8 Operation Example in Pulse Width Measurement Mode**



### 12.1.5 Pulse Period Measurement Mode

In this mode, the timer measures the pulse period of an external signal fed to INT1/CNTR0 pin (See "Table 12.6 Pulse Period Measurement Mode Specifications"). Figure 12.9 shows the TXMR register in pulse period measurement mode. Figure 12.10 shows an operation example in pulse period measurement mode.

**Table 12.6 Pulse Period Measurement Mode Specifications**

Item	Specification
Count source	f1, f2, f8, f32
Count operation	<ul style="list-style-type: none"> <li>Down-count</li> <li>After an active edge of measurement pulse is input, contents in the read-out buffer is retained in the first underflow of prescaler X. Then the timer X reloads contents in the reload register in the second underflow of prescaler X and continues counting.</li> </ul>
Count start condition	Write "1" (count start) to TXS bit in TXMR register
Count stop condition	Write "0" (count stop) to TXS bit in TXMR register
Interrupt request generation timing	<ul style="list-style-type: none"> <li>When Timer X underflows or reloads [Timer X interrupt]</li> <li>Rising or falling of CNTR0 input (end of measurement period) [INT1 interrupt]</li> </ul>
INT1/CNTR0 pin function	Measurement pulse input <sup>(1)</sup> (INT1 interrupt input)
CNTR0 pin function	Programmable I/O port
Read from timer	Contents in the read-out buffer can be read by reading TX register. The value retained in the read-out buffer is released by reading TX register.
Write to timer	Value written to TX register is written to both reload register and counter. Same applies to PREX register.
Select function	<ul style="list-style-type: none"> <li>INT1/CNTR0 polarity switching function</li> <li>Measurement period of input pulse can be selected with R0EDG bit.</li> </ul>

**NOTES:**

- The period of input pulse must be longer than twice the period of prescaler X. Longer pulse for H width and L width than the prescaler X period must be input. If shorter pulse than the period is input to the CNTR0 pin, the input may be disabled.

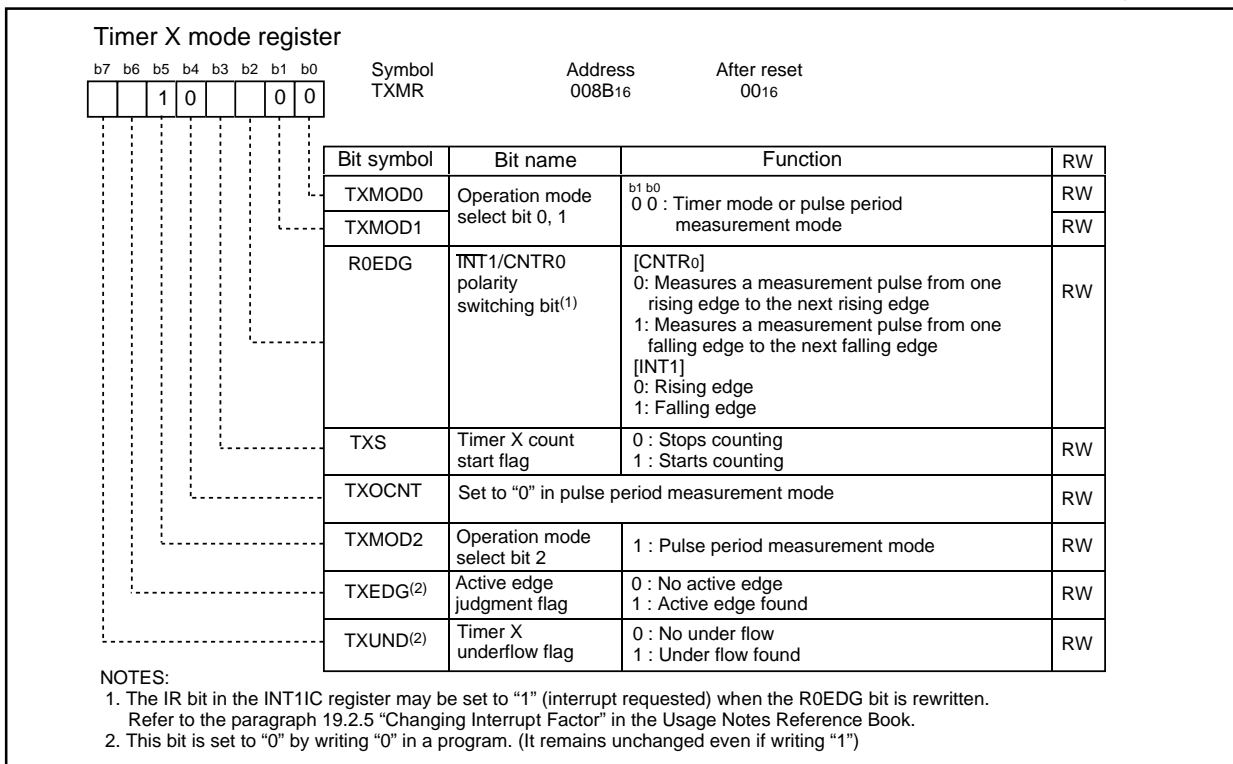

**Figure 12.9 TXMR Register in Pulse Period Measurement Mode**

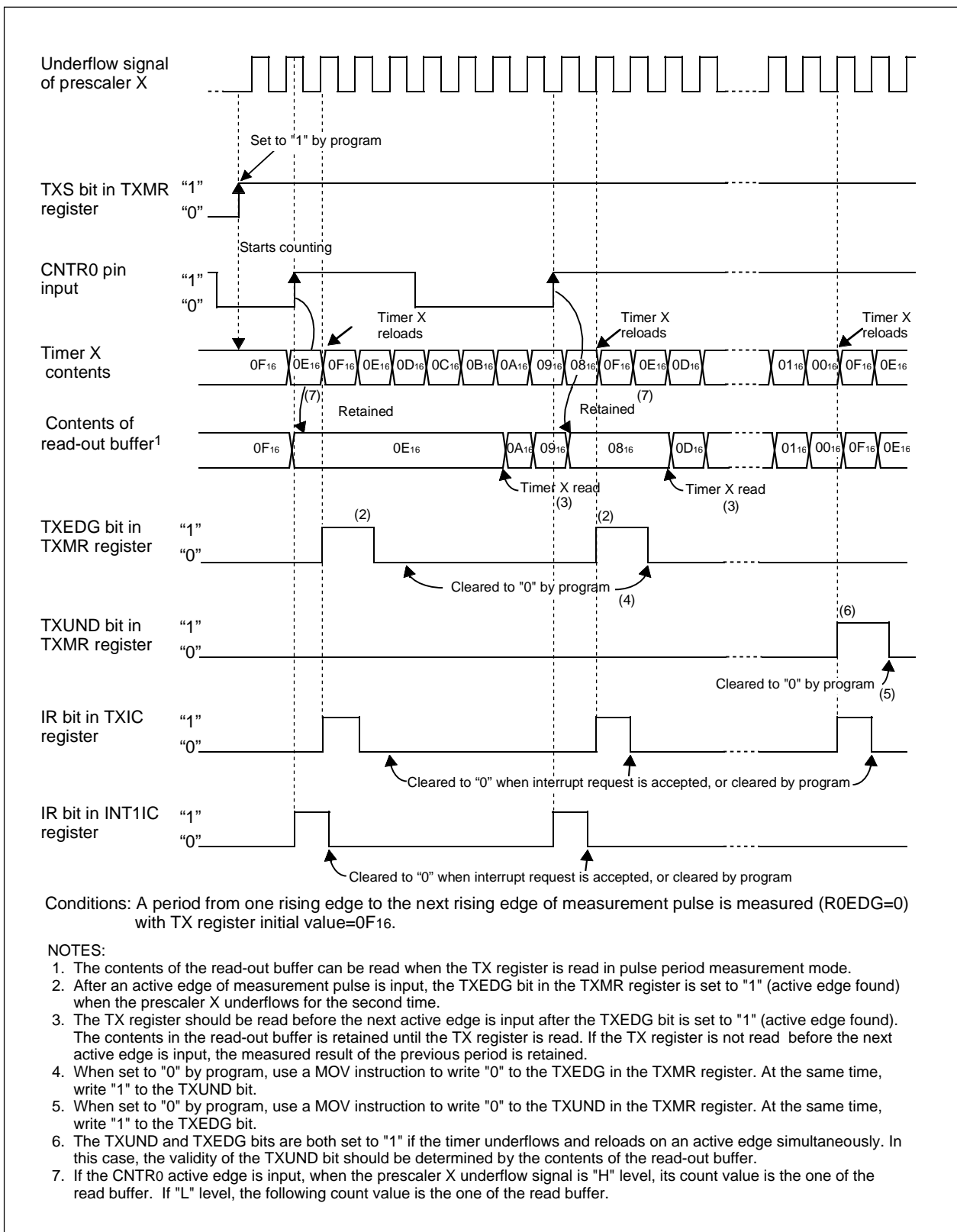

Figure 12.10 Operation Example in Pulse Period Measurement Mode

### 12.2 Timer Y

Timer Y is an 8-bit timer with an 8-bit prescaler and has two reload registers-Timer Y Primary and Timer Y Secondary. Figure 12.11 shows a block diagram of Timer Y. Figures 12.12 to 12.14 show the TYZMR, PREY, TYSC, TYPR, TYZOC, PUM, and YCSS registers.

The Timer Y has two operation modes as follows:

- Timer mode: The timer counts an internal count source (clock source).
- Programmable waveform generation mode: The timer outputs pulses of a given width successively.

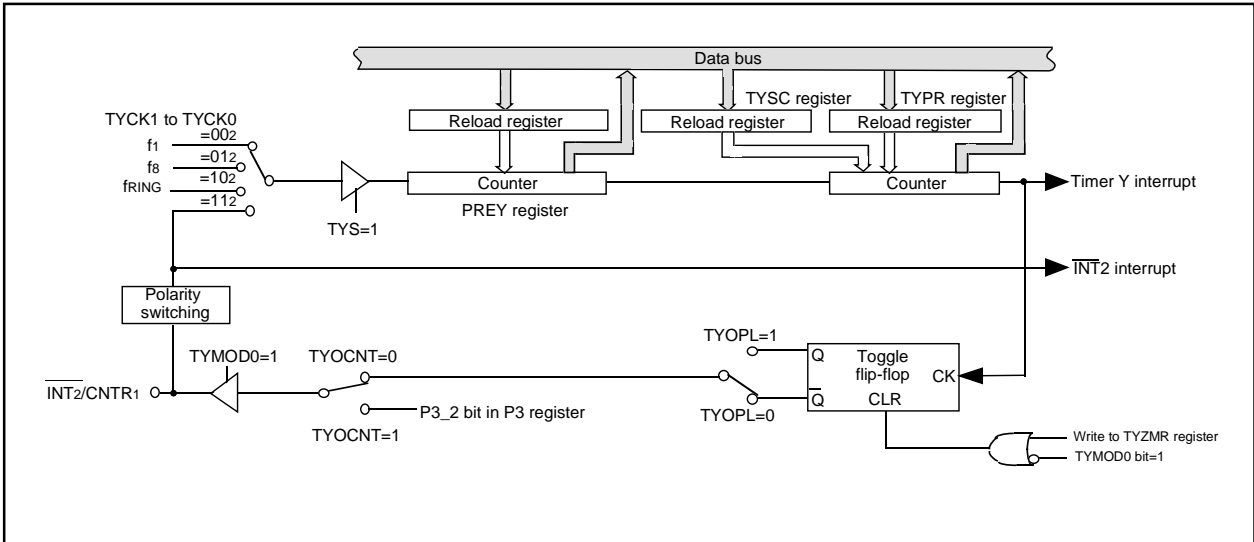

Figure 12.11 Timer Y Block Diagram

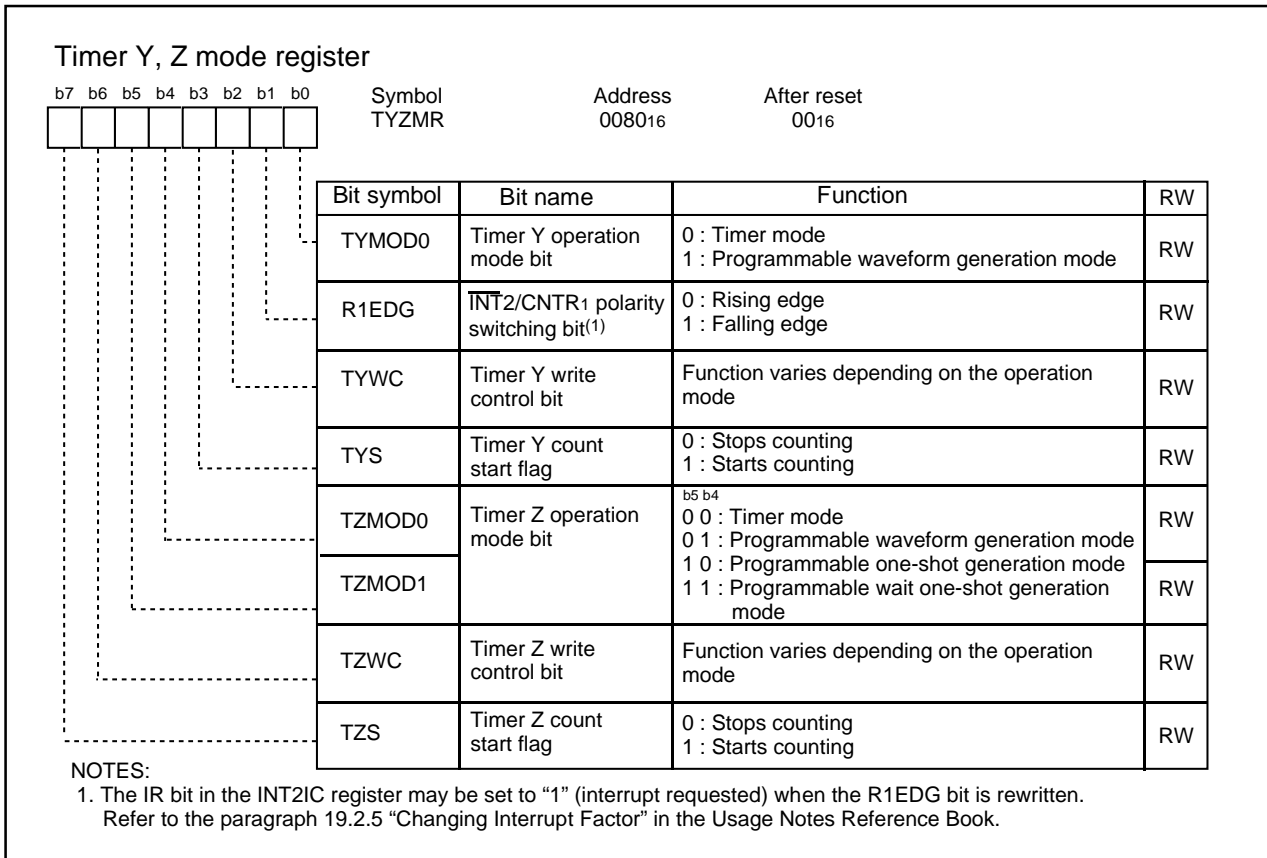

Figure 12.12 TYZMR Register

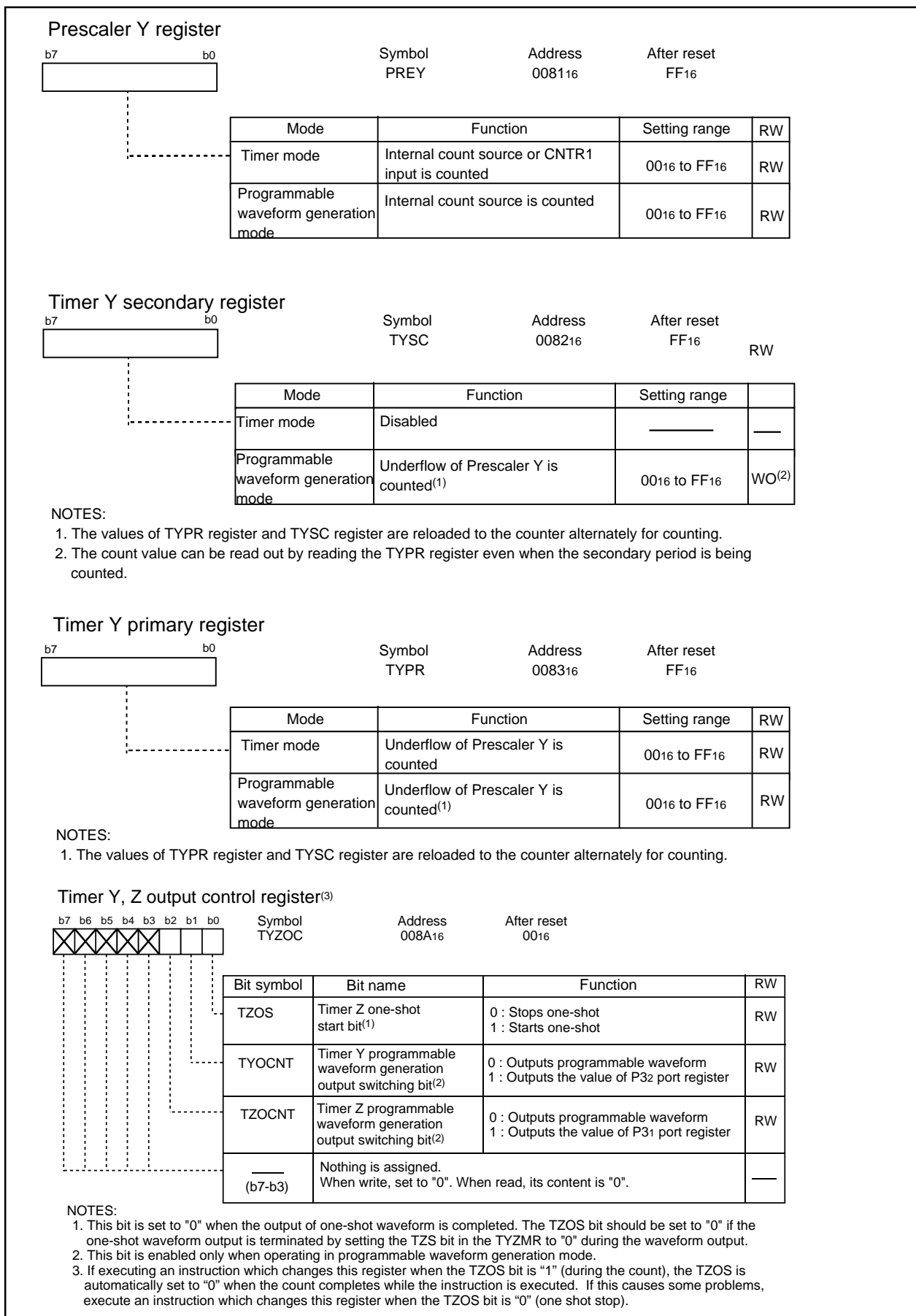

Figure 12.13 PREY Register, TYSC Register, TYPR Register, and TYZOC Register

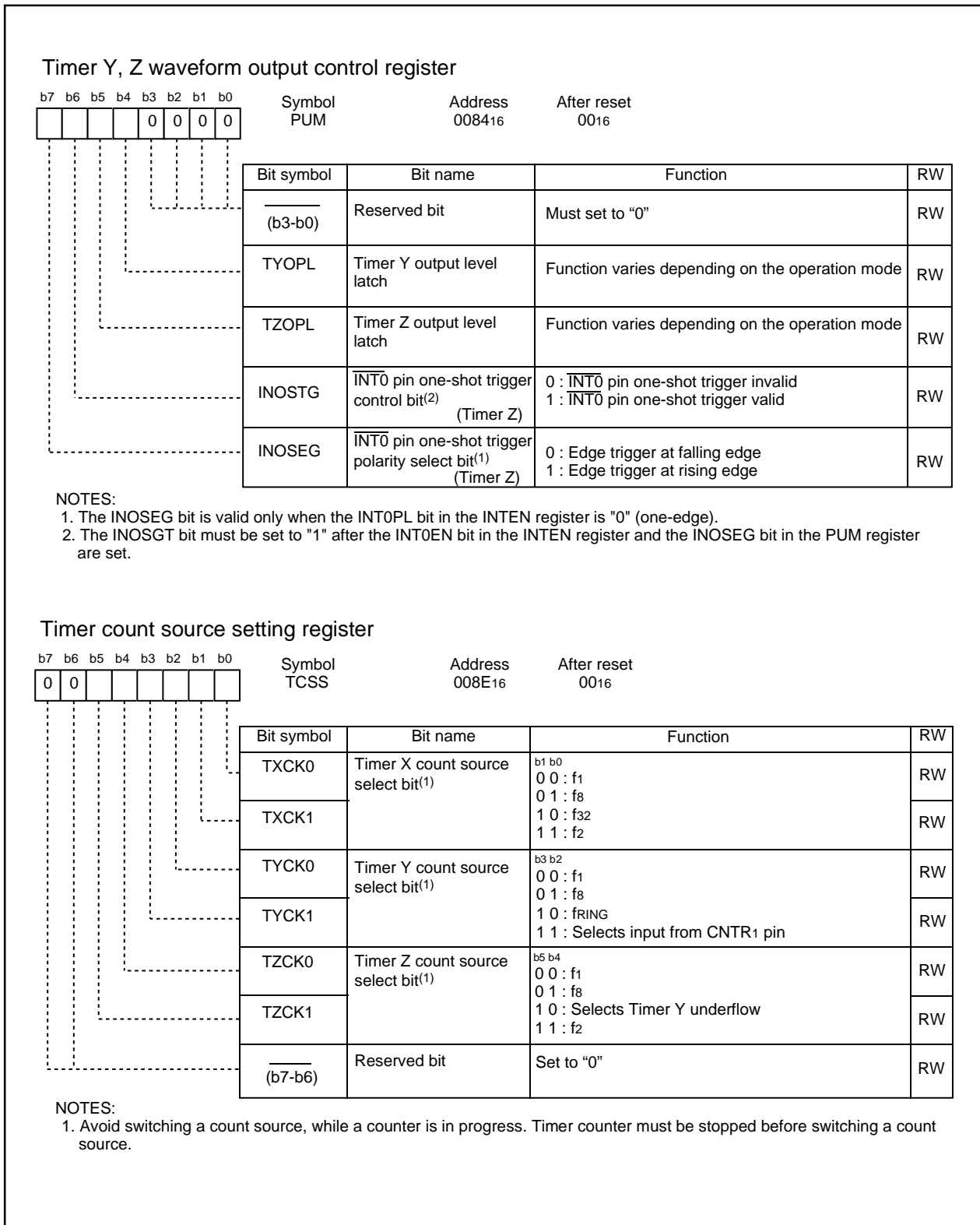

Figure 12.14 PUM Register and TCSS Register

### 12.2.1 Timer Mode

In this mode, the timer counts an internally generated count source (see “Table 12.7 Timer Mode Specifications”). An external signal input to the CNTR1 pin can be counted. The TYSC register is unused in timer mode. Figure 12.15 shows the TYZMR and PUM registers in timer mode.

**Table 12.7 Timer Mode Specifications**

Item	Specification
Count source	f1, f8, fRING, external signal fed to CNTR1 pin
Count operation	<ul style="list-style-type: none"> <li>• Down-count</li> <li>• When the timer underflows, it reloads the reload register contents before continuing counting (When the Timer Y underflows, the contents of the Timer Y primary reload register is reloaded.)</li> </ul>
Divide ratio	$1/(n+1)(m+1)$ n: set value in PREY register, m: set value in TYPR register
Count start condition	Write “1” (count start) to TYS bit in TYZMR register
Count stop condition	Write “0” (count stop) to TYS bit in TYZMR register
Interrupt request generation timing	<ul style="list-style-type: none"> <li>• When Timer Y underflows [Timer Y interrupt]</li> </ul>
INT2/CNTR1 pin function	Programmable I/O port, count source input or $\overline{\text{INT2}}$ interrupt input <ul style="list-style-type: none"> <li>• When the TYCK1 to TYCK0 bits in the TCSS register are set to “00b”, “01b” or “10b” (Timer Y count source is f1, f8 or fRING), programmable I/O port or <math>\overline{\text{INT2}}</math> interrupt input</li> <li>• When the TYCK1 to TYCK0 bits are set to “11b” (Timer Y count source is CNTR1 input), count source input (<math>\overline{\text{INT2}}</math> interrupt input)</li> </ul>
Read from timer	Count value can be read out by reading TYPR register. Same applies to PREY register.
Write to timer <sup>(1)</sup>	Value written to TYPR register is written to both reload register and counter or written to only reload register. Selected by program. Same applies to PREY register.
Select function	<ul style="list-style-type: none"> <li>• Event counter function When setting TYCK1 to TYCK0 bits to “112”, an external signal fed to CNTR1 pin is counted.</li> <li>• INT2/CNTR1 switching bit Active edge of count source is selected by R1EDG bit.</li> </ul>

**NOTES:**

1. The IR bit in the TYIC register is set to “1” (interrupt requested) if you write to the TYPR or PREY register while both of the following conditions are met.

Conditions:

- TYWC bit in TYZMR register is “0” (write to reload register and counter simultaneously)
- TYS bit is “1” (count start)

To write to the TYPR or PREY register in the above state, disable interrupts before writing.

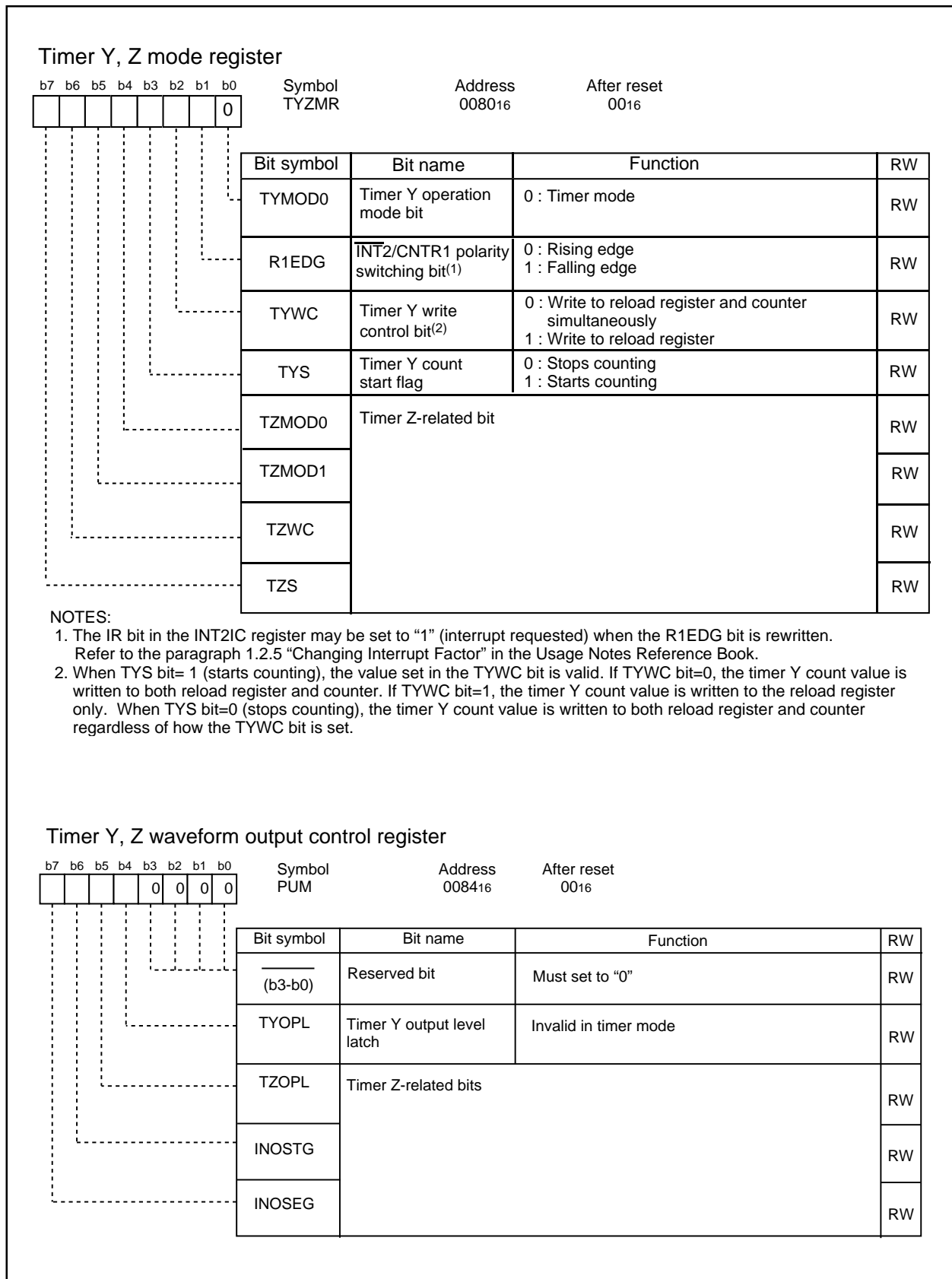

Figure 12.15 TYZMR Register and PUM Register in Timer Mode

### 12.2.2 Programmable Waveform Generation Mode

In this mode, an signal output from the TYOUT pin is inverted each time the counter underflows, while the values in the TYPR register and TYSC register are counted alternately (see "Table 12.8 Programmable Waveform Generation Mode Specifications"). A counting starts by counting the set value in the TYPR register. Figure 12.16 shows the TYZMR register in programmable waveform generation mode. Figure 12.17 shows the operation example.

**Table 12.8 Programmable Waveform Generation Mode Specifications**

Item	Specification
Count source	f1, f8, fRING
Count operation	<ul style="list-style-type: none"> <li>Down count</li> <li>When the timer underflows, it reloads the contents of primary reload register and secondary reload register alternately before continuing counting.</li> </ul>
Output waveform width and period	Primary period : $(n+1)(m+1)/f_i$ Secondary period : $(n+1)(p+1)/f_i$ Period : $(n+1)\{(m+1)+(p+1)\}/f_i$ n: set value in PREY register, m: set value in TYPR register, p: set value in TYSC register f <sub>i</sub> : Count source frequency
Count start condition	Write "1" (count start) to TYS bit in TYZMR register
Count stop condition	Write "0" (count stop) to TYS bit in TYZMR register
Interrupt request generation timing	In half of count source, after Timer Y underflows during secondary period (at the same time as the CNTR1 output change) [Timer Y interrupt].
INT2/CNTR1 pin functions	Pulse output Use timer mode when using this pin as a programmable I/O port.
Read from timer	Count value can be read out by reading TYPR register. Same applies to PREY register <sup>(1)</sup> .
Write to timer	Value written to TYPR register is written to only reload register. Same applies to TYSC register and PREY register <sup>(2)</sup> .
Select function	<ul style="list-style-type: none"> <li>Output level latch select function The output level during primary and secondary periods is selected by the TYOPL bit.</li> <li>Programmable waveform generation output switching function When the TYOCNT bit in the TYZOC register is set to "0", the output from TYOUT is inverted synchronously when Timer Y underflows during the secondary period. And when set to "1", a value in the P3_2 bit is output from TYOUT synchronously when Timer Y underflows during the secondary period<sup>(3)</sup>.</li> </ul>

**NOTES:**

- Even when counting the secondary period, read out the TYPR register.
- The set value in the TYPR register and TYSC register are made effective by writing a value to the TYPR register. The written values are reflected to the waveform output from the next primary period after writing to the TYPR register.
- The TYOCNTbit is enabled in the following timings
  - When count starts
  - When Timer Y interrupt request is generated

Therefore, pulse is output from the next primary period depending on the setting value of the TYOCNT bit.



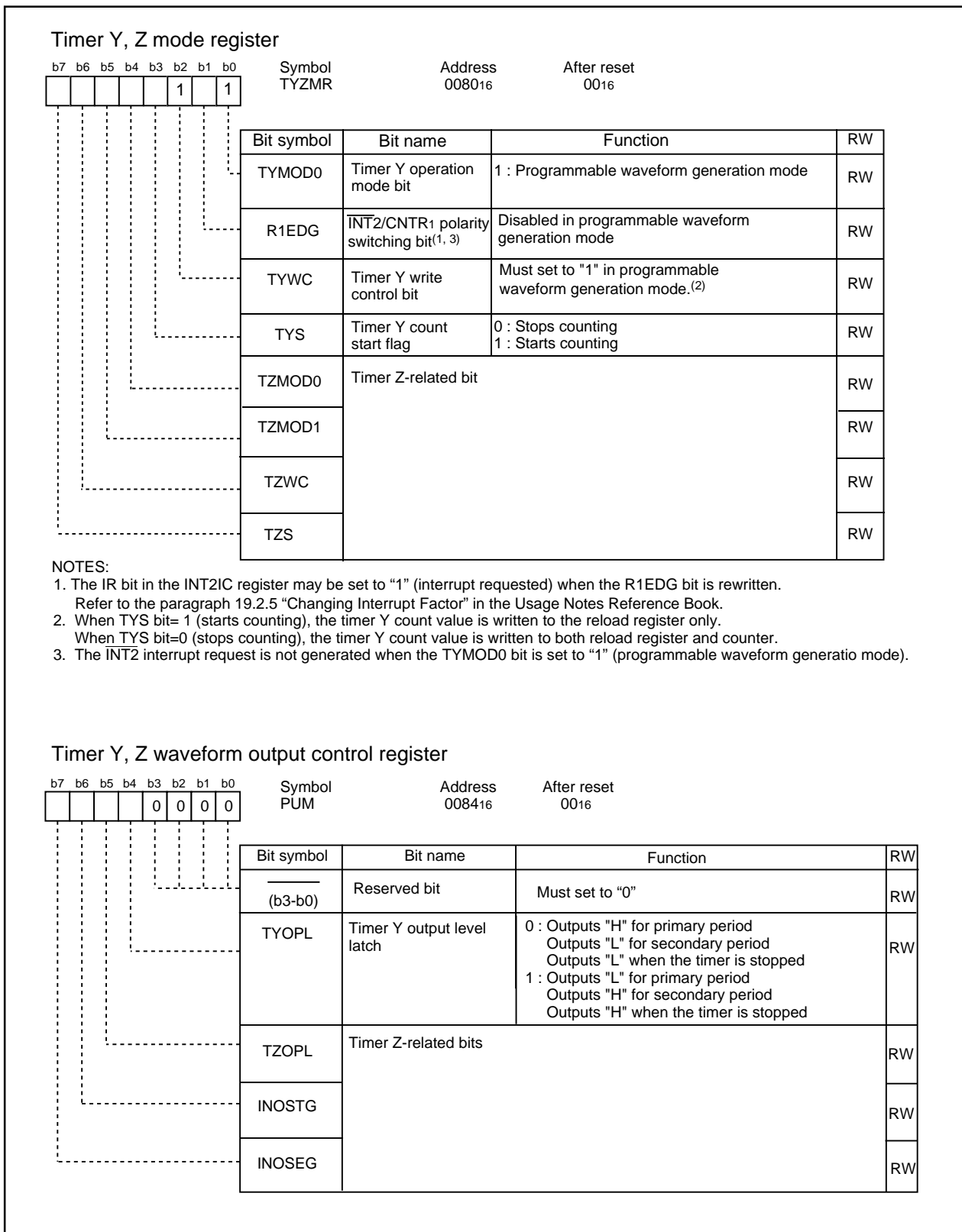

Figure 12.16 TYZMR Register and PUM Register in Programmable Waveform Generation Mode

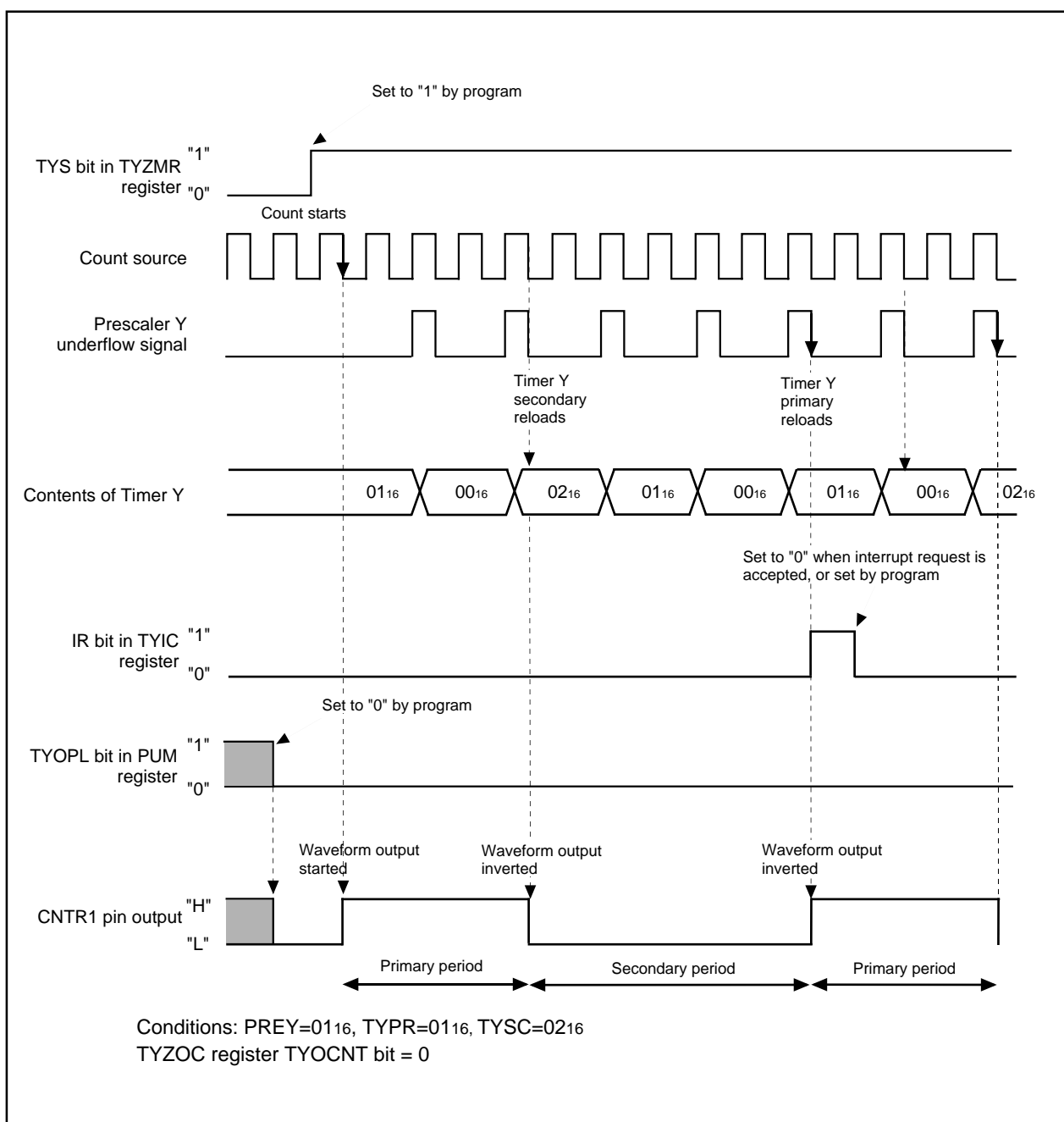

Figure 12.17 Timer Y Operation Example in Programmable Waveform Generation Mode

### 12.3 Timer Z

Timer Z is an 8-bit timer with an 8-bit prescaler and has two reload registers-Timer Z Primary and Timer Z Secondary. Figure 12.18 shows a block diagram of Timer Z. Figures 12.19 to 12.21 show the TYZMR, PREZ, TZSC, TZPR, TYZOC, PUM, and TCSS registers.

Timer Z has the following four operation modes.

- Timer mode: The timer counts an internal count source or Timer Y underflow.
- Programmable waveform generation mode: The timer outputs pulses of a given width successively.
- Programmable one-shot generation mode: The timer outputs one-shot pulse.
- Programmable wait one-shot generation mode: The timer outputs delayed one-shot pulse.

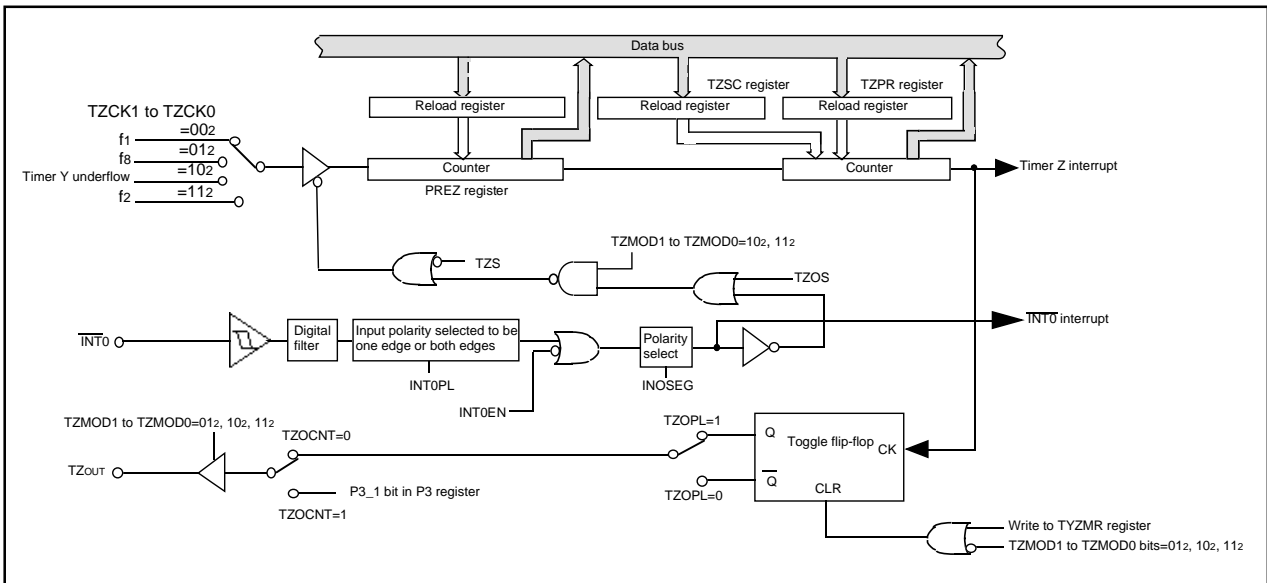

Figure 12.18 Timer Z Block Diagram

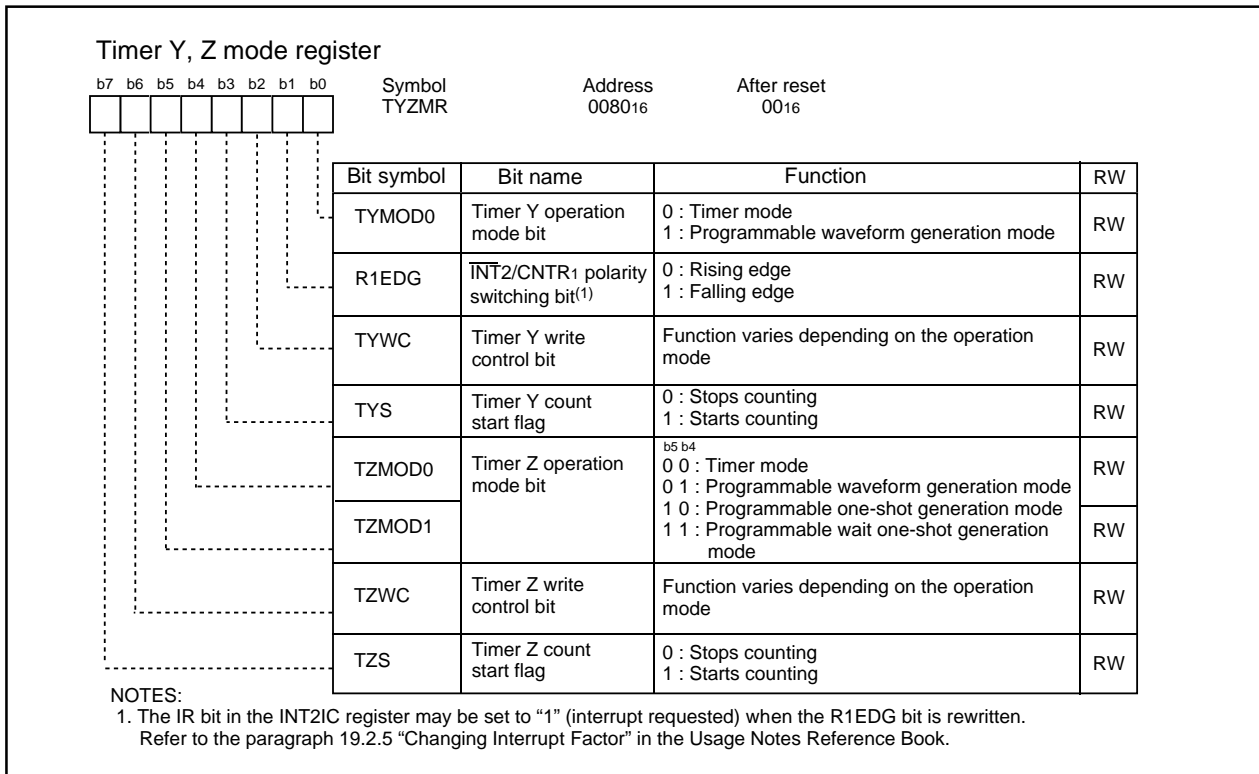
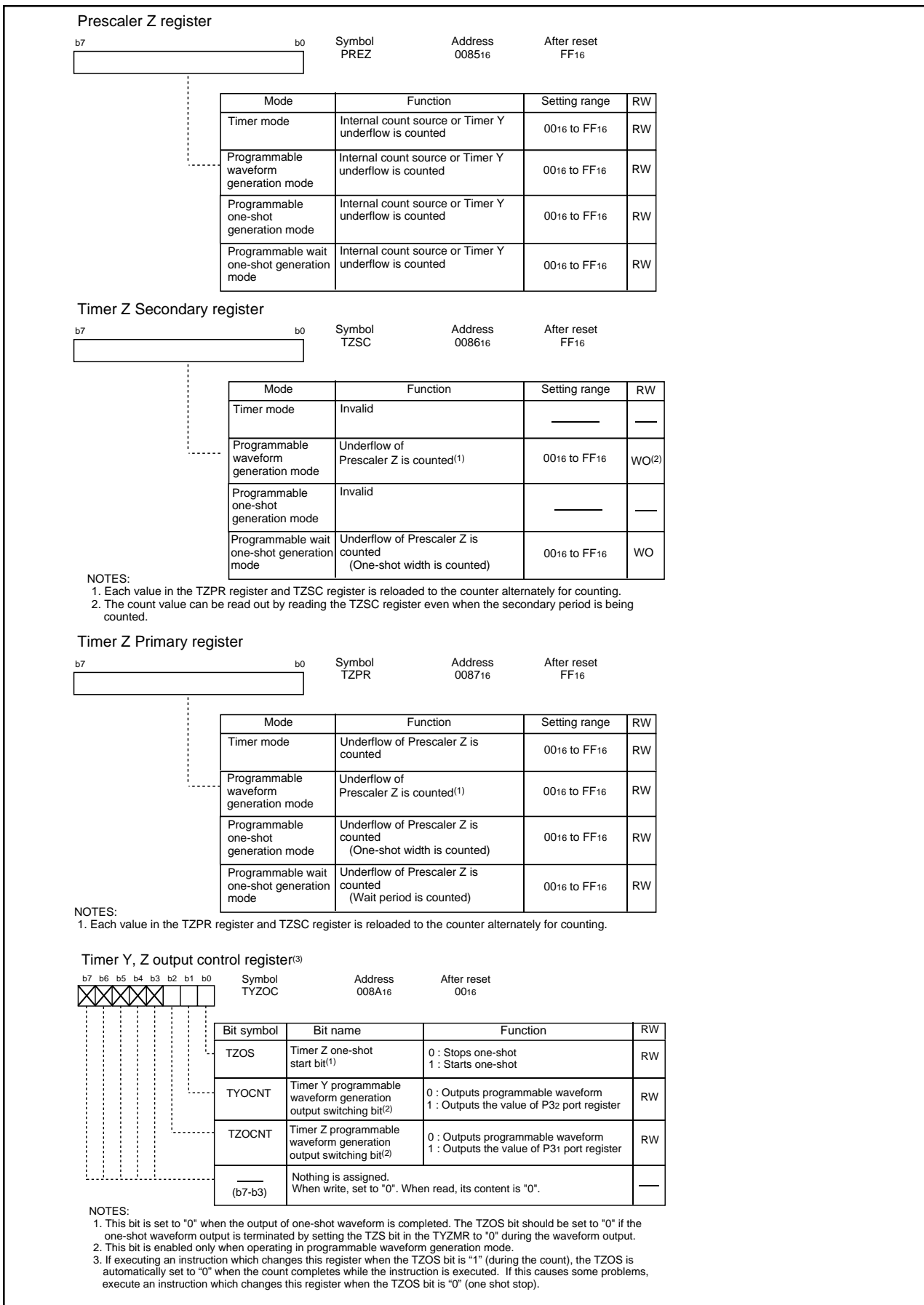

Figure 12.19 TYZMR Register



**Figure 12.20 PREZ Register, TZSC Register, TZPR Register, and TYZOC Register**

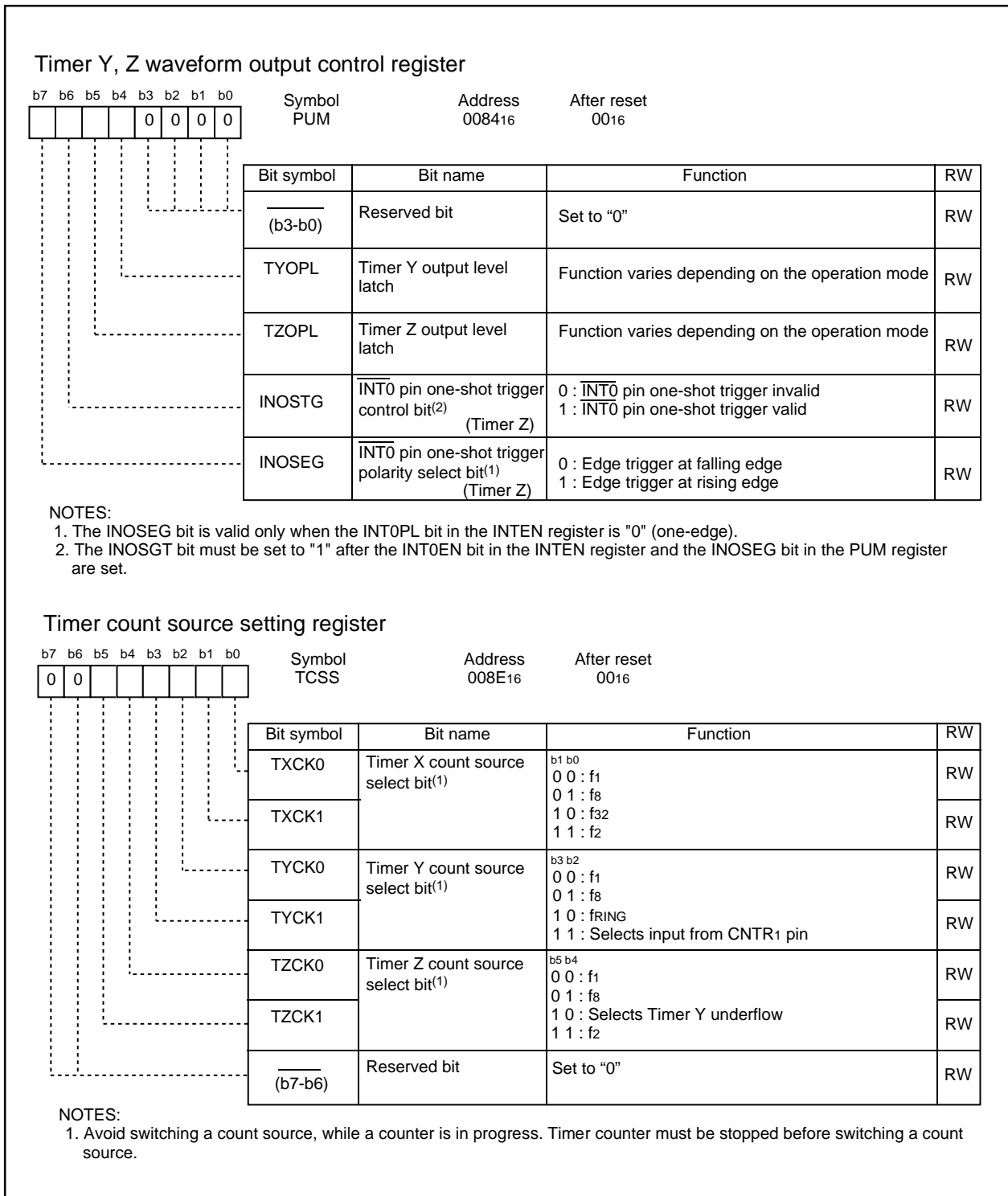

Figure 12.21 PUM Register and TCSS Register

### 12.3.1 Timer Mode

In this mode, the timer counts an internally generated count source or Timer Y underflow (see "Table 12.9 Timer Mode Specifications"). The TZSC register is unused in timer mode. Figure 12.22 shows the TYZMR register and PUM register in timer mode.

**Table 12.9 Timer Mode Specifications**

Item	Specification
Count source	f1, f2, f8, Timer Y underflow
Count operation	<ul style="list-style-type: none"> <li>• Down-count</li> <li>• When the timer underflows, it reloads the reload register contents before continuing counting (When the Timer Z underflows, the contents of the Timer Z primary reload register is reloaded.)</li> </ul>
Divide ratio	$1/(n+1)(m+1)$ n: set value in PREZ register, m: set value in TZPR register
Count start condition	Write "1" (count start) to TZS bit in TYZMR register
Count stop condition	Write "0" (count stop) to TZS bit in TYZMR register
Interrupt request generation timing	<ul style="list-style-type: none"> <li>• When Timer Z underflows [Timer Z interrupt]</li> </ul>
TZOUT pin function	Programmable I/O port
INT0 pin function	Programmable I/O port, or INT0 interrupt input
Read from timer	Count value can be read out by reading TZPR register. Same applies to PREZ register.
Write to timer <sup>(1)</sup>	Value written to TZPR register is written to both reload register and counter or written to reload register only. Selected by program. Same applies to PREZ register.

**NOTES:**

1. The IR bit in the TZIC register is set to "1" (interrupt requested) if you write to the TZPR or PREZ register while both of the following conditions are met.

<Conditions>

- TZWC bit in TYZMR register is set to "0" (write to reload register and counter simultaneously)
- TZS bit in TYZMR register is set to "1" (count start)

To write to the TZPR or PREZ register in the above state, disable interrupts before the writing.

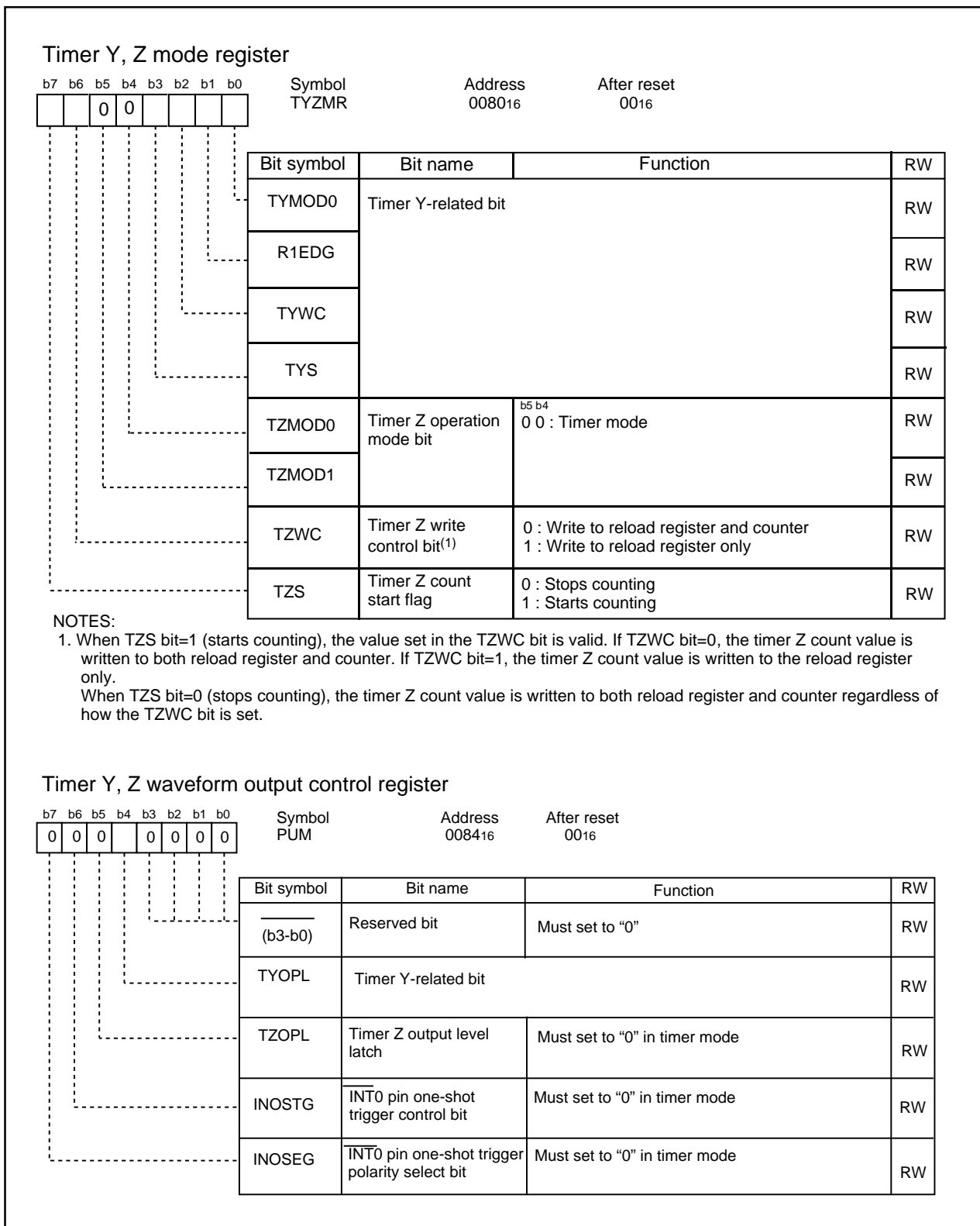

Figure 12.22 TYZMR Register and PUM Register in Timer Mode

### 12.3.2 Programmable Waveform Generation Mode

In this mode, an signal output from the TZOUT pin is inverted each time the counter underflows, while the values in the TZPR register and TZSC register are counted alternately (see “Table 12.10 Programmable Waveform Generation Mode Specifications”). A counting starts by counting the value set in the TZPR register. Figure 12.23 shows TYZMR and PUM registers in this mode. The Timer Z operates in the same way as the Timer Y in this mode. See Figure 12.17 (Timer Y operation example in programmable waveform generation mode ).

**Table 12.10 Programmable Waveform Generation Mode Specifications**

Item	Specification
Count source	f1, f2, f8, Timer Y underflow
Count operation	<ul style="list-style-type: none"> <li>Down-count</li> <li>When the timer underflows, it reloads the contents of primary reload register and secondary reload register alternately before continuing counting.</li> </ul>
Output waveform width and period	Primary period : $(n+1)(m+1)/f_i$ Secondary period : $(n+1)(p+1)/f_i$ Period : $(n+1)\{(m+1)+(p+1)\}/f_i$ $f_i$ : Count source frequency $n$ : Set value in PREZ register, $m$ : Set value in TZPR register, $p$ : Set value in TZSC register
Count start condition	Write “1” (count start) to the TZS bit in the TYZMR register
Count stop condition	Write “0” (count stop) to the TZS bit in the TYZMR register
Interrupt request generation timing	In half of count source, after Timer Z underflows during secondary period (at the same time as the TZout output change) [Timer Z interrupt].
TZOUT pin function	Pulse output Use timer mode when using this pin as a programmable I/O port.
INT0 pin functions	Programmable I/O port, or INT0 interrupt input
Read from timer	Count value can be read out by reading TZPR register. Same applies to PREZ register <sup>(1)</sup> .
Write to timer	Value written to TZPR register is written to reload register only. Same applies to TZSC register and PREZ register <sup>(2)</sup> .
Select function	<ul style="list-style-type: none"> <li>Output level latch select function The output level during primary and secondary periods is selected by the TZOPL bit.</li> <li>Programmable waveform generation output switching function The output from TZOUT is inverted synchronously when Timer Z underflows by setting the TZOCNT bit in the TYZOC register to “0”. A value in the P3_1 bit is output from the TZOUT by setting to “1”<sup>(3)</sup>.</li> </ul>

**NOTES:**

- Even when counting the secondary period, read out the TZPR register.
- The set value in the TZPR register and TZSC register are made effective by writing a value to the TZPR register. The set values are reflected to the waveform output beginning with the next primary period after writing to the Timer Z primary register.
- The TZOCNTbit is enabled in the following timings
  - When count starts
  - When Timer Z interrupt request is generated
 Therefore, pulse is output from the next primary period depending on the setting value of the TZOCNT bit.



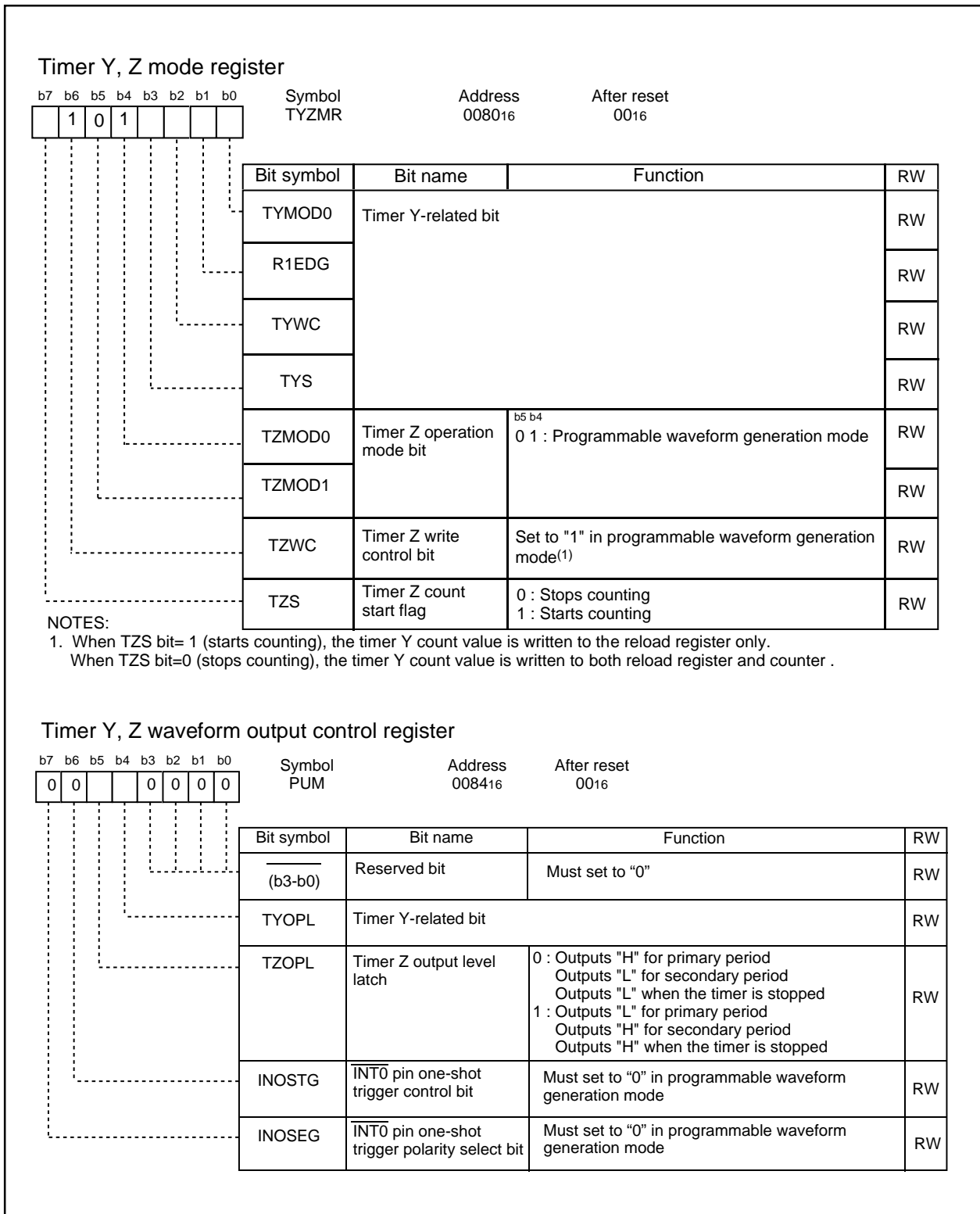

Figure 12.23 TYZMR Register and PUM Register in Programmable Waveform Generation Mode

### 12.3.3 Programmable One-shot Generation Mode

In this mode, upon program command or external trigger input (input to the  $\overline{\text{INT0}}$  pin), the microcomputer outputs the one-shot pulse from the TZOUT pin (see “Table 12.11 Programmable One-shot Generation Mode Specifications”). When a trigger occurs, the timer starts operating from the point only once for a given period equal to the set value in the TZPR register. The TZSC is unused in this mode. Figure 12.24 shows the TYZMR register and PUM register in this mode. Figure 12.25 shows an operation example in this mode.

**Table 12.11 Programmable One-shot Generation Mode Specifications**

Item	Specification
Count source	f1, f2, f8, Timer Y underflow
Count operation	<ul style="list-style-type: none"> <li>• Downcounts set value in TZPR register</li> <li>• When the timer underflows, it reloads the contents of reload register before completing counting and the TZOS bit is “0”.</li> <li>• When a count stops, the timer reloads the contents of the reload register before it stops.</li> </ul>
One-shot pulse output duration	$(n+1)(m+1)/f_i$ f <sub>i</sub> : count source frequency, n: set value in PREZ register, m: set value in TZPR register
Count start condition	<ul style="list-style-type: none"> <li>• Set TZOS bit in TYZOC register to “1” (start one-shot)<sup>(1)</sup></li> <li>• Input active trigger to <math>\overline{\text{INT0}}</math> pin<sup>(2)</sup></li> </ul>
Count stop condition	<ul style="list-style-type: none"> <li>• When reloading is completed after count value was set to “0016”</li> <li>• When TZS bit in TYZMR register is set to “0” (stop counting)</li> <li>• When TZOS bit in TYZOC register is set to “0” (stop one-shot)</li> </ul>
Interrupt request generation timing	In half cycles of count source, after the timer underflows (at the same time as the TZout output ends) [Timer Z interrupt].
TZOUT pin function	Pulse output Use timer mode when using this pin as a programmable I/O port.
$\overline{\text{INT0}}$ pin function	Programmable I/O port, $\overline{\text{INT0}}$ interrupt input or external trigger input <ul style="list-style-type: none"> <li>• When the INOSTG bit in the PUM register is set to “0” (<math>\overline{\text{INT0}}</math> one-shot trigger disabled) Programmable I/O port or <math>\overline{\text{INT0}}</math> interrupt input</li> <li>• When the INOSTG bit in the PUM register is set to “1” (<math>\overline{\text{INT0}}</math> one-shot trigger enabled) external trigger (<math>\overline{\text{INT0}}</math> interrupt input)</li> </ul>
Read from timer	Count value can be read out by reading TZPR register. Same applies to PREZ register.
Write to timer	Value written to TZPR register is written to reload register only <sup>(3)</sup> . Same applies to PREZ register.
Select function	<ul style="list-style-type: none"> <li>• Output level latch select function Output level for one-shot pulse waveform is selected by TZOPL bit.</li> <li>• <math>\overline{\text{INT0}}</math> pin one-shot trigger control function and polarity select function Trigger input from <math>\overline{\text{INT0}}</math> pin can be set to active or inactive by INOSTG bit. Also, an active trigger's polarity can be selected by INOSEG bit.</li> </ul>

**NOTES:**

1. The TZS bit in the TYZMR register must be set to “1” (start counting).
2. The TZS bit must be set to “1” (start counting), the INT0EN bit in the INTEN register to “1” (enabling  $\overline{\text{INT0}}$  input), and the INOSTG bit in the PUM register to “1” (enabling  $\overline{\text{INT0}}$  one-shot trigger).  
Although the trigger input during counting cannot be acknowledged, the  $\overline{\text{INT0}}$  interrupt request is generated.
3. The set values are reflected beginning with the next one-shot pulse after writing to the TZPR register.

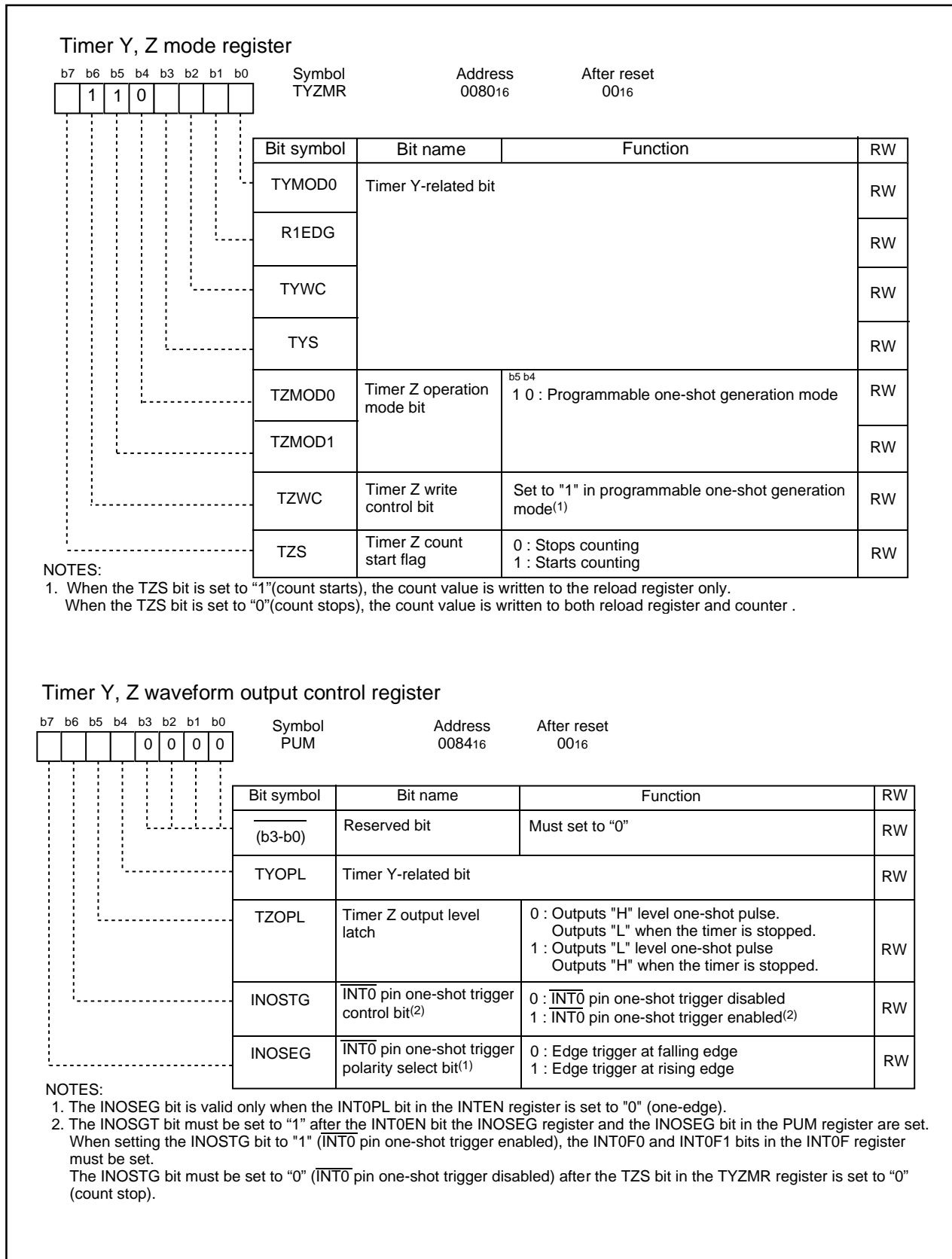

Figure 12.24 TYZMR Register and PUM Register in Programmable One-shot Generation Mode

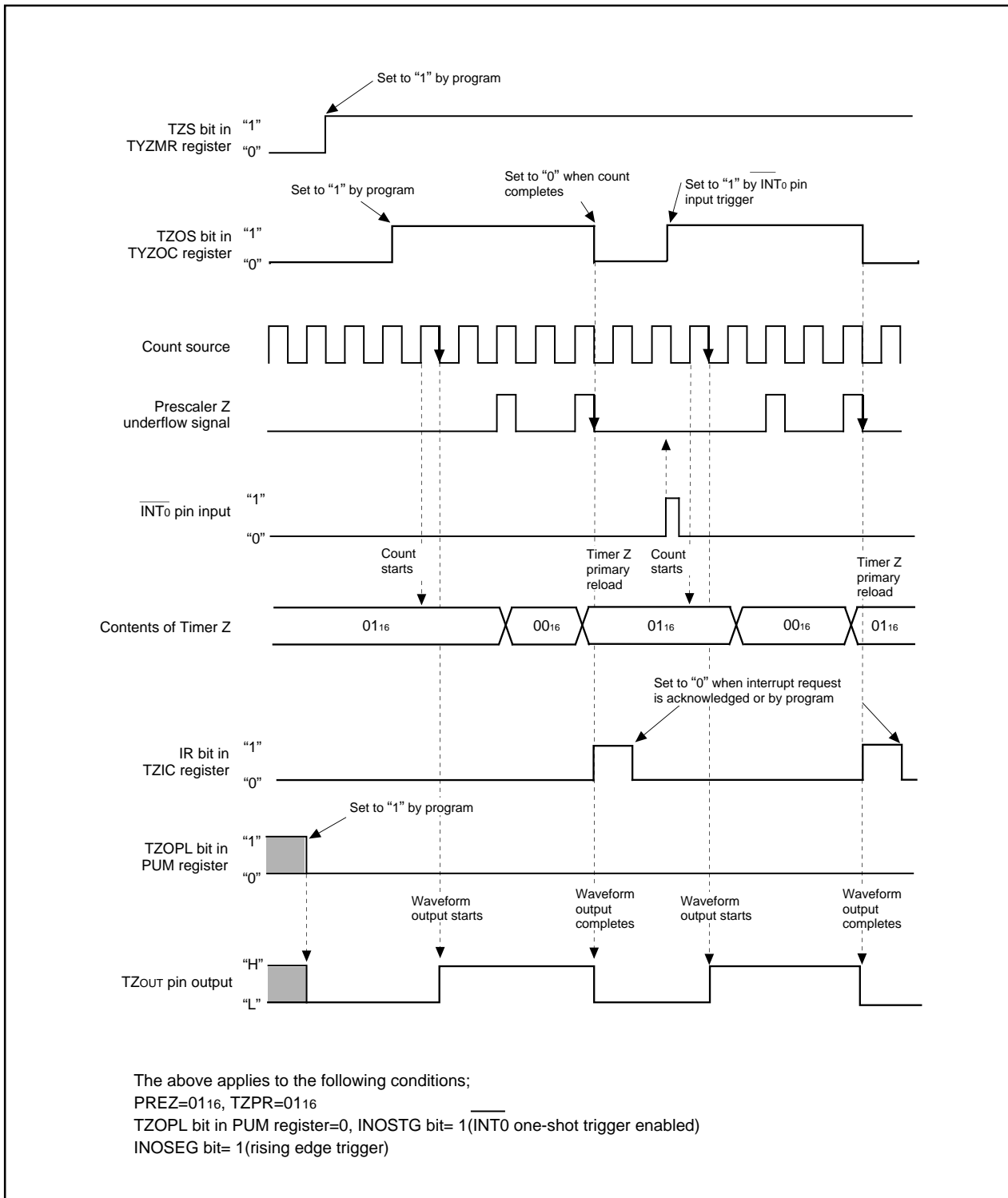

Figure 12.25 Operation Example in Programmable One-shot Generation Mode

### 12.3.4 Programmable Wait One-shot Generation Mode

In this mode, upon program or external trigger input (input to the  $\overline{\text{INT0}}$  pin), the microcomputer outputs the one-shot pulse from the TZOUT pin after waiting for a given length of time (see "Table 12.12 Programmable Wait One-shot Generation Mode Specifications"). When a trigger occurs, from this point, the timer starts outputting pulses only once for a given length of time equal to the set value in the TZSC register after waiting for a given length of time equal to the set value in the TZPR register. Figure 12.26 shows the TYZMR and PUM registers in this mode. Figure 12.27 shows an operation example in this mode.

**Table 12.12 Programmable Wait One-shot Generation Mode Specifications**

Item	Specification
Count source	f1, f2, f8, Timer Y underflow
Count operation	<ul style="list-style-type: none"> <li>Downcounts set value in Timer Z primary</li> <li>When a counting of TZPR register underflows, the timer reloads the contents of TZSC register before continuing counting.</li> <li>When a counting of TZSC register underflows, the timer reloads the contents of TZPR register before completing counting and the TZOS bit is "0".</li> <li>When a count stops, the timer reloads the contents of the reload register before it stops.</li> </ul>
Wait time	$(n+1)(m+1)/f_i$ n: set value in PREZ register, m: set value in TZPR register
One-shot pulse output time	$(n+1)(p+1)/f_i$ n: set value in PREZ, p: set value in TZSC register
Count start condition	<ul style="list-style-type: none"> <li>Set TZOS bit in TYZOC register to "1" (start one-shot)<sup>(1)</sup></li> <li>Input active trigger to <math>\overline{\text{INT0}}</math> pin<sup>(2)</sup></li> </ul>
Count stop condition	<ul style="list-style-type: none"> <li>When reloading is completed after Timer Z underflows during secondary period [Timer Z interrupt]</li> <li>When TZS bit in TYZMR register is set to "0" (stop counting)</li> <li>When TZOS bit in TYZOC register is set to "0" (stop one-shot)</li> </ul>
Interrupt request generation timing	1 n half cycles of count source, after count value at counting TZSC register is set "0016" (at the same time as the TZout output change) [Timer Z interrupt]
TZOUT pin function	Pulse output Use timer mode when using this pin as a programmable I/O port.
$\overline{\text{INT0}}$ pin function	Programmable I/O port, $\overline{\text{INT0}}$ interrupt input or external trigger input <ul style="list-style-type: none"> <li>When the INOSTG bit in the PUM register is set to "0" (<math>\overline{\text{INT0}}</math> one-shot trigger disabled) Programmable I/O port or <math>\overline{\text{INT0}}</math> interrupt input</li> <li>When the INOSTG bit in the PUM register is set to "1" (<math>\overline{\text{INT0}}</math> one-shot trigger enabled) external trigger (<math>\overline{\text{INT0}}</math> interrupt input)</li> </ul>
Read from timer	Count value can be read out by reading TZPR register. Same applies to PREZ register.
Write to timer	Value written to TZPR register and PREZ register are written to reload register only <sup>(3)</sup> . Same applies to TZSC register.
Select function	<ul style="list-style-type: none"> <li>Output level latch select function Output level for one-shot pulse waveform is selected by TZOPL bit.</li> <li><math>\overline{\text{INT0}}</math> pin one-shot trigger control function and polarity select function Trigger input from <math>\overline{\text{INT0}}</math> pin can be set to active or inactive by INOSTG bit. Also, an active trigger's polarity can be selected by INOSEG bit.</li> </ul>

**NOTES:**

- The TZS bit in the TYZMR register must be set to "1" (start counting).
- The TZS bit must be set to "1" (start counting), the  $\overline{\text{INT0}}$ EN bit in the INTEN register to "1" (enabling  $\overline{\text{INT0}}$  input), and the INOSTG bit in the PUM register to "1" (enabling  $\overline{\text{INT0}}$  one-shot trigger).  
Although the trigger input during counting cannot be acknowledged, the  $\overline{\text{INT0}}$  interrupt request is generated.
- The set values are reflected beginning with the next one-shot pulse after writing to the TZPR register.

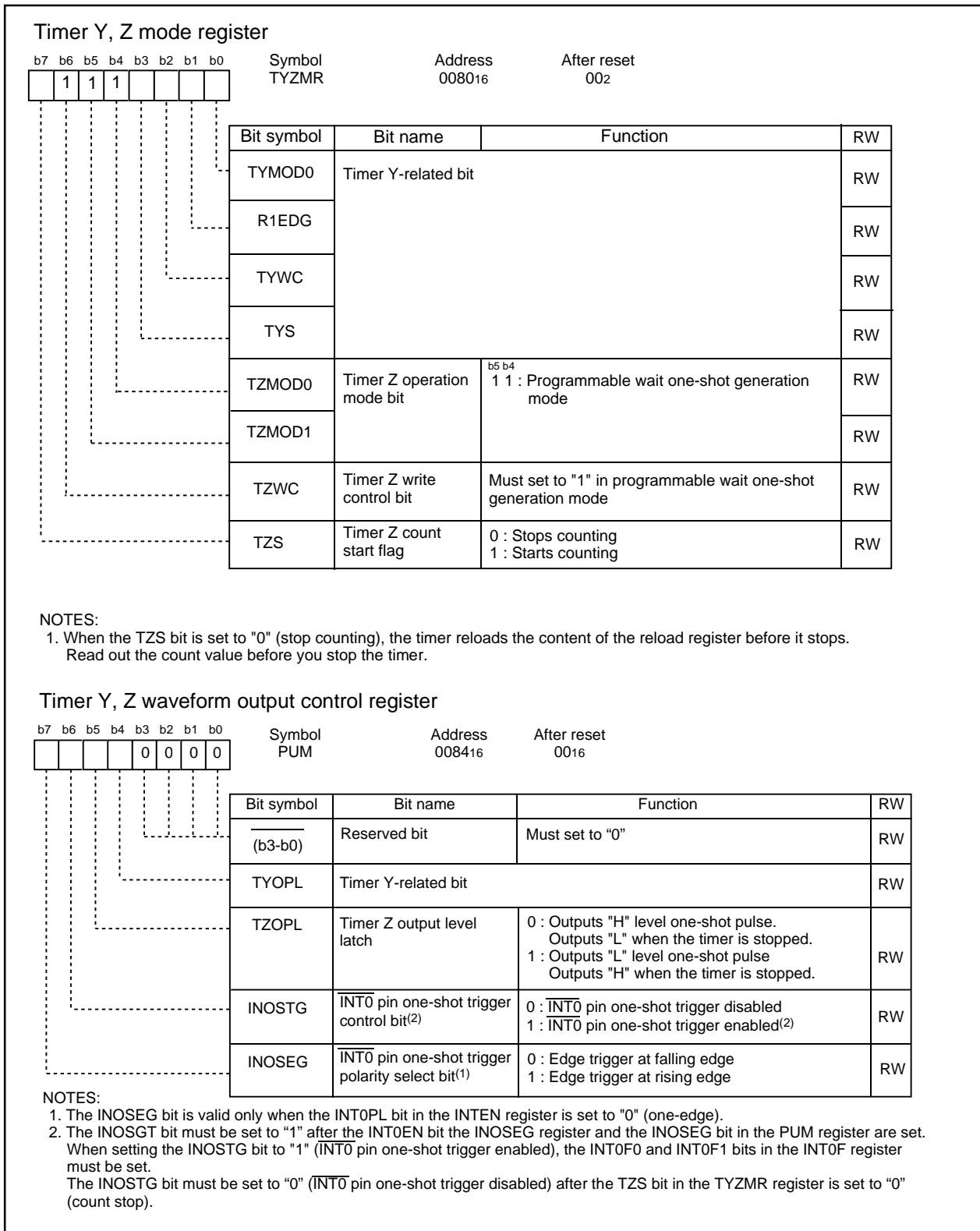

Figure 12.26 TYZMR Register and PUM Register in Programmable Wait One-shot Generation Mode

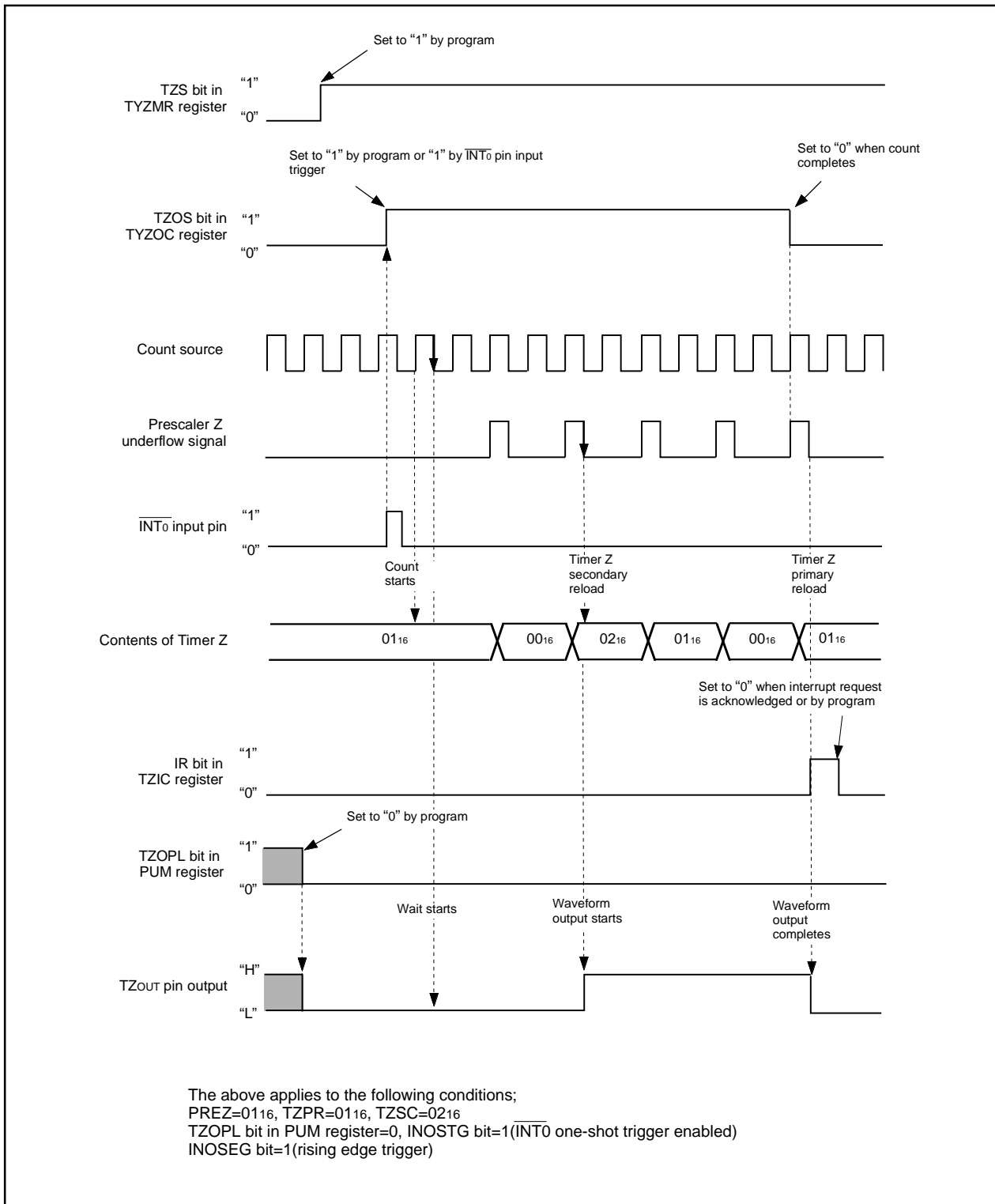

Figure 12.27 Operation Example in Programmable Wait One-shot Generation Mode

### 12.4 Timer C

Timer C is a 16-bit timer. Figure 12.28 shows a block diagram of Timer C. Figure 12.29 shows a block diagram of CMP waveform generation unit. Figure 12.30 shows a block diagram of CMP waveform output unit.

The Timer C has two modes: input capture mode and output compare mode.

Figures 12.31 shows TC, TM0, TM1, and TCC0 registers. Figure 12.32 shows TCC1 and TCOUT registers.

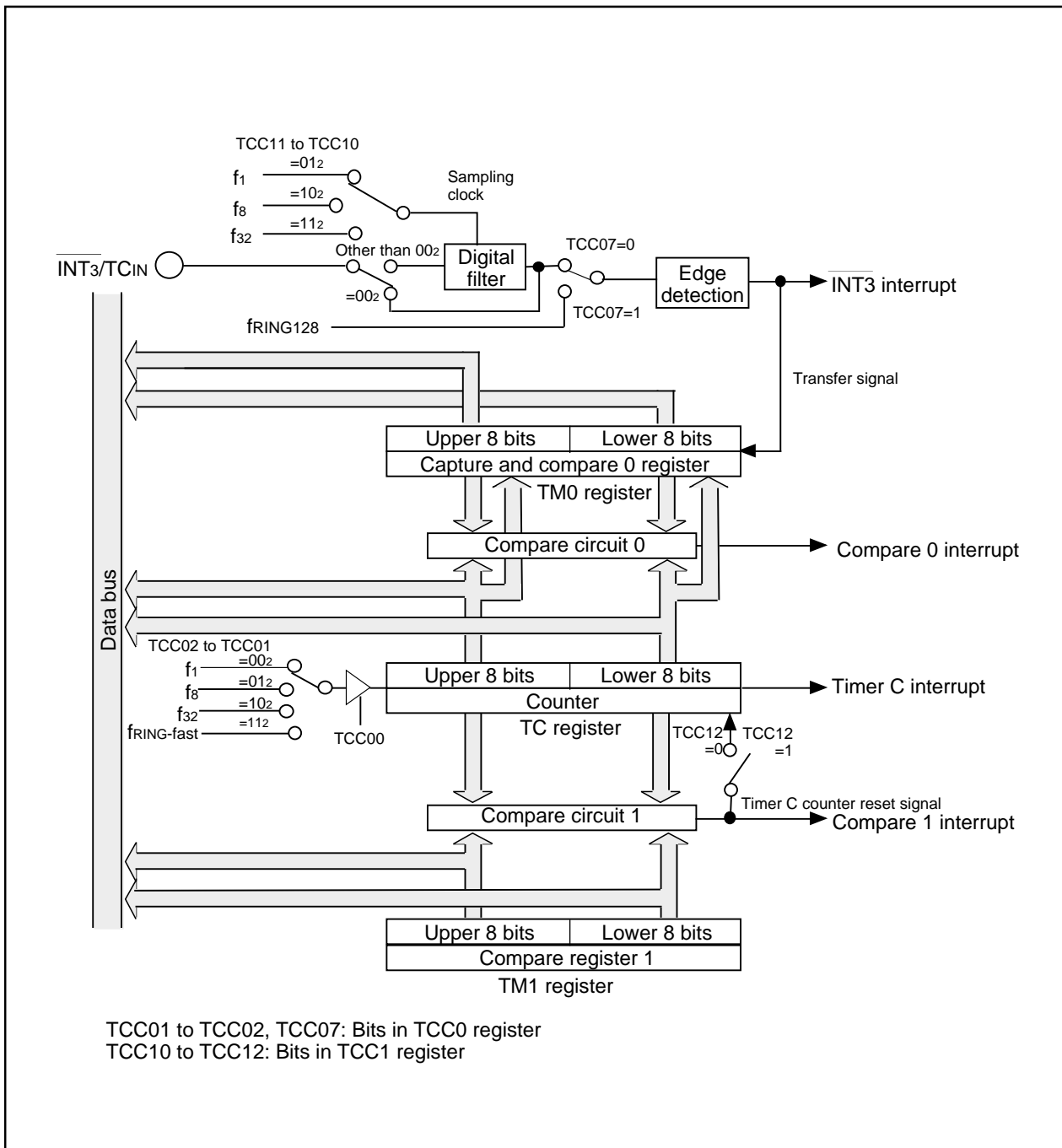

Figure 12.28 Timer C Block Diagram



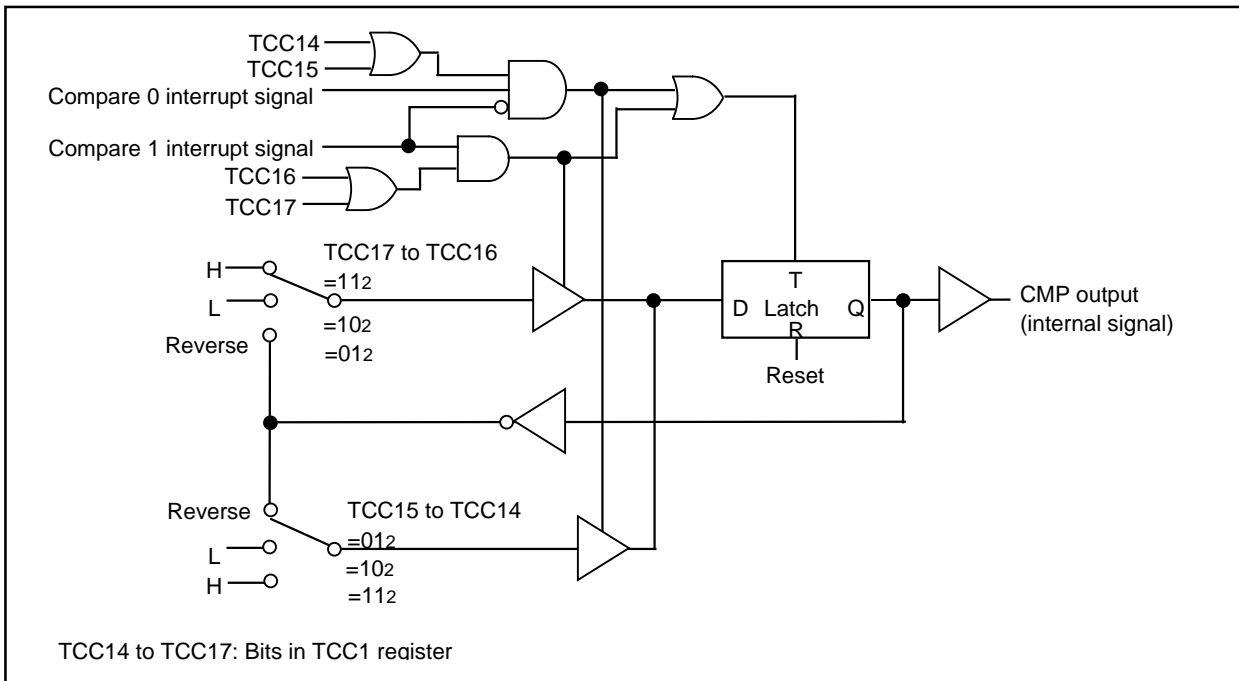

Figure 12.29 CMP Waveform Generation Unit

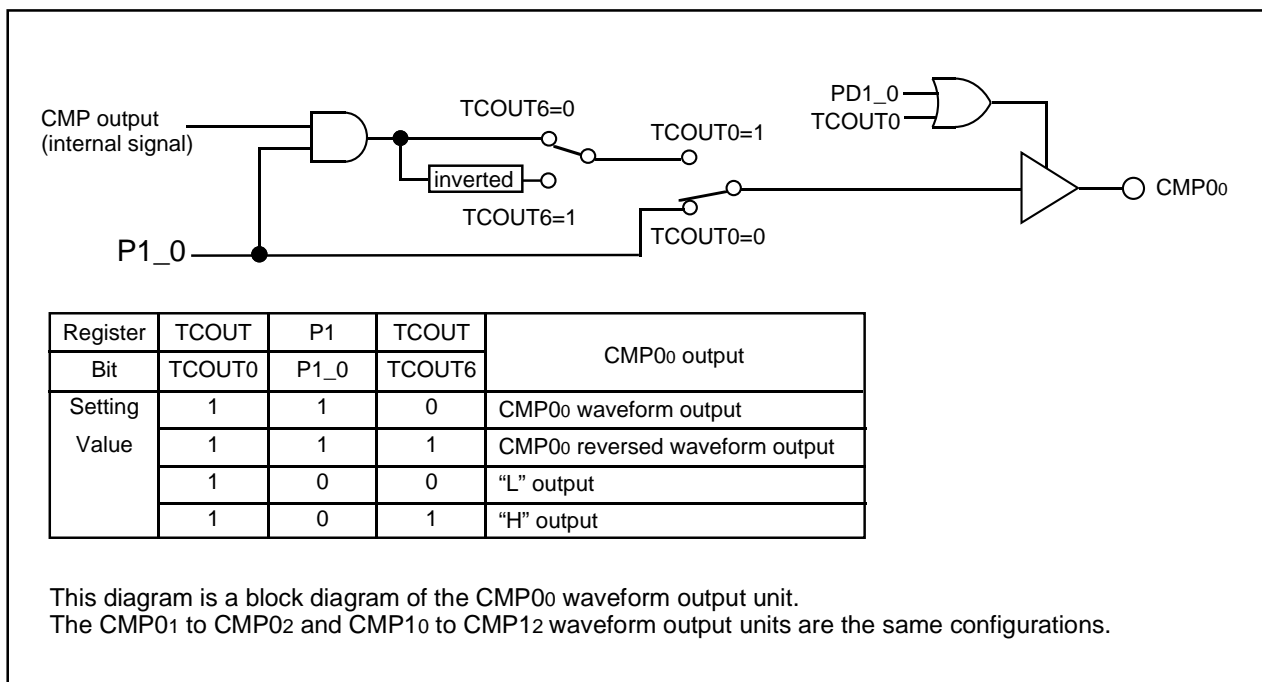

Figure 12.30 CMP Waveform Output Unit

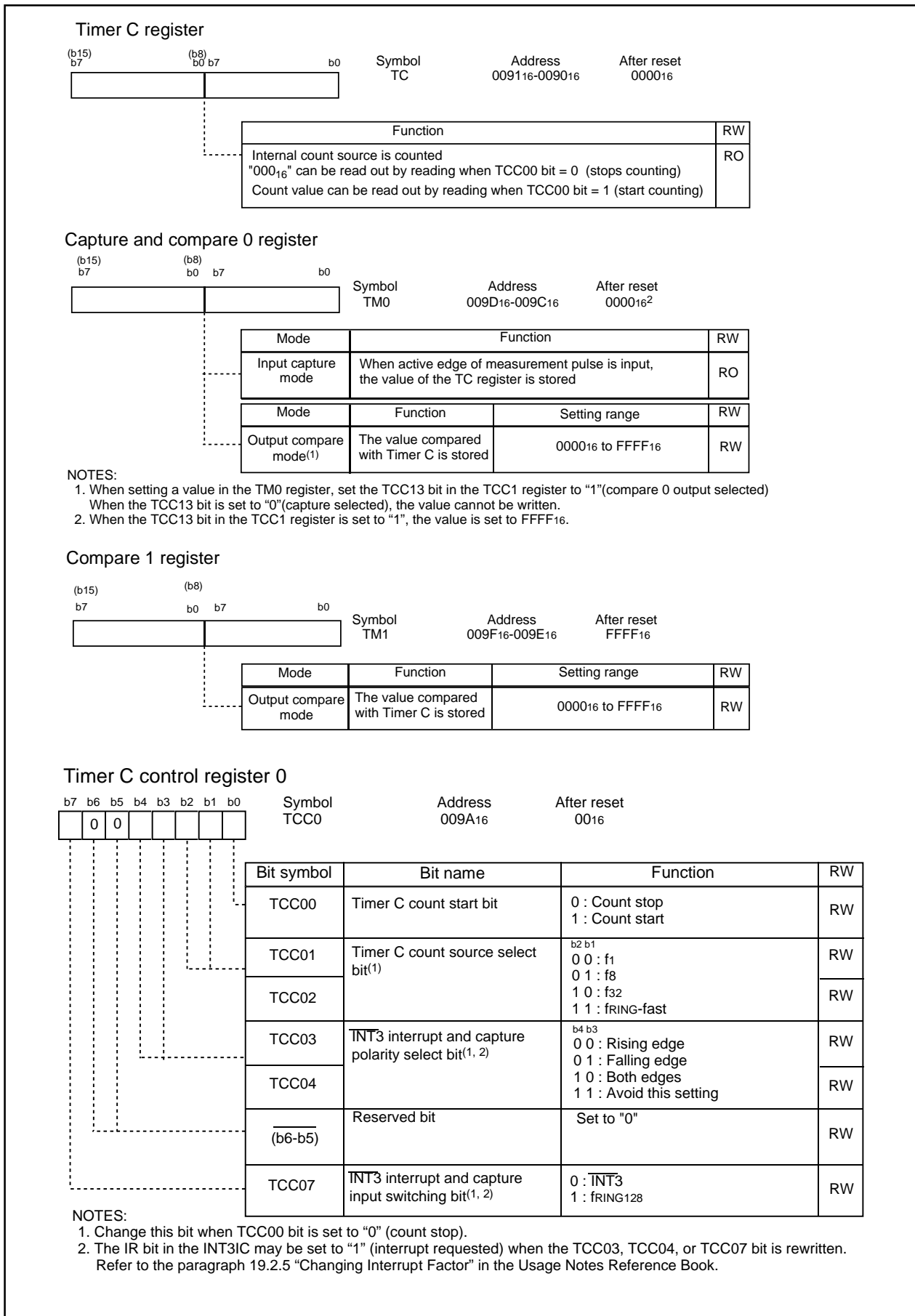

Figure 12.31 TC Register, TM0 Register, TM1 Register, TCC0 Register

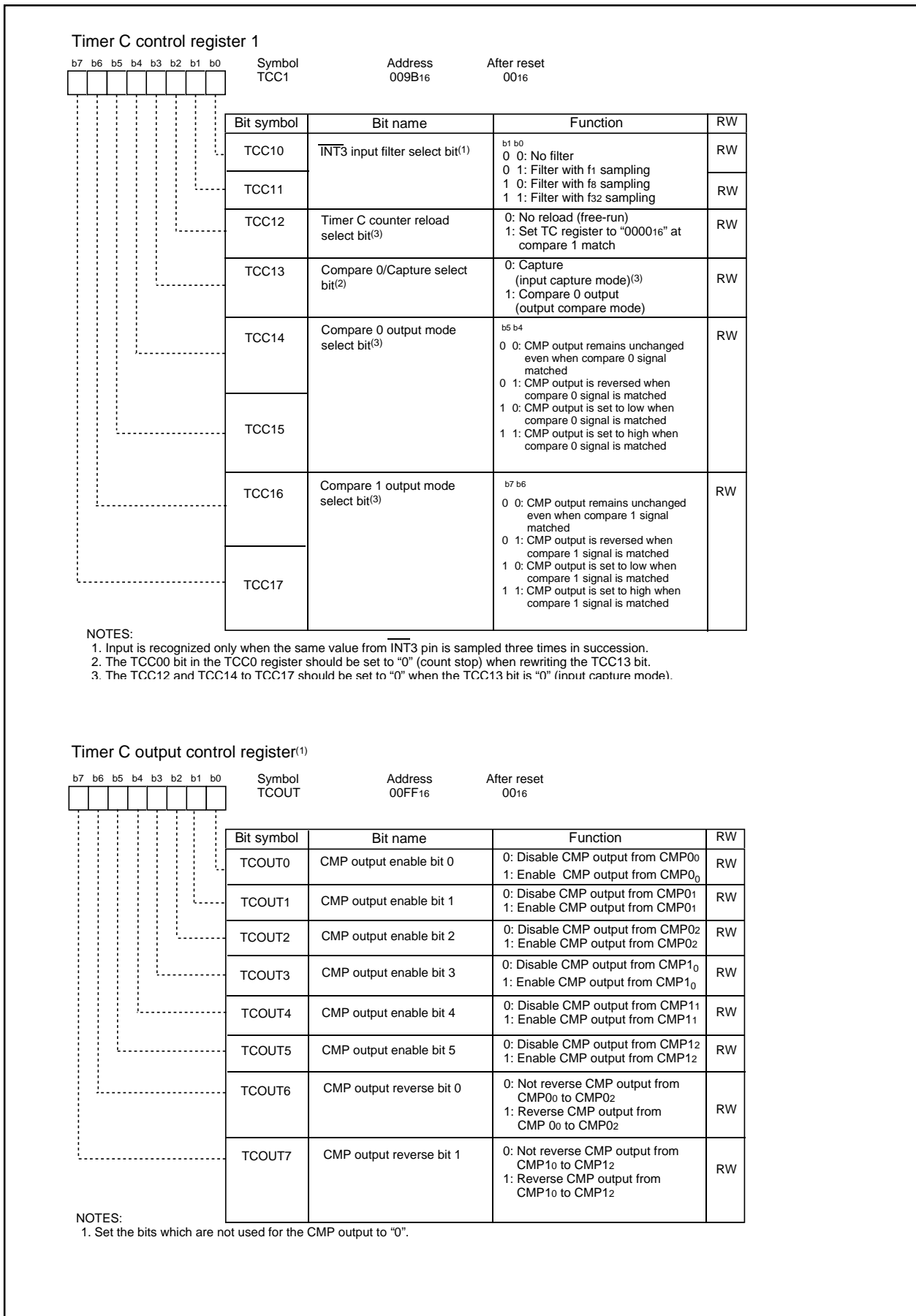

Figure 12.32 TCC1 Register and TCOU Register

### 12.4.1 Input Capture Mode

This mode uses an edge input to TCIN pin or the fRING128 clock as trigger to latch the timer value and generates an interrupt request. The TCIN input has a digital filter and this prevents an error caused by noise or so on from occurring. Table 12.13 shows specifications in input capture mode. Figure 12.33 shows an operation example of input capture mode.

**Table 12.13 Input Capture Mode Specifications**

Item	Specification
Count source	f1, f8, f32, fRING-fast
Count operation	<ul style="list-style-type: none"> <li>Count up</li> <li>Transfer value in TC register to TM0 register at active edge of measurement pulse</li> <li>Value in TC register is set to "0000<sub>16</sub>" when a counting stops</li> </ul>
Count start condition	TCC00 bit in TCC0 register is set to "1" (count start)
Count stop condition	TCC00 bit in TCC0 register is set to "0" (count stop)
Interrupt request generation timing	<ul style="list-style-type: none"> <li>When active edge of measurement pulse is input [INT3 interrupt]<sup>(2)</sup></li> <li>When Timer C overflows [Timer C interrupt]</li> </ul>
INT3/TCIN pin function	Programmable I/O port or measurement pulse input (INT3 interrupt input)
P10 to P12, P33 to P35 pin function	Programmable I/O port
Counter value reset timing	When TCC00 bit in TCC0 register is set to "0" (capture disabled)
Read from timer <sup>(1)</sup>	<ul style="list-style-type: none"> <li>Count value can be read out by reading TC register.</li> <li>Count value at measurement pulse active edge input can be read out by reading TM0 register.</li> </ul>
Write to timer	Write to TC register and TM0 register is disabled
Select function	<ul style="list-style-type: none"> <li>INT3/TCIN polarity select function Measurement pulse active edge is selected by TCC03 to TCC04 bits</li> <li>Digital filter function Digital filter sampling frequency is selected by TCC11 to TCC10 bits</li> <li>Trigger select function TCIN input or fRING128 is selected by TCC07 bit.</li> </ul>

**NOTES:**

1. TC register and TM0 register must be read in 16-bit units.
2. The INT3 interrupt is acknowledged by digital filter delay and one count source cycle delay (max.)

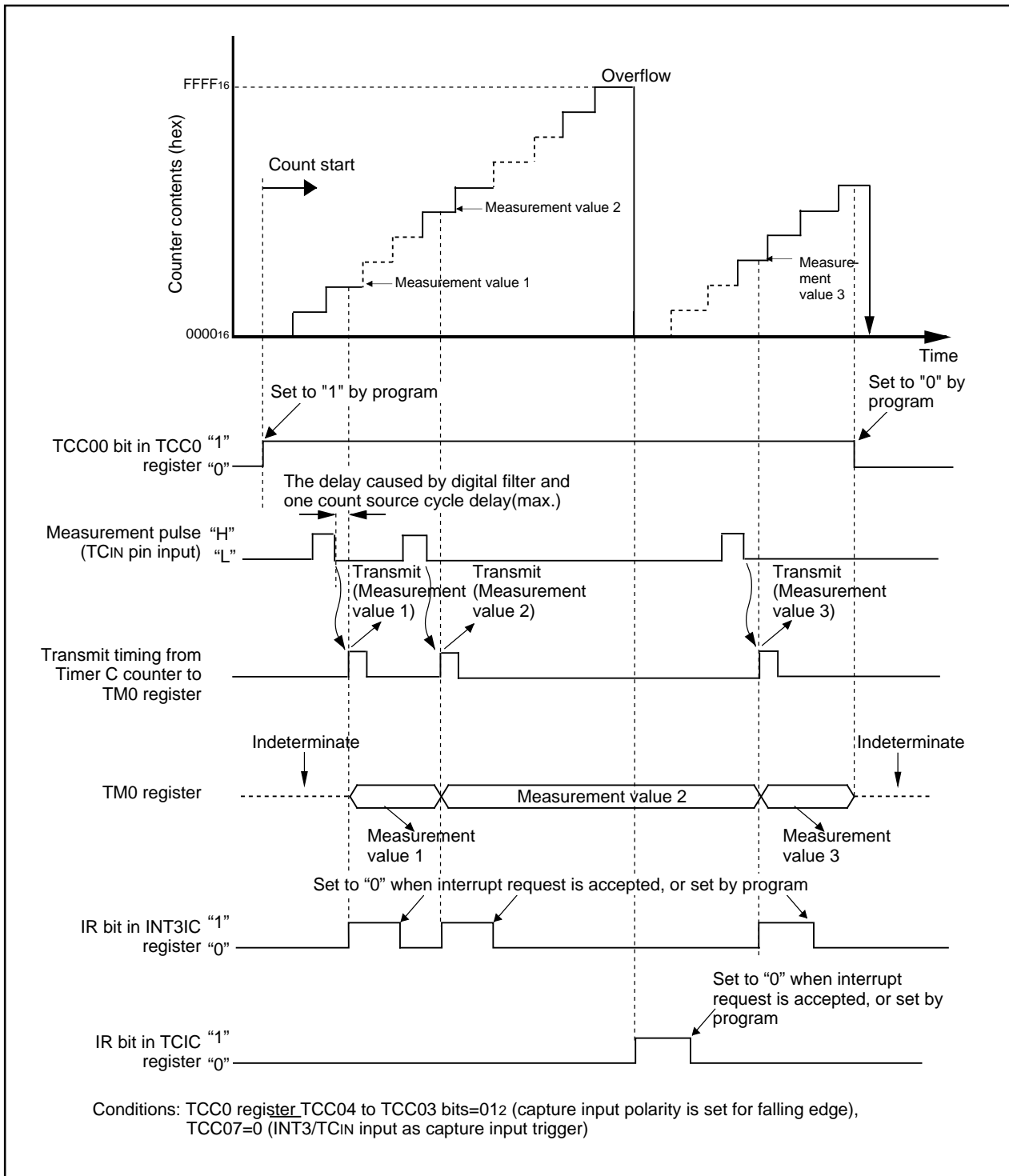

Figure 12.33 Operation Example of Timer C in Input Capture Mode

### 12.4.2 Output Compare Mode

In this mode, an interrupt request is generated when the value of TC register matches the value of TM0 or TM1 register. Table 12.14 shows specifications in output compare mode. Figure 12.34 shows an operation example of output compare mode.

**Table 12.14 Output Compare Mode Specifications**

Item	Specification
Count source	f1, f8, f32, fRING-fast
Count operation	<ul style="list-style-type: none"> <li>Count up</li> <li>Value in TC register is set to "0000<sub>16</sub>" when a counting stops</li> </ul>
Count start condition	TCC00 bit in TCC0 register is set to "1" (count start)
Count stop condition	TCC00 bit in TCC0 register is set to "0" (count stop)
Waveform output start condition	When "1" (CMP output enabled) is written to TCOUT0 to TCOUT5 bits. <sup>(2)</sup>
Waveform output stop condition	When "0" (CMP output disabled) is written to TCOUT0 to TCOUT5 bits.
Interrupt request generation timing	<ul style="list-style-type: none"> <li>When a match occurs in compare circuit 0 [compare 0 interrupt]</li> <li>When a match occurs in compare circuit 1 [compare 1 interrupt]</li> <li>When Time C overflows [Timer C interrupt]</li> </ul>
INT3/TCIN pin function	Programmable I/O port or INT3 interrupt input
P10 to P12 pins and P30 to P32 pins function	Programmable I/O port or CMP output <sup>(2)</sup>
Counter value reset timing	When TCC00 bit in TCC0 register is set to "0" (count stop)
Read from timer <sup>(1)</sup>	<ul style="list-style-type: none"> <li>Value in compare register can be read out by reading TM0 register and TM1 register.</li> <li>Count value can be read out by reading TC register.</li> </ul>
Write to timer <sup>(1)</sup>	<ul style="list-style-type: none"> <li>Write to TC register is disabled.</li> <li>Values written to TM0 register and TM1 register are stored in compare register at the following timings: <ul style="list-style-type: none"> <li>When TM0 and TM1 registers are written if TCC00 bit is "0" (count stop)</li> <li>When counter overflows if TCC00 bit is "1" (in counting) and TCC12 bit in TCC1 register is "0" (free-run)</li> <li>When compare 1 matches counter if TCC00 bit is "1" and TCC12 bit is "1" (set TC register to "0000<sub>16</sub>" at compare 1 match)</li> </ul> </li> </ul>
Select function	<ul style="list-style-type: none"> <li>Timer C counter reload select function Counter value in TC register at match occurrence in compare circuit 1 is set or not set to "0000<sub>16</sub>" selected by TCC12 bit in TCC1 register.</li> <li>Output level at match occurrence in compare circuit 0 can be selected by TCC15 to TCC14 bits in TCC1 register. Similarly, output level at match occurrence in compare circuit 1 can be selected by TCC17 to TCC16 bits in TCC1 register.</li> <li>Whether output is reversed or not can be selected by TCOUT6 to TCOUT7 bits in TCOUT register.</li> </ul>

**NOTES:**

1. TC, TM0, and TM1 registers should be accessed in 16-bit units.
2. When the corresponding port data is "1", the waveform is output depending on the setting of the registers TCC1 and TCOUT. When the corresponding port data is "0", the fixed level is output (refer to Figure 12.30 CMP Waveform Output Unit).

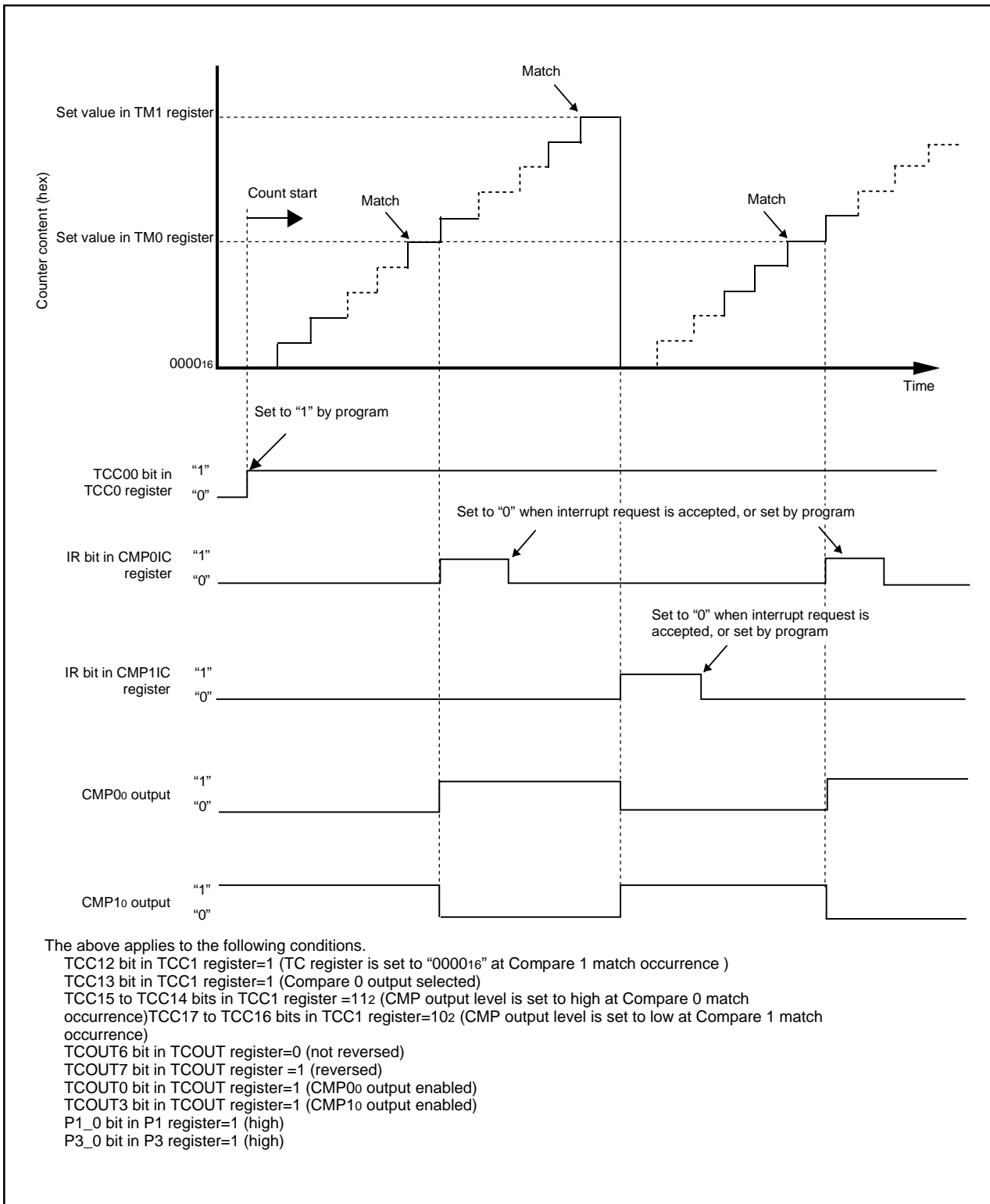

**Figure 12.34 Operation Example of Timer C in Output Compare Mode**





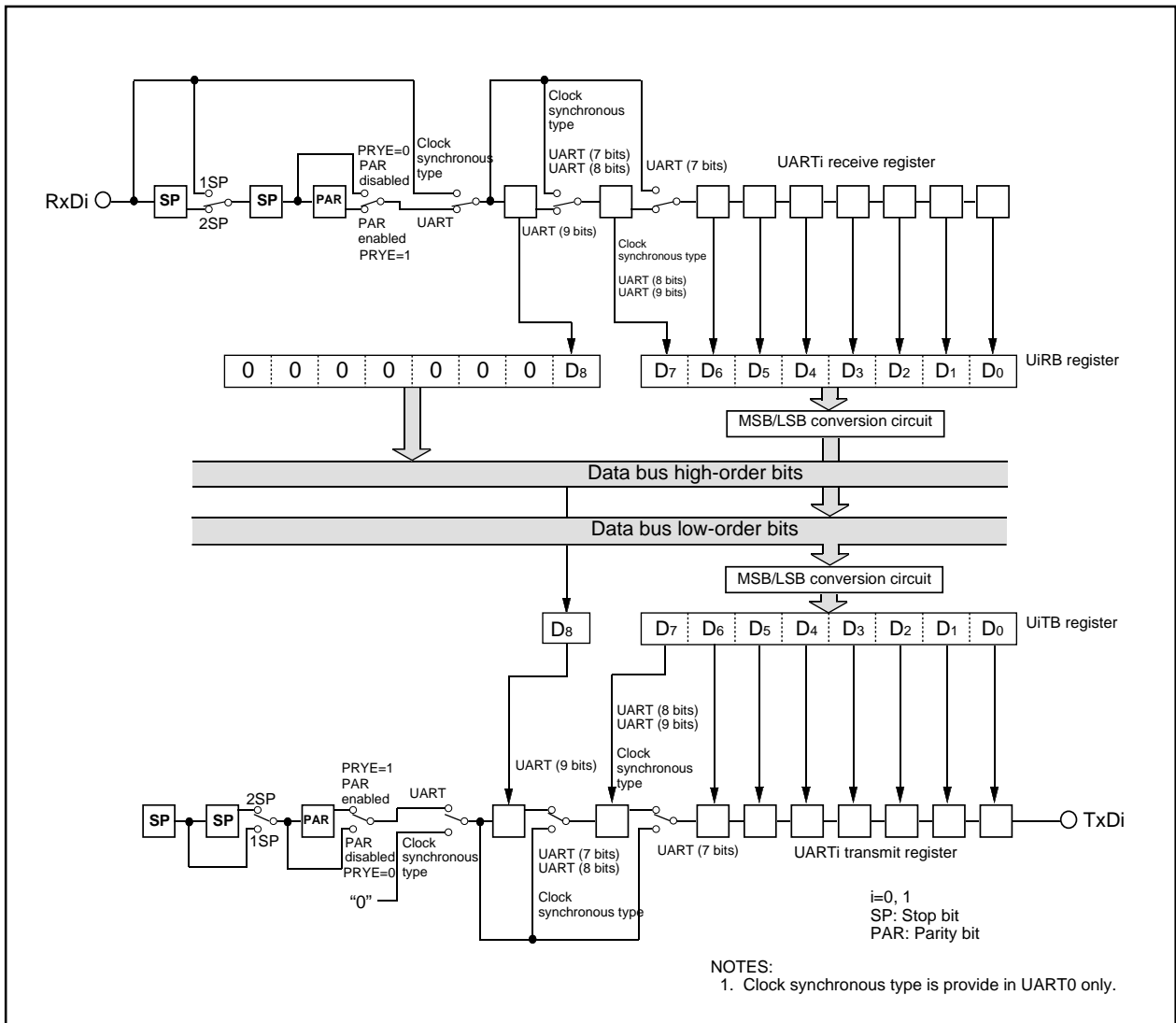

Figure 13.2 UARTi Transmit/Receive Unit

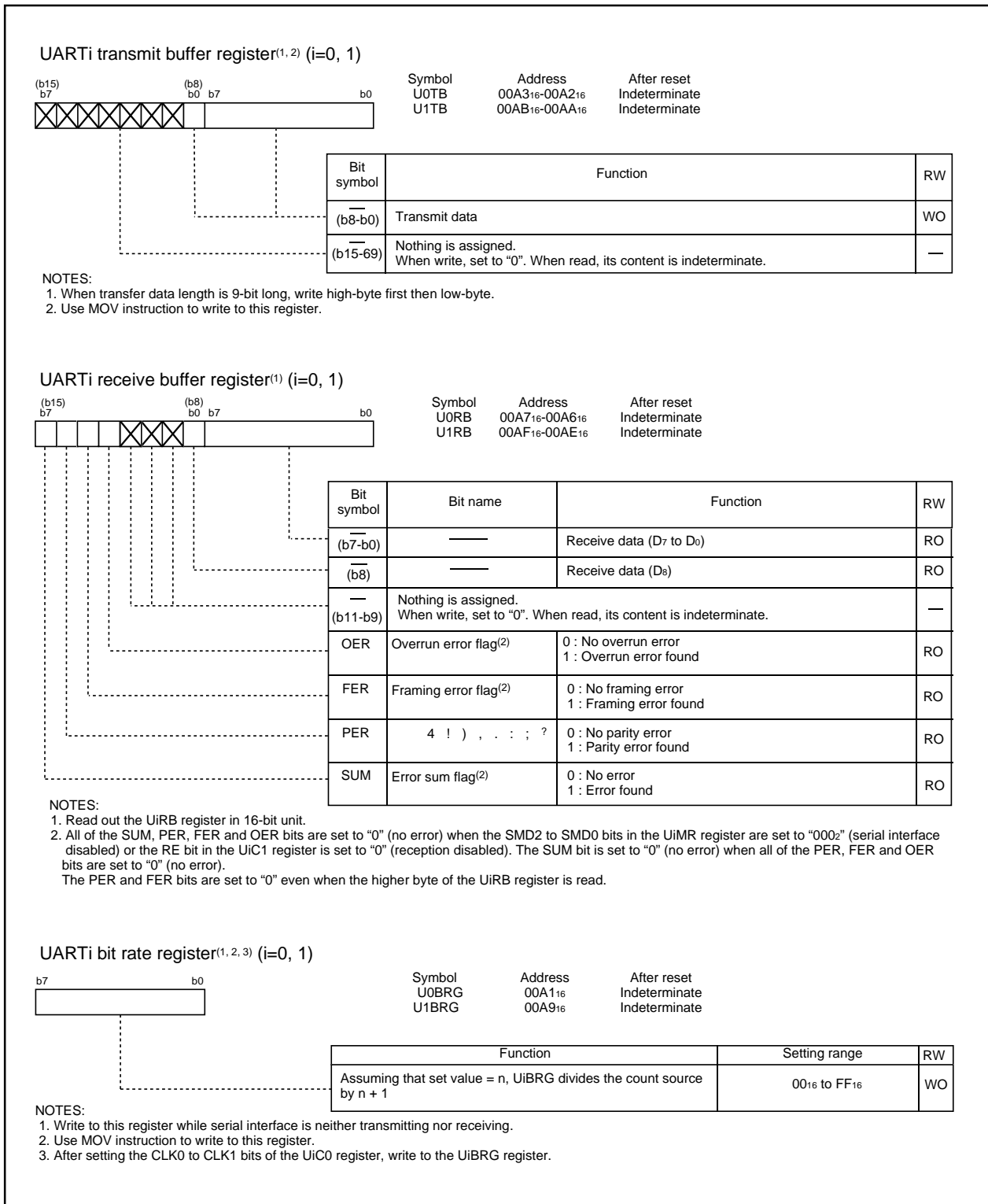

Figure 13.3 U0TB and U1TB Registers, U0RB and U1RB Registers, and U0BRG and U1BRG Registers

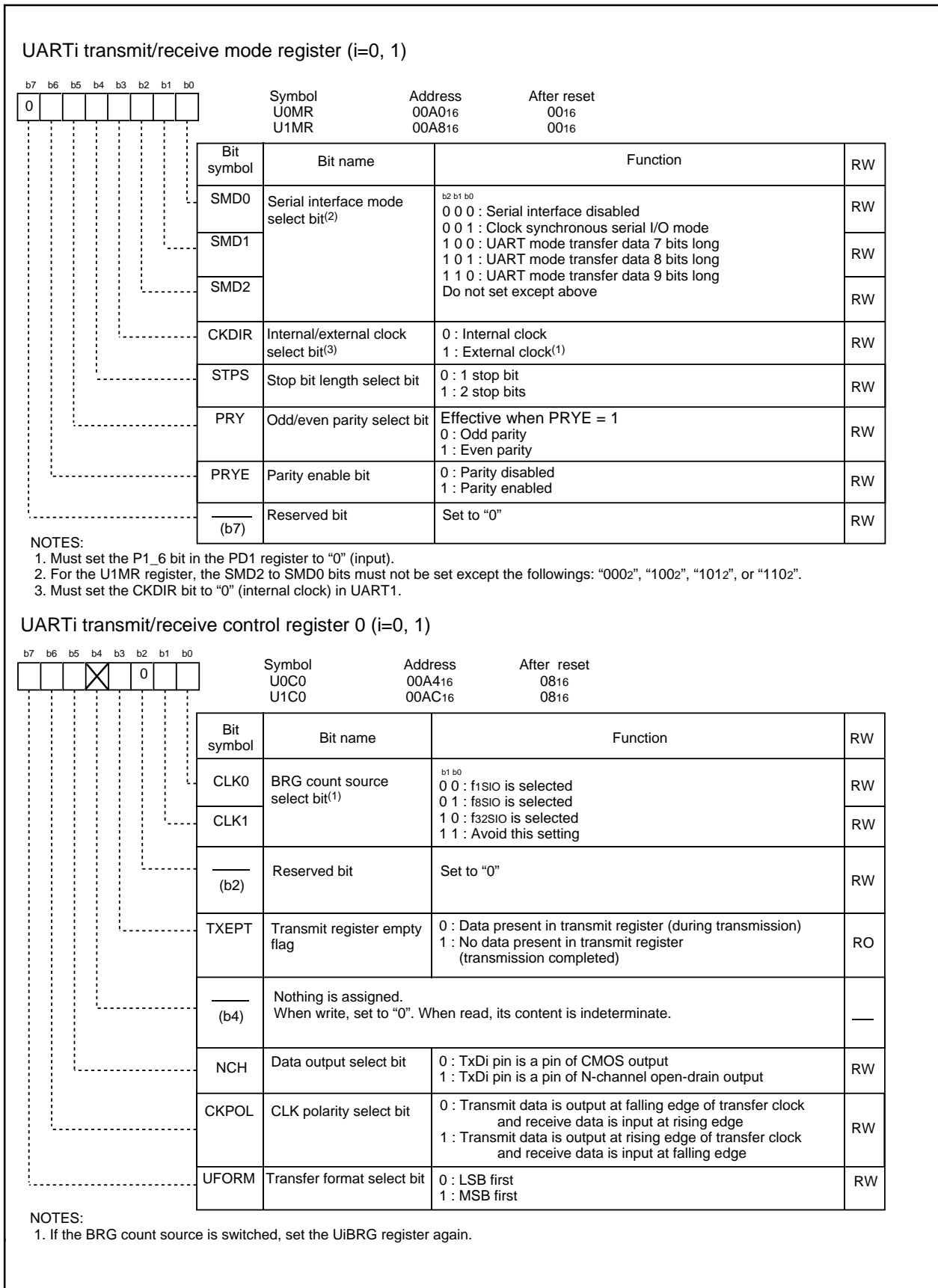

Figure 13.4 U0MR and U1MR Registers and U0C0 and U1C0 Registers

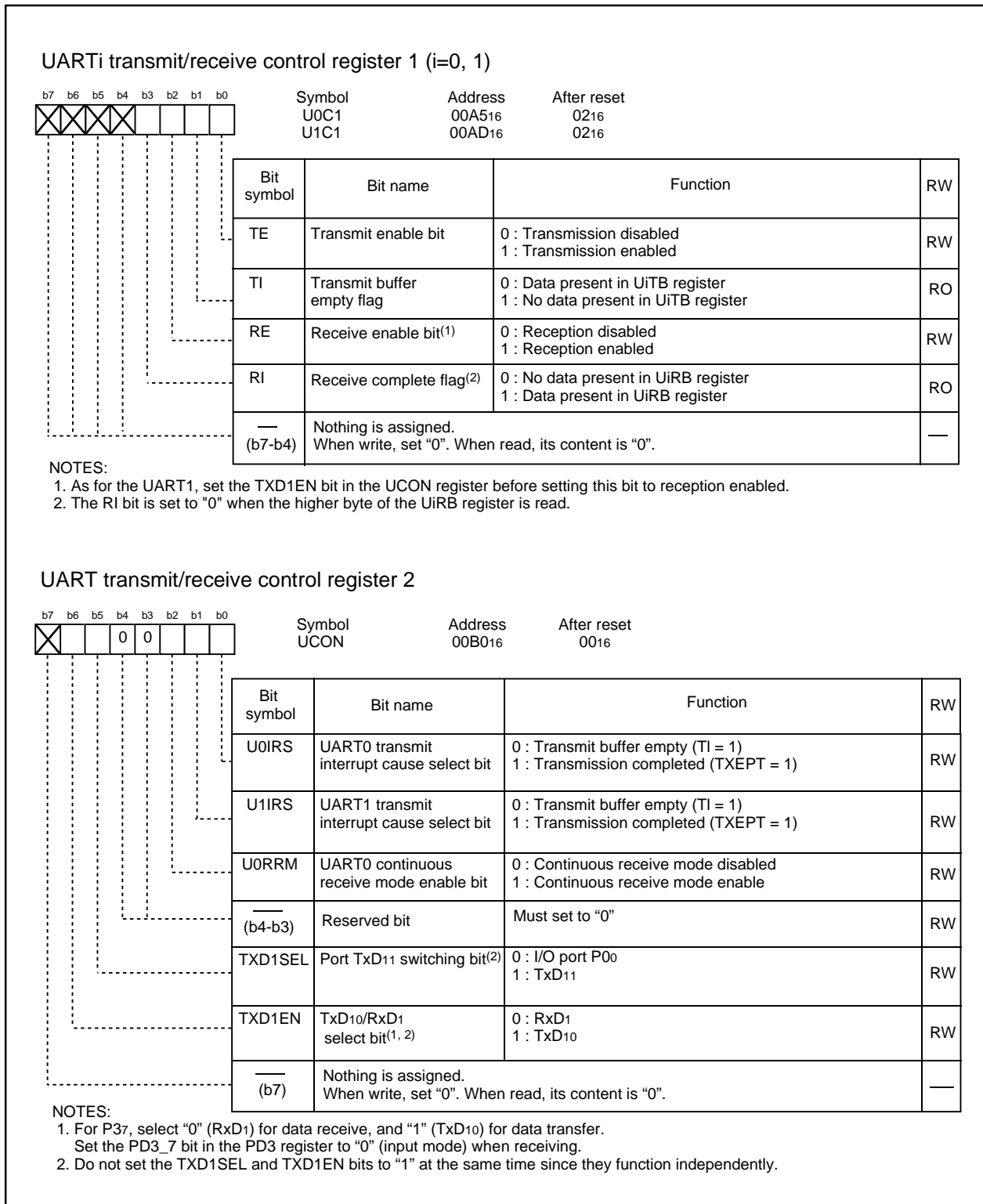

Figure 13.5 U0C1 and U1C1 Registers and UCON Register

### 13.1 Clock Synchronous Serial I/O Mode

The clock synchronous serial I/O mode uses a transfer clock to transmit and receive data. This mode can be selected with UART0. Table 13.1 lists the specifications of the clock synchronous serial I/O mode. Table 13.2 lists the registers used in clock synchronous serial I/O mode and the register values set.

**Table 13.1 Clock Synchronous Serial I/O Mode Specifications**

Item	Specification
Transfer data format	<ul style="list-style-type: none"> <li>Transfer data length: 8 bits</li> </ul>
Transfer clock	<ul style="list-style-type: none"> <li>CKDIR bit in U0MR register is set to "0" (internal clock): <math>f_i/(2(n+1))</math>  <math>f_i=f_{1SIO}, f_{8SIO}, f_{32SIO}</math>    <math>n</math>=setting value in UiBRG register: 00<sub>16</sub> to FF<sub>16</sub></li> <li>CKDIR bit is set to "1" (external clock): input from CLK0 pin</li> </ul>
Transmission start condition	<ul style="list-style-type: none"> <li>Before transmission can start, the following requirements must be met<sup>(1)</sup> <ul style="list-style-type: none"> <li>TE bit in U0C1 register is set to "1" (transmission enabled)</li> <li>TI bit in U0C1 register is set to "0" (data present in U0TB register)</li> </ul> </li> </ul>
Reception start condition	<ul style="list-style-type: none"> <li>Before reception can start, the following requirements must be met<sup>(1)</sup> <ul style="list-style-type: none"> <li>RE bit in U0C1 register is set to "1" (reception enabled)</li> <li>TE bit in U0C1 register is set to "1" (transmission enabled)</li> <li>TI bit in U0C1 register is set to "0" (data present in the U0TB register)</li> </ul> </li> </ul>
Interrupt request generation timing	<ul style="list-style-type: none"> <li>For transmission, one of the following conditions can be selected <ul style="list-style-type: none"> <li>U0IRS bit is set to "0" (transmit buffer empty): when transferring data from U0TB register to UART0 transmit register (at start of transmission)</li> <li>U0IRS bit is set to "1" (transfer completed): when serial interface finished sending data from UARTi transmit register</li> </ul> </li> <li>For reception <ul style="list-style-type: none"> <li>When transferring data from the UART0 receive register to the U0RB register (at completion of reception)</li> </ul> </li> </ul>
Error detection	<ul style="list-style-type: none"> <li>Overrun error<sup>(2)</sup>  This error occurs if serial interface started receiving the next data before reading the U0RB register and received the 7th bit of the next data</li> </ul>
Select function	<ul style="list-style-type: none"> <li>CLK polarity selection  Transfer data I/O can be chosen to occur synchronously with the rising or the falling edge of the transfer clock</li> <li>LSB first, MSB first selection  Whether to start sending/receiving data beginning with bit 0 or beginning with bit 7 can be selected</li> <li>Continuous receive mode selection  Reception is enabled immediately by reading the U0RB register</li> </ul>

**NOTES:**

- When an external clock is selected, the conditions must be met while if the U0C0 register0 CKPOL bit = 0 (transmit data output at the falling edge and the receive data taken in at the rising edge of the transfer clock), the external clock is in the high state; if the CKPOL bit in the U0C0 register is set to "1" (transmit data output at the rising edge and the receive data taken in at the falling edge of the transfer clock), the external clock is in the low state.
- If an overrun error occurs, the value of U0RB register will be indeterminate. The IR bit of S0RIC register does not change.

**Table 13.2 Registers to Be Used and Settings in Clock Synchronous Serial I/O Mode**

Register	Bit	Function
U0TB	0 to 7	Set transmission data
U0RB	0 to 7	Reception data can be read
	OER	Overrun error flag
U0BRG	0 to 7	Set a bit rate
U0MR	SMD2 to SMD0	Set to "0012"
	CKDIR	Select the internal clock or external clock
U0C0	CLK1 to CLK0	Select the count source for the U0BRG register
	TXEPT	Transmit register empty flag
	NCH	Select TxD0 pin output mode
	CKPOL	Select the transfer clock polarity
	UFORM	Select the LSB first or MSB first
U0C1	TE	Set this bit to "1" to enable transmission/reception
	TI	Transmit buffer empty flag
	RE	Set this bit to "1" to enable reception
	RI	Reception complete flag
UCON	U0IRS	Select the source of UART0 transmit interrupt
	U0RRM	Set this bit to "1" to use continuous receive mode
	TXDISEL	Set to "0"
	TXDIEN	Set to "0"

**NOTES:**

1. Not all register bits are described above. Set those bits to "0" when writing to the registers in clock synchronous serial I/O mode.

Table 13.3 lists the functions of the I/O pins during clock synchronous serial I/O mode. Note that for a period from when the UART0 operation mode is selected to when transfer starts, the TxD0 pin outputs an "H". (If the NCH bit is set to "1"(N-channel open-drain output), this pin is in high-impedance state.)

**Table 13.3 Pin Functions**

Pin name	Function	Method of selection
TxD0 (P14)	Serial data output	(Outputs dummy data when performing reception only)
RxD0 (P15)	Serial data input	PD1 register PD1_5 bit=0 (P15 can be used as an input port when performing transmission only)
CLK0 (P16)	Transfer clock output	U0MR register CKDIR bit=0
	Transfer clock input	U0MR register CKDIR bit=1 PD1 register PD1_6 bit=0

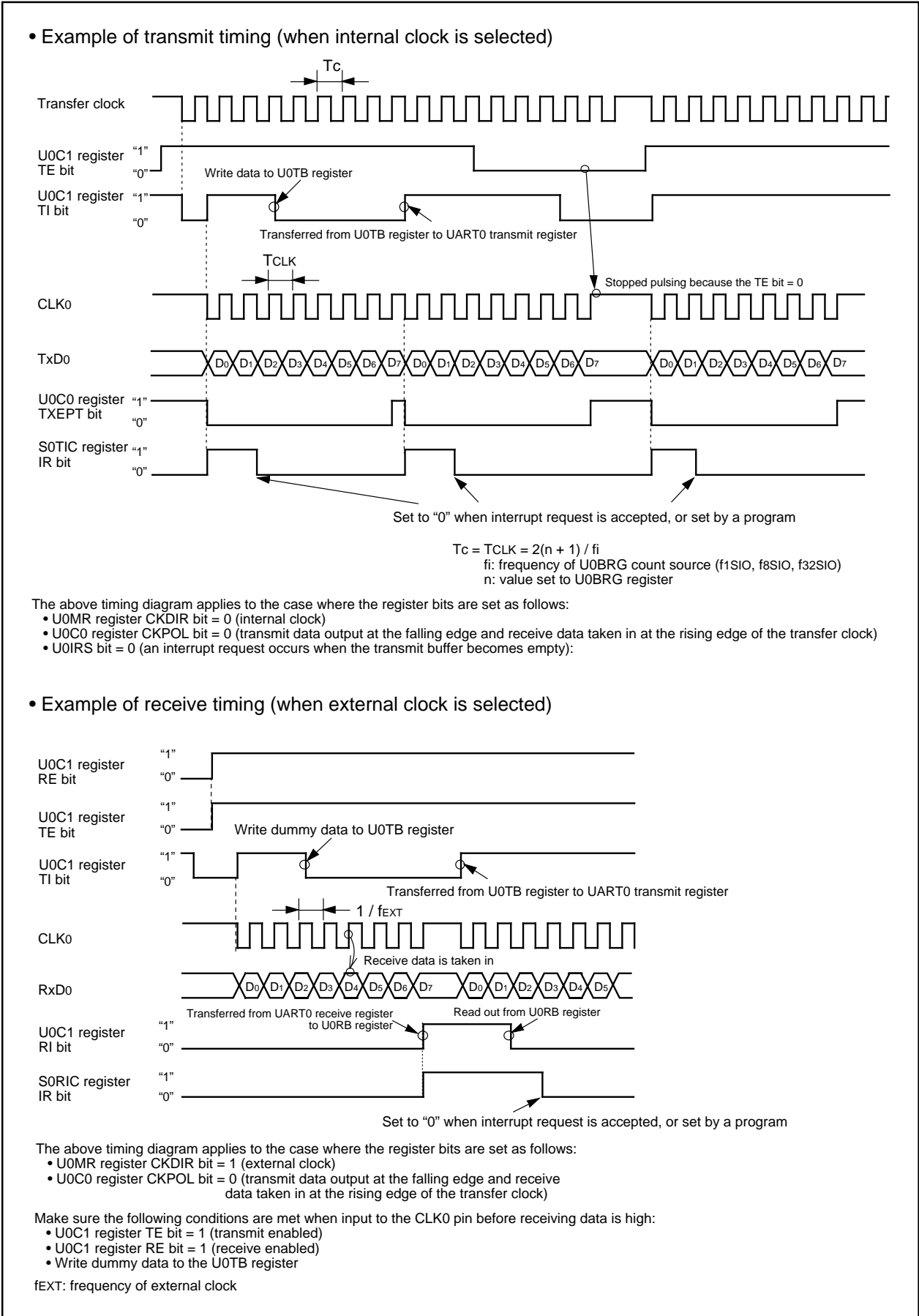
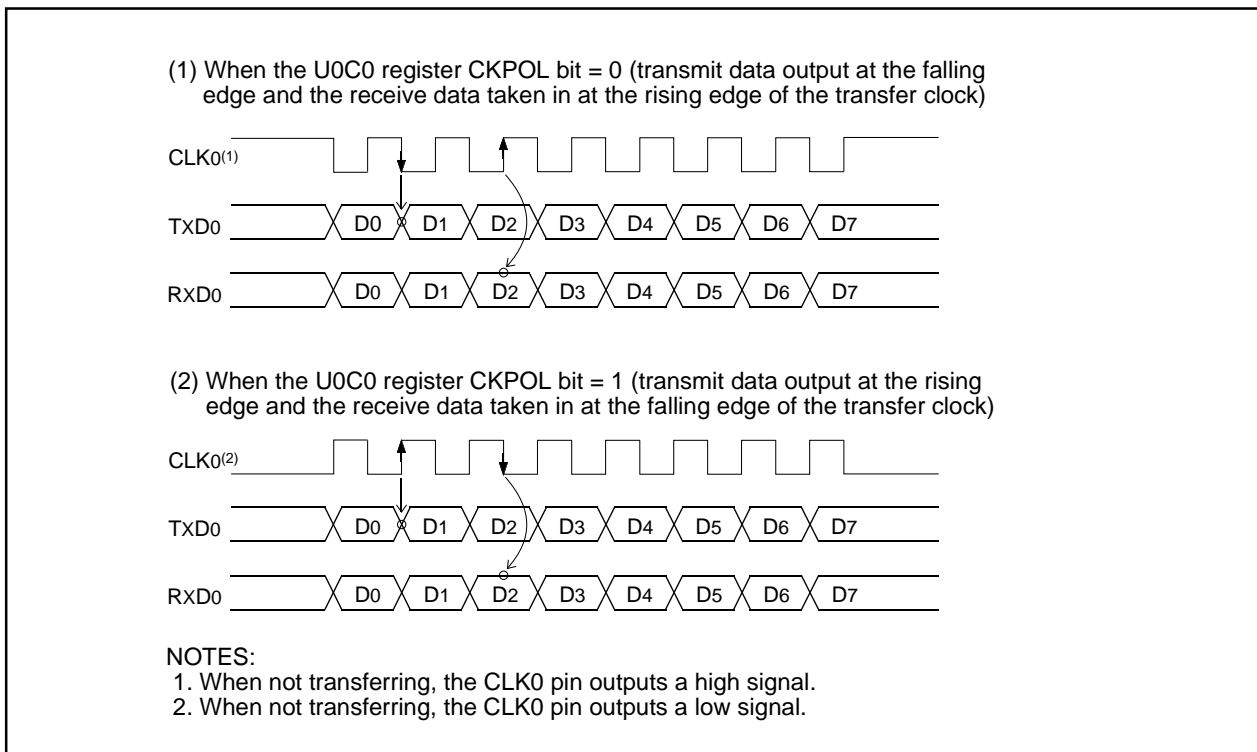

Figure 13.6 Transmit and Receive Operation

### 13.1.1 Polarity Select Function

Figure 13.7 shows the polarity of the transfer clock. Use the CKPOL bit in the U0C0 register to select the transfer clock polarity.



**Figure 13.7 Transfer Clock Polarity**

### 13.1.2 LSB First/MSB First Select Function

Figure 13.8 shows the transfer format. Use the UFORM bit in the U0C0 register to select the transfer format.

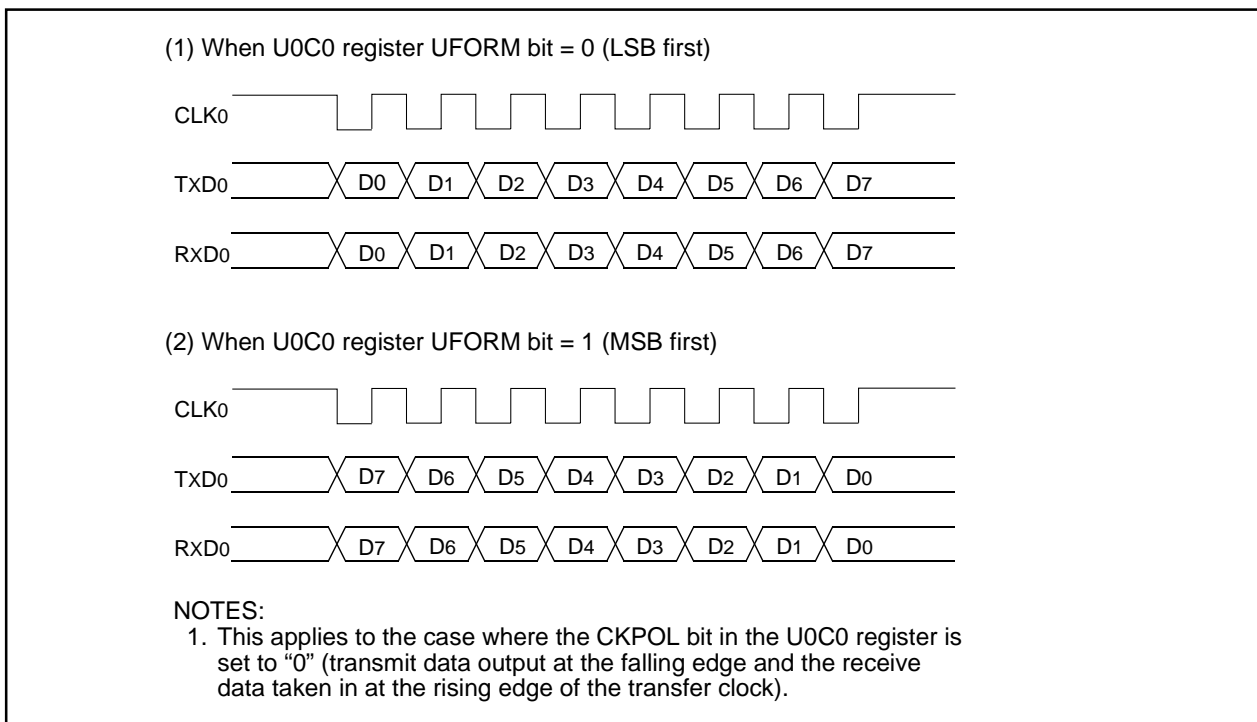

**Figure 13.8 Transfer Format**



### 13.1.3 Continuous Receive Mode

Continuous receive mode is held by setting setting the U0RRM bit in the UCON register to “1” (enables continuous receive mode). In this mode, reading the U0RB register sets the TI bit in the U0C1 register to “0”(data in the U0TB register). When the U0RRM bit is set to “1”, do not write dummy data to tge U0TB register in a program.

## 13.2 Clock Asynchronous Serial I/O (UART) Mode

The UART mode allows transmitting and receiving data after setting the desired bit rate and transfer data format. Tables 13.4 lists the specifications of the UART mode. Table 13.5 lists the registers and settings for UART mode.

**Table 13.4 UART Mode Specifications**

Item	Specification
Transfer data format	<ul style="list-style-type: none"> <li>• Character bit (transfer data): selectable from 7, 8 or 9 bits</li> <li>• Start bit: 1 bit</li> <li>• Parity bit: selectable from odd, even, or none</li> <li>• Stop bit: selectable from 1 or 2 bits</li> </ul>
Transfer clock	<ul style="list-style-type: none"> <li>• UiMR(i=0, 1) register CKDIR bit = 0 (internal clock) : <math>f_j/(16(n+1))</math>  <math>f_j=f_{1SIO}, f_{8SIO}, f_{32SIO}</math> n=setting value in UiBRG register: 00<sub>16</sub> to FF<sub>16</sub></li> <li>• CKDIR bit = "1" (external clock) : <math>f_{EXT}/(16(n+1))</math>  <math>f_{EXT}</math>: input from CLKi pin n=setting value in UiBRG register: 00<sub>16</sub> to FF<sub>16</sub></li> </ul>
Transmission start condition	<ul style="list-style-type: none"> <li>• Before transmission can start, the following requirements must be met               <ul style="list-style-type: none"> <li>– TE bit in UiC1 register= 1 (transmission enabled)</li> <li>– TI bit in UiC1 register = 0 (data present in UiTB register)</li> </ul> </li> </ul>
Reception start condition	<ul style="list-style-type: none"> <li>• Before reception can start, the following requirements must be met               <ul style="list-style-type: none"> <li>– RE bit in UiC1 register= 1 (reception enabled)</li> <li>– Start bit detection</li> </ul> </li> </ul>
Interrupt request generation timing	<ul style="list-style-type: none"> <li>• For transmission, one of the following conditions can be selected               <ul style="list-style-type: none"> <li>– UiIRS bit = 0 (transmit buffer empty): when transferring data from UiTB register to UARTi transmit register (at start of transmission)</li> <li>– UiIRS bit =1 (transfer completed): when serial interface finished sending data from UARTi transmit register</li> </ul> </li> <li>• For reception                When transferring data from UARTi receive register to UiRB register (at completion of reception)</li> </ul>
Error detection	<ul style="list-style-type: none"> <li>• Overrun error<sup>(1)</sup>                This error occurs if serial interface started receiving the next data before reading UiRB register and received the bit one before the last stop bit of the next data</li> <li>• Framing error                This error occurs when the number of stop bits set is not detected</li> <li>• Parity error                This error occurs when if parity is enabled, the number of 1's in parity and character bits does not match the number of 1's set</li> <li>• Error sum flag                This flag is set (= 1) when any of the overrun, framing, and parity errors is encountered</li> </ul>
Select function	<ul style="list-style-type: none"> <li>• TXD10, RXD1 selection (UART)                P37 pin can be used as RXD1 pin or TXD10 pin in UART1. Select by a program.</li> <li>• TXD11 pin selection (UART1)                P00 pin can be used as TXD11 pin in UART1 or port P00. Select by a program.</li> </ul>

**NOTES:**

1. If an overrun error occurs, the value of UORB register will be indeterminate. The IR bit in the SORIC register does not change.

**Table 13.5 Registers to Be Used and Settings in UART Mode**

Register	Bit	Function
UiTB	0 to 8	Set transmission data <sup>(1)</sup>
UiRB	0 to 8	Reception data can be read <sup>(1)</sup>
	OER,FER,PER,SUM	Error flag
UiBRG	0 to 7	Set a bit rate
UiMR	SMD2 to SMD0	Set these bits to '1002' when transfer data is 7 bits long Set these bits to '1012' when transfer data is 8 bits long Set these bits to '1102' when transfer data is 9 bits long
	CKDIR	Select the internal clock or external clock <sup>(2)</sup>
	STPS	Select the stop bit
	PRY, PRYE	Select whether parity is included and whether odd or even
UiC0	CLK0, CLK1	Select the count source for the UiBRG register
	TXEPT	Transmit register empty flag
	NCH	Select TxDi pin output mode
	CKPOL	Set to "0"
	UFORM	LSB first or MSB first can be selected when transfer data is 8 bits long. Set this bit to "0" when transfer data is 7 or 9 bits long.
UiC1	TE	Set this bit to "1" to enable transmission
	TI	Transmit buffer empty flag
	RE	Set this bit to "1" to enable reception
	RI	Reception complete flag
UCON	U0IRS, U1IRS	Select the source of UART0/UART1 transmit interrupt
	U0RRM	Set to "0"
	TXD1SEL	Select output pin for UART1 transfer data
	TXD1EN	Select TxD10 or RxD1 to be used

**NOTES:**

1. The bits used for transmit/receive data are as follows: Bit 0 to bit 6 when transfer data is 7 bits long; bit 0 to bit 7 when transfer data is 8 bits long; bit 0 to bit 8 when transfer data is 9 bits long.
2. An external clock can be selected in UART0 only.

Table 13.6 lists the functions of the I/O pins during UART mode. Note that for a period from when the UARTi operation mode is selected to when transfer starts, the TxDi pin outputs an "H". (If the NCH bit is set to "1"(N-channel open-drain output), this pin is in high-impedance state.)

**Table 13.6 I/O Pin Functions**

Pin name	Function	Method of selection
TxD0 (P14)	Serial data output	(Cannot be used as a port when performing reception only)
RxD0 (P15)	Serial data input	PD1 register PD1_5 bit=0 (Can be used as an input port when performing transmission only)
CLK0 (P16)	Programmable I/O port	U0MR register CKDIR bit=0
	Transfer clock input	U0MR register CKDIR bit=1 PD1 register PD1_6 bit=0
TxD10/RxD1 (P37)	Serial data output	TXD1EN=1
	Serial data input	TXD1EN=0, PD3 register PD3_7 bit=0
TxD11 (P00)	Serial data output	Serial data output, TXD1SEL=1

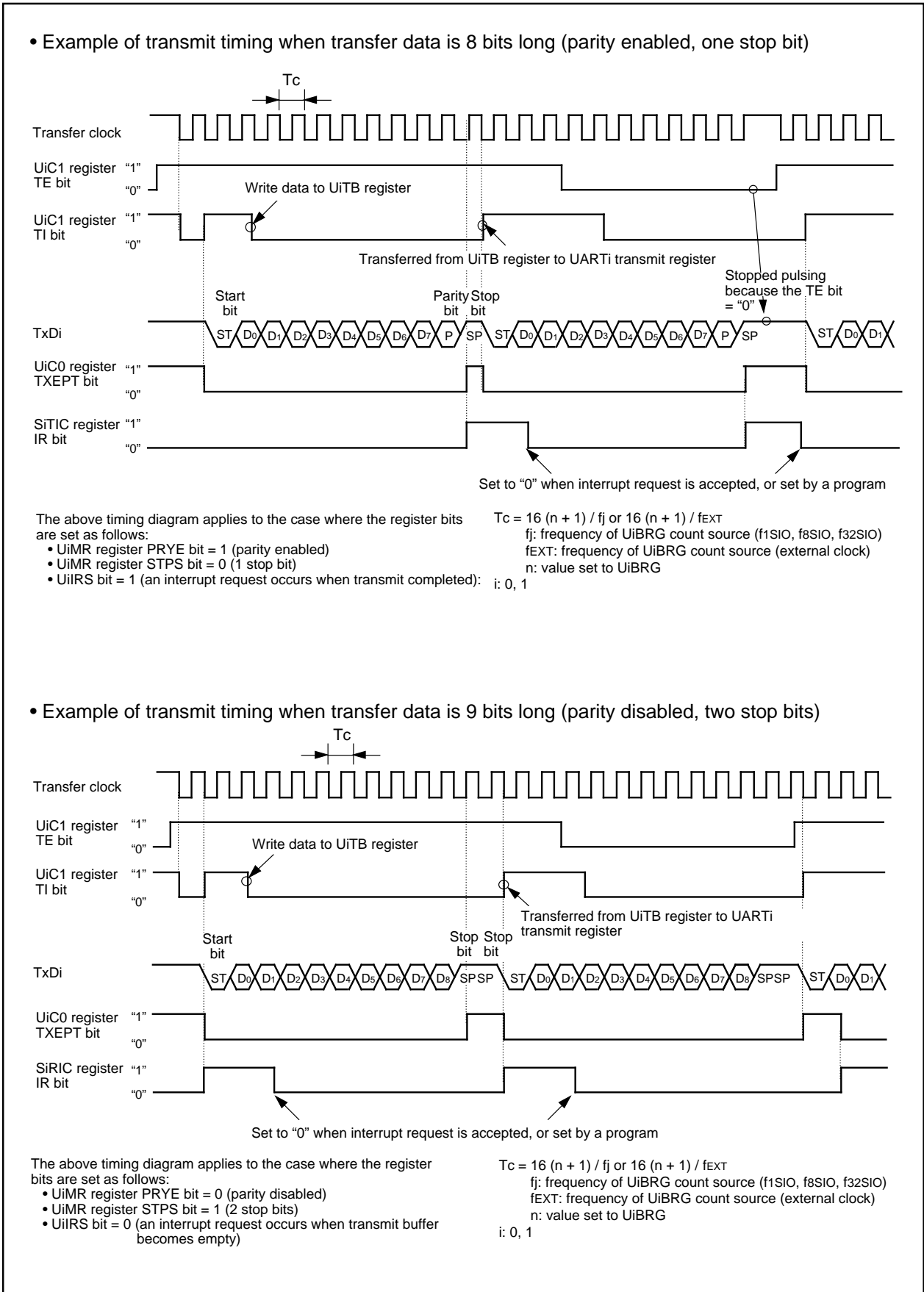
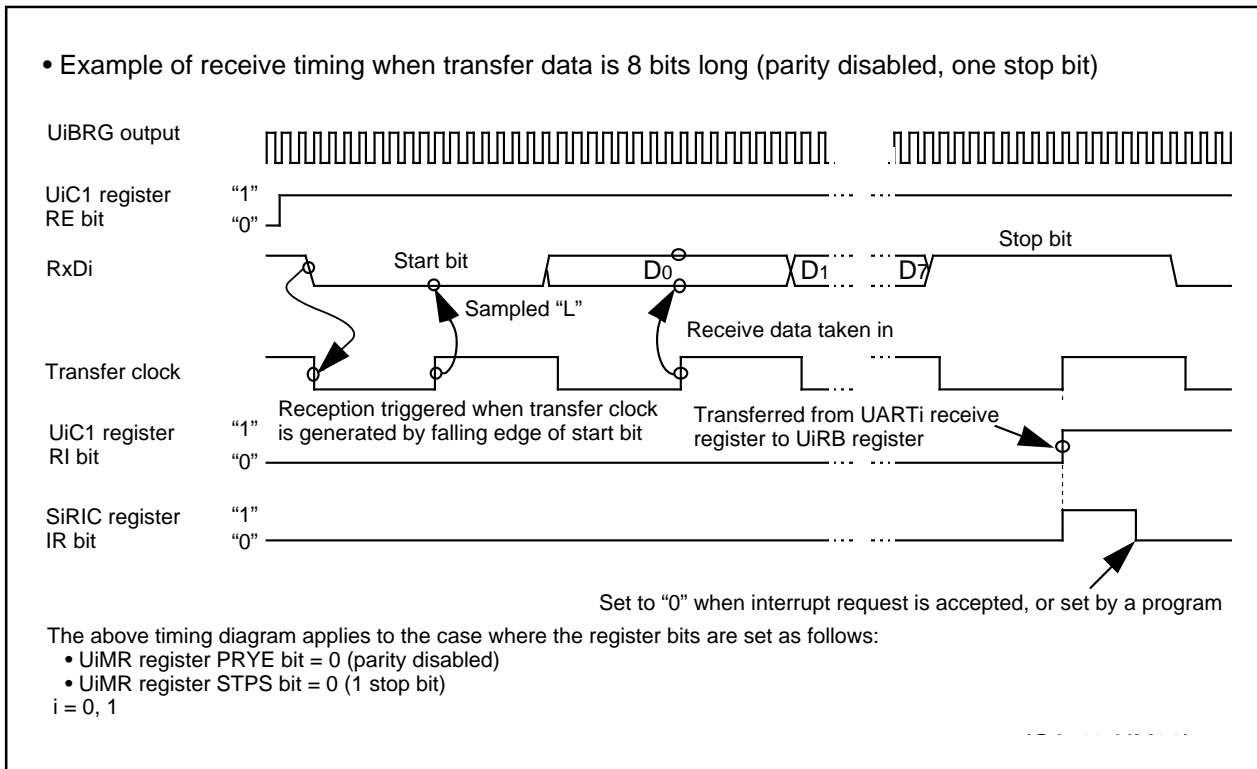

Figure 13.9 Transmit Operation



**Figure 13.10 Receive Operation**

### 13.2.1 TxD10/RxD1 Select Function (UART1)

P37 can be used as TxD10 output pin or RxD1 input pin by selecting with the TXD1EN bit in the UCON register. P37 is used as TxD10 output pin if the TXD1EN bit is set to "1" (TxD10) and used as RxD1 input pin if set to "0" (RxD1).

### 13.2.2 TxD11 Select Function (UART1)

P00 can be used as TxD11 output pin or a port by selecting with the TXD1SEL bit in the UCON register. P00 is used as TxD11 output pin if the TXD1SEL bit is set to "1" (TxD11) and used as an I/O port if set to "0" (P00).

### 13.2.3 Bit Rate

Divided-by-16 of frequency by the UiBRG (i=0 to 1) register in UART mode is a bit rate.

<UART Mode>

- When selecting internal clock  
 Setting value to the UiBRG register =  $\frac{f_j}{\text{Bit Rate} \times 16} - 1$

$f_j$  : Count source frequency of the UiBRG register (f1SIO, f8SIO and f32SIO)

- When selecting external clock  
 Setting value to the UiBRG register =  $\frac{f_{EXT}}{\text{Bit Rate} \times 16} - 1$

$f_{EXT}$  : Count source frequency of the UiBRG register (external clock)

**Figure 13.11 Calculation Formula of UiBRG (i=0 to 1) Register Setting Value**

**Table 13.7 Bit Rate Setting Example in UART Mode**

Bit Rate (bps)	BRG Count Source	System Clock = 20MHz			System Clock = 8MHz		
		BRG Setting Value	Actual Time(bps)	Error(%)	BRG Setting Value	Actual Time(bps)	Error(%)
1200	f8	129 (81 <sub>16</sub> )	1201.92	0.16	51 (33 <sub>16</sub> )	1201.92	0.16
2400	f8	64 (40 <sub>16</sub> )	2403.85	0.16	25 (19 <sub>16</sub> )	2403.85	0.16
4800	f8	32 (20 <sub>16</sub> )	4734.85	-1.36	12 (0C <sub>16</sub> )	4807.69	0.16
9600	f1	129 (81 <sub>16</sub> )	9615.38	0.16	51 (33 <sub>16</sub> )	9615.38	0.16
14400	f1	86 (56 <sub>16</sub> )	14367.82	-0.22	34 (22 <sub>16</sub> )	14285.71	-0.79
19200	f1	64 (40 <sub>16</sub> )	19230.77	0.16	25 (19 <sub>16</sub> )	19230.77	0.16
28800	f1	42 (2A <sub>16</sub> )	29069.77	0.94	16 (10 <sub>16</sub> )	29411.76	2.12
31250	f1	39 (27 <sub>16</sub> )	31250.00	0.00	15 (0F <sub>16</sub> )	31250.00	0.00
38400	f1	32 (20 <sub>16</sub> )	37878.79	-1.36	12 (0C <sub>16</sub> )	38461.54	0.16
51200	f1	23 (17 <sub>16</sub> )	52083.33	1.73	9 (09 <sub>16</sub> )	50000.00	-2.34

## 14. A/D Converter

The A/D converter consists of one 10-bit successive approximation A/D converter circuit with a capacitive coupling amplifier. The analog inputs share the pins with P00 to P07 and P10 to P13. Therefore, when using these pins, make sure the corresponding port direction bits are set to "0" (input mode).

When not using the A/D converter, set the VCUT bit to "0" (Vref unconnected), so that no current will flow from the VREF pin into the resistor ladder, helping to reduce the power consumption of the chip.

The result of A/D conversion is stored in the AD register.

Table 14.1 shows the performance of the A/D converter. Figure 14.1 shows a block diagram of the A/D converter, and Figures 14.2 and 14.3 show the A/D converter-related registers.

**Table 14.1 Performance of A/D converter**

Item	Performance
Method of A/D conversion	Successive approximation (capacitive coupling amplifier)
Analog input voltage <sup>(1)</sup>	0V to Vref
Operating clock $\phi_{AD}$ <sup>(2)</sup>	AVCC = 5V fAD, divide-by-2 of fAD, divide-by-4 of fAD AVCC = 3V divide-by-2 of fAD, divide-by-4 of fAD
Resolution	8-bit or 10-bit (selectable)
Integral nonlinearity error	AVCC = Vref = 5V <ul style="list-style-type: none"> <li>• 8-bit resolution <math>\pm 2</math> LSB</li> <li>• 10-bit resolution <math>\pm 3</math> LSB</li> </ul> AVCC = Vref = 3.3 V <ul style="list-style-type: none"> <li>• 8-bit resolution <math>\pm 2</math> LSB</li> <li>• 10-bit resolution <math>\pm 5</math> LSB</li> </ul>
Operating modes	One-shot mode and repeat mode <sup>(3)</sup>
Analog input pins	12 pins (AN0 to AN11)
A/D conversion start condition	ADST bit in ADCON0 register is set to "1" (A/D conversion starts)
Conversion speed per pin	<ul style="list-style-type: none"> <li>• Without sample and hold function 8-bit resolution: 49 <math>\phi_{AD}</math> cycles, 10-bit resolution: 59 <math>\phi_{AD}</math> cycles</li> <li>• With sample and hold function 8-bit resolution: 28 <math>\phi_{AD}</math> cycles, 10-bit resolution: 33 <math>\phi_{AD}</math> cycles</li> </ul>

**NOTES:**

1. Does not depend on use of sample and hold function.
2. The frequency of  $\phi_{AD}$  must be 10 MHz or less.  
When AVCC is less than 4.2V,  $\phi_{AD}$  must be fAD/2 or less by dividing fAD.  
Without sample and hold function, the  $\phi_{AD}$  frequency should be 250 kHz or more.  
With the sample and hold function, the  $\phi_{AD}$  frequency should be 1 MHz or more.
3. In repeat mode, only 8-bit mode can be used.

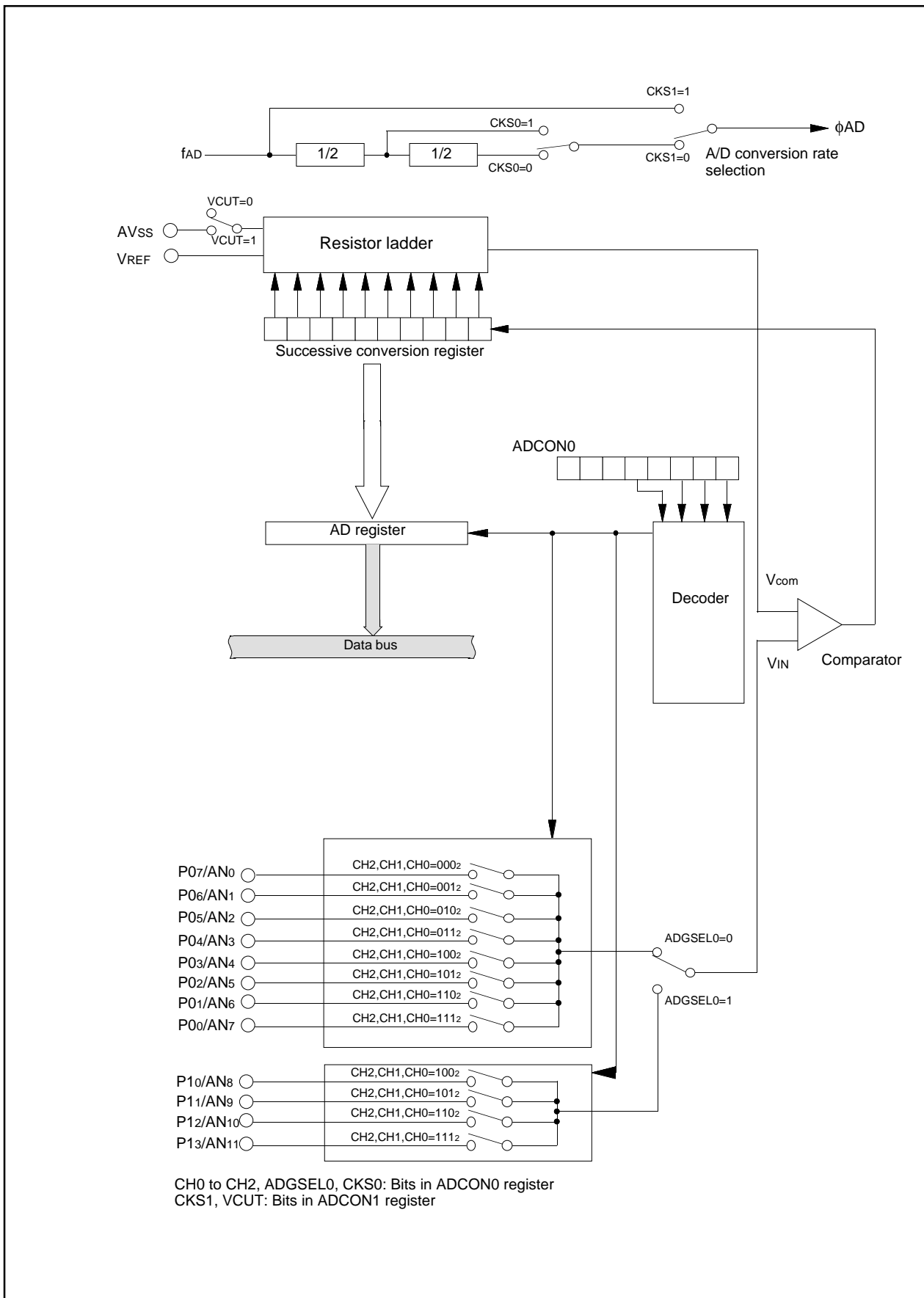

Figure 14.1 A/D Converter Block Diagram



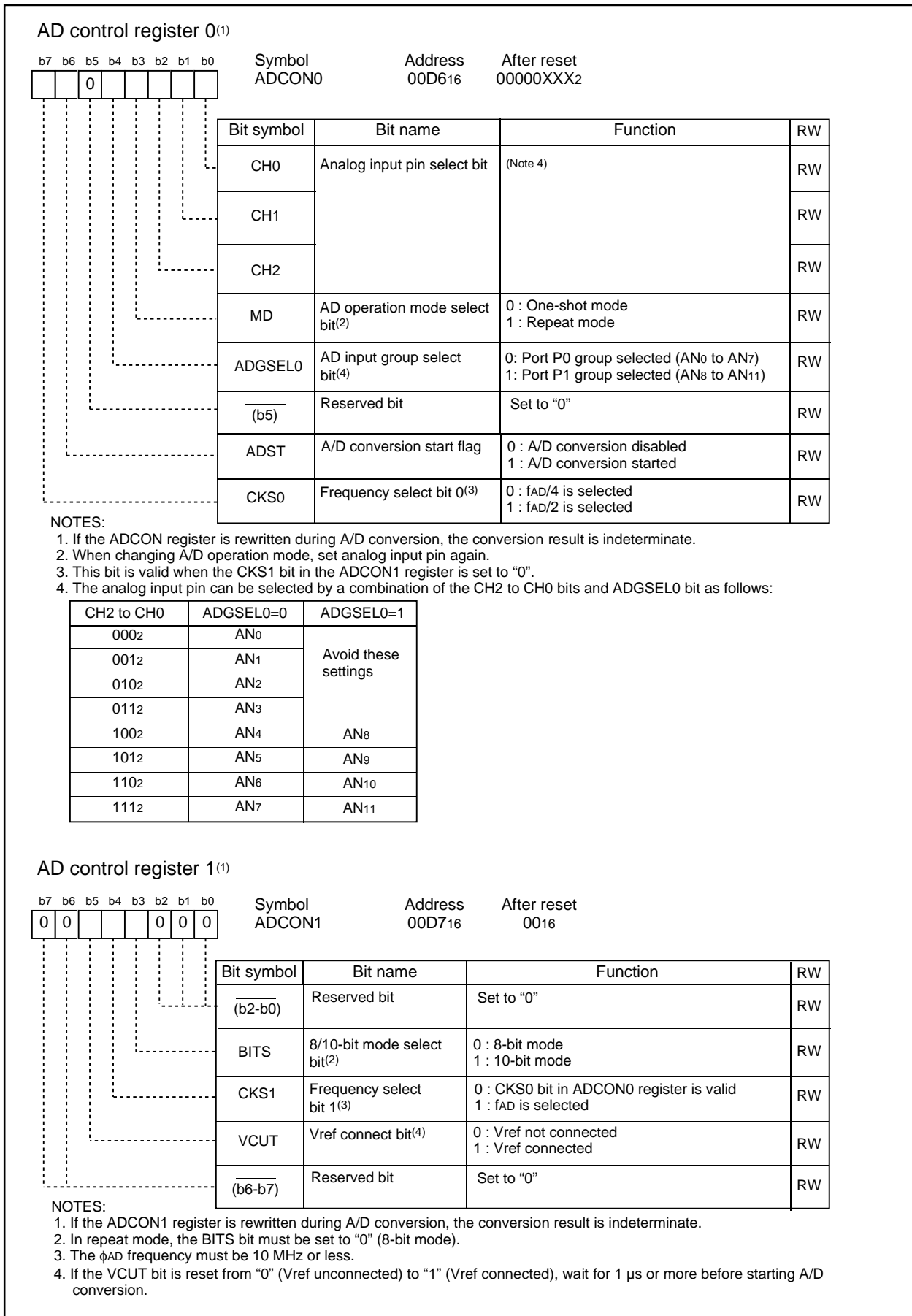

Figure 14.2 ADCON0 Register and ADCON1 Register

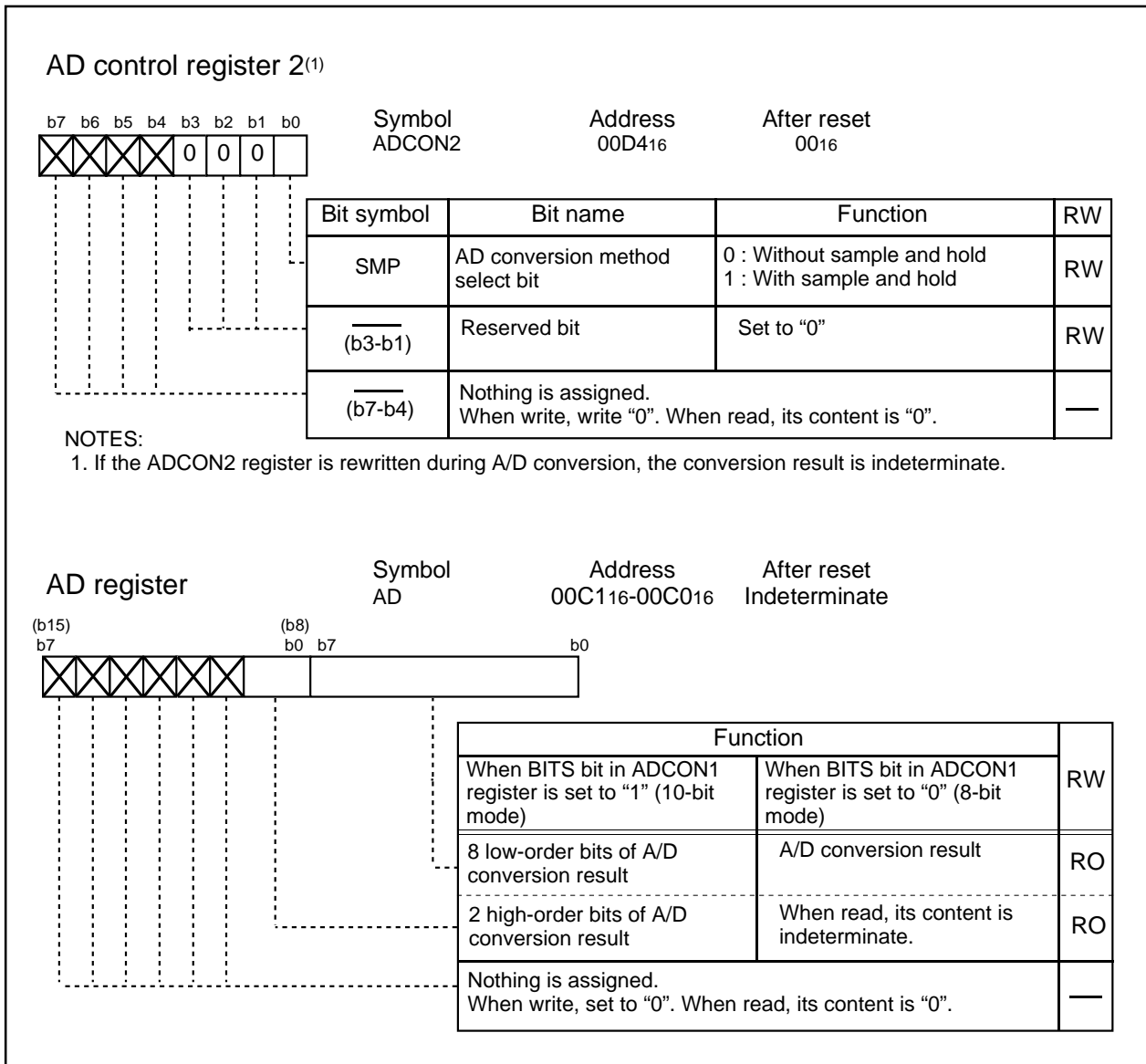

Figure 14.3 ADCON2 Register and AD Register

### 14.1 One-shot Mode

In one-shot mode, the input voltage on one selected pin is A/D converted once. Table 14.2 lists the specifications of one-shot mode. Figure 14.4 shows the ADCON0 and ADCON1 registers in one-shot mode.

**Table 14.2 One-shot Mode Specifications**

Item	Specification
Function	Input voltage on one pin selected by CH2 to CH0 and ADGSEL0 bit is A/D converted once.
Start condition	Set ADST bit to "1"
Stop condition	<ul style="list-style-type: none"> <li>• Completion of A/D conversion (ADST bit is set to "0")</li> <li>• Set ADST bit to "0"</li> </ul>
Interrupt request generation timing	End of A/D conversion
Input pin	One of AN0 to AN11, as selected
Reading of result of A/D converter	Read AD register

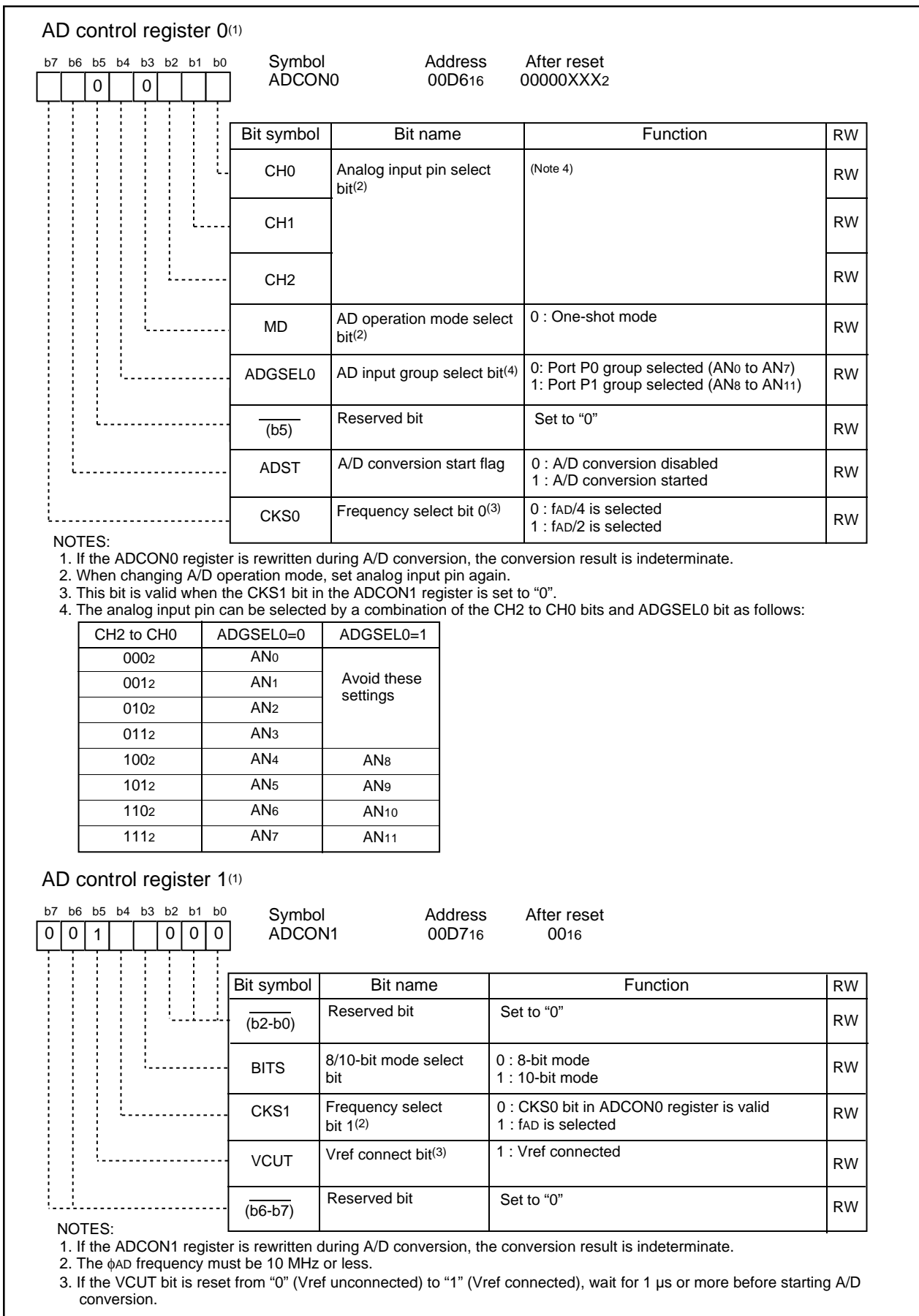

Figure 14.4 ADCON0 Register and ADCON1 Registers in One-shot Mode

### 14.2 Repeat Mode

In repeat mode, the input voltage on one selected pin is A/D converted repeatedly. Table 14.3 lists the specifications of repeat mode. Figure 14.5 shows the ADCON0 and ADCON1 registers in repeat mode.

**Table 14.3 Repeat Mode Specifications**

Item	Specification
Function	Input voltage on one pin selected by CH2 to CH0 and ADGSEL0 bits is A/D converted repeatedly
Start condition	Set ADST bit to "1"
Stop condition	Set ADST bit to "0"
Interrupt request generation timing	None generated
Input pin	One of AN0 to AN11, as selected
Reading of result of A/D converter	Read AD register

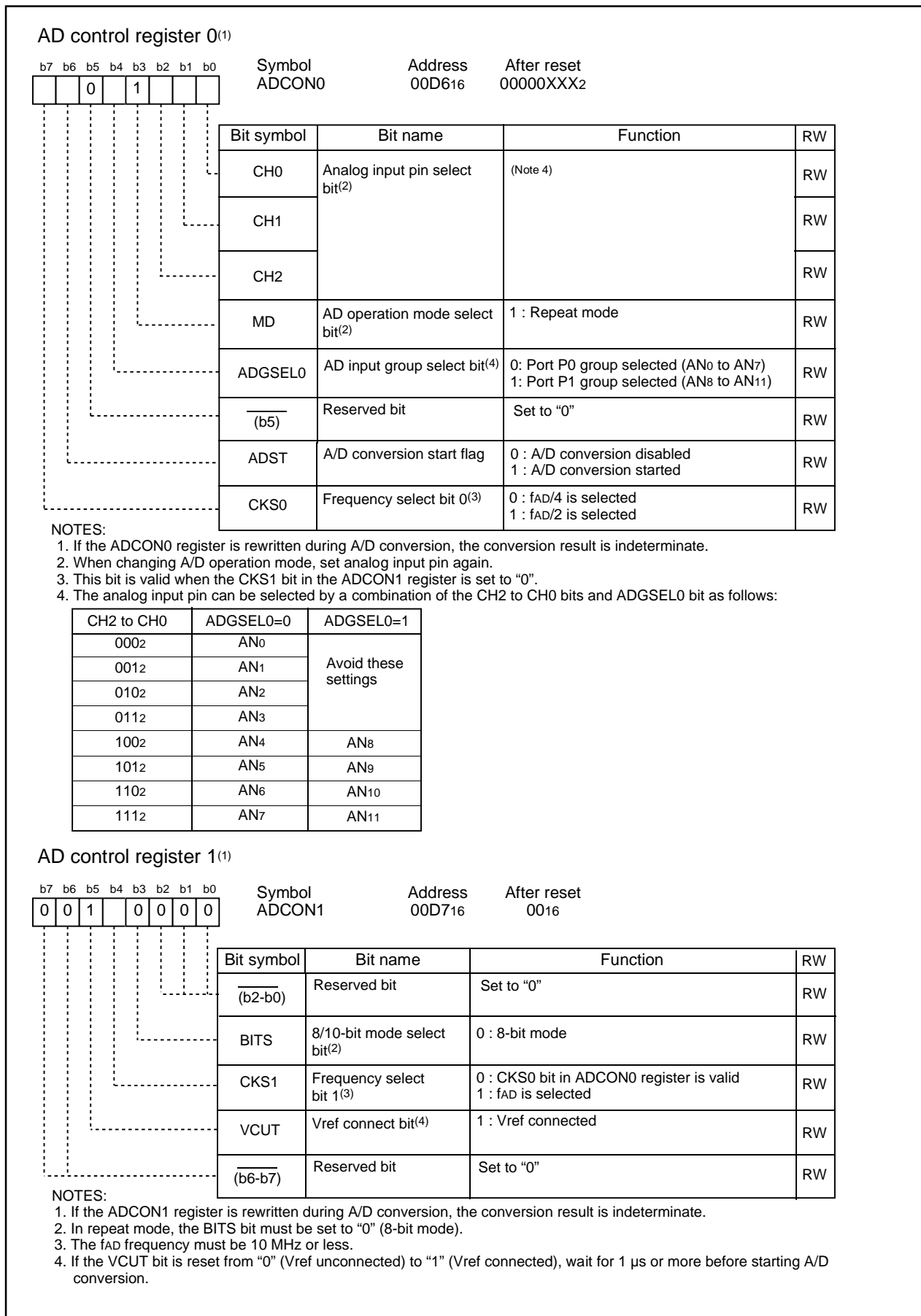
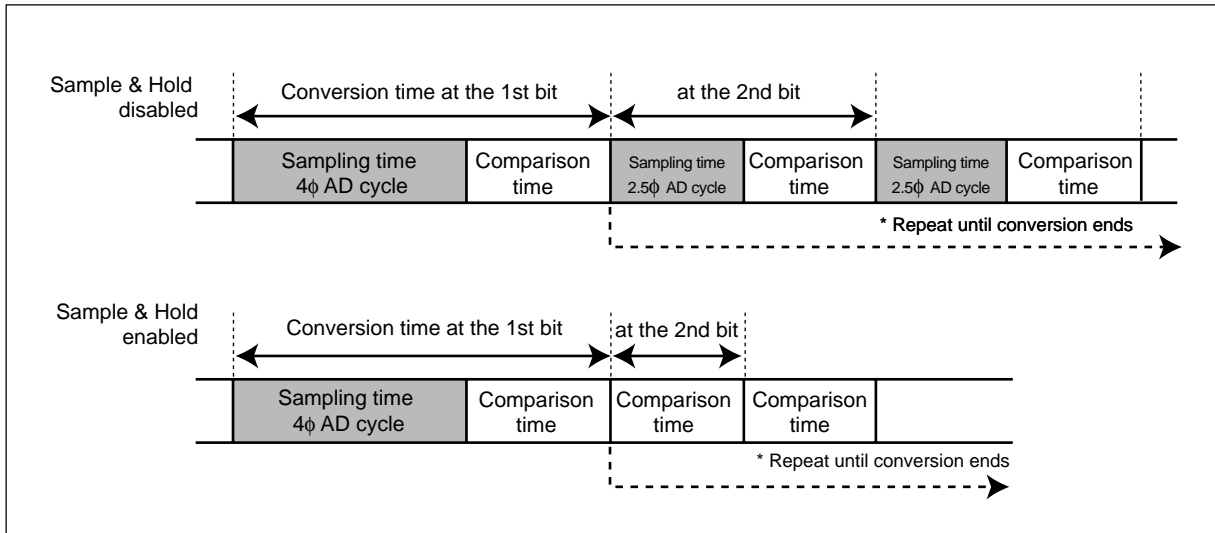

Figure 14.5 ADCON0 Register and ADCON1 Register in Repeat Mode

**14.3 Sample and Hold**

If the SMP bit in the ADCON2 register is set to “1” (with sample-and-hold), the conversion speed per pin is increased to 28  $\phi$ AD cycles for 8-bit resolution or 33  $\phi$ AD cycles for 10-bit resolution. Sample-and-hold is effective in all operation modes. Select whether or not to use the sample-and-hold function before starting A/D conversion.

When performing the A/D conversion, charge the comparator capacitor inside the microcomputer. Figure 14.6 shows the A/D conversion timing diagram.



**Figure 14.6 A/D Conversion Timing Diagram**

**14.4 A/D conversion cycles**

Figure 14.7 shows the A/D conversion cycles.

A/D conversion mode		Conversion time	Sampling time	Comparison time	Sampling time	Comparison time	End process
Without sample & hold	8 bits	49 $\phi$ AD	4 $\phi$ AD	2.0 $\phi$ AD	2.5 $\phi$ AD	2.5 $\phi$ AD	8.0 $\phi$ AD
Without sample & hold	10 bits	59 $\phi$ AD	4 $\phi$ AD	2.0 $\phi$ AD	2.5 $\phi$ AD	2.5 $\phi$ AD	8.0 $\phi$ AD
With sample & hold	8 bits	28 $\phi$ AD	4 $\phi$ AD	2.5 $\phi$ AD	0.0 $\phi$ AD	2.5 $\phi$ AD	4.0 $\phi$ AD
With sample & hold	10 bits	33 $\phi$ AD	4 $\phi$ AD	2.5 $\phi$ AD	0.0 $\phi$ AD	2.5 $\phi$ AD	4.0 $\phi$ AD

**Figure 14.7 A/D Conversion Cycles**

14.5 Internal Equivalent Circuit of Analog Input

Figure 14.8 shows the internal equivalent circuit of analog input.

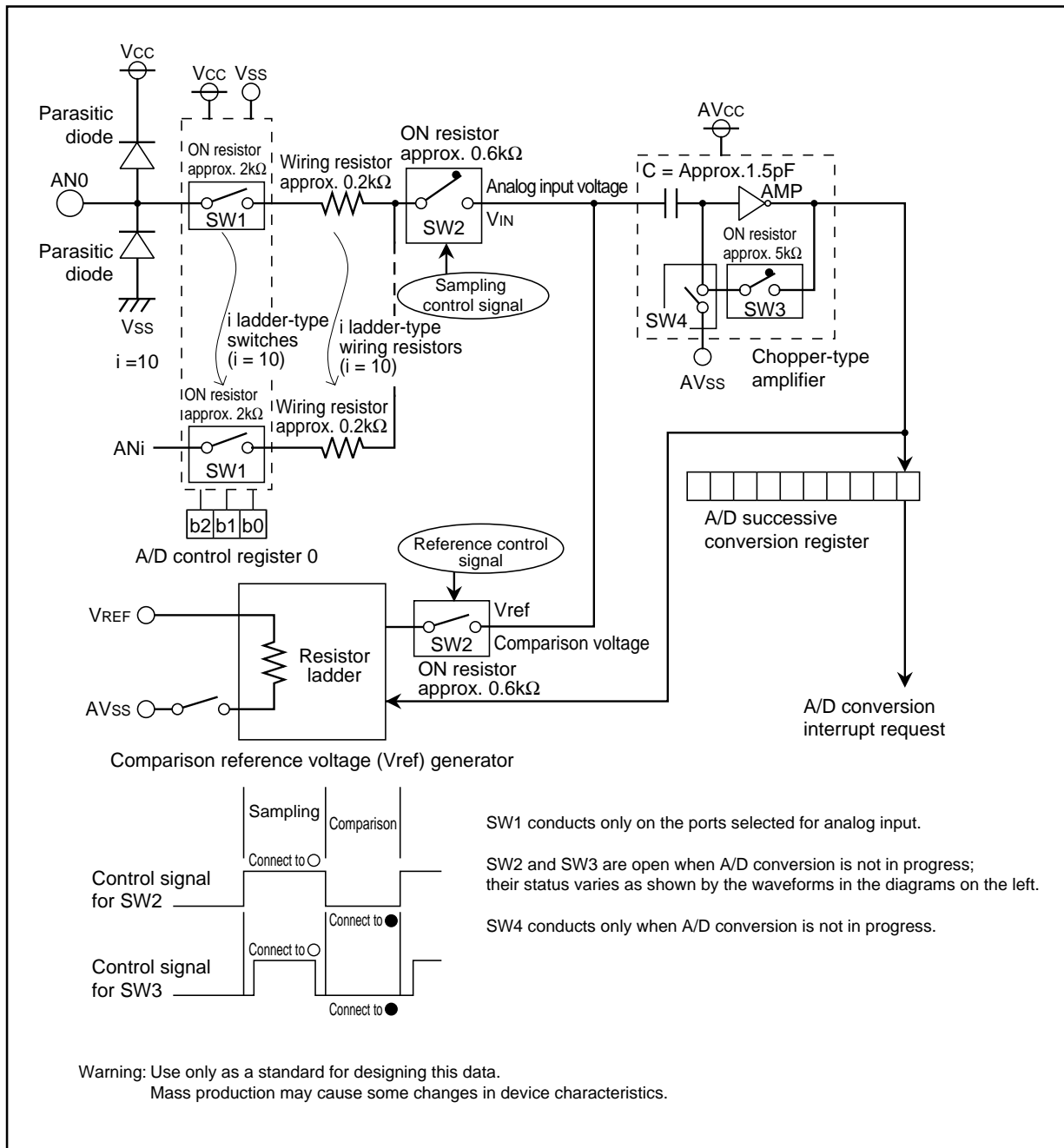

Figure 14.8 Internal Equivalent Circuit to Analog Input



### 14.6 Inflow Current Bypass Circuit

Figure 14.9 shows the configuration of the inflow current bypass circuit, figure 14.10 shows the example of an inflow current bypass circuit where VCC or more is applied.

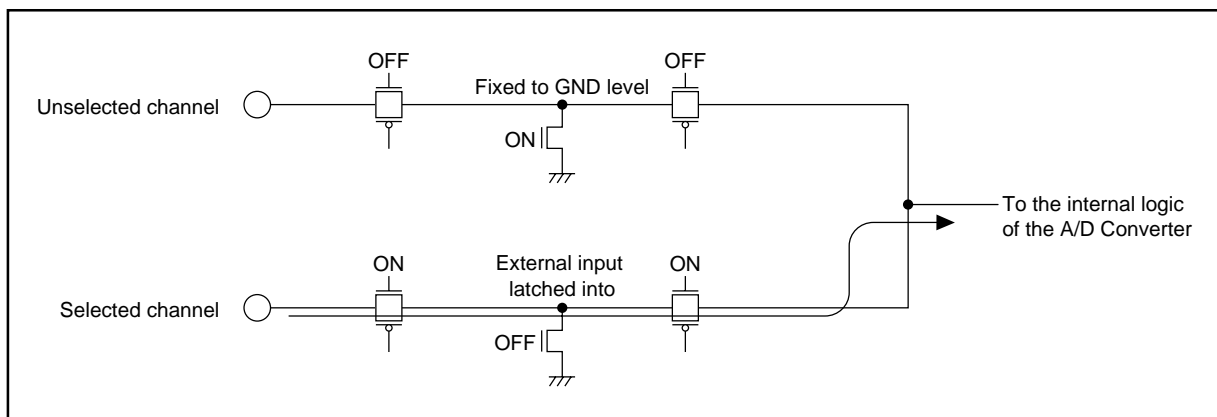

Figure 14.9 Configuration of the Inflow Current Bypass Circuit

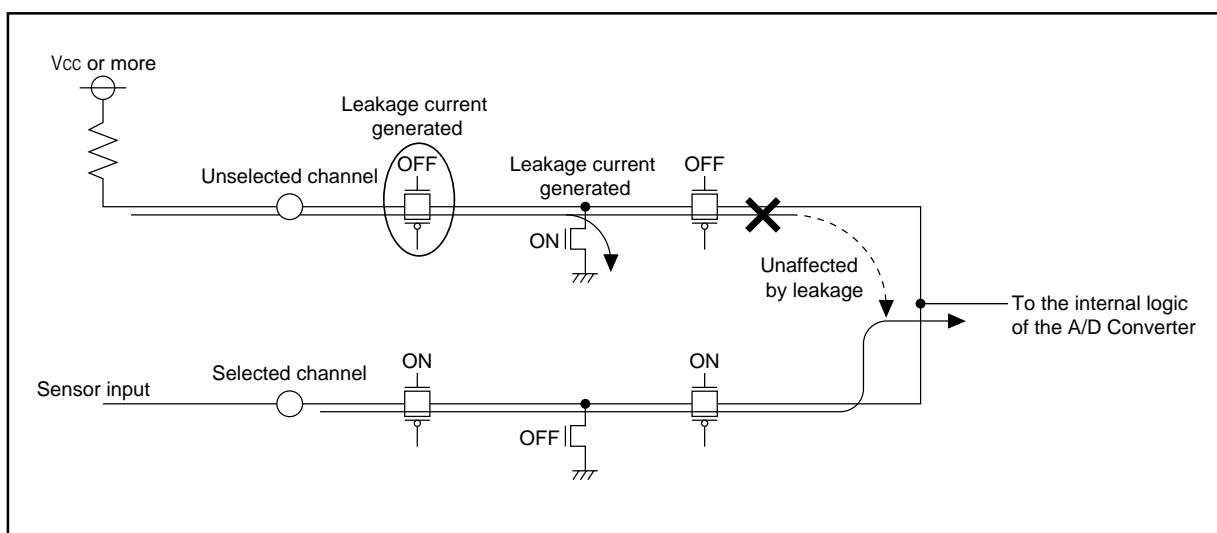

Figure 14.10 Example of an Inflow Current Bypass Circuit where VCC or More is Applied

### 14.7 Output Impedance of Sensor under A/D Conversion

To carry out A/D conversion properly, charging the internal capacitor C shown in Figure 14.11 has to be completed within a specified period of time. T (sampling time) as the specified time. Let output impedance of sensor equivalent circuit be R0, microcomputer's internal resistance be R, precision (error) of the A/D converter be X, and the A/D converter's resolution be Y (Y is 1024 in the 10-bit mode, and 256 in the 8-bit mode).

$$VC \text{ is generally } VC = VIN \left\{ 1 - e^{-\frac{1}{C(R0+R)}t} \right\}$$

$$\text{And when } t = T, \quad VC = VIN - \frac{X}{Y} VIN = VIN \left( 1 - \frac{X}{Y} \right)$$

$$e^{-\frac{1}{C(R0+R)}T} = \frac{X}{Y}$$

$$-\frac{1}{C(R0+R)}T = \ln \frac{X}{Y}$$

$$\text{Hence, } R0 = -\frac{T}{C \cdot \ln \frac{X}{Y}} - R$$

Figure 14.11 shows analog input pin and external sensor equivalent circuit. When the difference between VIN and VC becomes 0.1 LSB, we find impedance R0 when voltage between pins VC changes from 0 to VIN - (0.1/1024) VIN in time T. (0.1/1024) means that A/D precision drop due to insufficient capacitor charge is held to 0.1 LSB at time of A/D conversion in the 10-bit mode. Actual error however is the value of absolute precision added to 0.1 LSB. When f(XIN) = 10 MHz, T = 0.25 μs in the A/D conversion mode with sample & hold. Output impedance R0 for sufficiently charging capacitor C within time T is determined as follows.

T = 0.25 μs, R = 2.8 kΩ, C = 1.5 pF, X = 0.1, and Y = 1024. Hence,

$$R0 = -\frac{0.25 \times 10^{-6}}{6.0 \times 10^{-12} \cdot \ln \frac{0.1}{1024}} - 2.8 \times 10^3 \approx 7.3 \times 10^3$$

Thus, the allowable output impedance of the sensor circuit capable of thoroughly driving the A/D converter turns out to be approximately 7.3 kΩ.

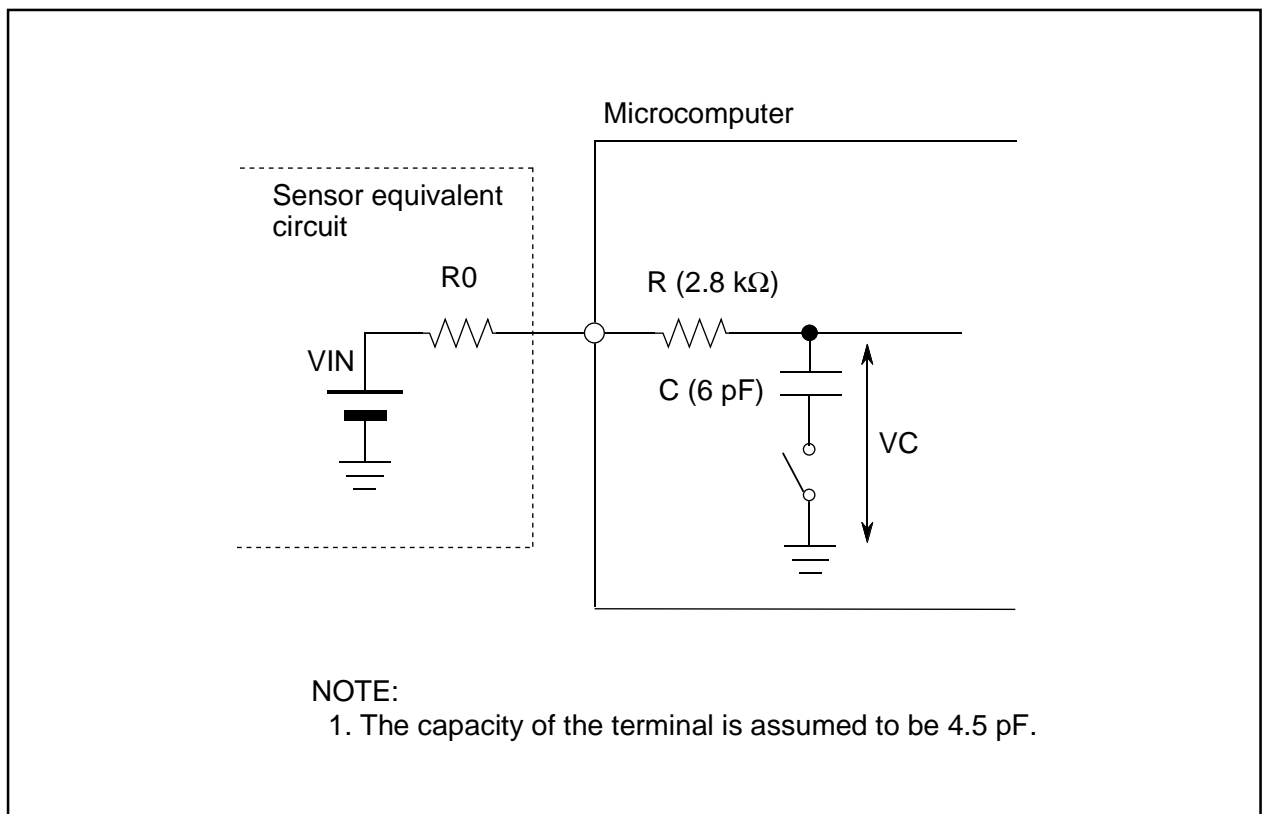

Figure 14.11 Analog Input Pin and External Sensor Equivalent Circuit

# 15. Programmable I/O Ports

## 15.1 Description

The programmable input/output ports (hereafter referred to as "I/O ports") consist of 22 lines P0, P1, P30 to P33, P37, and P45. Each port can be set for input or output every line by using a direction register, and can also be chosen to be or not be pulled high every 4 lines. The port P1 allows the drive capacity of its N-channel output transistor to be set as necessary. The port P1 can be used as LED drive port if the drive capacity is set to "HIGH".

P46 and P47 can be used as an input only port if the main clock oscillation circuit is not used.

Figures 15.1 to 15.5 show the I/O ports. Figure 15.6 shows the I/O pins.

Each pin functions as an I/O port or a peripheral function input/output.

For details on how to set peripheral functions, refer to each functional description in this manual. If any pin is used as a peripheral function input, set the direction bit for that pin to "0" (input mode). Any pin used as an output pin for peripheral functions is directed for output no matter how the corresponding direction bit is set.

### 15.1.1 Port Pi Direction Register (PDi Register, i = 0, 1, 3, 4)

Figure 15.7 shows the PDi register.

This register selects whether the I/O port is to be used for input or output. The bits in this register correspond one for one to each port.

### 15.1.2 Port Pi Register (Pi Register, i = 0 to 4)

Figure 15.8 shows the Pi register.

Data I/O to and from external devices are accomplished by reading and writing to the Pi register. The Pi register consists of a port latch to hold the output data and a circuit to read the pin status. For ports set for input mode, the input level of the pin can be read by reading the corresponding Pi register, and data can be written to the port latch by writing to the Pi register.

For ports set for output mode, the port latch can be read by reading the corresponding Pi register, and data can be written to the port latch by writing to the Pi register. The data written to the port latch is output from the pin. The bits in the Pi register correspond one for one to each port.

### 15.1.3 Pull-up Control Register 0, Pull-up Control Register 1 (PUR0 and PUR1 Registers)

Figure 15.9 shows the PUR0 and PUR1 registers.

The PUR0 and PUR1 register bits can be used to select whether or not to pull the corresponding port high in 4 bit units. The port chosen to be pulled high has a pull-up resistor connected to it when the direction bit is set for input mode.

### 15.1.4 Port P1 Drive Capacity Control Register (DRR Register)

Figure 15.9 shows the DRR register.

The DRR register is used to control the drive capacity of the port P1 N-channel output transistor. The bits in this register correspond one for one to each port.

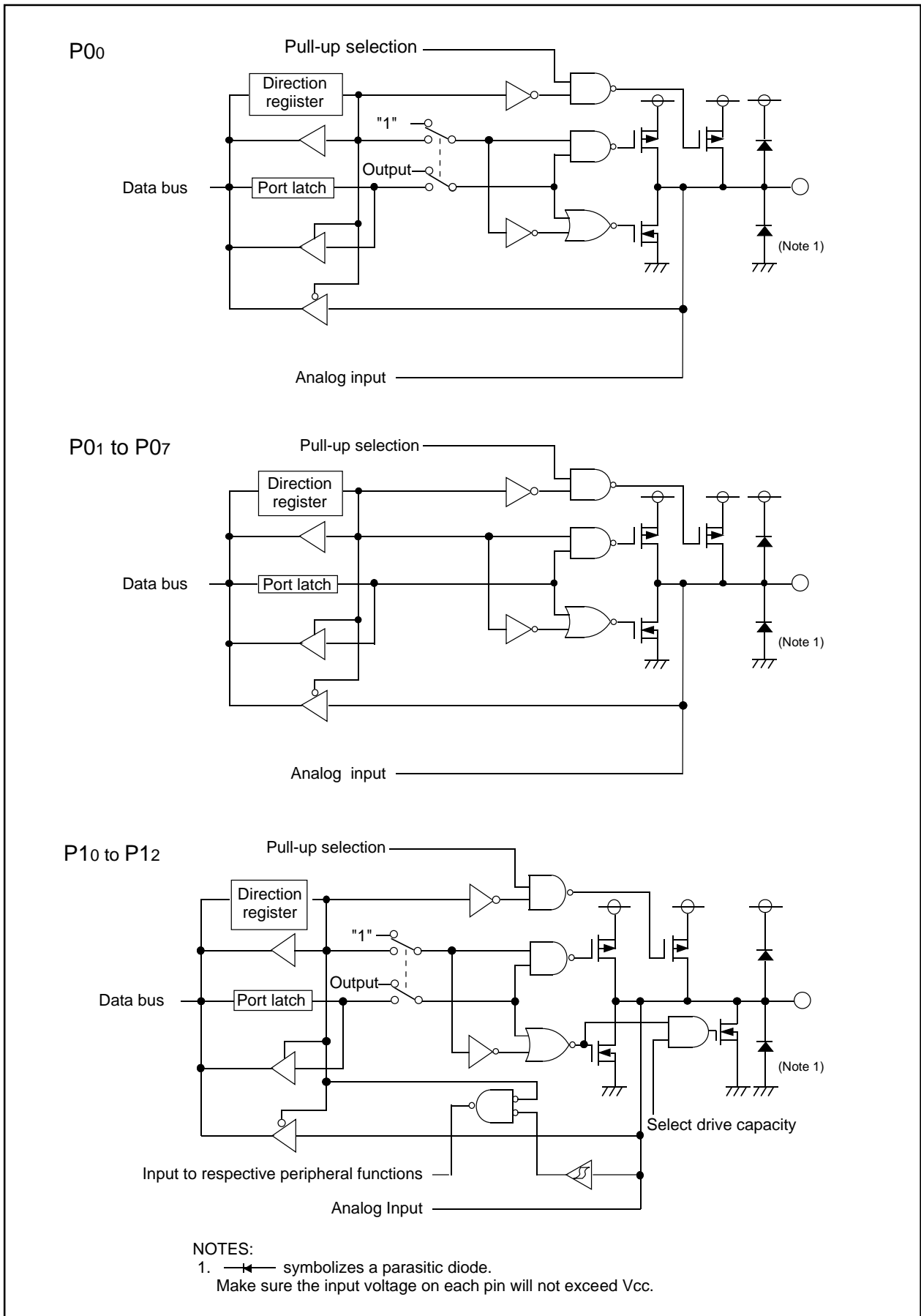

Figure 15.1 Programmable I/O Ports (1)

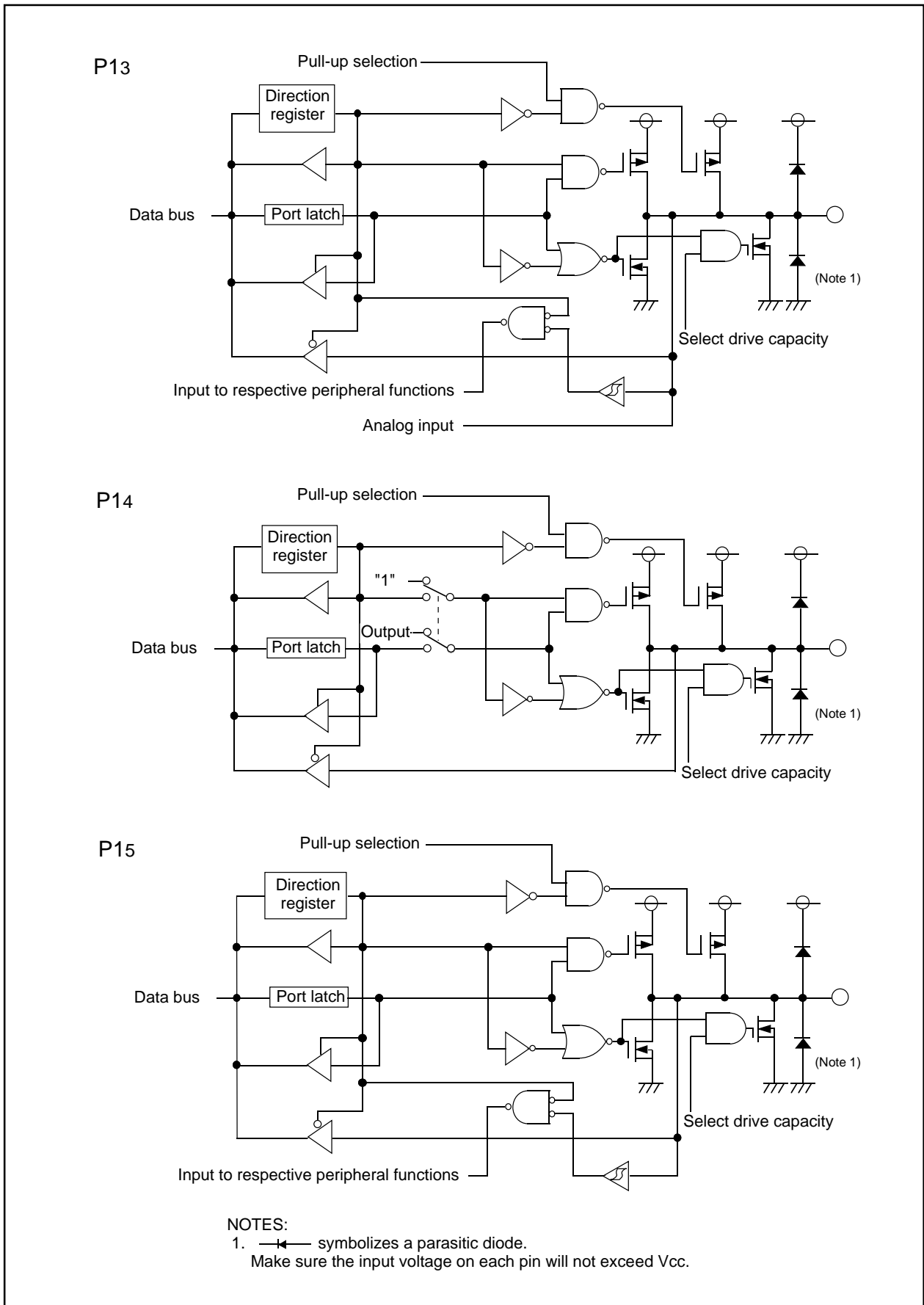

Figure 15.2 Programmable I/O Ports (2)

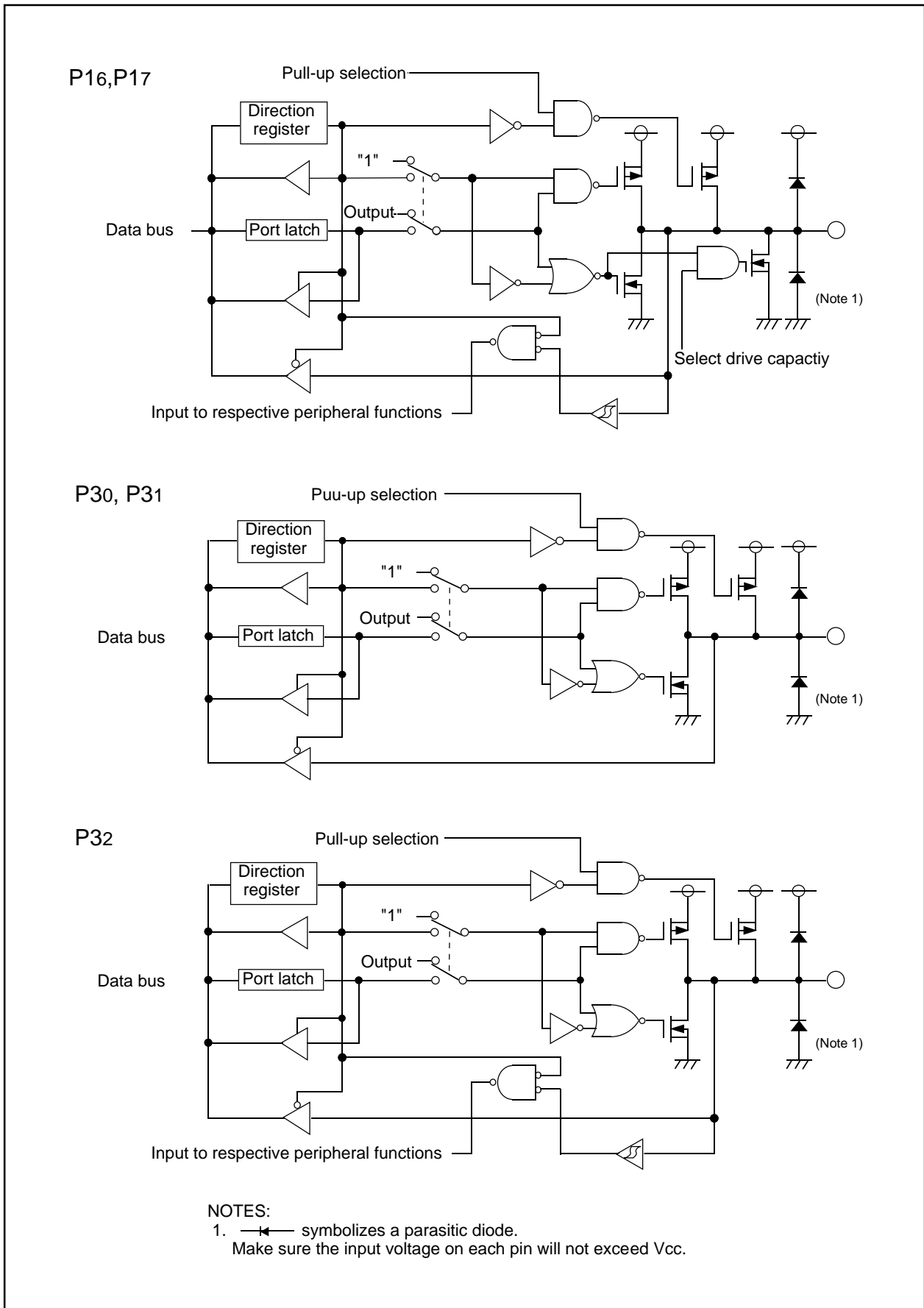

Figure 15.3 Programmable I/O Ports (3)

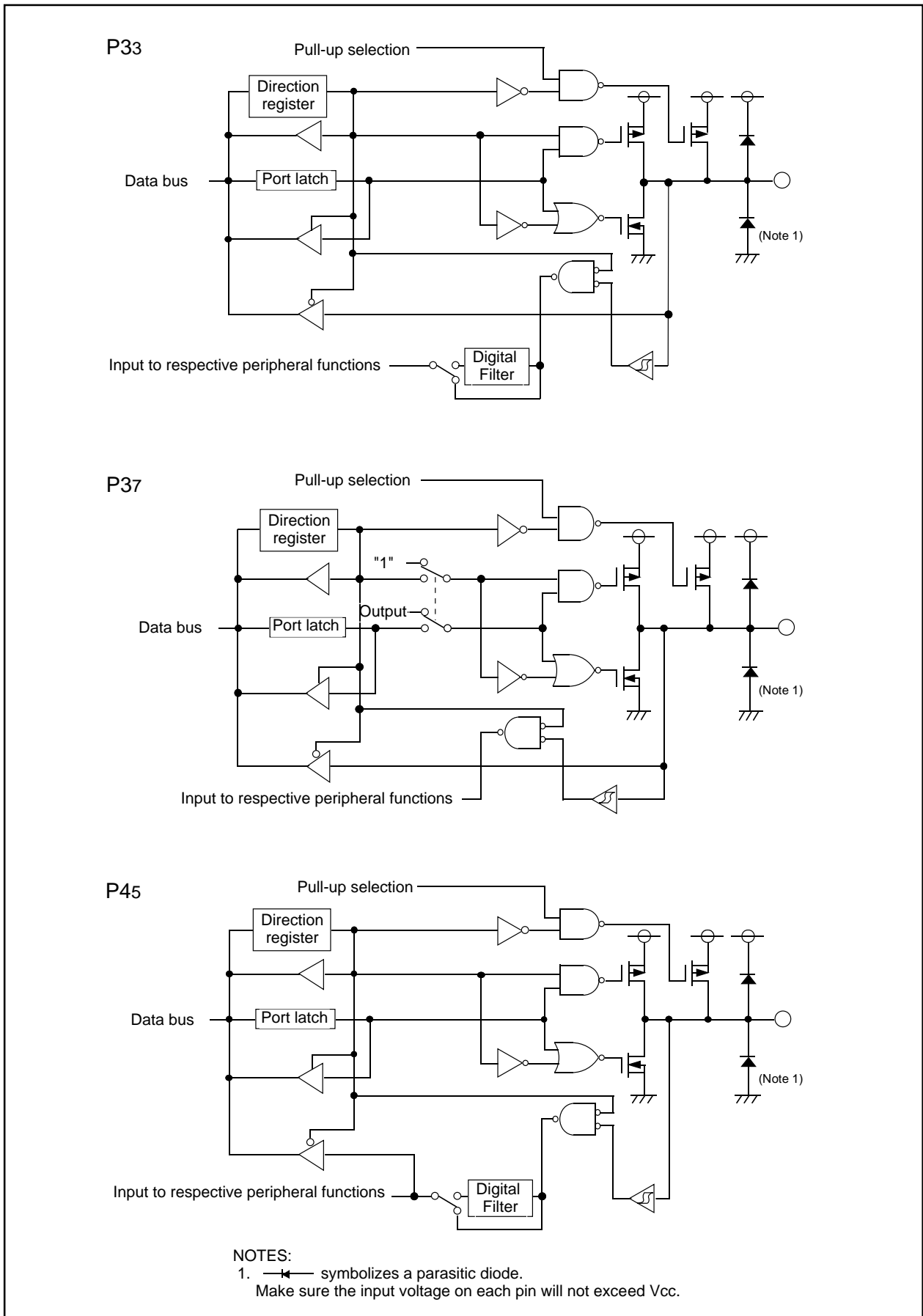

Figure 15.4 Programmable I/O Ports (4)



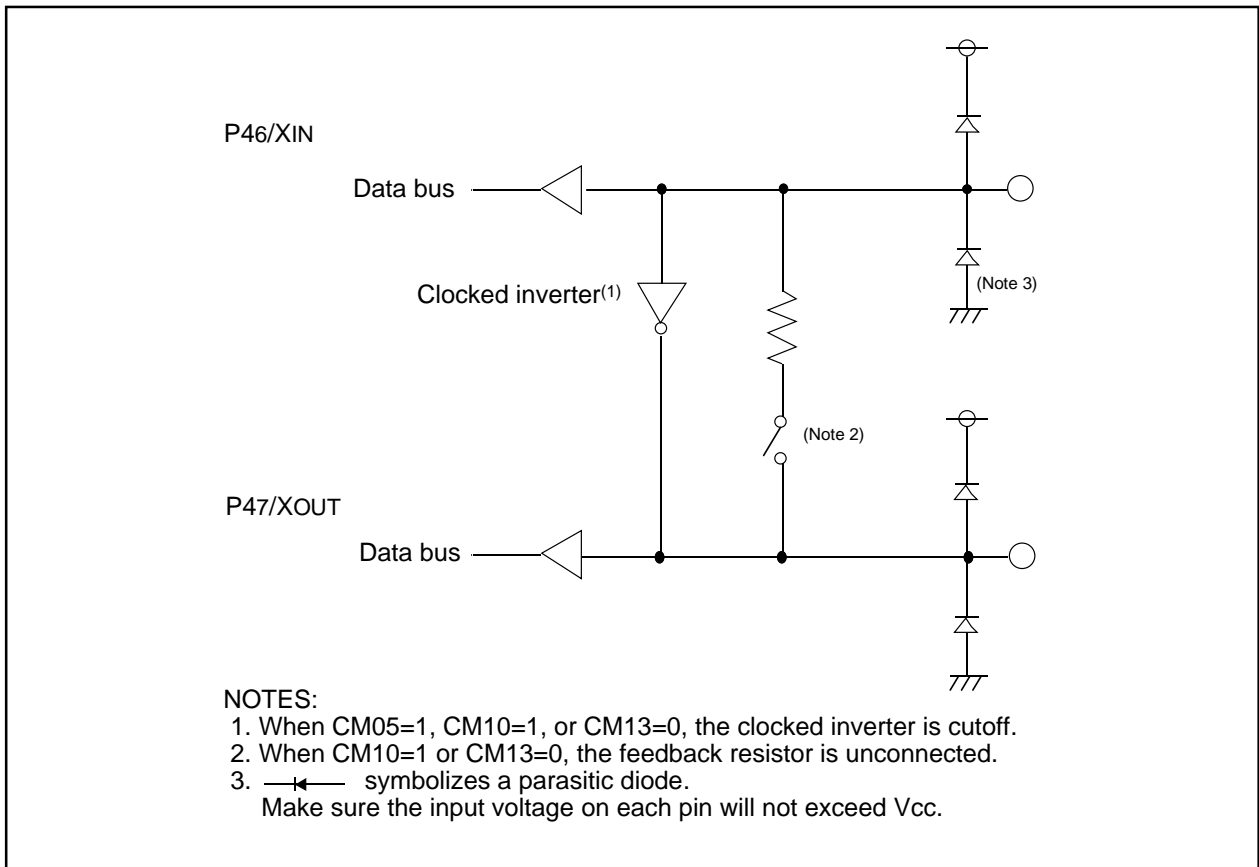

Figure 15.5 Programmable I/O Port (5)

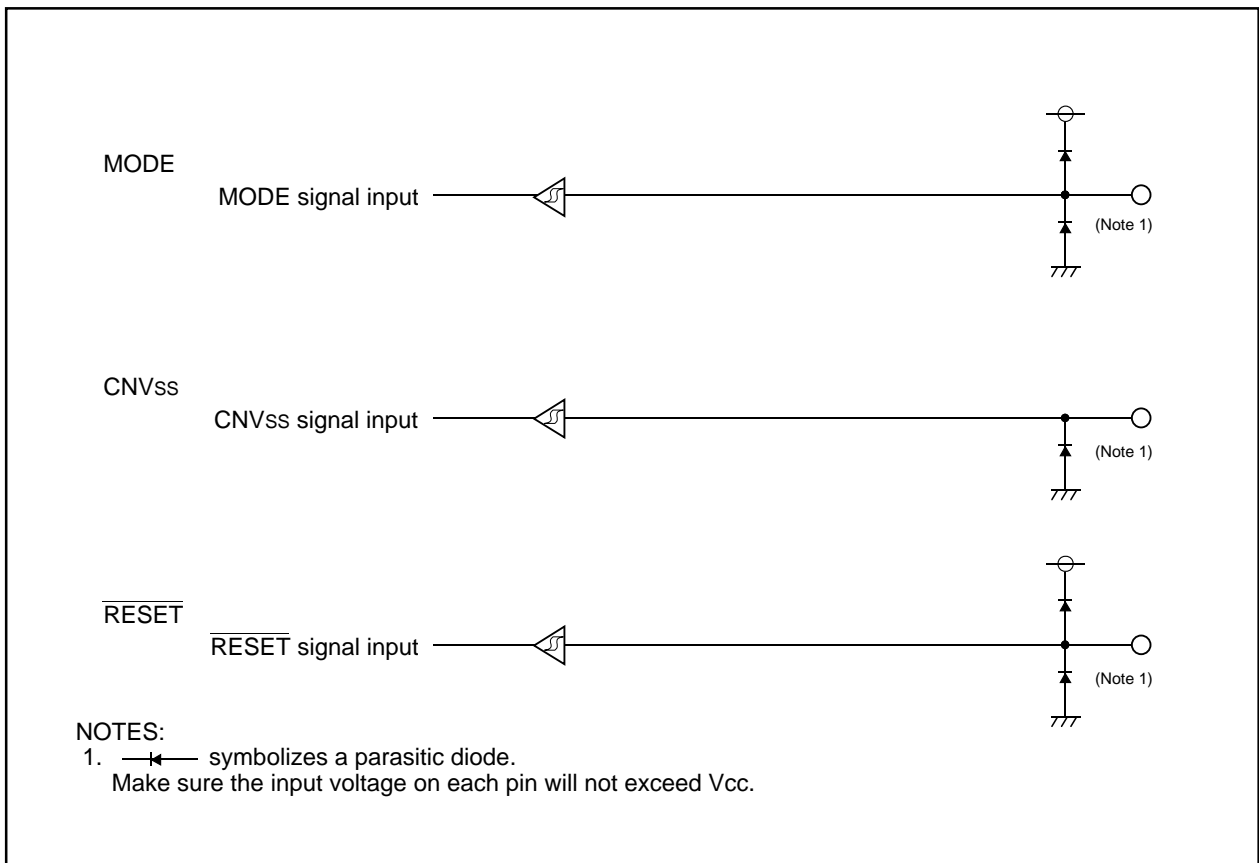

Figure 15.6 I/O Pins

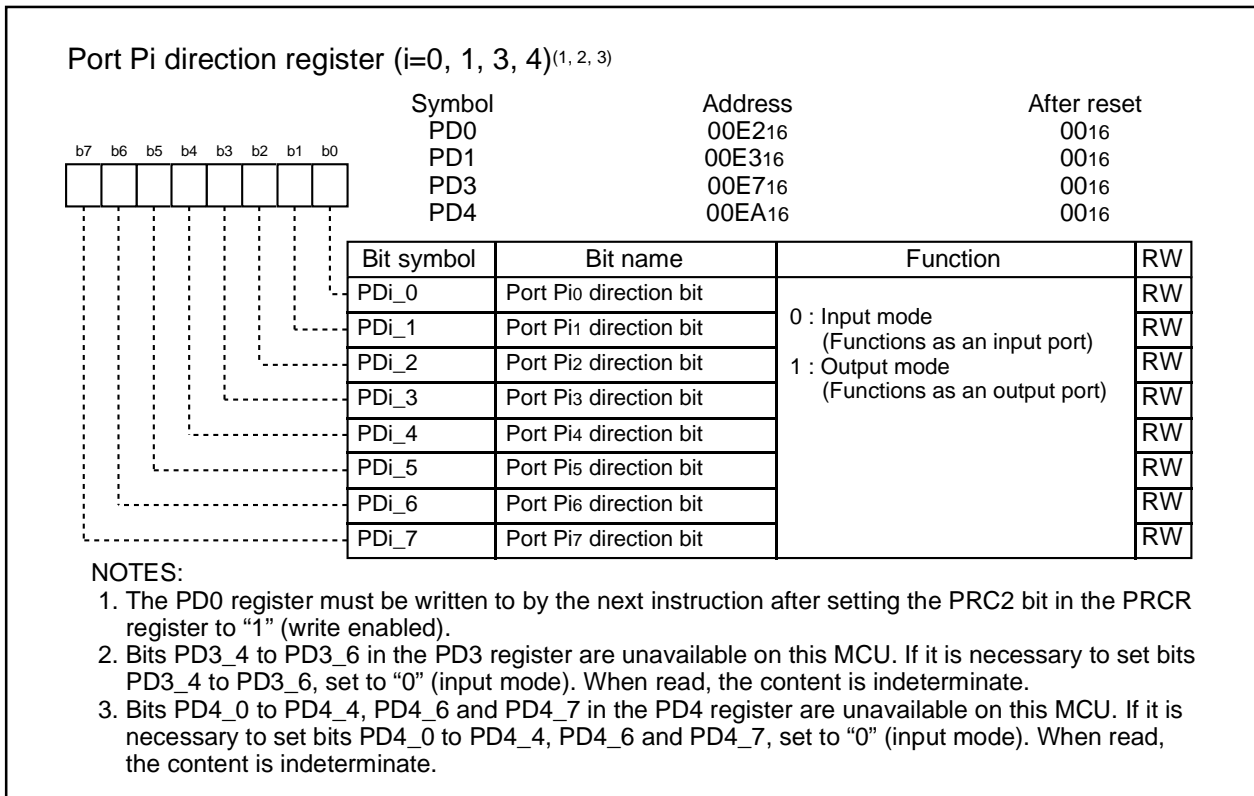

Figure 15.7 PD0 Register, PD1 Register, PD3 Register, and PD4 Register

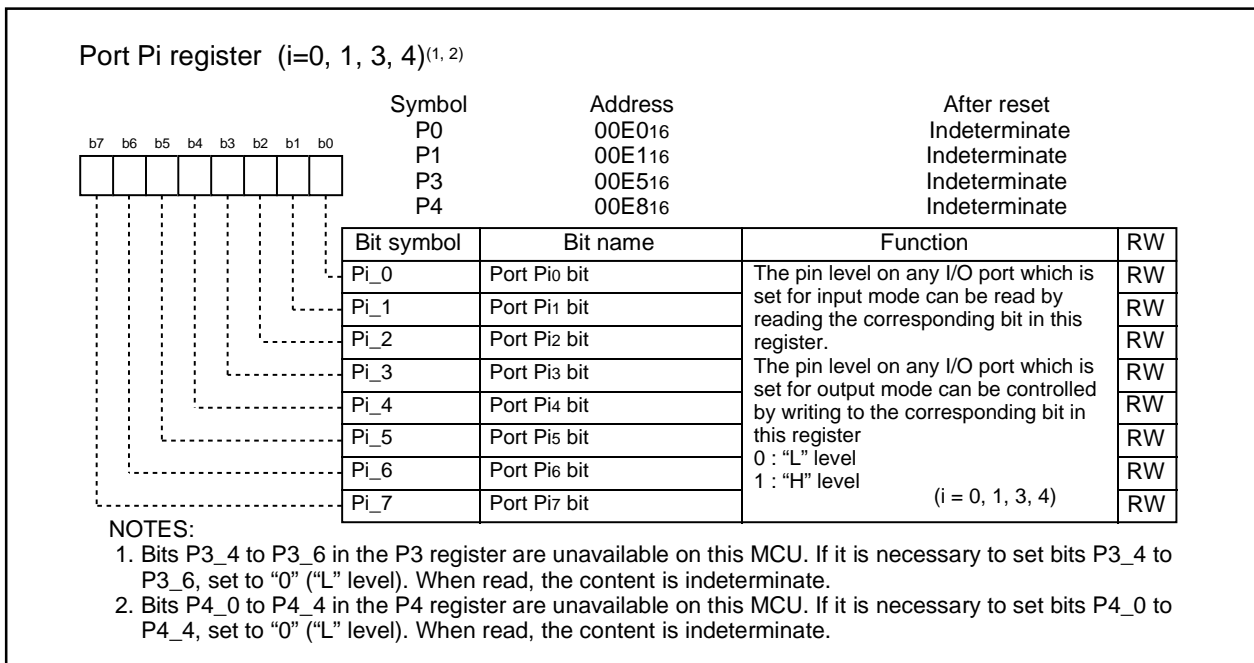
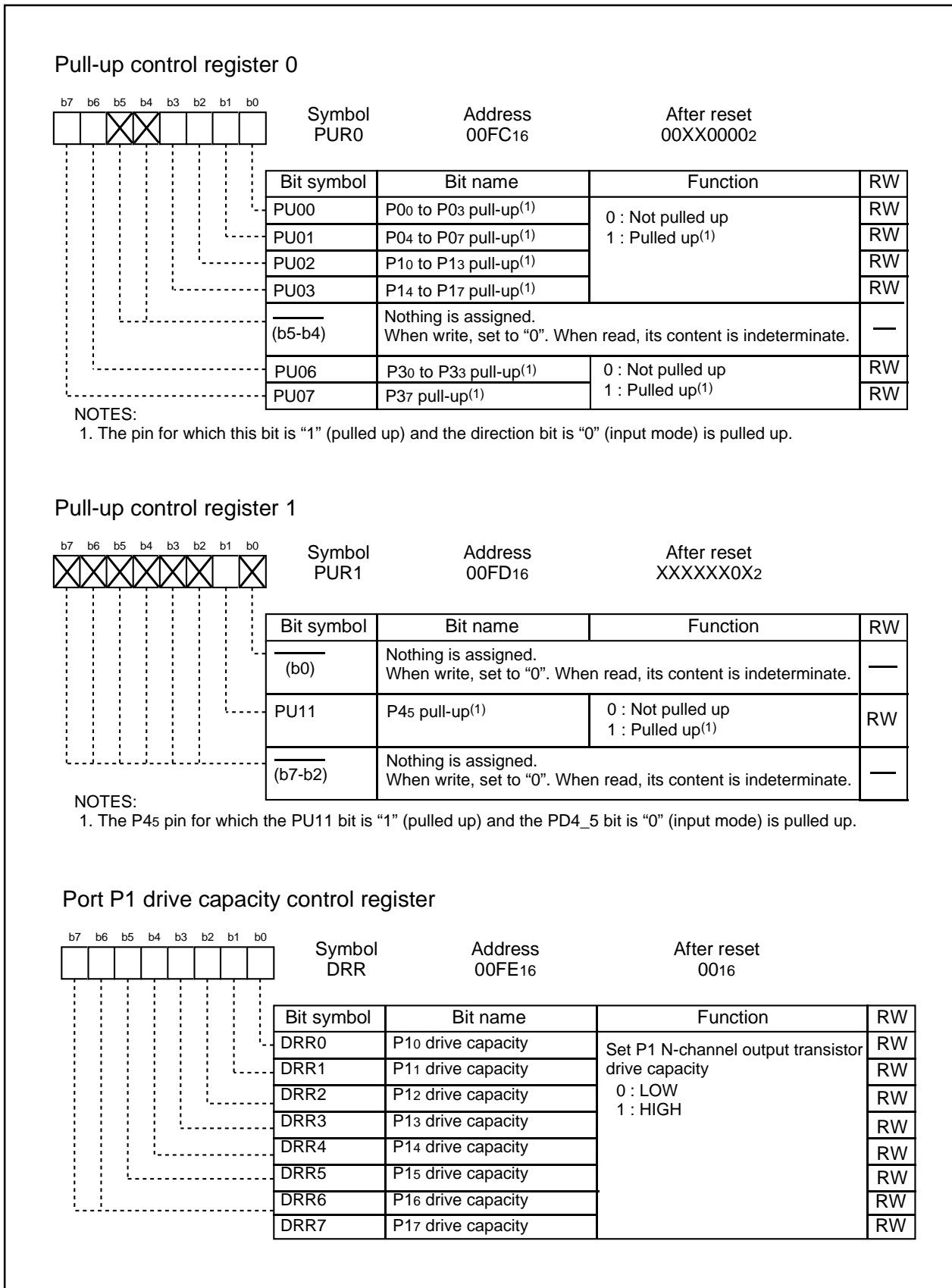

Figure 15.8 P0 Register to P4 Register



## 15.2 Port setting

Table 15.1 to Table 15.23 list the port setting.

**Table 15.1 Port P00/AN7/TxD11 Setting**

Register	PD0	PUR0	ADCON0	UCON	U1MR	U1C0	Function
Bit	PD0_0	PU00	CH2, CH1, CH0, ADGSEL0	TXD1SEL	SMD2, SMD0	NCH	
Setting value	0	0	XXXX	X	002	X	Input port (not pulled up)
				0	XX		
	0	1	XXXX	X	002	X	Input port (pulled up)
				0	XX		
	0	0	11102	X	002	X	A/D input (AN7)
				0	XX		
1	X	XXXX	X	002	X	Output port	
			0	XX			
X	X	XXXX	1	1X	0	TxD11	
				X1			
X	0	XXXX	1	1X	1	TxD11, N-channel open output	
				X1			

X: "0" or "1"

**Table 15.2 Port P01/AN6 Setting**

Register	PD0	PUR0	ADCON0	Function
Bit	PD0_1	PU00	CH2, CH1, CH0, ADGSEL0	
Setting value	0	0	XXXX	Input port (not pulled up)
	0	1	XXXX	Input port (pulled up)
	0	0	11002	A/D input (AN6)
	1	X	XXXX	Output port

X: "0" or "1"

**Table 15.3 Port P02/AN5 Setting**

Register	PD0	PUR0	ADCON0	Function
Bit	PD0_2	PU00	CH2, CH1, CH0, ADGSEL0	
Setting value	0	0	XXXX	Input port (not pulled up)
	0	1	XXXX	Input port (pulled up)
	0	0	10102	A/D input (AN5)
	1	X	XXXX	Output port

X: "0" or "1"

**Table 15.4 Port P03/AN4 Setting**

Register	PD0	PUR0	ADCON0	Function
Bit	PD0_3	PU00	CH2, CH1, CH0, ADGSEL0	
Setting value	0	0	XXXX	Input port (not pulled up)
	0	1	XXXX	Input port (pulled up)
	0	0	10002	A/D input (AN4)
	1	X	XXXX	Output port

X: "0" or "1"

**Table 15.5 Port P04/AN3 Setting**

Register	PD0	PUR0	ADCON0	Function
Bit	PD0_4	PU01	CH2, CH1, CH0, ADGSEL0	
Setting value	0	0	XXXX	Input port (not pulled up)
	0	1	XXXX	Input port (pulled up)
	0	0	01102	A/D input (AN3)
	1	X	XXXX	Output port

X: "0" or "1"

**Table 15.6 Port P05/AN2 setting**

Register	PD0	PUR0	ADCON0	Function
Bit	PD0_5	PU01	CH2, CH1, CH0, ADGSEL0	
Setting value	0	0	XXXX	Input port (not pulled up)
	0	1	XXXX	Input port (pulled up)
	0	0	01002	A/D input (AN2)
	1	X	XXXX	Output port

X: "0" or "1"

**Table 15.7 Port P06/AN1 Setting**

Register	PD0	PUR0	ADCON0	Function
Bit	PD0_6	PU01	CH2, CH1, CH0, ADGSEL0	
Setting value	0	0	XXXX	Input port (not pulled up)
	0	1	XXXX	Input port (pulled up)
	0	0	00102	A/D input (AN1)
	1	X	XXXX	Output port

X: "0" or "1"

**Table 15.8 Port P07/AN0 Setting**

Register	PD0	PUR0	ADCON0	Function
Bit	PD0_7	PU01	CH2, CH1, CH0, ADGSEL0	
Setting value	0	0	XXXX	Input port (not pulled up)
	0	1	XXXX	Input port (pulled up)
	0	0	00002	A/D input (AN0)
	1	X	XXXX	Output port

X: "0" or "1"

**Table 15.9 Port P10/KI0/AN8/CMP00 Setting**

Register	PD1	PUR0	DRR	KIEN	ADCON0	TCOUT	Function
Bit	PD1_0	PU02	DRR0	KI0EN	CH2, CH1, CH0, ADGSEL0	TCOUT0	
Setting value	0	0	X	X	XXXX	0	Input port (not pulled up)
	0	1	X	X	XXXX	0	Input port (pulled up)
	0	0	X	1	XXXX	0	KI0 input
	0	0	X	X	10012	0	A/D input (AN8)
	1	X	0	X	XXXX	0	Output port
	1	X	1	X	XXXX	0	Output port (High drive)
	X	X	0	X	XXXX	1	CMP00 output
	X	X	1	X	XXXX	1	CMP00 output (High drive)

X: "0" or "1"

**Table 15.10 Port P11/ $\overline{KI1}$ /AN9/CMP01 Setting**

Register	PD1	PUR0	DRR	KIEN	ADCON0	TCOUT	Function
Bit	PD1_1	PU02	DRR1	KI1EN	CH2, CH1, CH0, ADGSEL0	TCOUT1	
Setting value	0	0	X	X	XXXX	0	Input port (not pulled up)
	0	1	X	X	XXXX	0	Input port (pulled up)
	0	0	X	1	XXXX	0	$\overline{KI1}$ input
	0	0	X	X	10112	0	A/D input (AN9)
	1	X	0	X	XXXX	0	Output port
	1	X	1	X	XXXX	0	Output port (High drive)
	X	X	0	X	XXXX	1	CMP01 output
	X	X	1	X	XXXX	1	CMP01 output (High drive)

X: "0" or "1"

**Table 15.11 Port P12/ $\overline{KI2}$ /AN10/CMP02 Setting**

Register	PD1	PUR0	DRR	KIEN	ADCON0	TCOUT	Function
Bit	PD1_2	PU02	DRR2	KI2EN	CH2, CH1, CH0, ADGSEL0	TCOUT2	
Setting value	0	0	X	X	XXXX	0	Input port (not pulled up)
	0	1	X	X	XXXX	0	Input port (pulled up)
	0	0	X	1	XXXX	0	$\overline{KI2}$ input
	0	0	X	X	11012	0	A/D input (AN10)
	1	X	0	X	XXXX	0	Output port
	1	X	1	X	XXXX	0	Output port (High drive)
	X	X	0	X	XXXX	1	CMP02 output
	X	X	1	X	XXXX	1	CMP02 output (High drive)

X: "0" or "1"

**Table 15.12 Port P13/ $\overline{KI3}$ /AN11 Setting**

Register	PD1	PUR0	DRR	KIEN	ADCON0	Function
Bit	PD1_3	PU02	DRR3	KI3EN	CH2, CH1, CH0, ADGSEL0	
Setting value	0	0	X	X	XXXX	Input port (not pulled up)
	0	1	X	X	XXXX	Input port (pulled up)
	0	0	X	1	XXXX	$\overline{KI3}$ input
	0	0	X	X	11112	A/D input (AN11)
	1	X	0	X	XXXX	Output port
	1	X	1	X	XXXX	Output port (High drive)

X: "0" or "1"

**Table 15.13 Port P14/TxD0 Setting**

Register	PD1	PUR0	DRR	U0MR	U0C0	Function
Bit	PD1_4	PU03	DRR4	SMD2, SMD0	NCH	
Setting value	0	0	X	002	X	Input port (not pulled up)
	0	1	X	002	X	Input port (pulled up)
	1	X	0	002	X	Output port
	1	X	1	002	X	Output port (High drive)
	X	X	0	X1 1X	0	TxD0 output, CMOS output
	X	X	1	X1 1X	0	TxD0 output, CMOS output (High drive)
	X	X	0	X1 1X	1	TxD0 output, N-channel open output
	X	X	1	X1 1X	1	TxD0 output, N-channel open output (High drive)

X: "0" or "1"

**Table 15.14 Port P15/RxD0 Setting**

Register	PD1	PUR0	DRR	Function
Bit	PD1_5	PU03	DRR5	
Setting value	0	0	X	Input port (not pulled up)
	0	1	X	Input port (pulled up)
	0	0	X	RxD0 input
	1	X	0	Output port
	1	X	1	Output port (High drive)

X: "0" or "1"

**Table 15.15 Port P16/CLK0 Setting**

Register	PD1	PUR0	DRR	U0MR	Function
Bit	PD1_6	PU03	DRR6	SMD2, SMD0, CKDIR	
Setting value	0	0	X	Other than 0102	Input port (not pulled up)
	0	1	X	Other than 0102	Input port (pulled up)
	0	0	X	XX1	CLK0 (external clock) input
	1	X	0	Other than 0102	Output port
	1	X	1	Other than 0102	Output port (High drive)
	X	X	0	0102	CLK0 (internal clock) output
	X	X	1	0102	CLK0 (internal clock) output (High drive)

X: "0" or "1"

**Table 15.16 Port P17/ $\overline{\text{INT}}_1/\text{CNTR}_0$  Setting**

Register	PD1	PUR0	DRR	TXMR	Function
Bit	PD1_7	PU03	DRR5	TXMOD1, TXMOD0	
Setting value	0	0	X	Other than 012	Input port (not pulled up)
	0	1	X	Other than 012	Input port (pulled up)
	0	0	X	Other than 012	CNTR <sub>0</sub> / $\overline{\text{INT}}_1$ input
	1	X	0	Other than 012	Output port
	1	X	1	Other than 012	Output port (High drive)
	X	X	0	012	CNTR <sub>0</sub> output
	X	X	1	012	CNTR <sub>0</sub> (High drive)

X: "0" or "1"

**Table 15.17 Port P30/ $\overline{\text{CNTR}}_0/\text{CMP1}_0$  Setting**

Register	PD3	PUR0	TXMR	TCOUT	Function
Bit	PD3_0	PU06	TXOCNT	TCOUT3	
Setting value	0	0	0	0	Input port (not pulled up)
	0	1	0	0	Input port (pulled up)
	1	X	0	0	Output port
	X	X	1	0	CNTR <sub>0</sub> output
	X	X	X	1	CMP <sub>10</sub> output

X: "0" or "1"

**Table 15.18 Port P31/ $\overline{\text{TZout}}/\text{CMP1}_1$  Setting**

Register	PD3	PUR0	TYZMR	TYZOC	TCOUT	Function
Bit	PD3_1	PU06	TZMOD1, TZMOD0	TZOCNT	TCOUT4	
Setting value	0	0	002	X	0	Input port (not pulled up)
			012	1		
	0	1	002	X	0	Input port (pulled up)
			012	1		
	1	X	002	X	0	Output port
			012	1		
	X	X	1X	X	0	TZOUT output
			012	0		
	X	X	XX	X	1	CMP <sub>11</sub> output

X: "0" or "1"

**Table 15.19 Port P32/ $\overline{\text{INT}}_2/\text{CNTR}_1/\text{CMP1}_2$  Setting**

Register	PD3	PUR0	TYZMR	TYZOC	TCOUT	Function
Bit	PD3_2	PU06	TYMOD1	TZOCNT	TCOUT5	
Setting value	0	0	0	1	0	Input port (not pulled up)
	0	1	0	1	0	Input port (pulled up)
	0	0	0	1	0	CNTR <sub>1</sub> / $\overline{\text{INT}}_2$ input
	1	X	0	1	0	Output port
	X	X	1	0	0	CNTR <sub>1</sub> output
	X	X	X	X	1	CMP <sub>12</sub> output

X: "0" or "1"



**Table 15.20 Port P33/ $\overline{\text{INT}}_3/\text{TCIN}$  Setting**

Register	PD3	PUR0	Function
Bit	PD3_3	PU06	
Setting value	0	0	Input port (not pulled up)
	0	1	Input port (pulled up)
	0	0	$\text{TCIN}/\overline{\text{INT}}_3$ input
	1	X	Output port

X: "0" or "1"

**Table 15.21 Port P37/ $\text{TxD}_{10}/\text{Rx}_{\text{D}1}$  Setting**

Register	PD3	PUR0	UCON	U1MR	U1C0	Function
Bit	PD3_7	PU07	TXD1EN	SMD2, SMD0	NCH	
Setting value	0	0	X	002	X	Input port (not pulled up)
	0	1	X	002	X	Input port (pulled up)
	0	0	0	1X	X	Rx <sub>D</sub> 1
				X1		
	1	X	X	002	X	Output port
	X	X	1	1X	0	Tx <sub>D</sub> 0 output, CMOS output
				X1		
X	X	1	1X	1	Tx <sub>D</sub> 10 output, N-channel open output	
			X1			

X: "0" or "1"

**Table 15.22 Port P45/ $\overline{\text{INT}}_0$  Setting**

Register	PD4	PUR1	INTEN	Function
Bit	PD4_5	PU11	INT0EN	
Setting value	0	0	0	Input port (not pulled up)
	0	1	0	Input port (pulled up)
	0	0	1	$\overline{\text{INT}}_0$ input
	1	X	X	Output port

X: "0" or "1"

**Table 15.23 Port X<sub>IN</sub>/P46, X<sub>OUT</sub>/P47 Setting**

Register	CM1	CM1	CM0	Circuit specification		Function
Bit	CM13	CM10	CM05	Oscillation buffer	Feedback resistance	
Setting value	1	1	1	OFF	OFF	X <sub>IN</sub> -X <sub>OUT</sub> oscillatoin stop
	1	0	1	OFF	ON	External input to X <sub>IN</sub> pin, "H" output from X <sub>OUT</sub> pin
	1	0	1	OFF	ON	X <sub>IN</sub> -X <sub>OUT</sub> oscillatoin stop
	1	0	0	ON	ON	X <sub>IN</sub> -X <sub>OUT</sub> oscillatoin
	0	X	X	OFF	OFF	Input port

X: "0" or "1"

### 15.3 Unassigned Pin Handling

Table 15.24 lists the handling of unassigned pins.

**Table 15.24 Unassigned Pin Handling**

Pin name	Connection
Ports P0, P1, P30 to P33, P37 P45	<ul style="list-style-type: none"> <li>•After setting for input mode, connect every pin to VSS via a resistor(pull-down) or connect every pin to VCC via a resistor(pull-up)</li> <li>•Set to output mode and leave these pins open<sup>(1, 2)</sup></li> </ul>
Ports P46, P47	Connect to VCC via resistor (pull-up) <sup>(2)</sup>
AVCC, VREF	Connect to VCC
AVSS	Connect to VSS
$\overline{\text{RESET}}$ <sup>(3)</sup>	Connect to VCC via a resistor (pull-up) <sup>(2)</sup>

**NOTES:**

1. When these ports are set for output mode and left open, they remain input mode until they are set for output mode by a program. The voltage level of these pins may be unstable and the power supply current may increase for the time the ports remain input mode. The content of the direction registers may change due to noise or runaway caused by noise. In order to enhance program reliability, set the direction registers periodically by a program.
2. Connect these unassigned pins to the microcomputer using the shortest wire length (within 2 cm) possible.
3. When power-on reset is used.

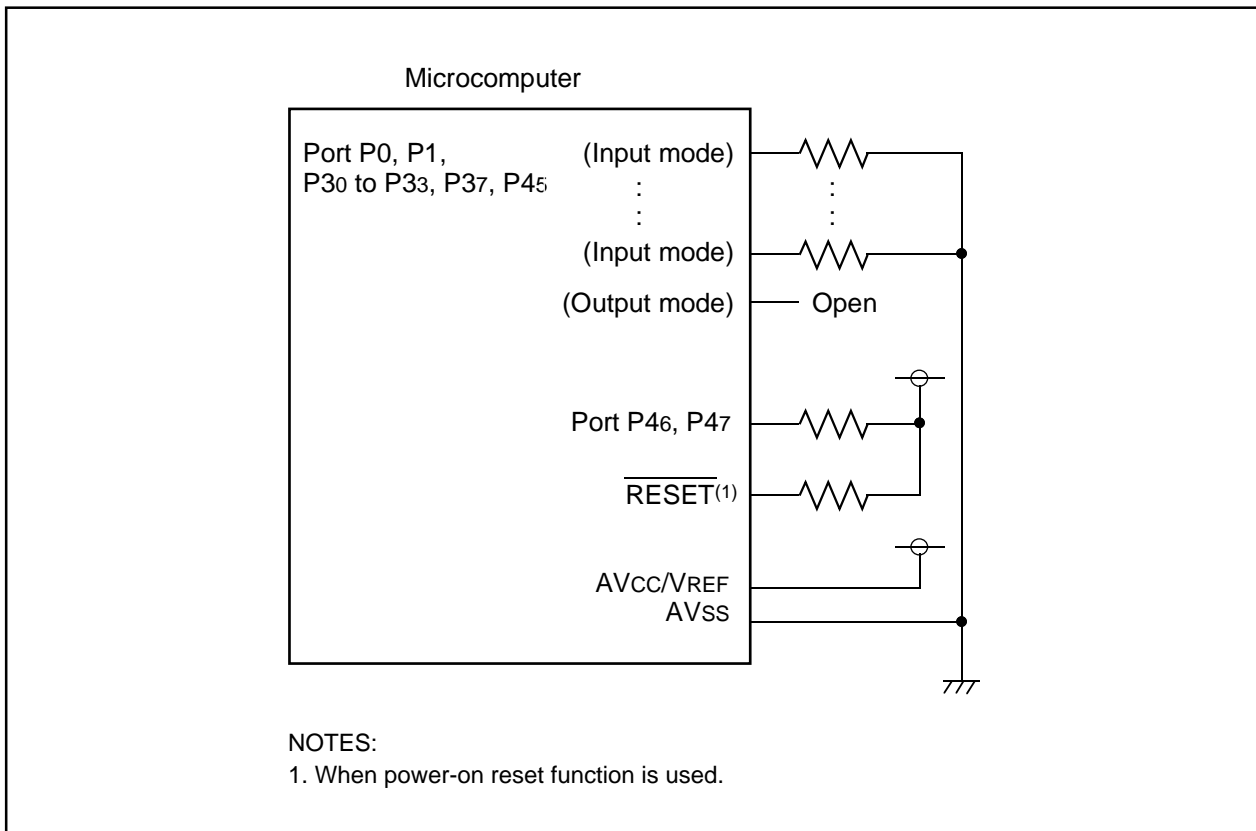

**Figure 15.10 Unassigned Pin Handling**

## 16. Electrical Characteristics

**Table 16.1 Absolute Maximum Ratings**

Symbol	Parameter	Condition	Rated value	Unit
V <sub>CC</sub>	Supply voltage	V <sub>CC</sub> =AV <sub>CC</sub>	-0.3 to 6.5	V
AV <sub>CC</sub>	Analog supply voltage	V <sub>CC</sub> =AV <sub>CC</sub>	-0.3 to 6.5	V
V <sub>I</sub>	Input voltage		-0.3 to V <sub>CC</sub> +0.3	V
V <sub>O</sub>	Output voltage		-0.3 to V <sub>CC</sub> +0.3	V
P <sub>d</sub>	Power dissipation	T <sub>opr</sub> =25 °C	300	mW
T <sub>opr</sub>	Operating ambient temperature		-20 to 85 / -40 to 85 (D version)	°C
T <sub>stg</sub>	Storage temperature		-65 to 150	°C

**Table 16.2 Recommended Operating Conditions**

Symbol	Parameter	Conditions	Standard			Unit	
			Min.	Typ.	Max.		
V <sub>CC</sub>	Supply voltage		2.7	—	5.5	V	
AV <sub>CC</sub>	Analog supply voltage		—	V <sub>CC</sub> ( <sup>3</sup> )	—	V	
V <sub>SS</sub>	Supply voltage		—	0	—	V	
AV <sub>SS</sub>	Analog supply voltage		—	0	—	V	
V <sub>IH</sub>	"H" input voltage		0.8V <sub>CC</sub>	—	V <sub>CC</sub>	V	
V <sub>IL</sub>	"L" input voltage		0	—	0.2V <sub>CC</sub>	V	
I <sub>OH</sub> (sum)	"H" peak all output currents	Sum of all pins' IOH (peak)	—	—	-60.0	mA	
I <sub>OH</sub> (peak)	"H" peak output current		—	—	-10.0	mA	
I <sub>OH</sub> (avg)	"H" average output current		—	—	-5.0	mA	
I <sub>OL</sub> (sum)	"L" peak all output currents	Sum of all pins' IOL (peak)	—	—	60	mA	
I <sub>OL</sub> (peak)	"L" peak output current	Except P1 <sub>0</sub> to P1 <sub>7</sub>	—	—	10	mA	
		P1 <sub>0</sub> to P1 <sub>7</sub>	Drive capacity HIGH	—	—	30	mA
			Drive capacity LOW	—	—	10	mA
I <sub>OL</sub> (avg)	"L" average output current	Except P1 <sub>0</sub> to P1 <sub>7</sub>	—	—	5	mA	
		P1 <sub>0</sub> to P1 <sub>7</sub>	Drive capacity HIGH	—	—	15	mA
			Drive capacity LOW	—	—	5	mA
f (XIN)	Main clock input oscillation frequency	3.0V ≤ V <sub>CC</sub> ≤ 5.5V	0	—	20	MHz	
		2.7V ≤ V <sub>CC</sub> < 3.0V	0	—	10	MHz	

**NOTES:**

1. V<sub>CC</sub> = AV<sub>CC</sub> = 2.7 to 5.5V at T<sub>opr</sub> = -20 to 85 °C / -40 to 85 °C, unless otherwise specified.
2. The typical values when average output current is 100ms.
3. Hold V<sub>CC</sub>=AV<sub>CC</sub>.

Table 16.3 A/D Conversion Characteristics

Symbol	Parameter		Measuring condition	Standard			Unit
				Min.	Typ.	Max.	
—	Resolution		$V_{ref} = V_{CC}$	—	—	10	Bit
—	Absolute accuracy	10 bit mode	$\phi_{AD} = 10 \text{ MHz}$ , $V_{ref} = V_{CC} = 5.0 \text{ V}$	—	—	$\pm 3$	LSB
		8 bit mode	$\phi_{AD} = 10 \text{ MHz}$ , $V_{ref} = V_{CC} = 5.0 \text{ V}$	—	—	$\pm 2$	LSB
		10 bit mode	$\phi_{AD} = 10 \text{ MHz}$ , $V_{ref} = V_{CC} = 3.3 \text{ V}^{(3)}$	—	—	$\pm 5$	LSB
		8 bit mode	$\phi_{AD} = 10 \text{ MHz}$ , $V_{ref} = V_{CC} = 3.3 \text{ V}^{(3)}$	—	—	$\pm 2$	LSB
$R_{LADDER}$	Ladder resistance		$V_{REF} = V_{CC}$	10	—	40	$k\Omega$
$t_{CONV}$	Conversion time	10 bit mode	$\phi_{AD} = 10 \text{ MHz}$ , $V_{ref} = V_{CC} = 5.0 \text{ V}$	3.3	—	—	$\mu\text{s}$
		8 bit mode	$\phi_{AD} = 10 \text{ MHz}$ , $V_{ref} = V_{CC} = 5.0 \text{ V}$	2.8	—	—	$\mu\text{s}$
$V_{REF}$	Reference voltage			—	$V_{CC}^{(4)}$	—	V
$V_{IA}$	Analog input voltage			0	—	$V_{ref}$	V
—	A/D operating clock frequency <sup>(2)</sup>	Without sample & hold		0.25	—	10	MHz
		With sample & hold		1.0	—	10	MHz

## NOTES:

- $V_{CC} = AV_{CC} = 2.7$  to  $5.5 \text{ V}$  at  $T_{opr} = -20$  to  $85 \text{ }^\circ\text{C}$  /  $-40$  to  $85 \text{ }^\circ\text{C}$ , unless otherwise specified.
- If  $f_{AD}$  exceeds 10 MHz more, divide the  $f_{AD}$  and hold A/D operating clock frequency ( $\phi_{AD}$ ) 10 MHz or below.
- If the  $AV_{CC}$  is less than 4.2V, divide the  $f_{AD}$  and hold A/D operating clock frequency ( $\phi_{AD}$ )  $f_{AD}/2$  or below.
- Hold  $V_{CC} = V_{ref}$ .

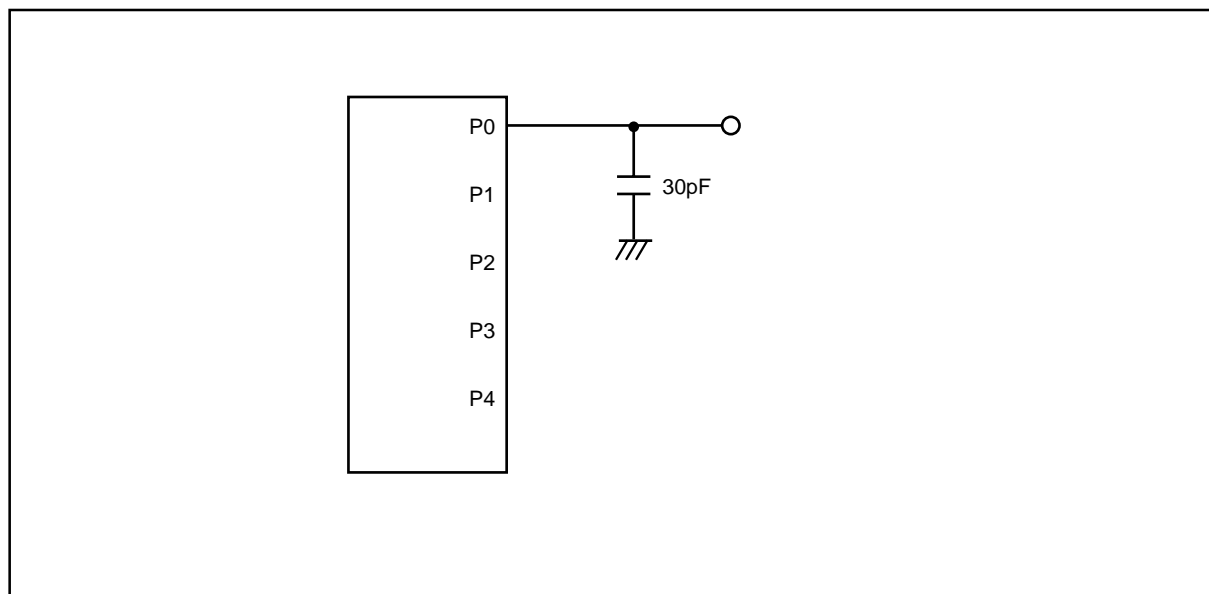

Figure 16.1 Port P0 to P4 measurement circuit

**Table 16.4 Flash Memory Version Electrical Characteristics**

Symbol	Parameter	Measuring condition	Standard			Unit
			Min.	Typ.	Max.	
—	Program/erase endurance		100	—	—	times
—	Byte program time		—	50	400	μs
—	Block erase time		—	0.4	9	s
td(SR-ES)	Time delay from suspend request until erase suspend		—	—	8	ms
—	Erase Suspend Request Interval		10	—	—	ms
—	Program, Erase voltage		2.7	—	5.5	V
—	Read voltage		2.7	—	5.5	V
—	Program, Erase temperature		0	—	60	°C
—	Data hold time <sup>(2)</sup>	Ambient temperature=55 °C	20	—	—	year

## NOTES:

1. Referenced to  $V_{CC1}=AV_{CC}=2.7$  to  $5.5V$  at  $T_{opr} = 0$  to  $60$  °C unless otherwise specified.
2. The data hold time includes time that the power supply is off or the clock is not supplied.

**Table 16.5 Voltage Detection Circuit Electrical Characteristics**

Symbol	Parameter	Measuring condition	Standard			Unit
			Min.	Typ.	Max.	
Vdet	Voltage detection level		3.3	3.8	4.3	V
—	Voltage detection interrupt request generating time <sup>(2)</sup>		—	40	—	μs
—	Voltage detection circuit self consumption current	VC27=1, VCC=5.0V	—	600	—	nA
td(E-A)	Waiting time till voltage detection circuit operation starts <sup>(3)</sup>		—	—	20	μs
Vccmin	Minimum value of microcomputer operation voltage		2.7	—	—	V

## NOTES:

1. The measuring condition is  $V_{CC}=AV_{CC}=2.7V$  to  $5.5V$  and  $T_{opr}=-40$ °C to  $85$  °C.
2. This shows the time until the voltage detection interrupt request is generated since the voltage passes Vdet.
3. This shows the required time until the voltage detection circuit operates when setting to "1" again after setting the VC27 bit in the VCR2 register to "0".

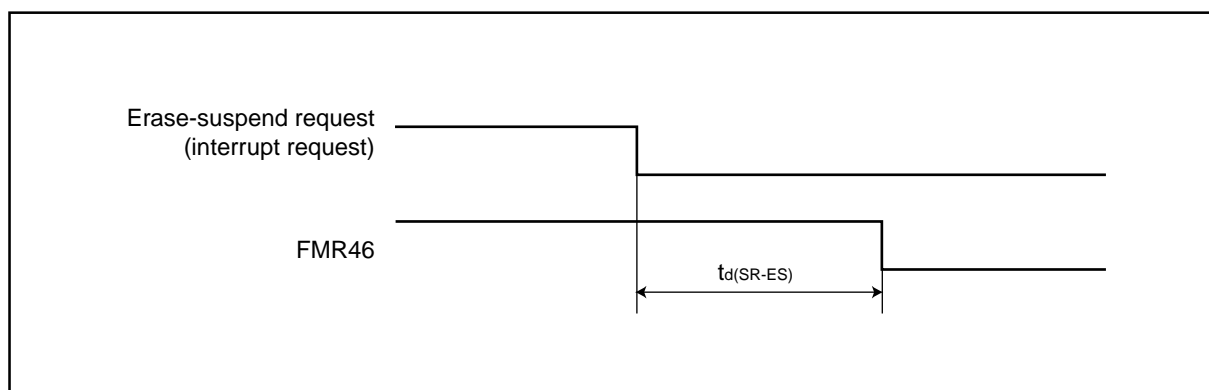
**Figure 16.2 Time delay from Suspend Request until Erase Suspend**

**Table 16.6 Reset Circuit Electrical Characteristics (When Using Hardware Reset 2<sup>(1, 3)</sup>)**

Symbol	Parameter	Measuring condition	Standard			Unit
			Min.	Typ.	Max.	
Vpor2	Power-on reset valid voltage	-20°C ≤ Topr < 85°C	—	—	Vdet	V
tw(Vpor2-Vdet)	Supply voltage rising time when power-on reset is canceled <sup>(2)</sup>	-20°C ≤ Topr < 85°C, tw(por2) ≥ 0s <sup>(4)</sup>	—	—	100	ms

## NOTES:

1. The voltage detection circuit which is embedded in a microcomputer is a factor to generate the hardware reset 2. Refer to 5.1.2 Hardware Reset 2.
2. This condition is not applicable when using with Vcc ≥ 1.0V.
3. When turning power on after the external power has been held below the valid voltage (Vpor1) for greater than 10 seconds, refer to Table 16.7 Reset Circuit Electrical Characteristics (When Not Using Hardware Reset 2).
4. tw(por2) is time to hold the external power below effective voltage (Vpor2).

**Table 16.7 Reset Circuit Electrical Characteristics (When Not Using Hardware Reset 2)**

Symbol	Parameter	Measuring condition	Standard			Unit
			Min.	Typ.	Max.	
Vpor1	Power-on reset valid voltage	-20°C ≤ Topr < 85°C	—	—	0.1	V
tw(Vpor1-Vdet)	Supply voltage rising time when power-on reset is canceled	0°C ≤ Topr ≤ 85°C, tw(por1) ≥ 10s <sup>(2)</sup>	—	—	100	ms
tw(Vpor1-Vdet)	Supply voltage rising time when power-on reset is canceled	-20°C ≤ Topr < 0°C, tw(por1) ≥ 30s <sup>(2)</sup>	—	—	100	ms
tw(Vpor1-Vdet)	Supply voltage rising time when power-on reset is canceled	-20°C ≤ Topr < 0°C, tw(por1) ≥ 10s <sup>(2)</sup>	—	—	1	ms
tw(Vpor1-Vdet)	Supply voltage rising time when power-on reset is canceled	0°C ≤ Topr ≤ 85°C, tw(por1) ≥ 1s <sup>(2)</sup>	—	—	0.5	ms

## NOTES:

1. When not using hardware reset 2, use with Vcc ≥ 2.7V.
2. tw(por1) is time to hold the external power below effective voltage (Vpor1).

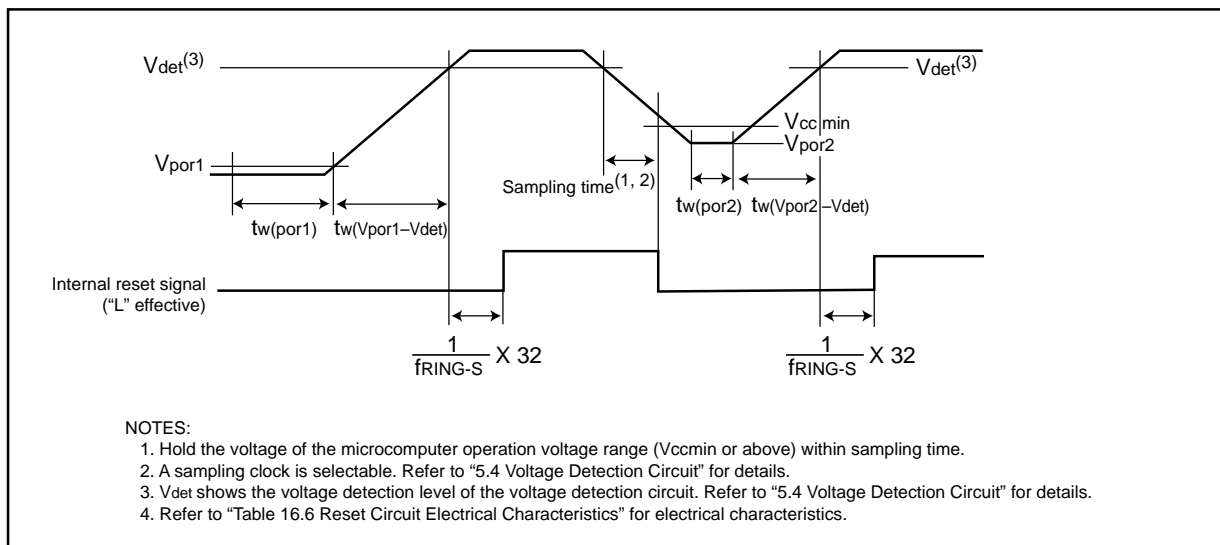
**Figure 16.3 Reset Circuit Electrical Characteristics**

**Table 16.8 High-speed On-Chip Oscillator Circuit Electrical Characteristics**

Symbol	Parameter	Measuring condition	Standard			Unit
			Min.	Typ.	Max.	
—	High-speed on-chip oscillator frequency 1 / (td(HRoffset)+td(HR)) when the reset is released	VCC=5.0V, Topr=25 °C Set "4016" in the HR1 register	6	8	10	MHz
td(HRoffset)	Settable high-speed on-chip oscillator minimum period	VCC=5.0V, Topr=25 °C Set "0016" in the HR1 register	—	61	—	ns
td(HR)	High-speed on-chip oscillator period adjusted unit	Differences when setting "0116" and "0016" in the HR register	—	1	—	ns
—	High-speed on-chip oscillator frequency temperature dependence(1)	Frequency fluctuation in temperature range of -10 °C to 50 °C	—	±5	—	%
—	High-speed on-chip oscillator frequency temperature dependence(2)	Frequency fluctuation in temperature range of -40 °C to 85 °C	—	±10	—	%

## NOTES:

1. The measuring condition is Vcc=AVcc=5.0 V and Topr=25 °C.

**Table 16.9 Power Circuit Timing Characteristics**

Symbol	Parameter	Measuring condition	Standard			Unit
			Min.	Typ.	Max.	
td(P-R)	Time for internal power supply stabilization during powering-on <sup>(2)</sup>		1	—	2000	μs
td(R-S)	STOP release time <sup>(3)</sup>		—	—	150	μs

## NOTES:

1. The measuring condition is Vcc=AVcc=2.7 to 5.5 V and Topr=25 °C.
2. This shows the wait time until the internal power supply generating circuit is stabilized during power-on.
3. This shows the time until CPU clock supply starts from the interrupt acknowledgement to cancel stop mode.

**Table 16.10 Electrical Characteristics (1) [Vcc=5V]**

Symbol	Parameter		Measuring condition	Standard			Unit	
				Min.	Typ.	Max.		
VOH	"H" output voltage	Except XOUT	I <sub>OH</sub> =-5mA	Vcc-2.0	—	Vcc	V	
			I <sub>OH</sub> =-200μA	Vcc-0.3	—	Vcc	V	
		XOUT	Drive ability HIGH	I <sub>OH</sub> =-1 mA	Vcc-2.0	—	Vcc	V
			Drive ability LOW	I <sub>OH</sub> =-500μA	Vcc-2.0	—	Vcc	V
VOL	"L" output voltage	Except P10 to P17, XOUT	I <sub>OL</sub> = 5 mA	—	—	2.0	V	
			I <sub>OL</sub> = 200 μA	—	—	0.45	V	
		P10 to P17	Drive capacity HIGH	I <sub>OL</sub> = 15 mA	—	—	2.0	V
			Drive capacity LOW	I <sub>OL</sub> = 5 mA	—	—	2.0	V
			Drive capacity LOW	I <sub>OL</sub> = 200 μA	—	—	0.45	V
		XOUT	Drive capacity HIGH	I <sub>OL</sub> = 1 mA	—	—	2.0	V
			Drive capacity LOW	I <sub>OL</sub> =500 μA	—	—	2.0	V
VT+·VT-	Hysteresis	INT0, INT1, INT2, INT3, KI0, KI1, KI2, KI3, CNTR0, CNTR1, TCIN, RxD0, RxD1, P45		0.2	—	1.0	V	
		RESET		0.2	—	2.2	V	
I <sub>IH</sub>	"H" input current		V <sub>I</sub> =5V	—	—	5.0	μA	
I <sub>IL</sub>	"L" input current		V <sub>I</sub> =0V	—	—	-5.0	μA	
R <sub>PULLUP</sub>	Pull-up resistance		V <sub>I</sub> =0V	30	50	167	kΩ	
R <sub>XIN</sub>	Feedback resistance	XIN		—	1.0	—	MΩ	
f <sub>RING-S</sub>	Low-speed on-chip oscillator frequency			40	125	250	kHz	
V <sub>RAM</sub>	RAM retention voltage		At stop mode	2.0	—	—	V	

## NOTES:

1. Referenced to Vcc = AVcc = 4.2 to 5.5V at Topr = -20 to 85 °C / -40 to 85 °C, f(XIN)=20MHz unless otherwise specified.

Table 16.11 Electrical Characteristics (2) [Vcc=5V]

Symbol	Parameter	Measuring condition	Standard			Unit	
			Min.	Typ.	Max.		
I <sub>CC</sub>	Power supply current (V <sub>CC</sub> =3.3 to 5.5V) In single-chip mode, the output pins are open and other pins are V <sub>SS</sub>	High-speed mode X <sub>IN</sub> =20 MHz (square wave) High-speed on-chip oscillator off Low-speed on-chip oscillator on=125 kHz No division	—	9	15	mA	
			X <sub>IN</sub> =16 MHz (square wave) High-speed on-chip oscillator off Low-speed on-chip oscillator on=125 kHz No division	—	8	14	mA
				X <sub>IN</sub> =10 MHz (square wave) High-speed on-chip oscillator off Low-speed on-chip oscillator on=125 kHz No division	—	5	—
		Medium-speed mode X <sub>IN</sub> =20 MHz (square wave) High-speed on-chip oscillator off Low-speed on-chip oscillator on=125 kHz Division by 8	—		4	—	mA
			X <sub>IN</sub> =16 MHz (square wave) High-speed on-chip oscillator off Low-speed on-chip oscillator on=125 kHz Division by 8	—	3	—	mA
				X <sub>IN</sub> =10 MHz (square wave) High-speed on-chip oscillator off Low-speed on-chip oscillator on=125 kHz Division by 8	—	2	—
		High-speed on-chip oscillator mode Main clock off High-speed on-chip oscillator on=8 MHz Low-speed on-chip oscillator on=125 kHz No division	—		4	8	mA
			Main clock off High-speed on-chip oscillator on=8 MHz Low-speed on-chip oscillator on=125 kHz Division by 8	—	1.5	—	mA
		Low-speed on-chip oscillator mode Main clock off High-speed on-chip oscillator off Low-speed on-chip oscillator on=125 kHz Division by 8		—	470	900	μA
			Wait mode Main clock off High-speed on-chip oscillator off Low-speed on-chip oscillator on=125 kHz When a WAIT instruction is executed <sup>(1)</sup> Peripheral clock operation VC27="0"	—	40	80	μA
		Wait mode Main clock off High-speed on-chip oscillator off Low-speed on-chip oscillator on=125 kHz When a WAIT instruction is executed <sup>(1)</sup> Peripheral clock off VC27="0"		—	38	76	μA
			Stop mode Main clock off, Topr = 25 °C High-speed on-chip oscillator off Low-speed on-chip oscillator off CM10="1" Peripheral clock off VC27="0"	—	0.8	3.0	μA

## NOTES:

1. Timer Y is operated with timer mode.
2. Referenced to V<sub>CC</sub> = AV<sub>CC</sub> = 4.2 to 5.5V at Topr = -20 to 85 °C / -40 to 85 °C, f(X<sub>IN</sub>)=20MHz unless otherwise specified.



**Timing requirements (Unless otherwise noted:  $V_{CC} = 5V$ ,  $V_{SS} = 0V$  at  $T_{opr} = 25\text{ }^{\circ}C$ ) [ $V_{CC}=5V$ ]****Table 16.12 XIN input**

Symbol	Parameter	Standard		Unit
		Min.	Max.	
tC(XIN)	XIN input cycle time	50	–	ns
tWH(XIN)	XIN input HIGH pulse width	25	–	ns
tWL(XIN)	XIN input LOW pulse width	25	–	ns

**Table 16.13 CNTR0 input, CNTR1 input,  $\overline{INT2}$  input**

Symbol	Parameter	Standard		Unit
		Min.	Max.	
tC(CNTR0)	CNTR0 input cycle time	100	–	ns
tWH(CNTR0)	CNTR0 input HIGH pulse width	40	–	ns
tWL(CNTR0)	CNTR0 input LOW pulse width	40	–	ns

**Table 16.14 TCIN input,  $\overline{INT3}$  input**

Symbol	Parameter	Standard		Unit
		Min.	Max.	
tC(TCIN)	TCIN input cycle time	400 <sup>(1)</sup>	–	ns
tWH(TCIN)	TCIN input HIGH pulse width	200 <sup>(2)</sup>	–	ns
tWL(TCIN)	TCIN input LOW pulse width	200 <sup>(2)</sup>	–	ns

## NOTES:

1. When using the Timer C input capture mode, adjust the cycle time above ( 1/ Timer C count source frequency x 3).
2. When using the Timer C input capture mode, adjust the pulse width above ( 1/ Timer C count source frequency x 1.5).

**Table 16.15 Serial Interface**

Symbol	Parameter	Standard		Unit
		Min.	Max.	
tC(CK)	CLKi input cycle time	200	–	ns
tW(CKH)	CLKi input HIGH pulse width	100	–	ns
tW(CKL)	CLKi input LOW pulse width	100	–	ns
td(C-Q)	TxDi output delay time	–	80	ns
th(C-Q)	TxDi hold time	0	–	ns
tsu(D-C)	RxDi input setup time	35	–	ns
th(C-D)	RxDi input hold time	90	–	ns

**Table 16.16 External interrupt  $\overline{INT0}$  input**

Symbol	Parameter	Standard		Unit
		Min.	Max.	
tW(INH)	$\overline{INT0}$ input HIGH pulse width	250 <sup>(1)</sup>	–	ns
tW(INL)	$\overline{INT0}$ input LOW pulse width	250 <sup>(2)</sup>	–	ns

## NOTES:

1. When selecting the digital filter by the  $\overline{INT0}$  input filter select bit, use the  $\overline{INT0}$  input HIGH pulse width to the greater value, either ( 1/ digital filter clock frequency x 3) or the minimum value of standard.
2. When selecting the digital filter by the  $\overline{INT0}$  input filter select bit, use the  $\overline{INT0}$  input LOW pulse width to the greater value, either ( 1/ digital filter clock frequency x 3) or the minimum value of standard.

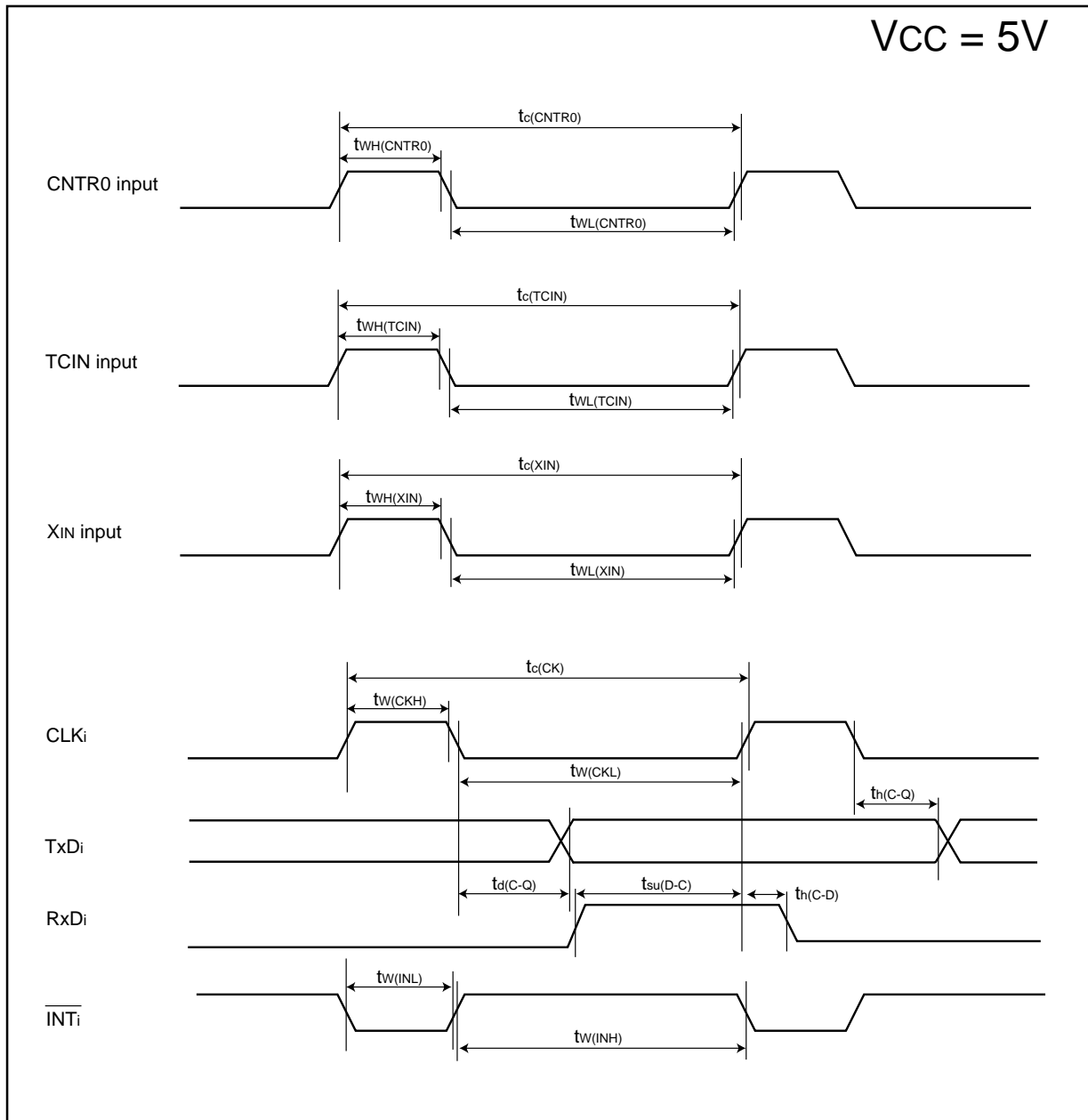

Figure 16.4  $V_{CC}=5V$  timing diagram

**Table 16.17 Electrical Characteristics (3) [Vcc=3V]**

Symbol	Parameter		Measuring condition		Standard			Unit
					Min.	Typ.	Max.	
VOH	"H" output voltage	Except XOUT	IOH=-1mA		Vcc-0.5	—	Vcc	V
		XOUT	Drive capacity HIGH	IOH=-0.1 mA	Vcc-0.5	—	Vcc	v
			Drive capacity LOW	IOH=-50 μA	Vcc-0.5	—	Vcc	v
VOL	"L" output voltage	Except P10 to P17, XOUT	IOL= 1 mA		—	—	0.5	V
		P10 to P17	Drive capacity HIGH	IOL= 2 mA	—	—	0.5	V
			Drive capacity LOW	IOL= 1 mA	—	—	0.5	v
		XOUT	Drive capacity HIGH	IOL= 0.1 mA	—	—	0.5	v
			Drive capacity LOW	IOL=50 μA	—	—	0.5	v
VT+-VT-	Hysteresis	INT0, INT1, INT2, INT3, K10, K11, K12, K13, CNTR0, CNTR1, TCIN, RxD0, RxD1, P45			0.2	—	0.8	v
		RESET			0.2	—	1.8	v
IiH	"H" input current			Vi=3V	—	—	4.0	μA
IiL	"L" input current			Vi=0V	—	—	-4.0	μA
RPULLUP	Pull-up resistance			Vi=0V	66	160	500	kΩ
RiXIN	Feedback resistance	XIN			—	3.0	—	MΩ
fRING-S	Low-speed on-chip oscillator frequency				40	125	250	kHz
V <sub>RAM</sub>	RAM retention voltage		At stop mode		2.0	—	—	V

## NOTES:

1. Referenced to Vcc = AVcc = 2.7 to 3.3V at Topr = -20 to 85 °C / -40 to 85 °C, f(XIN)=10MHz unless otherwise specified.

**Table 16.18 Electrical Characteristics (4) [Vcc=3V]**

Symbol	Parameter	Measuring condition	Standard			Unit
			Min.	Typ.	Max.	
I <sub>CC</sub>	Power supply current (V <sub>CC</sub> =2.7 to 3.3V) In single-chip mode, the output pins are open and other pins are V <sub>SS</sub>	High-speed mode X <sub>IN</sub> =20 MHz (square wave) High-speed on-chip oscillator off Low-speed on-chip oscillator on=125 kHz No division	—	8	13	mA
		X <sub>IN</sub> =16 MHz (square wave) High-speed on-chip oscillator off Low-speed on-chip oscillator on=125 kHz No division	—	7	12	mA
		X <sub>IN</sub> =10 MHz (square wave) High-speed on-chip oscillator off Low-speed on-chip oscillator on=125 kHz No division	—	5	—	mA
		Medium-speed mode X <sub>IN</sub> =20 MHz (square wave) High-speed on-chip oscillator off Low-speed on-chip oscillator on=125 kHz Division by 8	—	3	—	mA
		X <sub>IN</sub> =16 MHz (square wave) High-speed on-chip oscillator off Low-speed on-chip oscillator on=125 kHz Division by 8	—	2.5	—	mA
		X <sub>IN</sub> =10 MHz (square wave) High-speed on-chip oscillator off Low-speed on-chip oscillator on=125 kHz Division by 8	—	1.6	—	mA
		High-speed on-chip oscillator mode Main clock off High-speed on-chip oscillator on=8 MHz Low-speed on-chip oscillator on=125 kHz No division	—	3.5	7.5	mA
		Main clock off High-speed on-chip oscillator on=8 MHz Low-speed on-chip oscillator on=125 kHz Division by 8	—	1.5	—	mA
		Low-speed on-chip oscillator mode Main clock off High-speed on-chip oscillator off Low-speed on-chip oscillator on=125 kHz Division by 8	—	420	800	μA
		Wait mode Main clock off High-speed on-chip oscillator off Low-speed on-chip oscillator on=125 kHz When a WAIT instruction is executed <sup>(1)</sup> Peripheral clock operation VC27="0"	—	37	74	μA
Wait mode Main clock off High-speed on-chip oscillator off Low-speed on-chip oscillator on=125 kHz When a WAIT instruction is executed <sup>(1)</sup> Peripheral clock off VC27="0"	—	35	70	μA		
Stop mode Main clock off, T <sub>OPR</sub> = 25 °C High-speed on-chip oscillator off Low-speed on-chip oscillator off CM10="1" Peripheral clock off VC27="0"	—	0.7	3.0	μA		

## NOTES:

1. Timer Y is operated with timer mode.
2. Referenced to V<sub>CC</sub> = AV<sub>CC</sub> = 2.7 to 3.3V at T<sub>OPR</sub> = -20 to 85 °C / -40 to 85 °C, f(X<sub>IN</sub>)=10MHz unless otherwise specified.

**Timing requirements (Unless otherwise noted: Vcc = 3V, Vss = 0V at Topr = 25 °C) [Vcc=3V]****Table 16.19 XIN input**

Symbol	Parameter	Standard		Unit
		Min.	Max.	
tC(XIN)	XIN input cycle time	100	–	ns
tWH(XIN)	XIN input HIGH pulse width	40	–	ns
tWL(XIN)	XIN input LOW pulse width	40	–	ns

**Table 16.20 CNTR0 input, CNTR1 input, INT2 input**

Symbol	Parameter	Standard		Unit
		Min.	Max.	
tC(CNTR0)	CNTR0 input cycle time	300	–	ns
tWH(CNTR0)	CNTR0 input HIGH pulse width	120	–	ns
tWL(CNTR0)	CNTR0 input LOW pulse width	120	–	ns

**Table 16.21 TCIN input, INT3 input**

Symbol	Parameter	Standard		Unit
		Min.	Max.	
tC(TCIN)	TCIN input cycle time	1200 <sup>(1)</sup>	–	ns
tWH(TCIN)	TCIN input HIGH pulse width	600 <sup>(2)</sup>	–	ns
tWL(TCIN)	TCIN input LOW pulse width	600 <sup>(2)</sup>	–	ns

**NOTES:**

1. When using the Timer C input capture mode, adjust the cycle time above ( 1/ Timer C count source frequency x 3).
2. When using the Timer C input capture mode, adjust the pulse width above ( 1/ Timer C count source frequency x 1.5).

**Table 16.22 Serial Interface**

Symbol	Parameter	Standard		Unit
		Min.	Max.	
tC(CLK)	CLKi input cycle time	300	–	ns
tW(CLKH)	CLKi input HIGH pulse width	150	–	ns
tW(CLKL)	CLKi input LOW pulse width	150	–	ns
td(C-Q)	TxDi output delay time	–	160	ns
th(C-Q)	TxDi hold time	0	–	ns
tsu(D-C)	RxDi input setup time	55	–	ns
th(C-D)	RxDi input hold time	90	–	ns

**Table 16.23 External interrupt INT0 input**

Symbol	Parameter	Standard		Unit
		Min.	Max.	
tW(INH)	INT0 input HIGH pulse width	380 <sup>(1)</sup>	–	ns
tW(INL)	INT0 input LOW pulse width	380 <sup>(2)</sup>	–	ns

**NOTES:**

1. When selecting the digital filter by the INT0 input filter select bit, use the INT0 input HIGH pulse width to the greater value, either ( 1/ digital filter clock frequency x 3) or the minimum value of standard.
2. When selecting the digital filter by the INT0 input filter select bit, use the INT0 input LOW pulse width to the greater value, either ( 1/ digital filter clock frequency x 3) or the minimum value of standard.

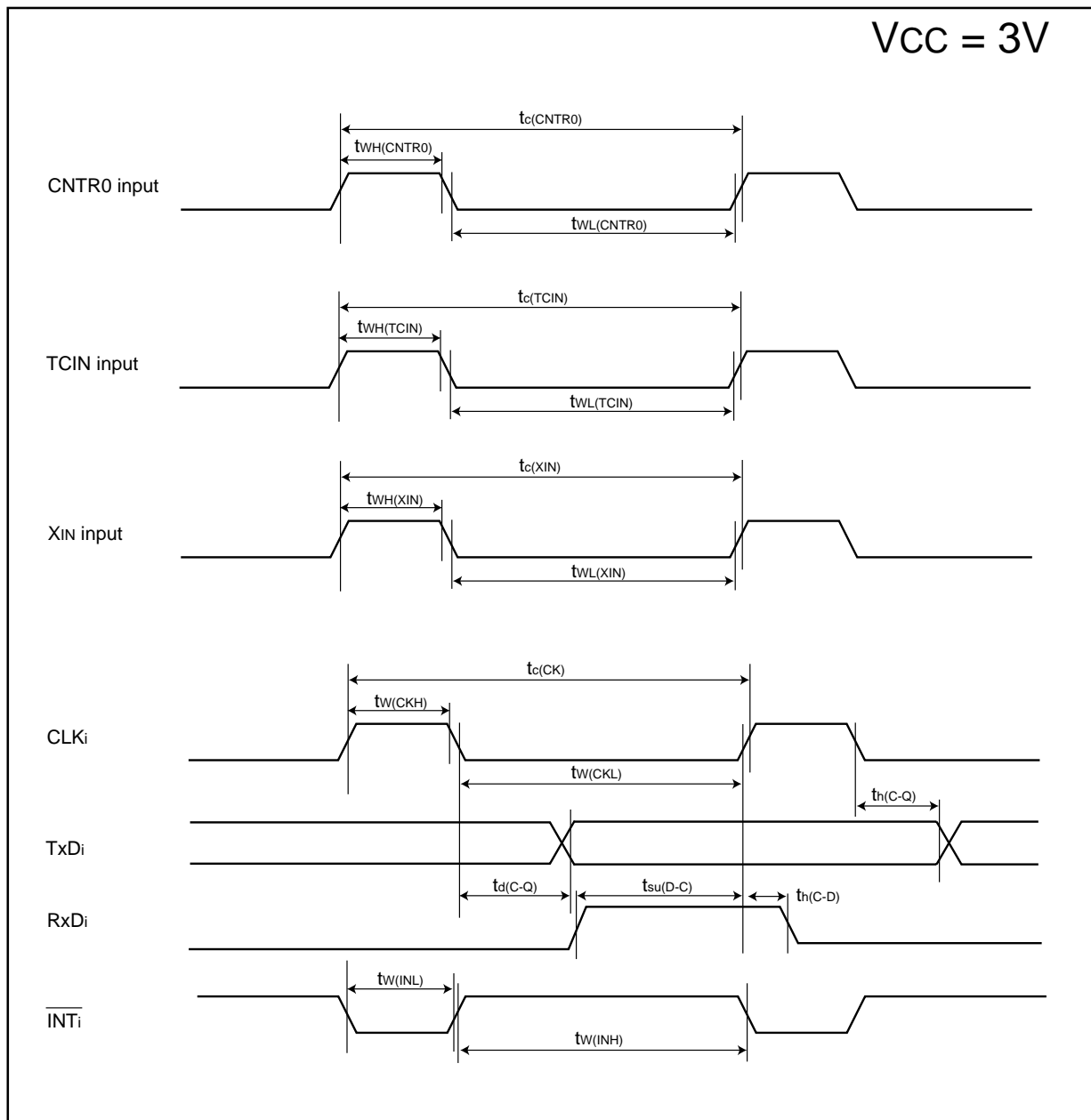

Figure 16.5 Vcc=3V timing diagram

## 17. Flash Memory Version

### 17.1 Overview

The flash memory version has two modes—CPU rewrite and standard serial I/O—in which its flash memory can be operated on.

Table 17.1 outlines the performance of flash memory version (see “Table 1.1 Performance” for the items not listed on Table 17.1).

**Table 17.1 Flash Memory Version Performance**

Item	Specification
Flash memory operating mode	2 modes (CPU rewrite and standard serial I/O)
Erase block	See “Figure 17.1. Flash Memory Block Diagram”
Method for program	In units of byte
Method for erasure	Block erase
Program, erase control method	Program and erase controlled by software command
Protect method	Blocks 0 and 1 protected by block 0, 1 program enable bit
Number of commands	5 commands
Number of program and erasure	100 times
ROM code protection	Standard serial I/O mode is supported.

**Table 17.2 Flash Memory Rewrite Modes**

Flash memory rewrite mode	CPU rewrite mode	Standard serial I/O mode
Function	User ROM area is rewritten by executing software commands from the CPU. EW0 mode: Can be rewritten in any area other than the flash memory EW1 mode: Can be rewritten in the flash memory	User ROM area is rewritten by using a dedicated serial programmer. Standard serial I/O mode 1 : Clock synchronous serial I/O Standard serial I/O mode 2 : UART
Areas which can be rewritten	User ROM area	User ROM area
Operation mode	Single chip mode	Boot mode
ROM programmer	None	Serial programmer

## 17.2 Memory Map

The ROM in the flash memory version is separated between a user ROM area and a boot ROM area (reserved area). Figure 17.1 shows the block diagram of flash memory.

The user ROM area is divided into several blocks. The user ROM area can be rewritten in CPU rewrite and standard serial input/output modes. Block 1 and Block 0 are enabled for rewrite in CPU rewrite mode by setting the FMR02 bit in the FMR0 register to "1" (rewrite enabled).

The rewrite program for standard serial I/O mode is stored in the boot ROM area before shipment. The boot ROM area and the user ROM area share the same address, but have an another memory.

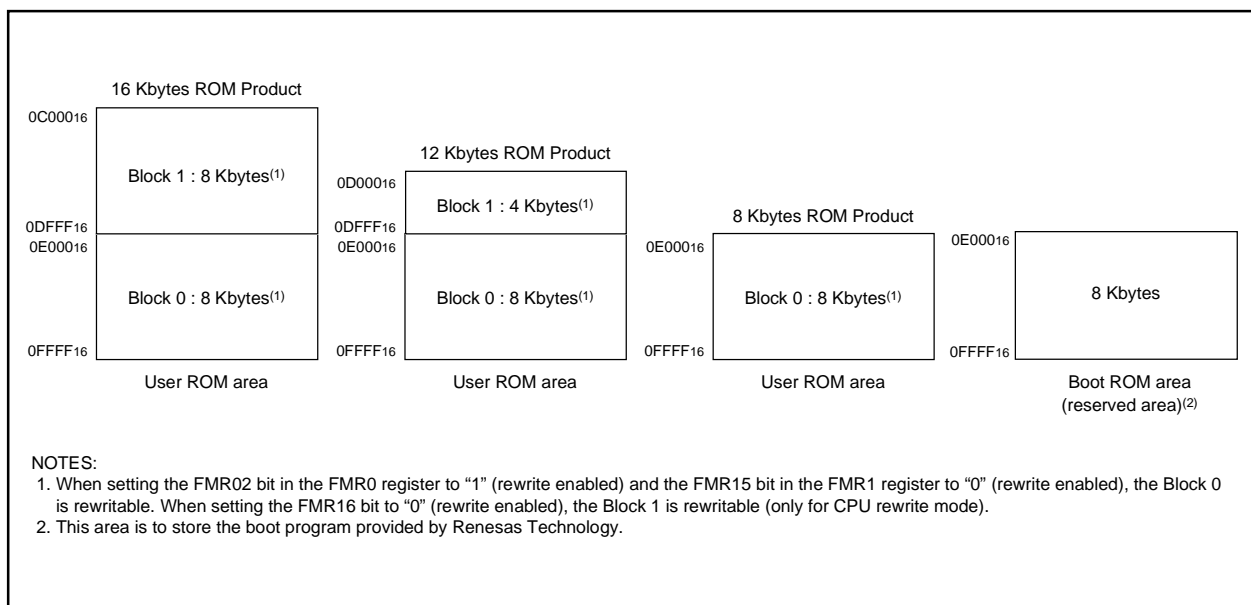

**Figure 17.1 Flash Memory Block Diagram**



## 17.3 Functions To Prevent Flash Memory from Rewriting

To prevent the flash memory from being read or rewritten easily, standard serial I/O mode has an ID code check function.

### 17.3.1 ID Code Check Function

Use this function in standard serial I/O mode. Unless the flash memory is blank, the ID codes sent from the programmer and the ID codes written in the flash memory are compared to see if they match. If the ID codes do not match, the commands sent from the programmer are not accepted. The ID code consists of 8-bit data, the areas of which, beginning with the first byte, are 00FFDF<sub>16</sub>, 00FFE3<sub>16</sub>, 00FFE7<sub>16</sub>, 00FFEB<sub>16</sub>, 00FFEF<sub>16</sub>, 00FFF3<sub>16</sub>, 00FFF7<sub>16</sub>, and 00FFFB<sub>16</sub>. Prepare a program in which the ID codes are preset at these addresses and write it in the flash memory.

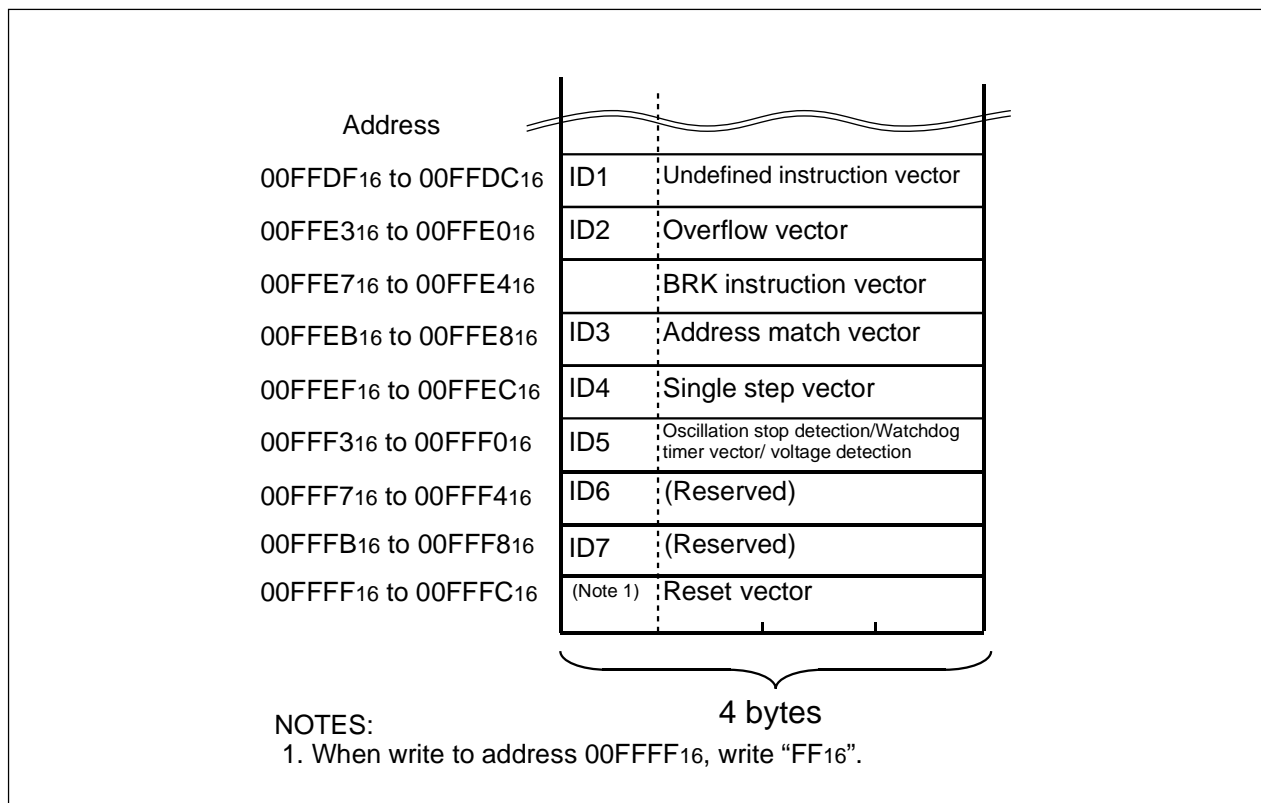

Figure 17.2 Address for ID Code Stored

## 17.4 CPU Rewrite Mode

In CPU rewrite mode, the user ROM area can be rewritten by executing software commands from the CPU. Therefore, the user ROM area can be rewritten directly while the microcomputer is mounted on-board without having to use a ROM programmer, etc. Make sure the Program and the Block Erase commands are executed only on each block in the user ROM area.

For interrupts requested during an erase operation in CPU rewrite mode, the R8C/11 flash module offers an "erase-suspend" feature which allow the erase operation to be suspended, and access made available to the flash.

During CPU rewrite mode, the user ROM area be operated on in either Erase Write 0 (EW0) mode or Erase Write 1 (EW1) mode. Table 17.3 lists the differences between Erase Write 0 (EW0) and Erase Write 1 (EW1) modes.

Table 17.3 EW0 Mode and EW1 Mode

Item	EW0 mode	EW1 mode
Operation mode	Single chip mode	Single chip mode
Areas in which a rewrite control program can be located	User ROM area	User ROM area
Areas in which a rewrite control program can be executed	Must be transferred to any area other than the flash memory (e.g., RAM) before being executed	Can be executed directly in the user ROM area
Areas which can be rewritten	User ROM area	User ROM area However, this does not include the block in which a rewrite control program exists <sup>(1)</sup>
Software command limitations	None	<ul style="list-style-type: none"> <li>• Program, Block Erase command Cannot be executed on any block in which a rewrite control program exists</li> <li>• Read Status Register command Cannot be executed</li> </ul>
Modes after Program or Erase	Read Status Register mode	Read Array mode
CPU status during Auto Write and Auto Erase	Operating	Hold state (I/O ports retain the state in which they were before the command was executed)
Flash memory status detection	<ul style="list-style-type: none"> <li>• Read the FMR0 register FMR00, FMR06, and FMR07 bits in a program</li> <li>• Execute the Read Status Register command to read the status register SR7, SR5, and SR4.</li> </ul>	Read the FMR0 register FMR00, FMR06, and FMR07 bits in a program
Conditions for transferring to erase-suspend	Set the FMR40 and FMR41 bits in the FMR4 register to "1" by program.	When an interrupt which is set for enabled occurs while the FMR40 bit in the FMR4 register is set to "1".

### NOTES:

1. Block 1 and Block 0 are enabled for rewrite by setting the FMR02 bit in the FMR0 register to "1" (rewrite enabled).

### 17.4.1 EW0 Mode

The microcomputer is placed in CPU rewrite mode by setting the FMR01 bit in the FMR0 register to "1" (CPU rewrite mode enabled), ready to accept commands. In this case, because the FMR1 register's FMR11 bit = 0, EW0 mode is selected.

Use software commands to control program and erase operations. Read the FMR0 register or status register to check the status of program or erase operation at completion.

When moving to an erase-suspend during auto-erase, set the FMR40 bit to "1" (erase-suspend enabled) and the FMR41 bit to "1" (erase-suspend requested). Wait for  $td(SR-ES)$  and make sure that the FMR46 bit is set to "1" (enables reading) before accessing the user ROM space. The auto-erase operation resumes by setting the FMR41 bit to "0" (erase restart).

### 17.4.2 EW1 Mode

EW1 mode is selected by setting FMR11 bit to "1" (EW1 mode) after setting the FMR01 bit to "1" (CPU rewrite mode enabled).

Read the FMR0 register to check the status of program or erase operation at completion. Avoid executing software commands of Read Status register in EW1 mode.

To enable the erase-suspend function, the Block Erase command should be executed after setting the FMR40 bit to "1" (erase-suspend enabled). An interrupt to request an erase-suspend must be in enabled state. After passing  $td(SR-ES)$  since the block erase command is executed, an interrupt request can be acknowledged.

When an interrupt request is generated, FMR41 bit is automatically set to "1" (erase-suspend requested) and the auto-erase operation is halted. If the auto-erase operation is not completed (FMR00 bit is "0") when the interrupt routine is ended, the Block Erase command should be executed again by setting the FMR41 bit to "0" (erase restart).

Figure 17.3 shows the FMR0 register. Figure 17.4 shows the FMR1 and FMR4 registers.

- **FMR00 Bit**

This bit indicates the operating status of the flash memory. The bit is “0” during programming, erasing, or erase-suspend mode; otherwise, the bit is “1”.

- **FMR01 Bit**

The microcomputer is made ready to accept commands by setting the FMR01 bit to “1” (CPU rewrite mode).

- **FMR02 Bit**

The Block1 and Block0 do not accept the Program and Block Erase commands if the FMR02 bit is set to “0” (rewrite disabled).

- **FMSTP Bit**

This bit is provided for initializing the flash memory control circuits, as well as for reducing the amount of current consumed in the flash memory. The flash memory is disabled against access by setting the FMSTP bit to “1”. Therefore, the FMSTP bit must be written to by a program in other than the flash memory.

In the following cases, set the FMSTP bit to “1”:

- When flash memory access resulted in an error while erasing or programming in EW0 mode (FMR00 bit not reset to “1” (ready))
- When entering on-chip oscillator mode (main clock stop)

Figure 17.6 shows a flow chart to be followed before and after entering on-chip oscillator mode (main clock stop).

Note that when going to stop or wait mode while the CPU rewrite mode is disabled, the FMR0 register does not need to be set because the power for the flash memory is automatically turned off and is turned back on again after returning from stop or wait mode.

- **FMR06 Bit**

This is a read-only bit indicating the status of auto program operation. The bit is set to “1” when a program error occurs; otherwise, it is cleared to “0”. For details, refer to the description of “17.4.5 full status check”.

- **FMR07 Bit**

This is a read-only bit indicating the status of auto erase operation. The bit is set to “1” when an erase error occurs; otherwise, it is set to “0”. For details, refer to the description of “17.4.5 full status check”.

- **FMR11 Bit**

Setting this bit to “1” (EW1 mode) places the microcomputer in EW1 mode.

- **FMR40 bit**

The erase-suspend function is enabled by setting the FMR40 bit to “1” (valid).

- **FMR41 bit**

In EW0 mode, the flash module goes to erase-suspend mode when the FMR41 bit is set to “1”. In EW1 mode, the FMR41 bit is automatically set to “1” (erase-suspend requested) when an enabled interrupt occurred, and then the flash module goes to erase-suspend mode.

The auto-erase operation restarts when the FMR41 bit is set to “0” (erase restart).

- **FMR46 bit**

The FMR46 bit is set to “0”(disables reading) during auto-erase execution and set to “1”(enables reading) during erase-suspend mode. Do not access to the flash memory when this bit is set to “0”.

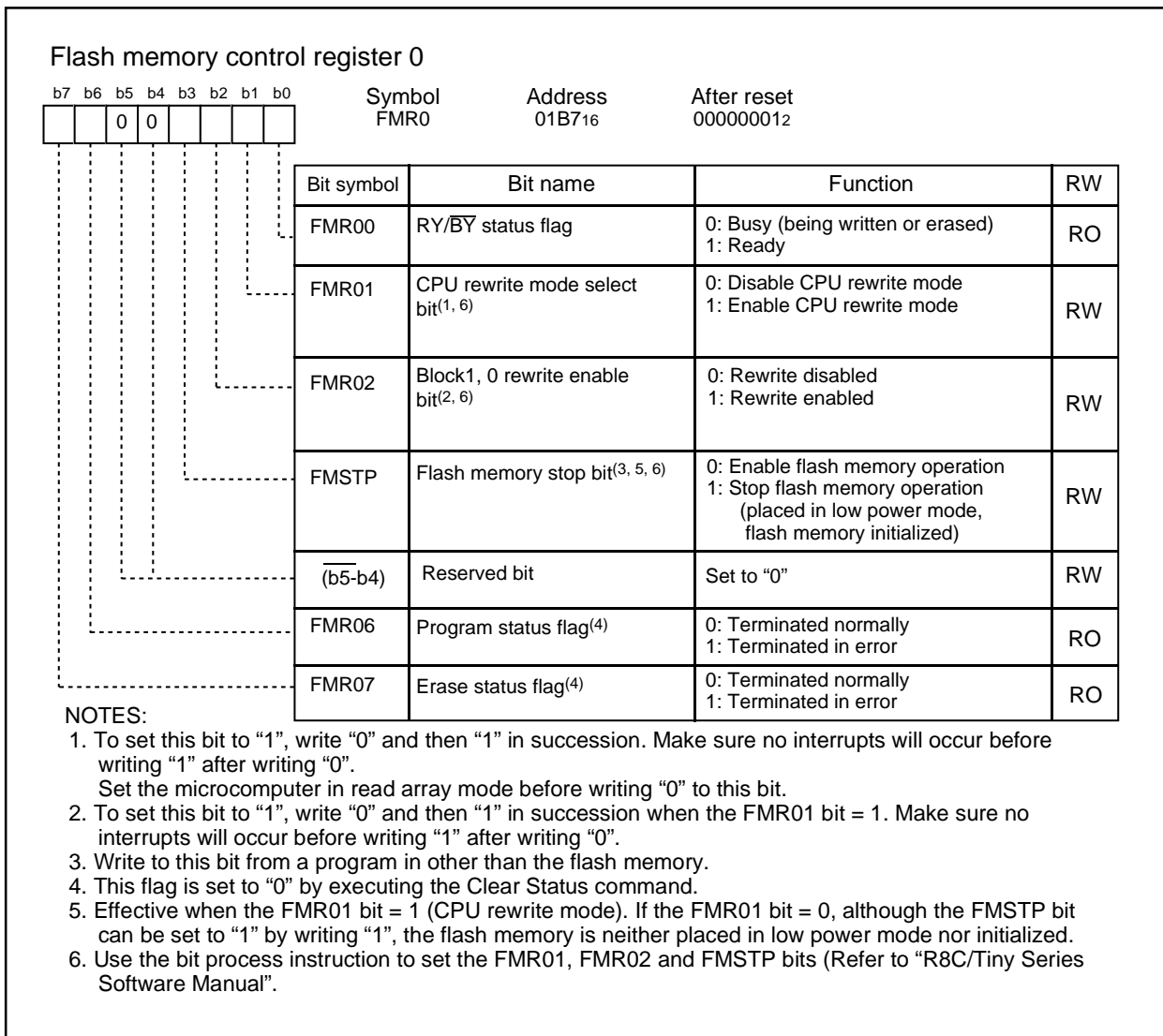

Figure 17.3 FMR0 Register

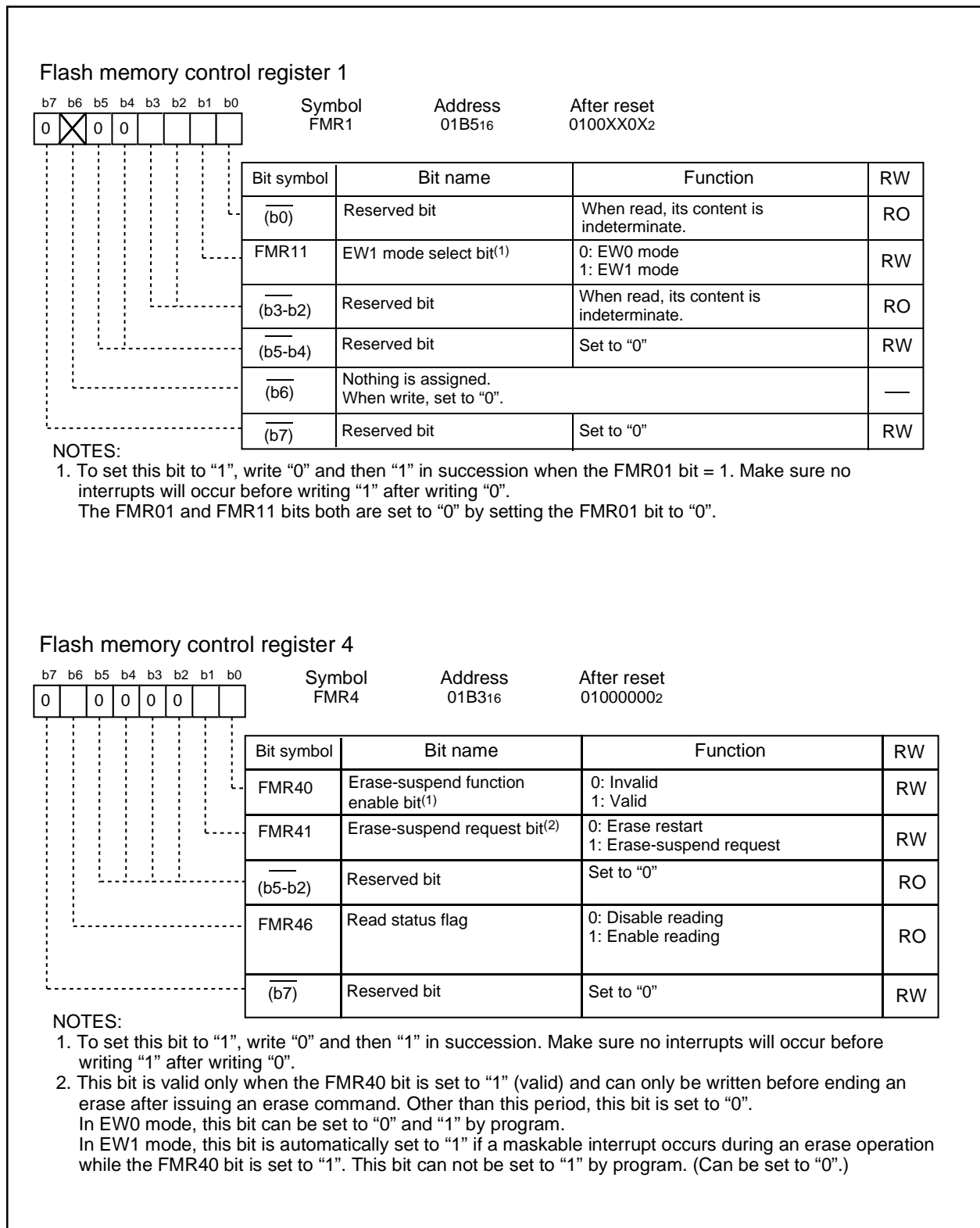

Figure 17.4 FMR1 Register and FMR4 Register

Figure 17.5 shows the timing on suspend operation.

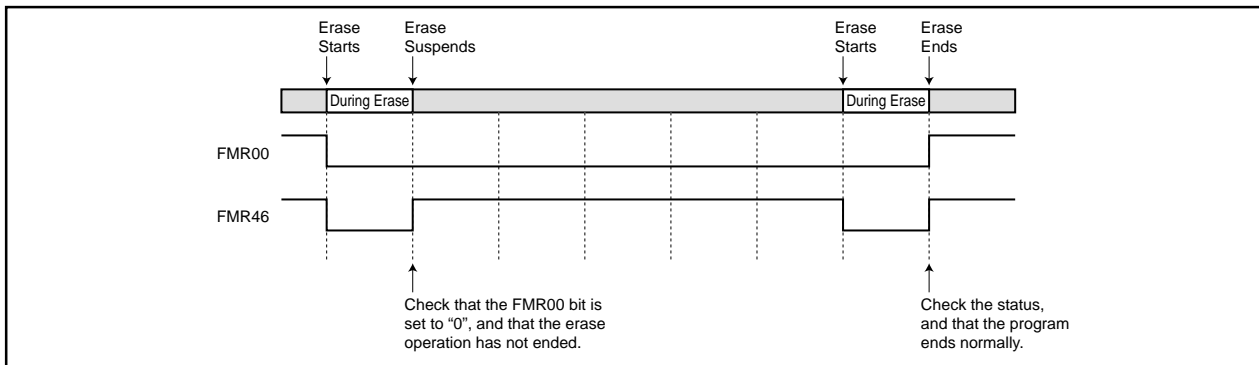

Figure 17.5 Timing on Suspend Operation

Figures 17.6 and 17.7 show the setting and resetting of EW0 mode and EW1 mode, respectively.

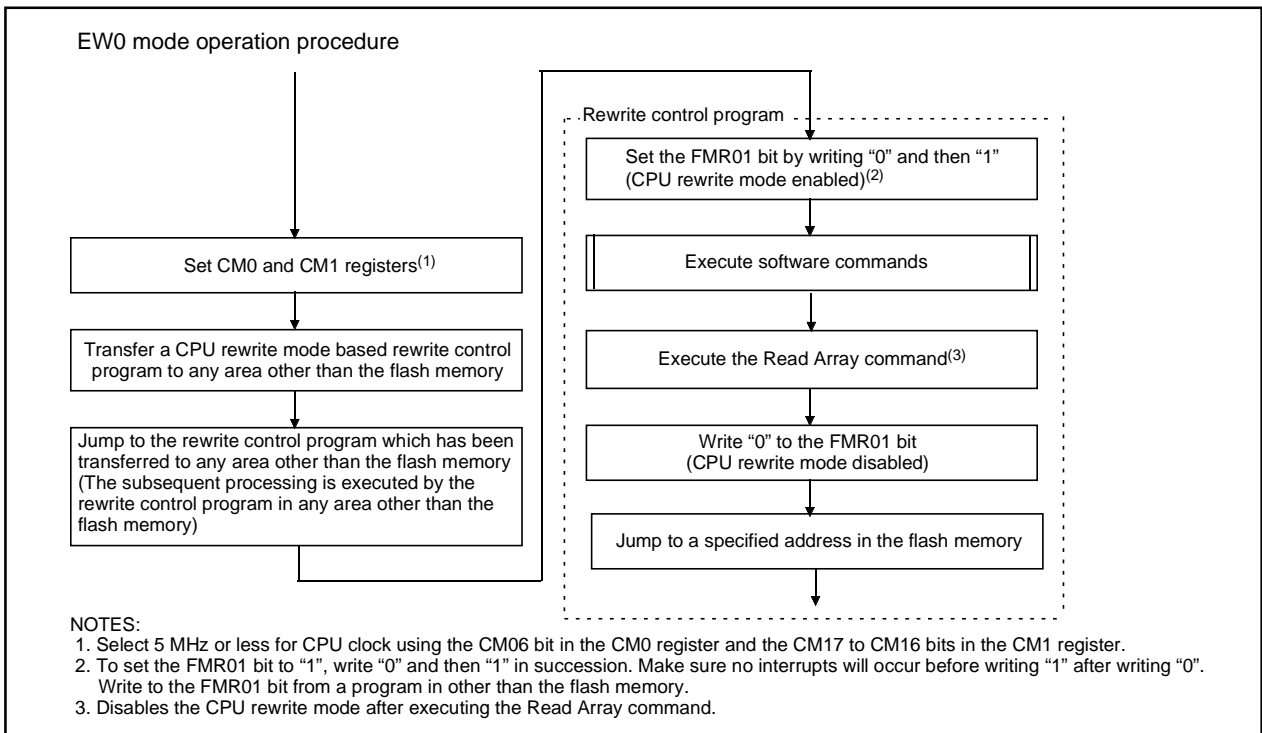

Figure 17.6 Setting and Resetting of EW0 Mode

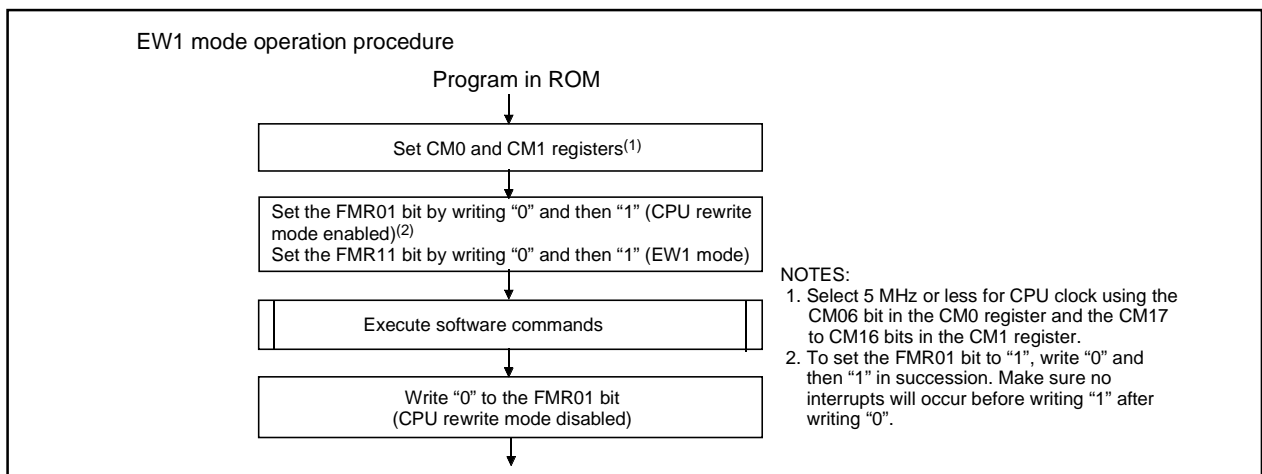
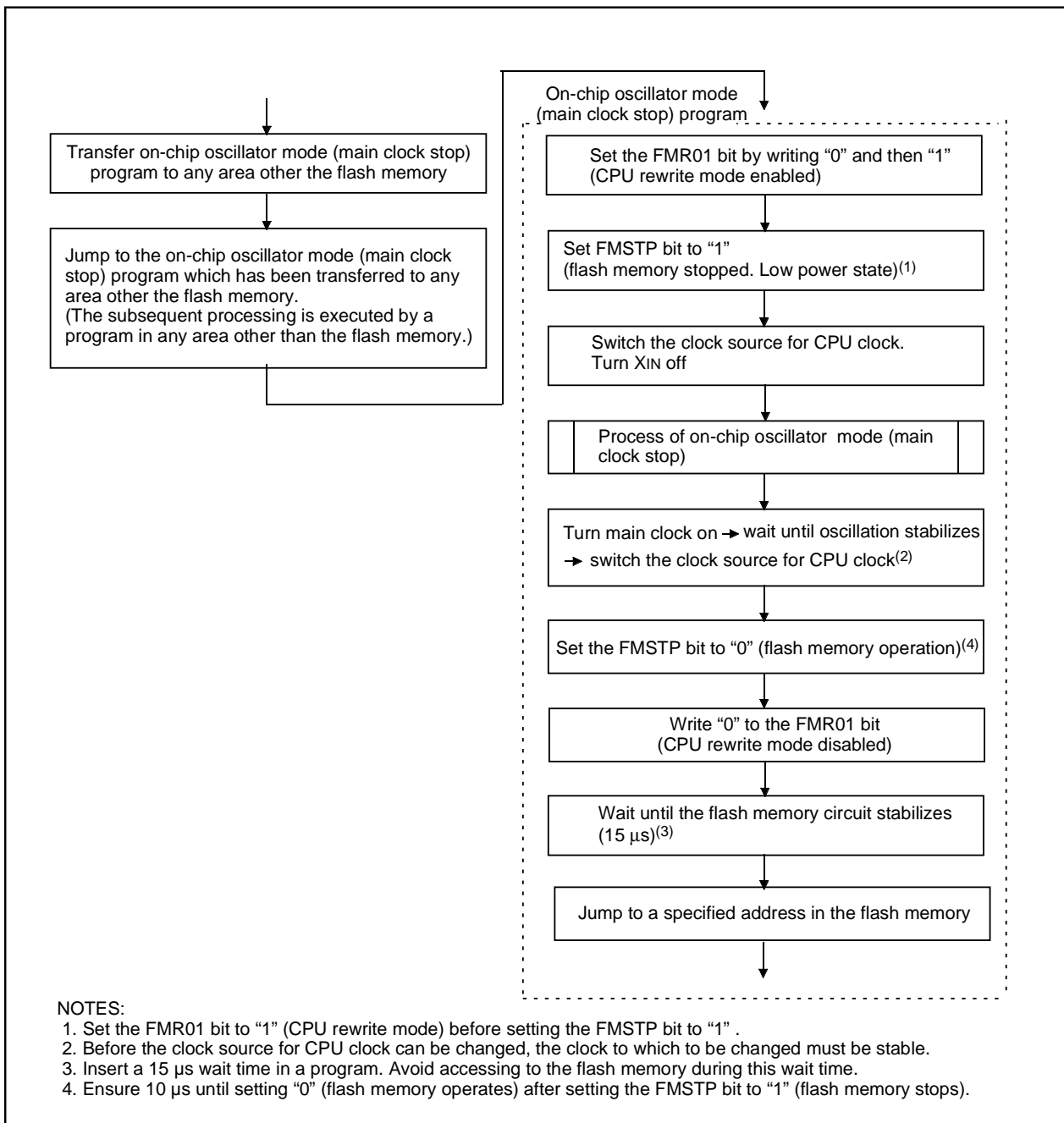

Figure 17.7 Setting and Resetting of EW1 Mode



**Figure 17.8 Process to Reduce Power Consumption in On-Chip Oscillator Mode (Main Clock Stop)**



### 17.4.3 Software Commands

Software commands are described below. The command code and data must be read and written in 8-bit units.

**Table 17.4 Software Commands**

Command	First bus cycle			Second bus cycle		
	Mode	Address	Data (D7 to D0)	Mode	Address	Data (D7 to D0)
Read array	Write	X	FF <sub>16</sub>			
Read status register	Write	X	70 <sub>16</sub>	Read	X	SRD
Clear status register	Write	X	50 <sub>16</sub>			
Program	Write	WA	40 <sub>16</sub>	Write	WA	WD
Block erase	Write	X	20 <sub>16</sub>	Write	BA	D0 <sub>16</sub>

SRD: Status register data (D7 to D0)

WA: Write address (Make sure the address value specified in the the first bus cycle is the same address as the write address specified in the second bus cycle.)

WD: Write data (8 bits)

BA: Given block address

X: Any address in the user ROM area

- **Read Array Command**

This command reads the flash memory.

Writing 'FF<sub>16</sub>' in the first bus cycle places the microcomputer in read array mode. Enter the read address in the next or subsequent bus cycles, and the content of the specified address can be read in 8-bit units.

Because the microcomputer remains in read array mode until another command is written, the contents of multiple addresses can be read in succession.

- **Read Status Register Command**

This command reads the status register.

Write '70<sub>16</sub>' in the first bus cycle, and the status register can be read in the second bus cycle. (Refer to Section 17.4.4, "Status Register.") When reading the status register too, specify an address in the user ROM area.

Avoid executing this command in EW1 mode.

- **Clear Status Register Command**

This command sets the status register to "0".

Write '50<sub>16</sub>' in the first bus cycle, and the FMR06 to FMR07 bits in the FMR0 register and SR4 to SR5 in the status register will be set to "0".

### • Program Command

This command writes data to the flash memory in one byte units.

Write '4016' in the first bus cycle and write data to the write address in the second bus cycle, and an auto program operation (data program and verify) will start. Make sure the address value specified in the first bus cycle is the same address as the write address specified in the second bus cycle.

Check the FMR00 bit in the FMR0 register to see if auto programming has finished. The FMR00 bit is "0" during auto programming and set to "1" when auto programming is completed.

Check the FMR06 bit in the FMR0 register after auto programming has finished, and the result of auto programming can be known. (Refer to Section 17.4.5, "Full Status Check.")

Writing over already programmed addresses is inhibited.

When the FMR02 bit in the FMR0 register is set to "0" (rewrite disabled), the Program command on the Block0 and Block1 is not accepted.

In EW1 mode, do not execute this command on any address at which the rewrite control program is located.

In EW0 mode, the microcomputer goes to read status register mode at the same time auto programming starts, making it possible to read the status register. The status register bit 7 (SR7) is set to "0" at the same time auto programming starts, and set back to "1" when auto programming finishes. In this case, the microcomputer remains in read status register mode until a read array command is written next. The result of auto programming can be known by reading the status register after auto programming has finished.

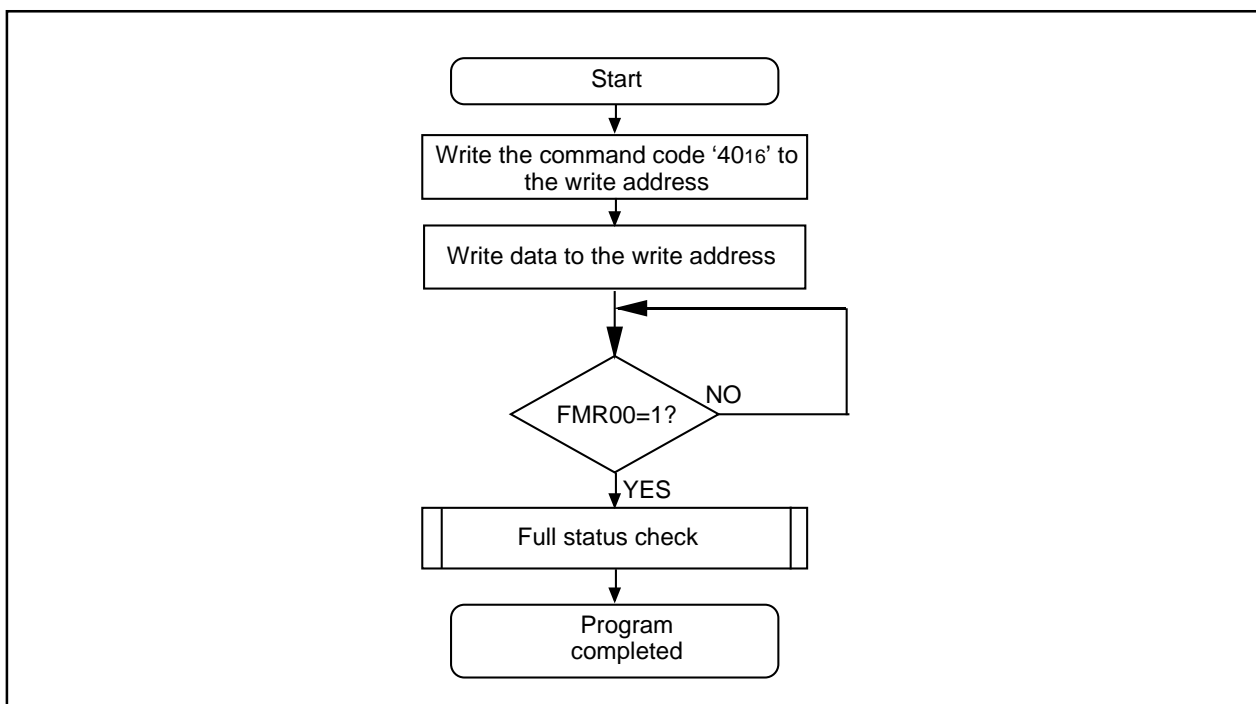

Figure 17.9 Program Command

### • Block Erase

Write '2016' in the first bus cycle and write 'D016' to the given address of a block in the second bus cycle, and an auto erase operation (erase and verify) will start.

Check the FMR00 bit in the FMR0 register to see if auto erasing has finished.

The FMR00 bit is "0" during auto erasing and set to "1" when auto erasing is completed.

Check the FMR07 bit in the FMR0 register after auto erasing has finished, and the result of auto erasing can be known. (Refer to Section 17.4.5, "Full Status Check.")

When the FMR02 bit in the FMR0 register is set to "0" (rewrite disabled), the Block Erase command on the Block0 and Block1 is not accepted.

Figure 17.10 shows an example of a block erase flowchart when the erase-suspend function is not used. Figure 17.11 shows an example of a block erase flowchart when the erase-suspend function is used.

In EW1 mode, do not execute this command on any address at which the rewrite control program is located.

In EW0 mode, the microcomputer goes to read status register mode at the same time auto erasing starts, making it possible to read the status register. The status register bit 7 (SR7) is cleared to "0" at the same time auto erasing starts, and set back to "1" when auto erasing finishes. In this case, the microcomputer remains in read status register mode until the Read Array command is written next.

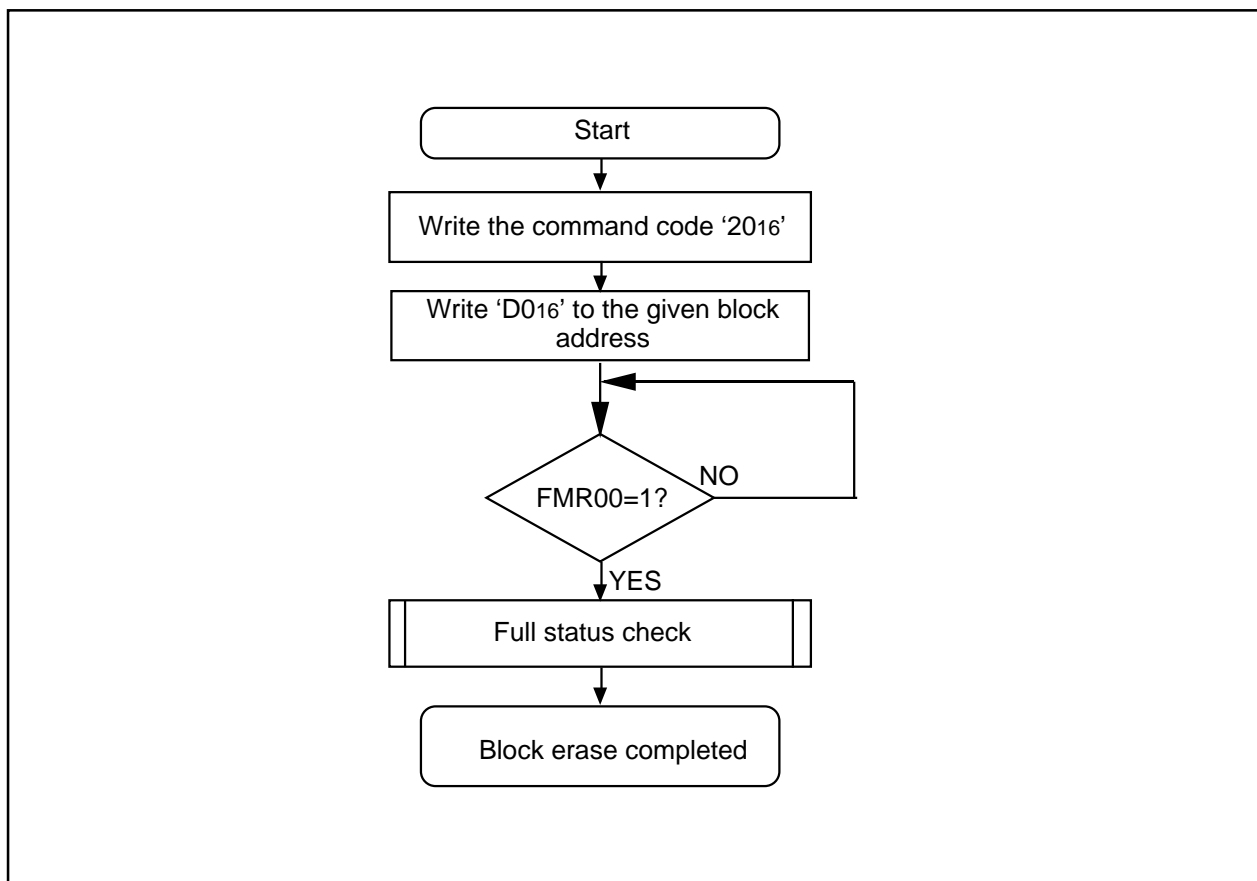

Figure 17.10 Block Erase Command (When Not Using Erase-suspend Function)

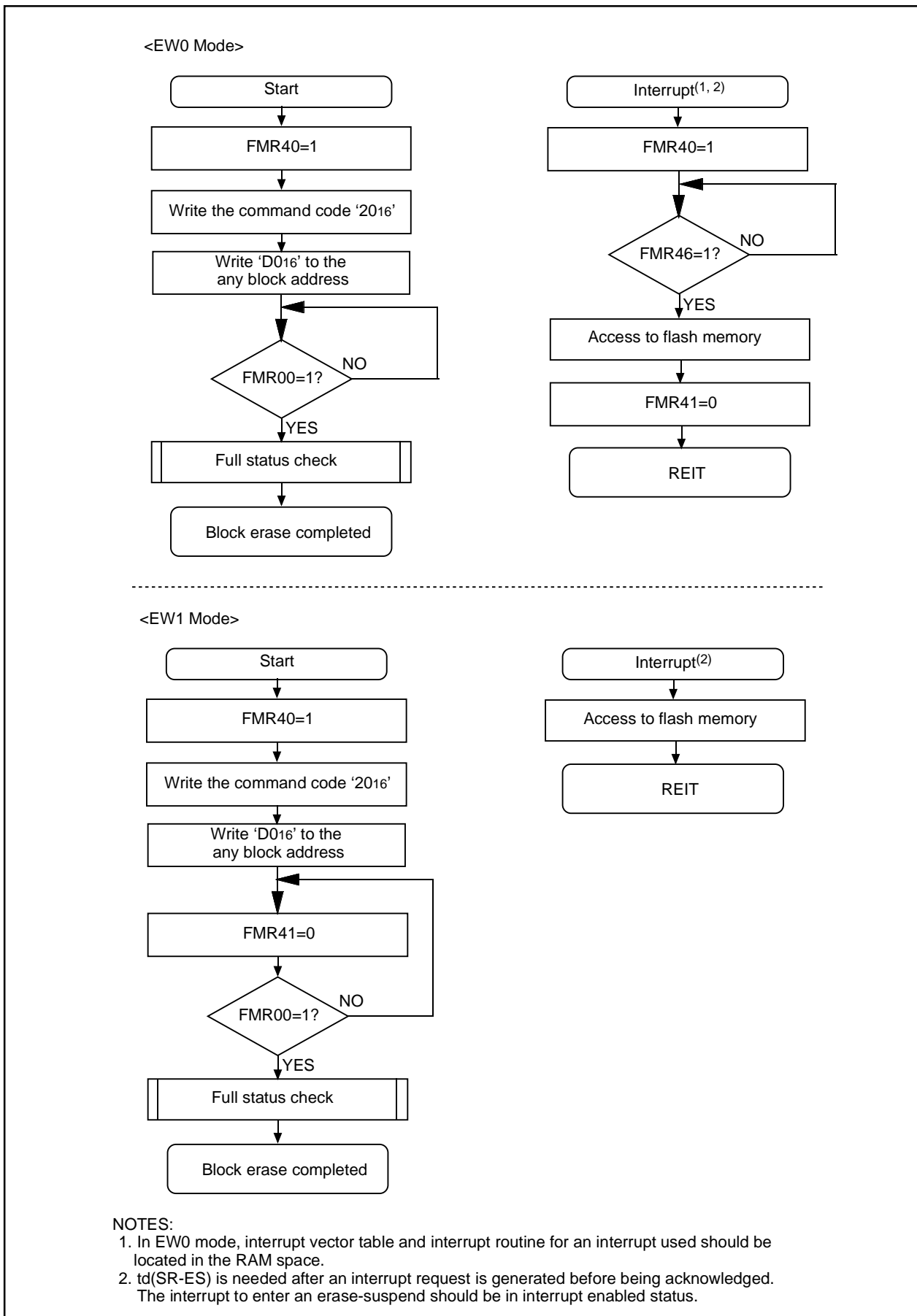

Figure 17.11 Block Erase Flow Chart (When Using Erase-suspend Function)

### 17.4.4 Status Register

The status register indicates the operating status of the flash memory and whether an erase or programming operation terminated normally or in error. The status of the status register can be known by reading the FMR00, FMR06, and FMR07 bits in the FMR0 register.

Table 17.5 lists the status register.

In EW0 mode, the status register can be read in the following cases:

- (1) When a given address in the user ROM area is read after writing the Read Status Register command
- (2) When a given address in the user ROM area is read after executing the Program or Block Erase command but before executing the Read Array command.

- **Sequence Status (SR7 and FMR00 Bits )**

The sequence status indicates the operating status of the flash memory. SR7 = 0 (busy) during auto programming and auto erase, and is set to "1" (ready) at the same time the operation finishes.

- **Erase Status (SR5 and FMR07 Bits)**

Refer to Section 17.4.5, "Full Status Check."

- **Program Status (SR4 and FMR06 Bits)**

Refer to Section 17.4.5, "Full Status Check."

**Table 17.5 Status Register**

Status register bit	FMR0 register bit	Status name	Contents		Value after reset
			"0"	"1"	
SR7 (D7)	FMR00	Sequencer status	Busy	Ready	1
SR6 (D6)	—	Reserved	-	-	—
SR5 (D5)	FMR07	Erase status	Terminated normally	Terminated in error	0
SR4 (D4)	FMR06	Program status	Terminated normally	Terminated in error	0
SR3 (D3)	—	Reserved	-	-	—
SR2 (D2)	—	Reserved	-	-	—
SR1 (D1)	—	Reserved	-	-	—
SR0 (D0)	—	Reserved	-	-	—

- D7 to D0: Indicates the data bus which is read out when the Read Status Register command is executed.
- The FMR07 bit (SR5) and FMR06 bit (SR4) are set to "0" by executing the Clear Status Register command.
- When the FMR07 bit (SR5) or FMR06 bit (SR4) = 1, the Program and Block Erase commands are not accepted.

### 17.4.5 Full Status Check

When an error occurs, the FMR06 to FMR07 bits in the FMR0 register are set to “1”, indicating occurrence of each specific error. Therefore, execution results can be verified by checking these status bits (full status check). Table 17.6 lists errors and FMR0 register status. Figure 17.12 shows a full status check flowchart and the action to be taken when each error occurs.

**Table 17.6 Errors and FMR0 Register Status**

FRM00 register (status register) status		Error	Error occurrence condition
FMR07 (SR5)	FMR06 (SR4)		
1	1	Command sequence error	<ul style="list-style-type: none"> <li>• When any command is not written correctly</li> <li>• When invalid data was written other than those that can be written in the second bus cycle of the Block Erase command (i.e., other than 'D016' or 'FF16')<sup>(1)</sup></li> <li>• When executing the program command or block erase command while rewriting is disabled using the FMR02 bit in the FMR0 register, the FMR15 or FMR16 bit in the FMR1 register.</li> <li>• When inputting and erasing the address in which the Flash memory is not allocated during the erase command input.</li> <li>• When executing to erase the block which disables rewriting during the erase command input.</li> <li>• When inputting and writing the address in which the Flash memory is not allocated during the write command input.</li> <li>• When executing to write the block which disables rewriting during the write command input.</li> </ul>
1	0	Erase error	<ul style="list-style-type: none"> <li>• When the Block Erase command was executed but not automatically erased correctly</li> </ul>
0	1	Program error	<ul style="list-style-type: none"> <li>• When the Program command was executed but not automatically programmed correctly.</li> </ul>

**NOTES:**

1. Writing 'FF16' in the second bus cycle of these commands places the microcomputer in read array mode, and the command code written in the first bus cycle is nullified.

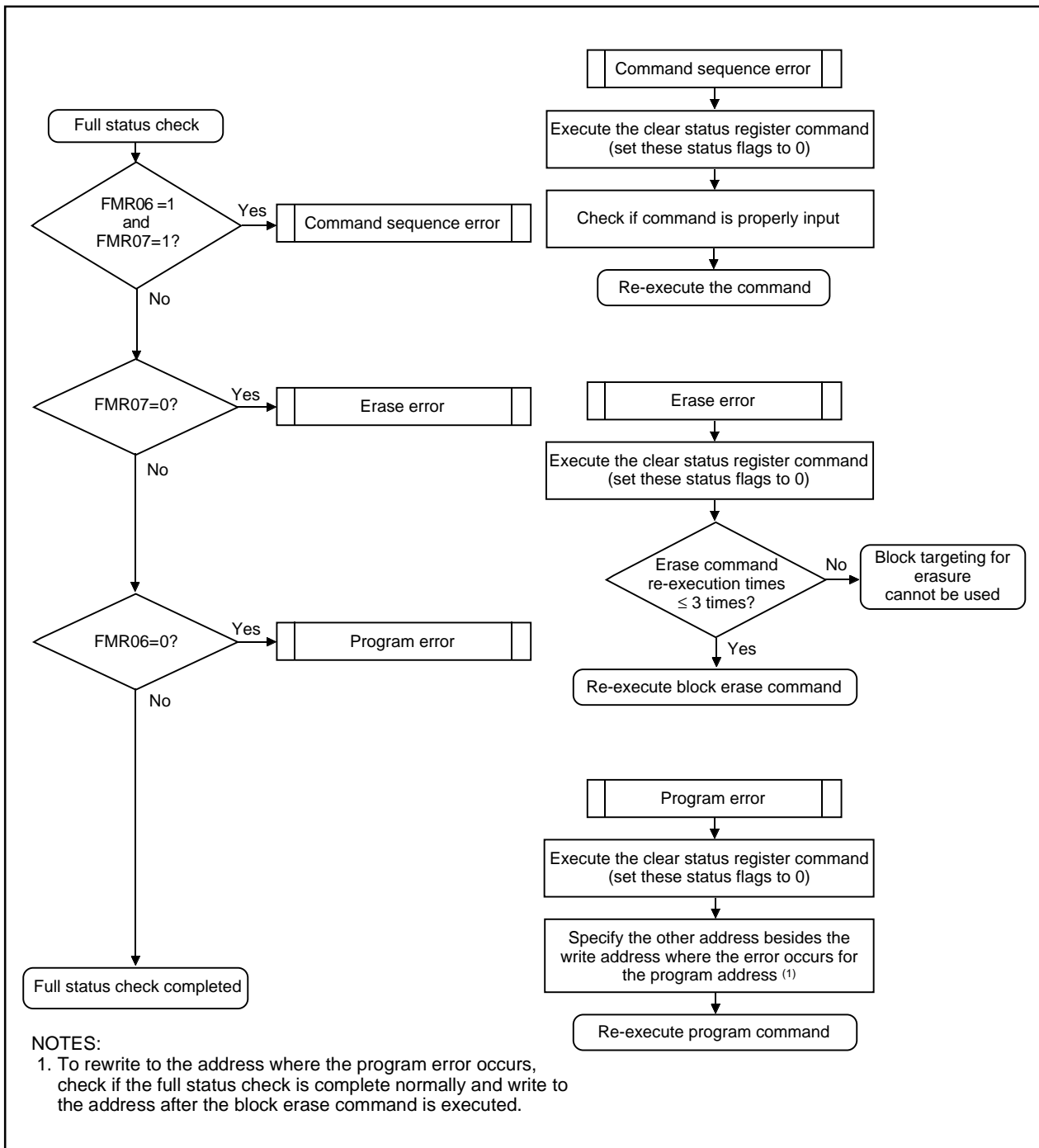

Figure 17.12 Full Status Check and Handling Procedure for Each Error

## 17.5 Standard Serial I/O Mode

In standard serial I/O mode, the user ROM area can be rewritten while the microcomputer is mounted on-board by using a serial programmer suitable for this microcomputer. Standard serial I/O mode has standard serial I/O mode 1 of the clock synchronous serial and standard serial I/O mode 2 of the clock asynchronous serial. Refer to "Appendix 2 Connecting Examples for Serial Writer and On-chip Debugging Emulator". For more information about serial programmers, contact the manufacturer of your serial programmer. For details on how to use, refer to the user's manual included with your serial programmer. Table 17.7 lists pin functions (flash memory standard serial input/output mode). Figures 17.13 to 17.15 show pin connections for standard serial I/O mode.

### 17.5.1 ID Code Check Function

This function determines whether the ID codes sent from the serial programmer and those written in the flash memory match (refer to Section 17.3, "Functions to Prevent Flash Memory from Rewriting").



**Table 17.7 Pin Functions (Flash Memory Standard Serial I/O Mode)**

Pin	Name	I/O	Description
Vcc,Vss	Power input		Apply the voltage guaranteed for Program and Erase to Vcc pin and 0V to Vss pin.
IVcc	IVcc		Connect capacitor (0.1 $\mu$ F) to Vss.
RESET	Reset input	I	Reset input pin.
P46/XIN	P46 input/Clock input	I	Connect a ceramic resonator or crystal oscillator between XIN and XOUT pins in standard serial I/O mode 2. When using the main clock in standard serial I/O mode 1, connect a ceramic resonator or crystal oscillator between XIN and XOUT pins. When not using the main clock in standard serial I/O mode 1, connect this pin to Vcc via a resistor(pull-up)
P47/XOUT	P47 input/Clock output	I/O	
AVcc, AVss	Analog power supply input	I	Connect AVss to Vss and AVcc to Vcc, respectively.
VREF	Reference voltage input	I	Enter the reference voltage for AD from this pin.
P01 to P07	Input port P0	I	Input "H" or "L" level signal or open.
P10 to P17	Input port P1	I	Input "H" or "L" level signal or open.
P30 to P33	Input port P3	I	Input "H" or "L" level signal or open.
P45	Input port P4	I	Input "H" or "L" level signal or open.
P00	TxD output	O	Serial data output pin
MODE	MODE	I/O	Standard serial I/O mode 1: connect to flash programmer Standard serial I/O mode 2: Input "L".
CNVss	CNVss	I/O	Standard serial I/O mode 1: connect to flash programmer Standard serial I/O mode 2: Input "L".
P37	RxD input	I	Serial data input pin

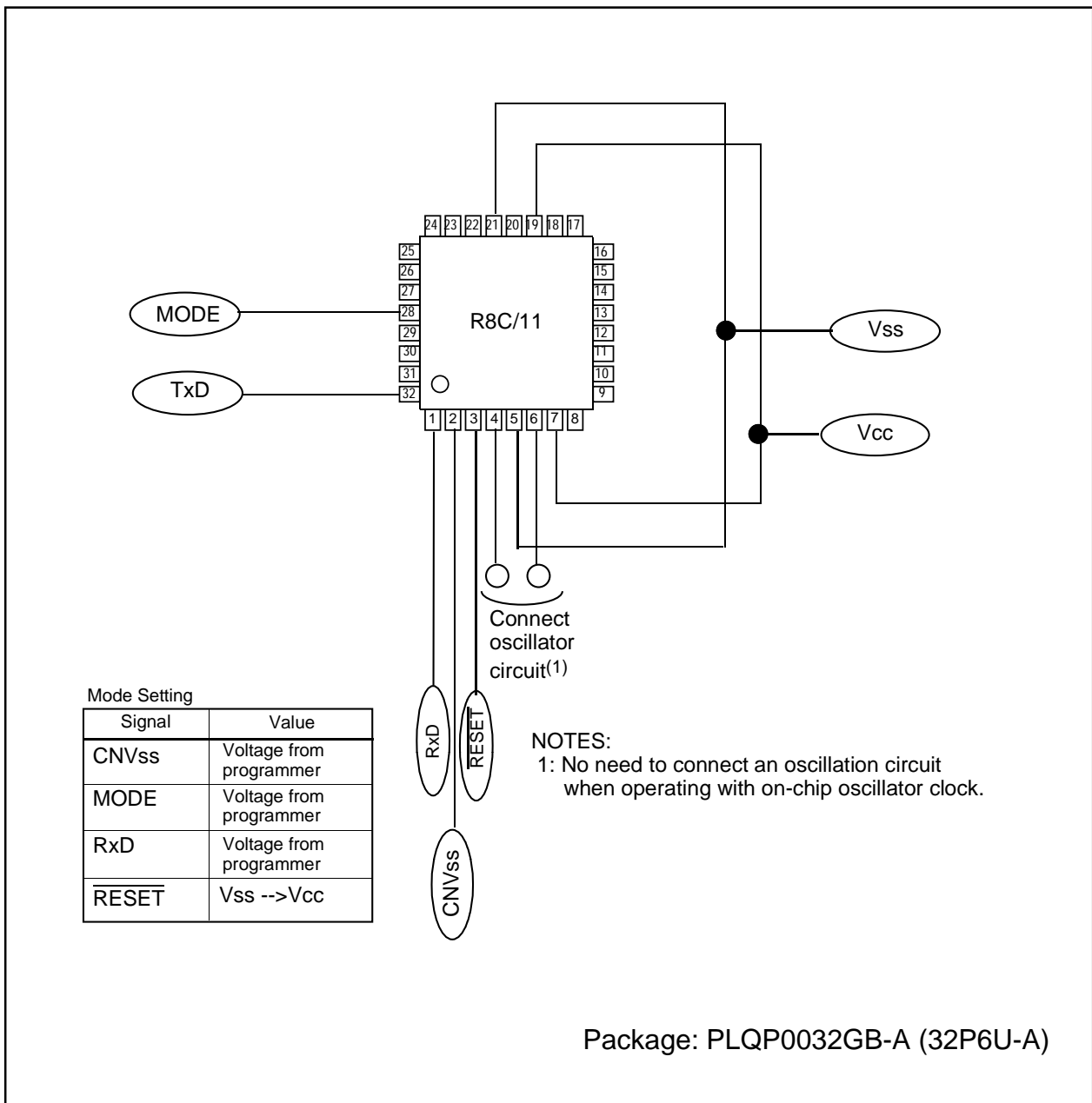
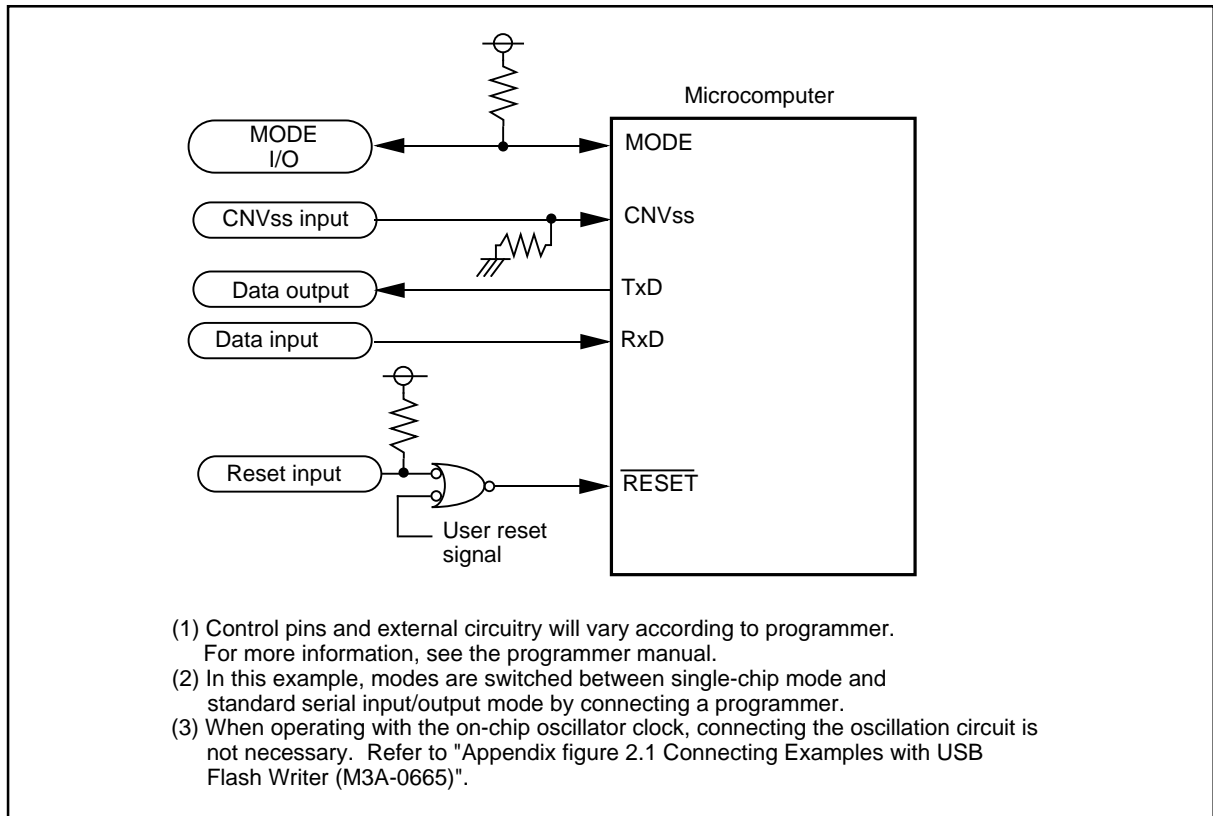

Figure 17.13 Pin Connections for Standard Serial I/O Mode

### • Example of Circuit Application in the Standard Serial I/O Mode

Figures 17.14 and 17.15 show examples of circuit application in standard serial I/O mode 1 and mode 2, respectively. Refer to the serial programmer manual of your programmer to handle pins controlled by the programmer.



**Figure 17.14 Circuit Application in Standard Serial I/O Mode 1**

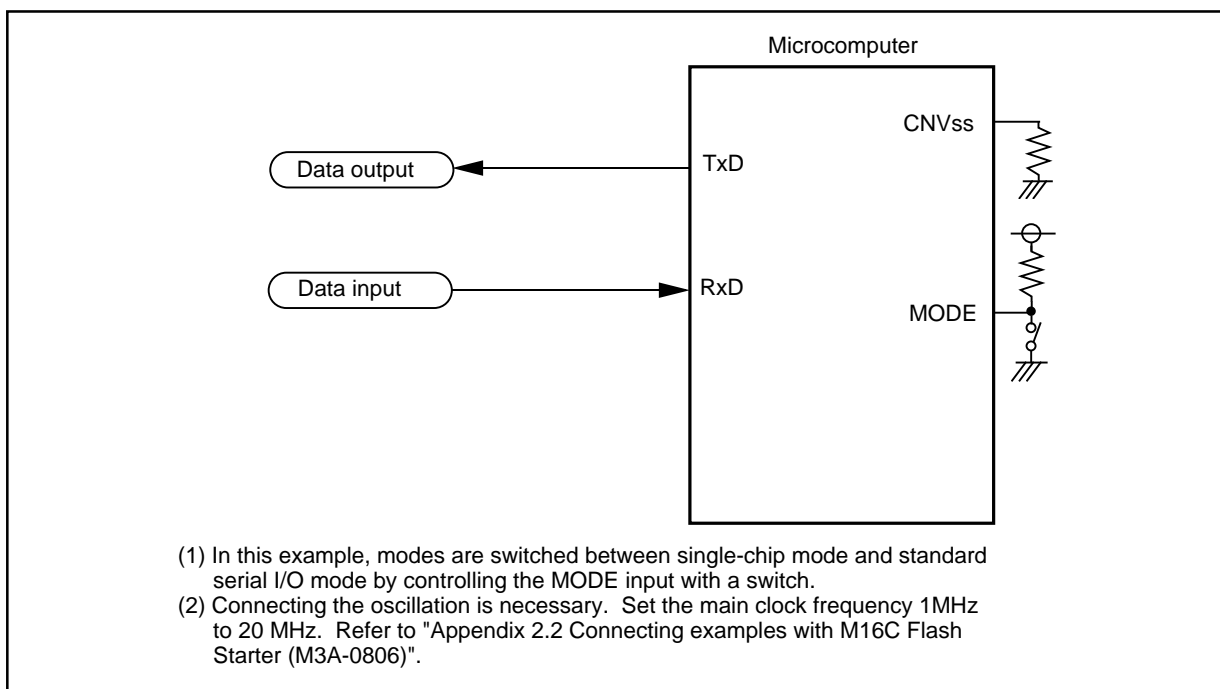

**Figure 17.15 Circuit Application in Standard Serial I/O Mode 2**

## 18. On-chip debugger

The microcomputer has functions to execute the on-chip debugger. Refer to "Appendix 2 Connecting examples for serial writer and on-chip debugging emulator". Refer to the respective on-chip debugger manual for the details of the on-chip debugger. Next, here are some explanations for the respective functions. Debugging the user system which uses these functions is not available. When using the on-chip debugger, design the system without using these functions in advance. Additionally, the on-chip debugger uses the address  $0C000_{16}$  to  $0C7FF_{16}$  of the flash memory, thus avoid using for the user system.

### 18.1 Address match interrupt

The interrupt request is generated right before the arbitrary address instruction is executed. The debugger break function uses the address match interrupt. Refer to "10.4 Address match interrupt" for the details of the address match interrupt. Also, avoid setting the address match interrupt (the registers of AIER, RMAD0, RMAD1 and the fixed vector tables) with using the user system when using the on-chip debugger.

### 18.2 Single step interrupt

The interrupt request is generated every time one instruction is executed. The debugger single step function uses the single step interrupt. The other interrupt is not generated when using the single step interrupt. The single step interrupt is only for the developed support tool.

### 18.3 UART1

The UART1 is used for the communication with the debugger (or the personal computer). Refer to "13. Serial Interface" for the details of UART1. Also, avoid using the UART1 and the functions (P0<sub>0</sub>/AN<sub>7</sub> and P3<sub>7</sub>) which share the UART1 pins.

### 18.4 BRK instruction

The BRK interrupt request is generated. Refer to "10.1 Interrupt overview" and "R8C/Tiny series software manual". Also, avoid using the BRK instruction with using the user system when using the on-chip debugger.

## 19. Usage Notes

### 19.1 Stop Mode and Wait Mode

#### 19.1.1 Stop Mode

When entering stop mode, set the CM10 bit to “1” (stop mode) after setting the FMR01 bit to “0” (CPU rewrite mode disabled). The instruction queue pre-reads 4 bytes from the instruction which sets the CM10 bit in the CM1 register to “1” (stop mode) and the program stops. Insert at least 4 NOP instructions after inserting the JMP.B instruction immediately after the instruction which sets the CM10 bit to “1”.

Use the next program to enter stop mode.

- Program of entering stop mode

```

        BCLR    1, FMR0    ; CPU rewrite mode disabled
        BSET    0, PRCR    ; Protect exited
        BSET    0, CM1    ; Stop mode
        JMP.B   LABEL_001
LABEL_001:
        NOP
        NOP
        NOP
        NOP

```

#### 19.1.2 Wait Mode

When entering wait mode, execute the WAIT instruction after setting the FMR01 bit to “0” (CPU rewrite mode disabled). The instruction queue pre-reads 4 bytes from the WAIT instruction and the program stops. Insert at least 4 NOP instructions after the WAIT instruction.

Also, the value in the specific internal RAM area may be rewritten when exiting wait mode if writing to the internal RAM area before executing the WAIT instruction and entering wait mode. The area for a maximum of 3 bytes is rewritten from the following address of the internal RAM in which the writing is performed before the WAIT instruction. If this causes a problem, avoid by inserting the JMP.B instruction between the writing instruction to the internal RAM area and WAIT instruction as shown in the following program example.

- Example to execute WAIT instruction

```

Program Example  MOV.B   #055h,0601h    ; Write to internal RAM area
                ...
                JMP.B   LABEL_001
LABEL_001 :
                FSET    I                ; Interrupt enabled
                BCLR    1,FMR0          ; CPU rewrite mode disabled
                WAIT                    ; Wait mode
                NOP
                NOP
                NOP
                NOP

```

When accessing any area other than the internal RAM area between the writing instruction to the internal RAM area and execution of the WAIT instruction, this situation will not occur.

## 19.2 Interrupt

### 19.2.1 Reading Address 00000<sub>16</sub>

Do not read the address 00000<sub>16</sub> by a program. When a maskable interrupt request is acknowledged, the CPU reads interrupt information (interrupt number and interrupt request level) from 00000<sub>16</sub> in the interrupt sequence. At this time, the acknowledged interrupt IR bit is set to "0".

If the address 00000<sub>16</sub> is read by a program, the IR bit for the interrupt which has the highest priority among the enabled interrupts is set to "0". This may cause a problem that the interrupt is canceled, or an unexpected interrupt is generated.

### 19.2.2 SP Setting

Set any value in the SP before an interrupt is acknowledged. The SP is set to "0000<sub>16</sub>" after reset. Therefore, if an interrupt is acknowledged before setting any value in the SP, the program may run out of control.

### 19.2.3 External Interrupt and Key Input Interrupt

Either an "L" level or an "H" level of at least 250ns width is necessary for the signal input to the  $\overline{\text{INT}}_0$  to  $\overline{\text{INT}}_3$  pins and  $\overline{\text{KI}}_0$  to  $\overline{\text{KI}}_3$  pins regardless of the CPU clock.

### 19.2.4 Watchdog Timer Interrupt

Reset the watchdog timer after a watchdog timer interrupt is generated.

### 19.2.5 Changing Interrupt Factor

The IR bit in the interrupt control register may be set to “1” (interrupt requested) when the interrupt factor is changed. When using an interrupt, set the IR bit to “0” (interrupt not request) after changing the interrupt factor. In addition, the changes of interrupt factors include all elements that change the interrupt factors assigned to individual software interrupt numbers, polarities, and timing. Therefore, when a mode change of the peripheral functions involves interrupt factors, edge polarities, and timing, set the IR bit to “0” (interrupt not requested) after the change. Refer to each peripheral function for the interrupts caused by the peripheral functions.

Figure 19.1 shows an Example of Procedure for Changing Interrupt Factor.

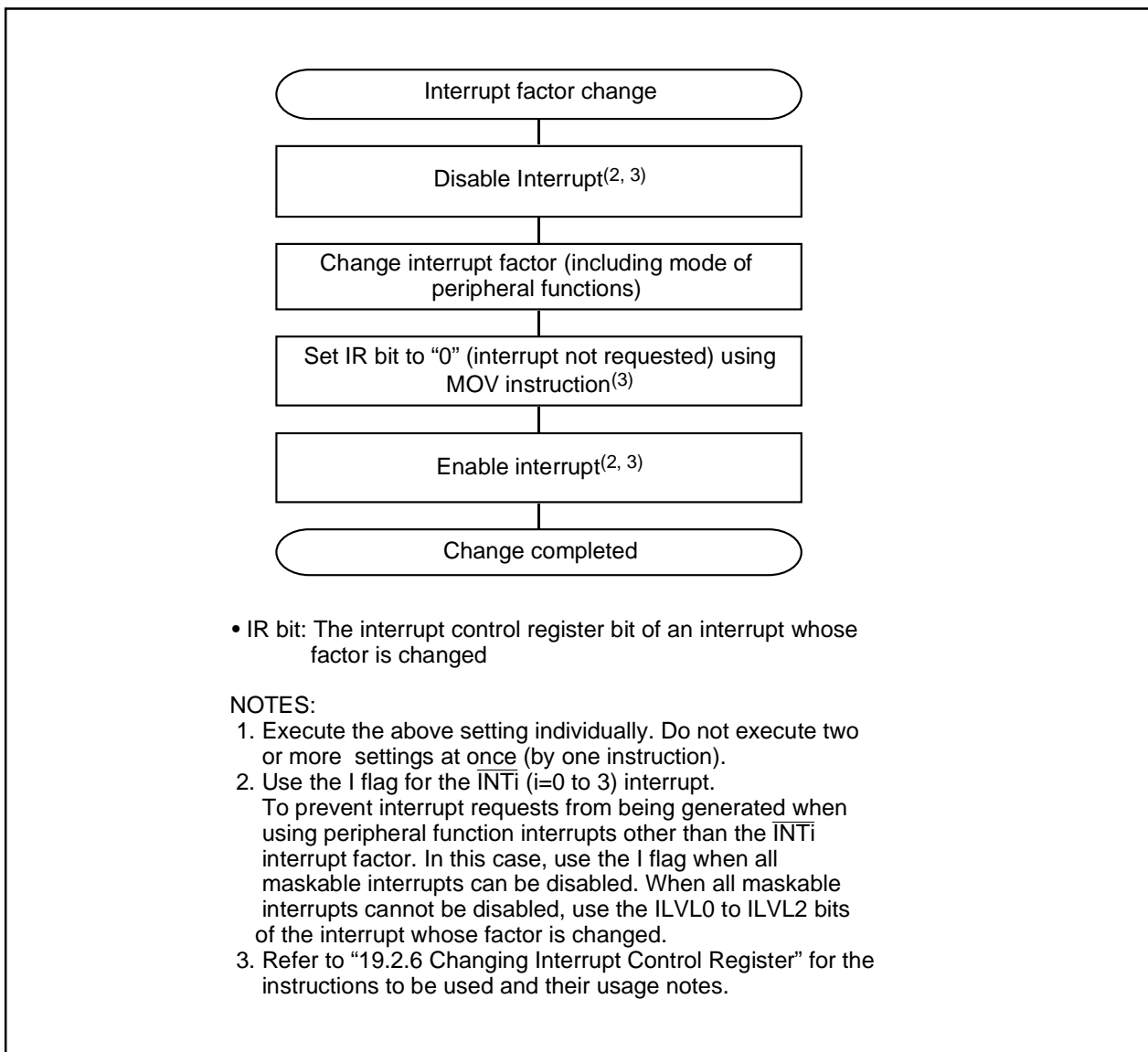

Figure 19.1 Example of Procedure for Changing Interrupt Factor

### 19.2.6 Changing Interrupt Control Register

(1) Each interrupt control register can only be changed while interrupt requests corresponding to that register are not generated. If interrupt requests may be generated, disable the interrupts before changing the interrupt control register.

(2) When changing any interrupt control register after disabling interrupts, be careful with the instruction to be used.

#### When Changing Any Bit Other Than IR Bit

If an interrupt request corresponding to that register is generated while executing the instruction, the IR bit may not be set to "1" (interrupt requested), and the interrupt request may be ignored. If this causes a problem, use the following instructions to change the register.

Instructions to use: AND, OR, BCLR, BSET

#### When Changing IR Bit

If the IR bit is set to "0" (interrupt not requested), it may not be set to "0" depending on the instruction used. Use the MOV instruction to set the IR bit to "0".

(3) When disabling interrupts using the I flag, set the I flag according to the following sample programs. Refer to (2) for the change of interrupt control registers in the sample programs.

Sample programs 1 to 3 are preventing the I flag from being set to "1" (interrupt enabled) before writing to the interrupt control registers for reasons of the internal bus or the instruction queue buffer.

#### Example 1: Use NOP instructions to prevent I flag being set to "1" before interrupt control register is changed

```
INT_SWITCH1:
  FCLR   I           ; Disable interrupts
  AND.B  #00H, 0056H ; Set TXIC register to "0016"
  NOP
  NOP
  FSET   I           ; Enable interrupts
```

#### Example 2: Use dummy read to have FSET instruction wait

```
INT_SWITCH2:
  FCLR   I           ; Disable interrupts
  AND.B  #00H, 0056H ; Set TXIC register to "0016"
  MOV.W  MEM, R0     ; Dummy read
  FSET   I           ; Enable interrupts
```

#### Example 3: Use POPC instruction to change I flag

```
INT_SWITCH3:
  PUSHC  FLG
  FCLR   I           ; Disable interrupts
  AND.B  #00H, 0056H ; Set TXIC register to "0016"
  POPC   FLG        ; Enable interrupts
```



## 19.3 Clock Generation Circuit

### 19.3.1 Oscillation Stop Detection Function

Since the oscillation stop detection function cannot be used if the main clock frequency is below 2MHz, set the OCD1 to OCD0 bits to "002" (oscillation stop detection function disabled).

### 19.3.2 Oscillation Circuit Constants

Ask the maker of the oscillator to specify the best oscillation circuit constants on your system.

## 19.4 Timers

### 19.4.1 Timers X, Y and Z

- (1) Timers X, Y and Z stop counting after reset. Therefore, a value must be set to these timers and prescalers before starting counting.
- (2) Even if the prescalers and timers are read out simultaneously in 16-bit units, these registers are read byte-by-byte in the microcomputer. Consequently, the timer value may be updated during the period these two registers are being read.

### 19.4.2 Timer X

- (1) Do not rewrite the TXMOD0 to TXMOD1 bits, the TXMOD2 bit and TXS bit simultaneously.
- (2) In pulse period measurement mode, the TXEDG bit and TXUND bit in the TXMR register can be set to "0" by writing "0" to these bits in a program. However, these bits remain unchanged when "1" is written. To set one flag to "0" in a program, write "1" to the other flag by using the MOV instruction. (This prevents any unintended changes of flag.)

Example (when setting TXEDG bit to "0"):

```
MOV.B    #10XXXXXXB,008BH
```

- (3) When changing to pulse period measurement mode from other mode, the contents of the TXEDG bit and TXUND bit are indeterminate. Write "0" to the TXEDG bit and TXUND bit before starting counting.
- (4) The prescaler X underflow which is generated for the first time after the count start may cause that the TXEDG bit is set to "1". When using the pulse period measurement mode, leave more than two periods of the prescaler X right after count starts and set the TXEDG bit to "0".

### 19.4.3 Timer Y

- (1) Do not rewrite the TYMOD0 and TYS bits simultaneously.

### 19.4.4 Timer Z

- (1) Do not rewrite the TZMOD0 to TZMOD1 bits and the TZS bit simultaneously.
- (2) In programmable one-shot generation mode and programmable wait one-shot generation mode, when setting the TZS bit in the TC register to "0" (stops counting) or setting the TZOS bit in the TZOC register to "0" (stops one-shot), the timer reloads the value of reload register and stops. Therefore, the timer count value should be read out in programmable one-shot generation mode and programmable wait one-shot generation mode before the timer stops.

### 19.4.5 Timer C

- (1) Access the TC, TM0 and TM1 registers in 16-bit units.  
This prevents the timer value from being updated between the low-order byte and high-order byte are being read.

Example (when Timer C is read):

```
MOV.W    0090H,R0 ; Read out timer C
```

## 19.5 Serial Interface

- (1) When reading data from the UiRB (i=0,1) register even in the clock asynchronous serial I/O mode or in the clock synchronous serial I/O mode. Be sure to read data in 16-bit unit. When the high-byte of the UiRB register is read, the PER and FER bits of the UiRB register and the RI bit of the UiC1 register are set to "0".

Example (when reading receive buffer register):

```
MOV.W    00A6H, R0    ; Read the UORB register
```

- (2) When writing data to the UiTB register in the clock asynchronous serial I/O mode with 9-bit transfer data length, data should be written high-byte first then low-byte in 8-bit unit.

Example (when reading transmit buffer register):

```
MOV.B    #XXH, 00A3H  ; Write the high-byte of U0TB register  
MOV.B    #XXH, 00A2H  ; Write the low-byte of U0TB register
```

## 19.6 A/D Converter

- (1) When writing to each bit but except bit 6 in the ADCON0 register, each bit in the ADCON1 register, or the SMP bit in the ADCON2 register, A/D conversion must be stopped (before a trigger occurs).  
When the VCUT bit in the ADCON1 register is changed from "0" (VREF not connected) to "1" (VREF connected), wait at least 1  $\mu$ s before starting A/D conversion.
- (2) When changing AD operation mode, select an analog input pin again.
- (3) In one-shot mode, A/D conversion must be completed before reading the AD register. The IR bit in the ADIC register or the ADST bit in the ADCON0 register can indicate whether the A/D conversion is completed or not.
- (4) In repeat mode, the undivided main clock must be used for the CPU clock.
- (5) If A/D conversion is forcibly terminated while in progress by setting the ADST bit in the ADCON0 register to "0" (A/D conversion halted), the conversion result of the A/D converter is indeterminate. If the ADST bit is set to "0" in a program, ignore the value of AD register.
- (6) A 0.1  $\mu$ F capacitor should be connected between the AVcc/VREF pin and AVss pin.

## 19.7 Flash Memory Version

### 19.7.1 CPU Rewrite Mode

- Operation Speed

Before entering CPU rewrite mode (EW0 mode, EW1 mode), select 5MHz or below for the CPU clock using the CM06 bit in the CM0 register and the CM16 to CM17 bits in the CM1 register.

- Instructions Disabled Against Use

The following instructions cannot be used in EW0 mode because the flash memory internal data is referenced: UND, INTO and BRK instructions.

- How to Access

Write "0" to the corresponding bits before writing "1" when setting the FMR01, FMR02, and FMR11 bits to "1". Do not generate an interrupt between writing "0" and "1".

- Rewriting User ROM Area

In EW0 mode, if the power supply voltage drops while rewriting any block in which the rewrite control program is stored, the flash memory may not be able to be rewritten because the rewrite control program cannot be rewritten correctly. In this case, use standard serial I/O mode.

- Reset Flash Memory

Since the CPU stops and cannot return when setting the FMSTP bit in the FMR0 register to "1" (flash memory stops) during erase suspend in EW1 mode, do not set the FMSTP bit to "1".

- Entering Stop Mode or Wait Mode

Do not enter stop mode or wait mode during erase-suspend.

● Interrupt

Table 19.1 list the Interrupt in EW0 Mode and Table 19.2 lists the Interrupt in EW1 Mode.

Table 19.1 Interrupt in EW0 Mode

Mode	Status	When maskable interrupt request is acknowledged	When watchdog timer, oscillation stop detection, and voltage detection interrupt request are acknowledged
EW0	During auto- matic erasing	Any interrupt can be used by allocating a vector to RAM	Once an interrupt request is acknowledged, the auto-programming or auto-erasing is forcibly stopped and resets the flash memory. An interrupt process starts after the fixed period and the flash memory restarts. Since the block during the auto-erasing or the address during the auto-programming is forcibly stopped, the normal value may not be read. Execute the auto-erasing again and ensure the auto-erasing is completed normally.  Since the watchdog timer does not stop during the command operation, the interrupt request may be generated. Reset the watchdog timer regularly.
	Automatic writing		

NOTES:

1. Do not use the address match interrupt while the command is executed because the vector of the address match interrupt is allocated on ROM.
2. Do not use the non-maskable interrupt while Block 0 is automatically erased because the fixed bector is allocated Block 0.

Table 19.2 Interrupt in EW1 Mode

Mode	Status	When maskable interrupt request is acknowledged	When watchdog timer, oscillation stop detection and voltage detection interrupt request area acknowledged
EW1	During automatic erasing (erase-suspend function is enabled)	The auto-erasing is suspended and the interrupt process is executed. The auto-erasing can be restarted by setting the FMR41 bit in the FMR4 register to "0" (erase restart) after the interrupt process completes	Once an interrupt request is acknowledged, the auto-programming or auto-erasing is forcibly stopped and resets the flash memory. An interrupt process starts after the fixed period and the flash memory restarts. Since the block during the auto-erasing or the address during the auto-programming is forcibly stopped, the normal value may not be read. Execute the auto-erasing again and ensure the auto-erasing is completed normally. Since the watchdog timer does not stop during the command operation, the interrupt request may be generated. Reset the watchdog timer regularly using the erase-suspend function.
	During automatic erasing (erase-suspend function is disabled)	The auto-erasing has a priority and the interrupt request acknowledgement is waited. The interrupt process is executed after the auto-erasing completes	
	Auto programming	The auto-programming has a priority and the interrupt request acknowledgement is waited. The interrupt process is executed after the auto-programming completes	

## NOTES:

1. Do not use the address match interrupt while the command is executed because the vector of the address match interrupt is allocated on ROM.
2. Do not use the non-maskable interrupt while Block 0 is automatically erased because the fixed vector is allocated Block 0.

## 19.8 Noise

### (1) Bypass Capacitor between VCC and VSS Pins

Insert a bypass capacitor (at least 0.1  $\mu\text{F}$ ) between VCC and VSS pins as the countermeasures against noise and latch-up. The connecting wires must be the shortest and widest possible.

### (2) Port Control Registers Data Read Error

During severe noise testing, mainly power supply system noise, and introduction of external noise, the data of port related registers may be changed. As a firmware countermeasure, it is recommended to periodically reset the port registers, port direction registers and pull-up control registers. However, you should fully examine before introducing the reset routine as conflicts may be created between this reset routine and interrupt routines (i. e. ports are switched during interrupts).

### (3) CNVSS Pin Wiring

In order to improve the pin tolerance to noise, insert a pull down resistance (about 5 k $\Omega$ ) between CNVSS and VSS, and place it as close as possible to the CNVSS pin.



## 20. Usage notes for on-chip debugger

When using the on-chip debugger to develop the R8C/11 group program and debug, pay the following attention.

- (1) Do not use P0<sub>0</sub>/AN<sub>7</sub>/TxD<sub>11</sub> pin and P3<sub>7</sub>/TxD<sub>10</sub>/RxD<sub>1</sub> pin.
- (2) When write in the PD3 register (00E7<sub>16</sub> address), set bit 7 to "0".
- (3) Do not access the related serial interface1 register.
- (4) Do not use from OC000<sub>16</sub> address to OC7FF<sub>16</sub> address because the on-chip debugger uses these addresses.
- (5) Do not set the address match interrupt (the registers of AIER, RMAD0, RMAD1 and the fixed vector tables) in a user system.
- (6) Do not use the BRK instruction in a user system.
- (7) Do not set the b5 to "0" by a user program since the on-chip debugger uses after setting the b5 in the FMR0 register to "1".
- (8) The stack pointer with up to 8 bytes is used during the user program break. Therefore, save space of 8 bytes for the stack area.

Connecting and using the on-chip debugger has some peculiar restrictions. Refer to each on-chip debugger manual for on-chip debugger details.

### Appendix 1. Package Dimensions

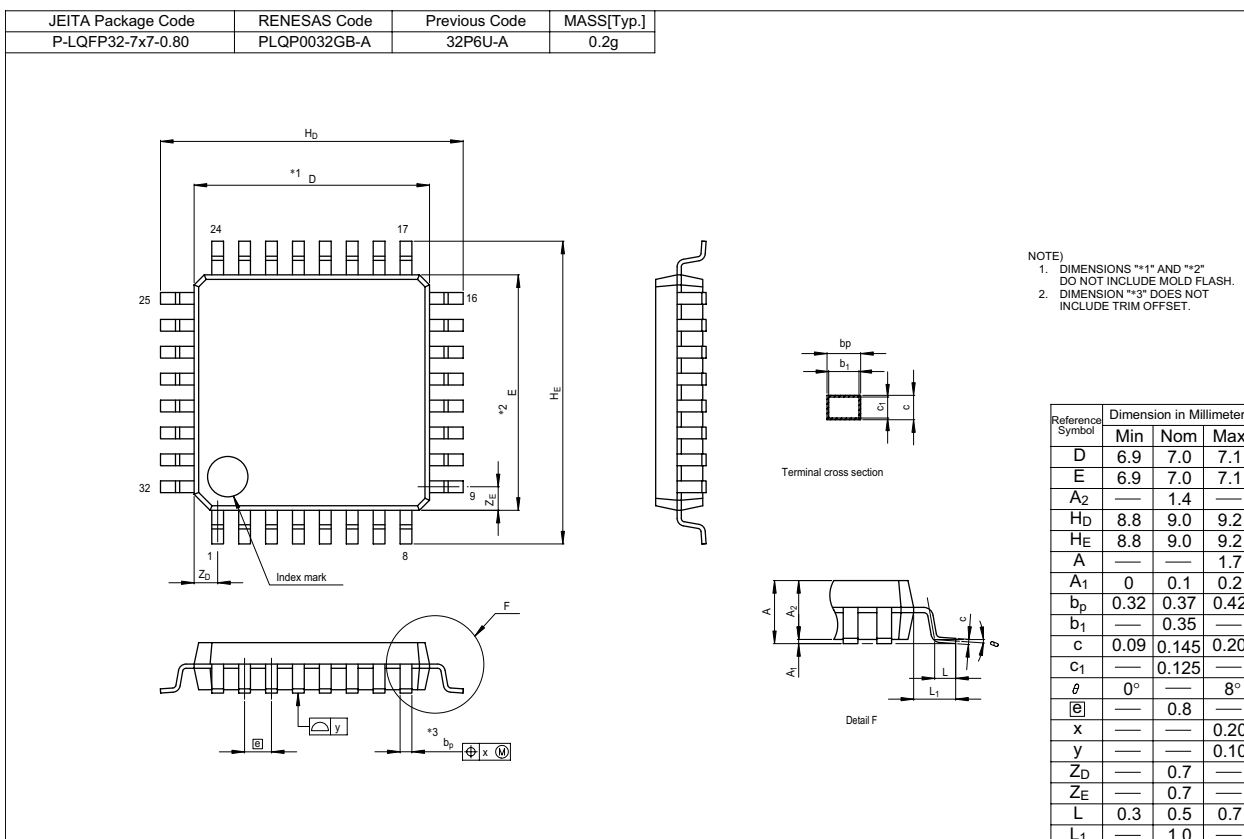





### Appendix 3. Example of Oscillation Evaluation Circuit

Appendix Figure 3.1 shows the Example of Oscillation Evaluation Circuit.

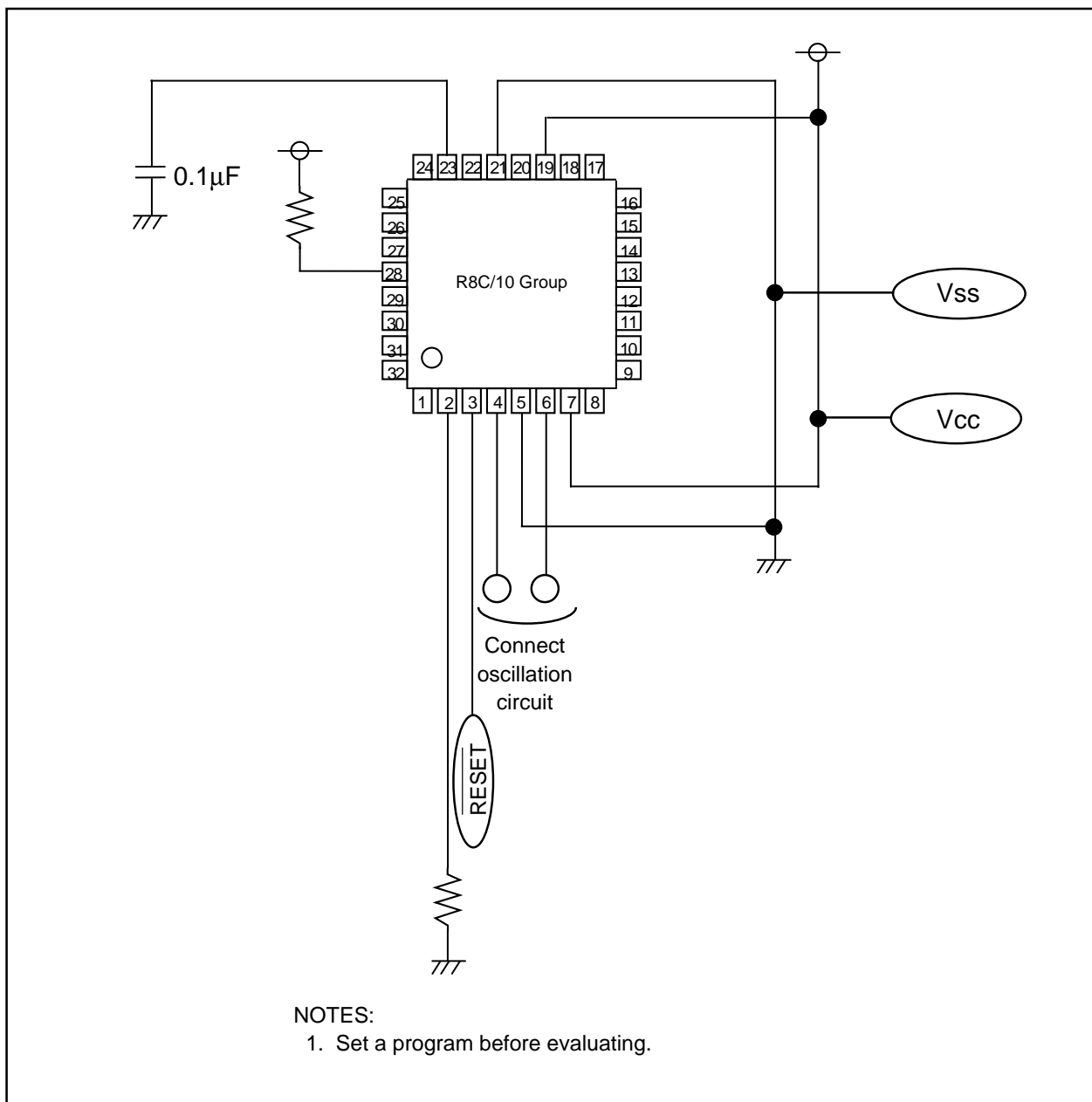

Appendix figure 3.1 Example of Oscillation Evaluation Circuit

# Register Index

## A

AD 127  
ADCON0 126, 129, 131  
ADCON1 126, 129, 131  
ADCON2 127  
ADIC 53  
AIER 67

## C

CM0 31  
CM1 31  
CMP0IC 53  
CMP1IC 53  
CMP2IC 53

## D

D4INT 23  
DRR 144

## F

FMR0 170  
FMR1 171  
FMR4 171

## H

HR0 33  
HR1 33

## I

INT0F 60  
INT0IC 53  
INT1IC 53  
INT2IC 53  
INT3IC 53  
INTEN 60

## K

KIEN 65  
KUPIC 53

## O

OCD 32

## P

P0 143  
P1 143  
P3 144  
P4 143  
PD0 143  
PD1 143  
PD3 143  
PD4 143  
PM0 45  
PM1 45  
PRCR 44  
PREX 72  
PREY 81  
PREZ 89  
PUM 82, 84, 86, 90, 92, 94, 96, 99  
PUR0 144  
PUR1 144

## R

RMAD0 67  
RMAD1 67

## S

S0RIC 53  
S0TIC 53  
S1RIC 53  
S1TIC 53

## T

TC 103  
TCC0 64, 103  
TCC1 64, 104  
TCIC 53  
TCOUT 104  
TCSS 72, 82, 90  
TM0 103

TM1 103  
TX 72  
TXIC 53  
TXMR 62, 71, 73, 74, 75, 76, 78  
TYIC 53  
TYPR 81  
TYSC 81  
TYZMR 62, 80, 84, 86, 88, 92, 94, 96, 99  
TYZOC 81, 89  
TZIC 53  
TZPR 89  
TZSC 89

## U

U0BRG 111  
U0C0 112  
U0C1 113  
U0MR 112  
U0RB 111  
U0TB 111  
U1BRG 111  
U1C0 112  
U1C1 113  
U1MR 112  
U1RB 111  
U1TB 111  
UCON 113

## V

VCR1 22  
VCR2 22

## W

WDC 69  
WDTR 69  
WDTS 69

REVISION HISTORY

R8C/11 Group Hardware Manual

Rev.	Date	Description	
		Page	Summary
0.91	Sep 08, 2003	-	First edition issued
0.92	Nov 05, 2003	2	Table 1.1 Interrupt : Revise 10 sources to 11 sources Add on Power Consumption
		4	Table 1.2 Delete **
		6	Table 1.3 CNVss and MODE : Delete ( 5kΩ ) CNVss : Add NOTES 1 Analog power supply input : Add one sentence Reference voltage input : Add one sentence
		10	Revise NOTES
		11	50 address : Revise Compare 2 to Compare 1 and CMP2IC to CMP1IC 50 address : Revise Compare 1 to Compare 0 and CMP1IC to CMP0IC
		14	Section 5.1 Add one sentence in the third line Section 5.2 Add one sentence in the fourth line Section 5.3 Add one sentence in the fourth line
		18	Revise Section 5.1.3 Revise Figure 5.6
		20	Figure 5.7 is revised
		24	Revise Figure 5.12
		26	Figure 5.13 is revised
		30	Figure 6.2 CMO : Revise on-chip oscillator to on-chip oscillator clock on NOTES 2
		32	Figure 6.4 is revised
		34	Section 6.2.2 is revised
		39	Section 6.4.3 is revised
51	Table 10.2 Revise Compare 2 to Compare 1 and Compare 1 to Compare 0		
53	Figure 10.3 50 address : Revise CMP2IC to CMP1IC 50 address : Revise CMP1IC to CMP0IC		



REVISION HISTORY

R8C/11 Group Hardware Manual

Rev.	Date	Description	
		Page	Summary
0.92	Nov 05, 2003	59	Figure 10.9 Revise Compare 1 to Compare 0 and Compare 2 to Compare 1
		62	Figure 10.13 TYZMR, TYWC bit : Revise as Function varies depending on the operation mode
		64	Figure 10.14 Tcc1, Tcc 12 bit : Revise RO to RW
		68	Figure 11.1 is revised
		71	Figure 12.1 Delete $\overline{\text{CLR}}$ of $\overline{\text{CLR}}$
		76	Table 12.5 is revised
		79	Figure 12.10 Add NOTES 7 and revise 0D16 to 0E16 Revise some parts in Figure
		80	Figure 12.11 Delete $\overline{\text{CLR}}$ of $\overline{\text{CLR}}$
		81	Figure 12.13 TYZOC NOTES 1 : Revise TYS bit to TZS bit TYPR NOTES 1 : Revise PYSC register to TYSC register
		88	Figure 12.18 Delete $\overline{\text{CLR}}$ of $\overline{\text{CLR}}$
		89	Figure 12.20 TYZOC NOTES 1 : Revise TYS bit to TZS bit Add NOTE 3
		95	Table 12.11 revised
		98	Table 12.12 revised
		101	Figure 12.28 Add "Sampling clock"
		103	Figure 12.31 TM0 and TM1 : Add setting range on output compare mode
		104	Figure 12.32 TCC1, bit 2 : Revise RO to RW NOTES are revised
		120	Table 13.5 Bit CKPOL, add "Set to "0""
131	Section 14.3 Add sentences under the sixth line Add Figure 14.6		
138	Figure 15.7 NOTES 2 and 3 : Revise its content is "0" to its content is indeterminate Figure 15.8 NOTES 1 and 2 : Revise its content is "0" to its content is indeterminate		

REVISION HISTORY

R8C/11 Group Hardware Manual

Rev.	Date	Description	
		Page	Summary
0.92	Nov 05, 2003	141	Table 16.2 Delete NOTES 3 and 4
		142	Table 16.3 Delete Tsamp Add Figure 16.1
		143	Revise Table 16.4 Revise Table 16.5 Revise Table 16.6 Add Figure 16.2 Revise Figure 16.2 to Figure 16.3 Revise Figure 16.3, Add NOTES(4)
		144	Revise Table 16.7
		146	Table 16.10 Power supply current : Revise Vcc = 4.2 to 5.5 V to 3.3 to 5.5 V Low-speed on-chip oscillator mode : Revise 100 kHz to 125 kHz High-speed mode and Medium-speed mode : Delete XIN = 5 MHz, add XIN = 16 MHz and XIN = 10 MHz TBD on High-speed mode and Medium-speed mode : Add values Low-speed on-chip oscillator/wait/stop mode : Revise data Add "VC27="0"" in wait mode
		147	Add Table 16.11 to 16.15
		148	Table 16.13 Revise NOTES 1 and 2 Add Figure 16.4
		149	Table 16.16 NOTES 1 : Revise f(BCLK) = 5 MHz to 10 MHz
		150	Table 16.17 Low-speed on-chip oscillator mode : Revise 100 kHz to 125 kHz High-speed mode and Medium-speed mode : Delete XIN = 5 MHz, add XIN = 16MHz and XIN = 10 MHz TBD on High-speed mode and Medium-speed mode : Add values Low-speed on-chip oscillator/wait/stop mode : Revise data Add "VC27="0"" in wait mode
		151	Add Table 16.18 to 16.22 Table 16.20 Revise NOTES 1 and 2

REVISION HISTORY

R8C/11 Group Hardware Manual

Rev.	Date	Description	
		Page	Summary
0.92	Nov 05, 2003	152	Add Figure 16.5
		153	Delete "Data" Retention on Table 17.1
		154	Section 17.2 Add under the eighth line
		155	Add "Voltage detection" on Figure 17.2
		160	Figure 17.4 FMR1, bit 6 : Delete "When read, its content is indeterminate" Revise RO to —
		170	Section 17.5 Add sentences
		171	Table 17.7, P46/XIN and P47/XOUT, revise sentences
		173	Figure 17.13 Add NOTES 3 Figure 17.14 Add NOTES 2
		178	Section 19.3.2 Add (1) and (4) Add Section 19.3.3 (1) Revise 19.3.3 Timer Z to 19.3.4 Timer Z Section 19.3.4 Add (1)
		184	Section 20 Add (5) and (6)
0.93	Feb 18, 2004	170-173	Add 4 pages
1.00	Sep 17, 2004	all pages	Words standardized (on-chip oscillator, serial interface, A/D)
		2	Table 1.1 revised
		5	Figure 1.3, NOTES 3 added
		6	Table 1.3 revised
		9	Figure 3.1, NOTES added
		10-13	One body sentence in chapter 4 added; Titles of Table 4.1 to 4.4 added
		12	Table 4.3 revised; Table 4.4 revised
		17	In 5.1.2, body sentences added
		21	Figure 5.8 revised
		22	Figure 5.9 revised
		23	Figure 5.10 revised

REVISION HISTORY

R8C/11 Group Hardware Manual

Rev.	Date	Description	
		Page	Summary
1.00	Sep 17,2004	24	Figure 5.11 revised
			Figure 5.12 revised
		25	Line 10 in 5.4.1 revised
			Line 5 in 5.4.2 revised
			One sentence in 5.4.2 deleted
			Table 5.3 revised
		29	Figure 6.1 revised
		30	Figure 6.2 revised (CM0 and CM1)
		31	Figure 6.3 revised
		32	Figure 6.4 revised (HR0)
		38	Table 6.3 revised
			One sentence in "Pin Status in Stop Mode" added
		42	One sentence in 6.5.1 moves to Chapter 19
		60	One body sentence in 10.2.1 added
		62	One body sentence in 10.2.3 added
		63	One body sentence in 10.2.4 added
		64	Figure 10.14 revised (TCC1)
		65	Figure 10.15 revised
		68	Figure 11.1 revised
		71	Line 4 in 12.1 revised
		74	Table 12.3 revised
		75	Table 12.4 revised
		76	Figure 12.7 revised
		78	Table 12.6 revised; Figure 12.9 revised
		83	Table 12.7 revised
		85	Table 12.8 revised, NOTES revised
		86	Figure 12.16, NOTES added
		88	5 line in 12.3 revised; Figure 12.18 revised
		91	Table 12.9 revised
		93	Table 12.10 revised, NOTES revised
		95	Table 12.11 revised, NOTES revised
		97	Figure 12.25 revised
98	Table 12.12 revised, NOTES revised		
102	Figure 12.30 revised		
103	Figure 12.31 revised (TM1 and TCC0)		
104	Figure 12.32 revised (TCC1 and TCOUT)		
105	Table 12.13 revised		
107	Table 12.14 revised		
108	Figure 12.34 revised		
110	Figure 13.2 revised		
118	13.1.3 revised		
122	Figure 13.10 revised		

REVISION HISTORY

R8C/11 Group Hardware Manual

Rev.	Date	Description	
		Page	Summary
1.00	Sep 17,2004	132	Figure numbers in 15.1.1, 15.1.2, 15.1.3 and 15.1.4 revised
		133	Figure 15.1 revised (P10 to P12)
		140	Table 15.1 revised
		141	Table 16.2 revised
		142	Table 16.3 revised
		143	Table 16.4 revised; Table 16.5 revised
		144	Table 16.6, 16.7 and 16.8 revised; Figure 16.3 revised
		145	Table 16.9 revised; Table 16.10 revised
		147	Table 16.12 revised
			Table 16.16 revised
		149	Table 16.17 revised
		151	Table 16.19 revised
		157	Line 2 and 8 in 17.4.2 revised
		158	FMR46 bit revised
		159	Figure 17.3 revised
		160	Figure 17.4 revised (FMR4)
		162	Figure 17.7 revised; Figure title revised
		163	Table 17.4 revised
		165	Figure 17.9 revised
		166	Figure 17.10 revised
168	Table 17.6 revised		
175-186	Compositions in Chapter 19 modified; 19.3 added; 19.4.5 revised; 19.7 revised		
187	(7) in Chapter 20 added		
191	Appendix 3 added		
192-193	Page numbers in Register Index revised		
1.10	Apr.27.2005	4	Table 1.2, Figure 1.2 package name revised
		5	Figure 1.3 package name revised
		10	Table 4.1 revised
		12	Table 4.3 revised
		14	5.1.1 partly revised
		15	Figure 5.2 partly revised
		19	Figure 5.6 partly added
		21	5.4 partly revised
		22	Figure 5.8 partly revised
		29	Table 6.1 partly added
		31	Figure 6.2 partly revised
		32	Figure 6.3 partly revised
		33	Figure 6.4 partly deleted
		34	6.1 partly revised
		36	6.3.1 partly deleted
		37	6.4.1 partly revised
		38	Table 6.2 partly revised
		41	Figure 6.6 revised
42	Figure 6.7 deleted		

REVISION HISTORY

R8C/11 Group Hardware Manual

Rev.	Date	Description	
		Page	Summary
1.10	Apr.27.2005	42	6.5 partly deleted Table 6.4 partly deleted 6.5.1 partly revised
		69	Figure 11.2 partly revised
		78	Figure 12.9 partly revised
		95	Table 12.11 partly revised
		98	Table 12.12 partly revised
		103	Figure12.31 partly revised
		120	Table 13.6 partly revised
		123	13.2.3 Bit Rate added
		132	Figure 14.6 partly revised 14.4 added
		133	14.5 added
		134	14.6 added
		136	Figure 15.1 revised
		137	Figure 15.2 revised
		138	Figure 15.3 revised
		139	Figure 15.4 revised
		143-148	15.2 added
		149	Table15.24 partly revised Figure 15.10 added
		151	Table 16.3 partly revised
		153	Table 16.6, 16.7 revised
		154	Table 16.9, 16.10 partly revised
		158	Table 16.17 partly revised
		163	Figure 17.1 revised
		170	Figure 17.5 added
173	•Program Command partly revised		
175	Figure 17.11 partly added		
181	Figure 17.13 package name revised		
183	18.1 partly revised		
188	19.3.2 added		
189	19.4.4 partly revised		
191	19.6 partly revised		
192	19.7.1 partly added		
196	20 partly revised		
197	Package Dimensions revised		
1.20	Jan.27.2006	2	Table 1.1 Performance outline revised
		3	Figure 1.1 Block diagram partly revised
		4	1.4 Product Information, title of Table 1.2 "Product List" → "Product Informaton" revised
			Figure 1.2 Type No., Memory Size, and Package partly revised
		6	Table 1.3 Pin description Timer C revised
		7-8	2 Central Processing Unit (CPU) revised Figure 2.1 CPU register revised
		10	Table 4.1 SFR Information(1) NOTES:1 revised
		11	Table 4.2 SFR Information(2) NOTES:1 revised

REVISION HISTORY

R8C/11 Group Hardware Manual

Rev.	Date	Description	
		Page	Summary
1.20	Jan.27.2006	12	Table 4.3 SFR Information(3); 0081 <sub>16</sub> : “Prescaler Y” → “Prescaler Y Register” 0082 <sub>16</sub> : “Timer Y Secondary” → “Timer Y Secondary Register” 0083 <sub>16</sub> : “Timer Y Primary” → “Timer Y Primary Register” 0085 <sub>16</sub> : “Prescaler Z” → “Prescaler Z Register” 0086 <sub>16</sub> : “Timer Z Secondary” → “Timer Z Secondary Register” 0087 <sub>16</sub> : “Timer Z Primary” → “Timer Z Primary Register” 008C <sub>16</sub> : “Prescaler X” → “Prescaler X Register” revised NOTES:1, 2 revised
		13	Table 4.4 SFR Information(4) NOTES:1 revised
		15	Figure 5.2 Reset Sequence; “72cycles” → “64cycles” revised
		18	5.1.3 Power-on Reset Function revised
		29	6 Clock Generation Circuit; “(oscillation stop detect function)” → “(oscillation stop detection function)” revised
			Table 6.1 Clock Generation Circuit Specifications NOTES: 2 deleted
		32	Figure 6.3 OCD Register NOTES: 3 partly deleted
		35	6.2.1 Low-Speed On-Chip Oscillator Clock; “The application products ... to accommodate the frequency range.” → “The application products ... for the frequency change.” revised
		38	Table 6.2 Setting Clock Related Bit and Modes CM13 added
		42	6.5.1 How to Use Oscillation Stop Detection Function: “This function cannot ... is below 2 MHz.” added
		46	Table 9.1 Bus Cycles for Access Space, Table 9.2 Access Unit and Bus Operation; “SFR” → “SFR, Data flash”, ROM/RAM” → “Program ROM/RAM” revised
		51	Table 10.2 Relocatable Vector Tables; “A/D” → “A/D Conversion” revised
		59	Figure 10.9 Interrupts Priority Select Circuit NOTES: 1 deleted
		71	Figure 12.1 Timer X Block Diagram; “Peripheral data bus” → “Data bus” revised
		74	Table 12.3 Pulse Output Mode Specifications NOTES: 1 added
		88	Figure 12.18 Timer Z Block Diagram; “Peripheral data bus” → “Data bus” revised
		102	Figure 12.30 CMP Waveform Output Unit revised
		107	Table 12.14 Output Compare Mode Specifications NOTES: 2 revised
		108	Figure 12.34 Operation Example of Timer C in Output Compare Mode revised
		111	Figure 13.3 U0TB to U1TB Registers, U0RB and U1RB Registers, and U0BRG and U1BRG Registers; UARTi transmit buffer register (i=0, 1) revised UARTi bit rate register (i=0, 1) ; NOTES: 3 added
		112	Figure 13.4 U0MR to U1MR Registers and U0C0 and U1C0 Registers; UARTi transmit/receive control register 0 (i=0, 1); NOTES: 1 added
		113	Figure 13.5 U0C1 and U1C1 Registers and UCON Register; UART transmit/receive control register 2; NOTES: 2 added
		120	Table 13.5 Registers to Be Used and Settings in UART Mode; UiBRG: “-” → “0 to 7” revised
		125	Figure 14.1 A/D Converter Block Diagram “Vref” → “Vcom” revised
		135	14.7 Output Impedance of Sensor under A/D Conversion added
		138	Figure 15.1 Programmable I/O Ports (1); NOTES: 1 added
		139	Figure 15.2 Programmable I/O Ports (2); NOTES: 1 added
		140	Figure 15.3 Programmable I/O Ports (3); NOTES: 1 added
		141	Figure 15.4 Programmable I/O Ports (4); NOTES: 1 added
		142	Figure 15.5 Programmable I/O Ports (5); NOTES: 3 added

REVISION HISTORY

R8C/11 Group Hardware Manual

Rev.	Date	Description	
		Page	Summary
1.20	Jan.27.2006	146	Table 15.9 Port P1 <sub>0</sub> /KI <sub>0</sub> /AN <sub>8</sub> /CMP0 <sub>0</sub> Setting; Setting value: Output port, P1 deleted
		147	Table 15.10 Port P1 <sub>1</sub> /KI <sub>1</sub> /AN <sub>9</sub> /CMP0 <sub>1</sub> Setting; Setting value: Output port, P1 deleted
			Table 15.11 Port P1 <sub>2</sub> /KI <sub>2</sub> /AN <sub>10</sub> /CMP0 <sub>2</sub> Setting; Setting value: Output port, P1 deleted
		149	Table 15.17 Port P3 <sub>0</sub> /CNTR <sub>0</sub> /CMP1 <sub>0</sub> Setting; P3 deleted
			Table 15.18 Port P3 <sub>1</sub> /TZOUT/CMP1 <sub>1</sub> Setting; P3 deleted
			Table 15.19 Port P3 <sub>2</sub> /INT <sub>2</sub> /CNTR <sub>1</sub> /CMP1 <sub>2</sub> Setting; P3 deleted
		150	Table 15.20 Port P3 <sub>3</sub> /INT <sub>3</sub> /TCIN Setting; Bit: "PD3_1" → "PD3_3" Table 15.22 Port P4 <sub>5</sub> /INT <sub>0</sub> Setting; "PD3_3" → "PD4_5"
			Table 15.23 Port X <sub>IN</sub> /P4 <sub>6</sub> , X <sub>OUT</sub> /P4 <sub>7</sub> Setting; Setting value: External input to X <sub>IN</sub> pin, "H" output from X <sub>OUT</sub> pin; CM1: "1" → "0", CM0: "0" → "1", Feedback resistance: "OFF" → "ON"
		152	Table 16.2 Recommended Operating Conditions; NOTES: 1, 2, 3 revised
		153	Table 16.3 A/D Conversion Characteristics; "A/D operation clock frequency" → "A/D operating clock frequency" revised NOTES: 1, 2, 3, 4 revised
		154	Table 16.4 Flash Memory (Program ROM) Electrical Characteristics; "Topr" → "Ambient temperature" revised Measuring condition of byte program time and block erase time deleted
		155	Table 16.6 Reset Circuit Electrical Characteristics (When Using Hardware Reset 2) NOTES: 3 (V <sub>por1</sub> ) added
		156	Table 16.8 High-speed On-Chip Oscillator Circuit Electrical Characteristics; "High-speed on-chip oscillator temperature dependence" → "High-speed on-chip oscillator frequency temperature dependence" revised
			Table 16.10 Electrical Characteristics (1) [V <sub>CC</sub> =5V]; "P1 <sub>0</sub> to P1 <sub>7</sub> Except X <sub>OUT</sub> " → "Except P1 <sub>0</sub> to P1 <sub>7</sub> , X <sub>OUT</sub> " revised
		157	Table 16.11 Electrical Characteristics (2) [V <sub>CC</sub> =5V] NOTES: 1, 2 revised Measuring condition Stop mode: "Topr = 25 °C" added
		160	Table 16.17 Electrical Characteristics (3) [V <sub>CC</sub> =3V] "P1 <sub>0</sub> to P1 <sub>7</sub> Except X <sub>OUT</sub> " → "Except P1 <sub>0</sub> to P1 <sub>7</sub> , X <sub>OUT</sub> " revised
		161	Table 16.18 Electrical Characteristics (4) [V <sub>CC</sub> =3V] NOTES: 1, 2 revised Measuring condition Stop mode: "Topr = 25 °C" added
		165	Figure 17.1 Flash Memory Block Diagram revised
171	Figure 17.4 FMR1 Register and FMR4 Register; Flash memory control register 4 NOTES: 2 "Other than this period, this bit is set to "0"." revised		
177	Figure 17.11 Block Erase Flow Chart (When Using Erase-suspend Function); "Write 'D0 <sub>16</sub> ' to the uppermost block address" → "Write 'D0 <sub>16</sub> ' to the any block address" revised		
180	Figure 17.12 Full Status Check and Handling Procedure for Each Error revised		
182	Table 17.7 Pin Functions (Flash Memory Standard Serial I/O Mode); RESET: revised		



REVISION HISTORY

R8C/11 Group Hardware Manual

Rev.	Date	Description	
		Page	Summary
1.20	Jan.27.2006	186	19.1.1 Stop Mode; "Use the next program to enter stop mode." added "• Example of entering stop mode" → "• Program of entering stop mode" "Program Example" deleted
		190	19.3.1 Oscillation Stop Detection Function "Since the oscillation stop ... is 2 MHz or below, ..." → "Since the oscillation stop ... is below 2 MHz, ..." revised
		200	Appendix figure 2.2 Connecting examples with M16C Flash Starter (M3A-0806); NOTES: 1 revised Pulled up added

---

**RENESAS 16-BIT SINGLE-CHIP MICROCOMPUTER  
HARDWARE MANUAL  
R8C/11 Group**

**Publication Data : Rev.0.93 Feb 18, 2004  
Rev.1.20 Jan 27, 2006**

**Published by : Sales Strategic Planning Div.  
Renesas Technology Corp.**

# R8C/11 Group Hardware Manual

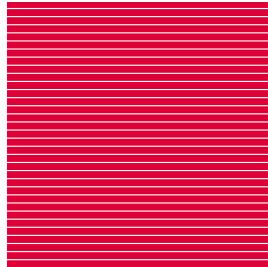

Renesas Technology Corp.  
2-6-2, Ote-machi, Chiyoda-ku, Tokyo, 100-0004, Japan