

XKB

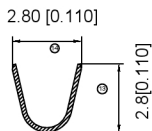

SECTION A-A  
SCALE: 1:1

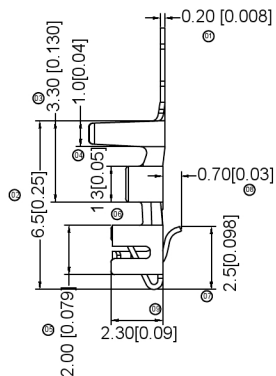
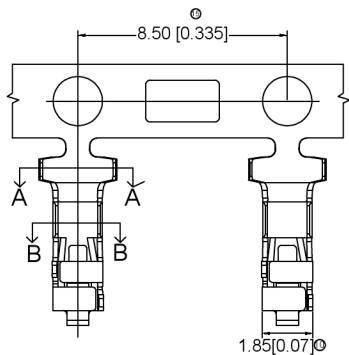
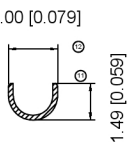

SECTION B-B  
SCALE: 1:1

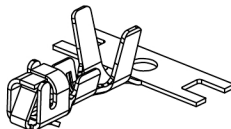

Specificationsxxb

规格:

Voltage rating:500V AC/DC

额定电压: 500V AC/DC

Current rating:3A AC/DC

额定电流: 3A AC/DC

Withstanding voltage:1000V AC/minute

耐受电压: 1000V AC/分钟

Temperature range:-25℃~+85℃

温度范围: -25℃~+85℃

Insulation resistance:≥1000MΩ

绝缘电阻: ≥1000MΩ

Contact resistance:≤10mΩ

接触电阻: ≤10mΩ XKB

After environmental testing:≤20mΩ

环境测试后: ≤20兆欧

X8821T X-X SN X-L

① ② ③ ④ ⑤ ⑥ ⑦ ⑧

- ① Series No.
- ② Category, T-Terminal
- ③ Appearance type: Blank-Ordinary
- ④ Material: P-Phosphor bronze B-Brass
- ⑤ Plating Style: SN-Bright Tin Plating
- ⑥ Plating Method:  
Blank-Stamping before Plating  
B-Plating before Stamping
- ⑦ Mold No./Mark/Special No.: L-With Lock

X8821T-BSN-L	Brass	AWG#22-26	1.90mm(Max)	Stamping Before Plating 30u" N: 70u" Sn	X 8821H-L
X8821T-BSNB-L				Plating Before stamping 10u" N: 40u" Sn	
X8821T-PSNB-L	Phosphor Bronze	AWG#22-26	1.90mm(Max)	Plating Bstfer Stamping 10u" N:40u Sn	
X8821T-PSN-L				Stampi ng Before Plating 30u" N: 70c" Sn	
PART NO	Material	Wire Range	Insulation O.D.	Finish	Used In XKB Housing

广东星坤科技股份有限公司

生 日期  
發

文件工程章

XKB	ANGLAR	±5°
	L ≤ 4	±0.2
	4 < L ≤ 16	±0.3
	16 < L ≤ 63	±0.4
	L > 63	±0.5
UNSPECIFIED TOLERANCES		

DSND	DATE	SCALE: NA	MODEL TYPE:
DWNN	DATE	VIEW:	PART NO.:
CHKD	DATE	UNIT: mm/in	2.54 mm Crimp Style Connectors
APPD	DATE	SIZE: A4	DWG NO.:
XKB INDUSTRIAL PRECISION CO., LIMITED			WEIGHT
			1.0g
			SHEET
			1/1
			REVISION
			A0

REVISIONS  
DATE REVISED APPROVED  
www.heloxkb.com