

MAIN FEATURE

1. Miniature size 12.1x17.2x16.2mm on SAM-1P for smaller occupying space.
2. Easy P.C. Board design available as the location of contact terminal separated from each contact.
3. Distinctive twin relay structure on SAM-2P providing high performance for the use of automotive.
4. Both washable and flux proofed types available.
5. Comply with RoHS, REACH and ELV regulations.

CONTACT RATING

Load Type	SAM-1P (DM/DB)	SAM-1P (D)	SAM-2P (DM/DB)	SAM-2P (D)
Rated Load (Resistive)	N.O.: 10A 24VDC	N.O.: 10A 24VDC	N.O.: 15A 15VDC	N.O.: 15A 15VDC
	N.C.: 7A 24VDC	N.C.: 7A 24VDC	N.C.: 10A 15VDC	N.C.: 10A 15VDC
Rated Carrying Current	10A	10A	15A	15A
Max. Allowable Voltage	DC 30V	DC 30V	DC 30V	DC 30V
Max. Allowable Current	10A	10A	15A	15A
Max. Allowable Power Force	240W	240W	240W	240W
Contact Material	Ag Alloy	Ag Alloy	Ag Alloy	Ag Alloy
Contact Form	SPST	SPDT	DPST	DPDT

APPLICATION

Lighting Control, Central Door Lock Control, Power Window Control, Power Door Control, Sunroof Control

PERFORMANCE (AT INITIAL VALUE)

- Contact Resistance 100 mΩ Max. @1A, 6VDC
- Operate Time 10 mSec. Max.
- Release Time 5 mSec. Max.
- Dielectric Strength:
 - Between Coil & Contact 1,000VAC at 50/60 Hz for one minute
 - Between Contacts 500VAC at 50/60 Hz for one minute
- Surge Strength 2000V (between coil & contact 1.2x50μSec.)
- Insulation Resistance 100 MegaΩ Min. at 500VDC
- Max. On/Off Switching:
 - Electrical 6 Cycles per Minute
 - Mechanical 300 Cycles per Minute
- Temperature Range -40~+85°C
- Humidity Range 45~85% RH.
- Coil Temperature Rise 60°C Max.

- Vibration:
 - Destruction 10 to 55 to 10 Hz, 0.75 mm single amplitude (1.5mm double amplitude)
 - Malfunction 10 to 55 to 10 Hz, 0.75 mm single amplitude (1.5mm double amplitude)
- Shock:
 - Destruction 1,000 m/S²
 - Malfunction 100 m/S²
- Life Expectancy:
 - Mechanical 10⁷ Operations at No Load condition
 - Electrical 10⁵ Operations at Rated Resistive Load
- Weight SAM-1P: 8g
SAM-2P: 15.2g

SAFETY STANDARD & FILE NUMBER

- NIL

COIL SPECIFICATION (AT 20°C)

Coil Sensitivity	Nominal Voltage (VDC)	Nominal Current (mA)	Coil Resistance ($\Omega \pm 10\%$)	Power Consumption (W)	Pull-In Voltage (VDC)	Drop-Out Voltage (VDC)	Maximum Allowable Voltage (VDC)
SAM-1P SAM-2P	5	91	55	Abt. 0.45	75% Maximum	5% Minimum	150% (for short time carrying current)
	6	75	80				
	9	50	180				
	12	38	320				
	18	25	720				
	24	19	1,280				

ORDERING INFORMATION

SAM - SS - 1 12 D M

Contact Form:

Nil: One Form C

M: One Form A

B: One Form B

Coil Type:

D: Standard DC

Coil Voltage:

05: 5V, **06:** 6V, **09:** 9V, **12:** 12V, **18:** 18V, **24:** 24V

Number of Pole:

1: One Pole

2: Two Poles

Type of Sealing:

SS: RT II Flux Proofed

SH: RT III Wash Tight

Type:

SAM

CLASSIFICATION

Model	SAM					
	1 Pole			2 Poles		
Number Of Pole	1 Pole			2 Poles		
Contact Form	1C	1A	1B	2C	2A	2B
Flux Proofed	SAM-SS-1□□D	SAM-SS-1□□DM	SAM-SS-1□□DB	SAM-SS-2□□D	SAM-SS-2□□DM	SAM-SS-2□□DB
Wash Tight	SAM-SH-1□□D	SAM-SH-1□□DM	SAM-SH-1□□DB	SAM-SH-2□□D	SAM-SH-2□□DM	SAM-SH-2□□DB

DIMENSION (≤ 5mm ± 0.2mm, > 5mm ± 0.3mm, the tolerance of PCB thru hole: +0.1mm)

SAM-SS/SH(1P)

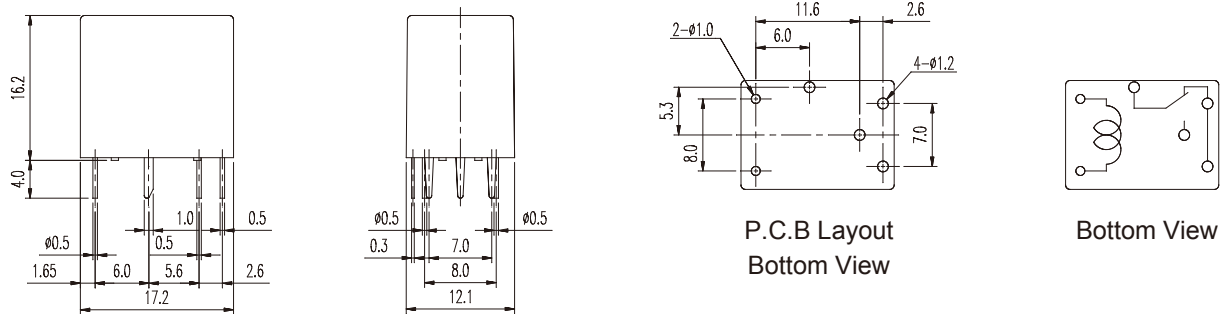

SAM-SS/SH(2P)

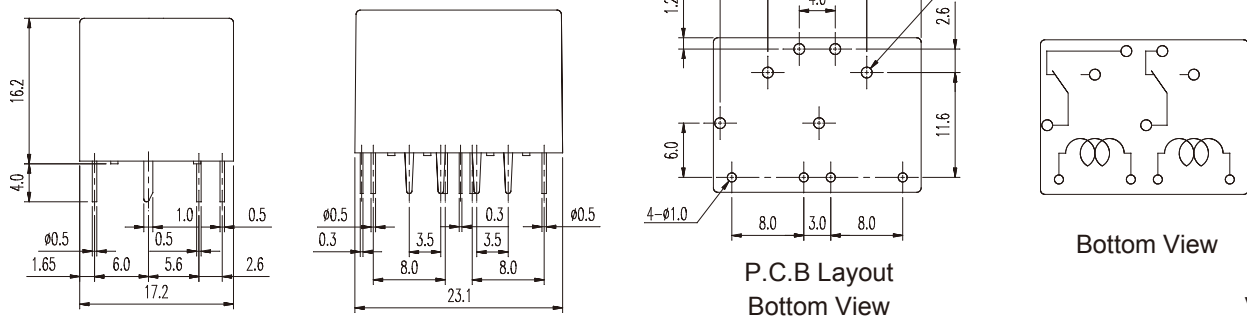

V.01EZ