

AZ764

16 A SPDT MINIATURE POWER RELAY

FEATURES

- Dielectric strength 5000 Vrms
- Low height: 15.7 mm
- Epoxy sealed version available
- 16 Amp switching (High inrush version 80A available)
- AC and DC coils
- Isolation spacing greater than 10 mm
- Proof tracking index (PTI/CTI) 250
- Reinforced insulation, EN 60730-1 (VDE 0631, part 1) EN 60335-1 (VDE 0700, part 1)
- UL, CUR file E43203
- VDE certificate 40012572



CONTACTS

Arrangement	SPDT (1 Form C) SPST (1 Form A)
Ratings	Resistive load: Max. switched power: 480 W or 5000 VA Max. switched current: 16 A Max. switched voltage: 300 VDC* or 400 VAC * Note: If switching voltage is greater than 30 VDC, special precautions must be taken. Please contact the factory.
Rated Load UL, CUR VDE	16 A at 250 VAC, General use [1][2] 1 Form A - DC coil 16 A at 250 VAC, 30k cycles, 85°C [1] 16 A at 250 VAC, 10k cycles, 85°C [2] 20 A at 250 VAC, 10k cycles, 85°C [2] * * approved with open vent hole only 1 Form A - AC coil 16 A at 250 VAC, 30k cycles, 70°C [1] 16 A at 250 VAC, 40k cycles, 70°C [2] 1 Form C - DC coil 16 A at 250 VAC, 10k cycles, 70°C [1] 16 A at 250 VAC, 10k cycles, 85°C [2] 1 Form C - AC coil 16 A at 250 VAC, 10k cycles, 70°C [1][2]
Material	Silver nickel [1], silver tin oxide [2]
Resistance	< 100 miliohms initially

NOTES

1. All values at 20°C (68°F).
2. Relay may pull in with less than "Must Operate" value.
3. Specifications subject to change without notice.

GENERAL DATA

Life Expectancy Mechanical Electrical	Minimum operations 3 x 10 ⁷ 7 x 10 ⁴ at 16 A 250 VAC res.
Operate Time (typical)	7 ms at nominal coil voltage
Release Time (typical)	3 ms at nominal coil voltage (with no coil suppression)
Dielectric Strength (at sea level for 1 min.)	5000 Vrms coil to contact 1000 Vrms between open contacts
Insulation Resistance	10 ⁵ megohms min. at 500 VDC, 20°C, 50% RH
Insulation (according to DIN VDE 0110, IEC 60664-1)	B250 at 1 Form C, flux proof version C250 at other relay versions Overvoltage category: III Pollution degree: 3 Nominal voltage: 250 VAC
Dropout DC coils AC coils	Greater than 10% of nominal coil voltage Greater than 15% of nominal coil voltage
Ambient Temperature Operating	At nominal coil voltage -40°C (-40°F) to 85°C (185°F) - DC coils -40°C (-40°F) to 70°C (158°F) - AC coils
Vibration	Break contacts: 5 g at 20...500 Hz Make contacts: 20 g at 30...500 Hz
Shock	20 g
Enclosure	P.B.T. polyester, UL-94 : V0
Terminals	Tinned copper alloy, P.C.
Max. Solder Temp.	270°C (518°F)
Max. Solder Time	5 seconds
Max. Solvent Temp.	80°C (176°F)
Max. Immersion Time	30 seconds
Weight	14 grams
Packing unit in pcs	20 per carton tube / 1000 per carton box

COIL

Power	
At Pickup Voltage (typical)	200 mW (DC coil) .422 VA (AC coil)
Max. Continuous Dissipation	1.7 W at 20°C (68°F) ambient 1.7 VA at 20°C (68°F) ambient
Temperature Rise	26°C (47°F) at nominal coil voltage
Max. Temperature	155°C (311°F) Class F

ZETTLER electronics GmbH

Junkersstr. 3, D-82178 Puchheim, Germany

phone: +49 89 800 97-0 office@ZETTLERelectronics.com

fax: +49 89 800 97-200 www.ZETTLERelectronics.com

This product specification to be used only together with the application notes which can be downloaded from <http://www.ZETTLERelectronics.com/pdfs/relais/ApplicationNotes.pdf>

2013-02-26

AZ764

RELAY ORDERING DATA

COIL SPECIFICATIONS - DC COIL				ORDER NUMBER*	
Nominal Coil VDC	Must Operate VDC	Max. Continuous VDC	Coil Resistance Ohm $\pm 10\%$	1 Form A	1 Form C
3	2.1	7.6	22	AZ764-1A-3D	AZ764-1C-3D
5	3.5	12.7	60	AZ764-1A-5D	AZ764-1C-5D
6	4.2	15.3	90	AZ764-1A-6D	AZ764-1C-6D
9	6.3	22.9	200	AZ764-1A-9D	AZ764-1C-9D
12	8.4	30.6	360	AZ764-1A-12D	AZ764-1C-12D
18	12.6	45.9	710	AZ764-1A-18D	AZ764-1C-18D
24	16.8	61.2	1,440	AZ764-1A-24D	AZ764-1C-24D
36	25.2	92.0	3,140	AZ764-1A-36D	AZ764-1C-36D
48	33.6	122.0	5,700	AZ764-1A-48D	AZ764-1C-48D
60	42.0	153.0	7,500	AZ764-1A-60D	AZ764-1C-60D
110	77.0	280.0	25,200	AZ764-1A-110D	AZ764-1C-110D

COIL SPECIFICATIONS - AC COIL					ORDER NUMBER*	
Nominal Coil VAC	Must Operate VAC	Max. Continuous VAC	Nominal Current mA $\pm 10\%$	Coil Resistance Ohm $\pm 10\%$	1 Form A	1 Form C
12	9.0	18.0	63.0	100	AZ764-1A-12A	AZ764-1C-12A
24	18.0	36.0	31.3	400	AZ764-1A-24A	AZ764-1C-24A
48	36.0	72.0	15.6	1,550	AZ764-1A-48A	AZ764-1C-48A
60	45.0	90.0	12.5	2,600	AZ764-1A-60A	AZ764-1C-60A
110	82.5	165.0	6.8	8,900	AZ764-1A-110A	AZ764-1C-110A
115	86.3	172.5	6.5	9,600	AZ764-1A-115A	AZ764-1C-115A
120	90.0	180.0	6.3	10,200	AZ764-1A-120A	AZ764-1C-120A
220	165.0	330.0	3.4	35,500	AZ764-1A-220A	AZ764-1C-220A
230	172.5	345.0	3.3	38,500	AZ764-1A-230A	AZ764-1C-230A
240	180.0	360.0	3.1	42,500	AZ764-1A-240A	AZ764-1C-240A

* "1A" or "1C" denote silver nickel contacts.

Substitute "1AE" or "1CE" in place of "1A" or "1C" for silver tin oxide contacts.

Substitute "1AT" in place of "1A" for high inrush 80A silver tin oxide contacts. (DC coils only)

Add suffix "E" at the end of order number for sealed version.

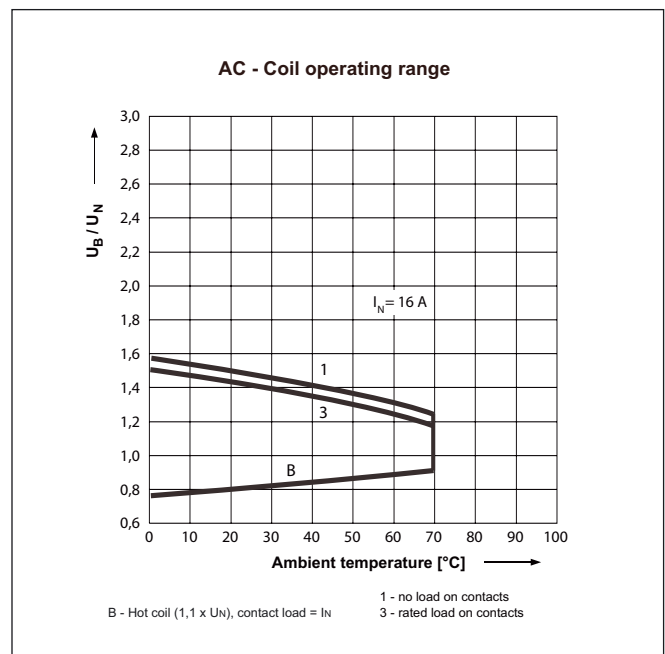
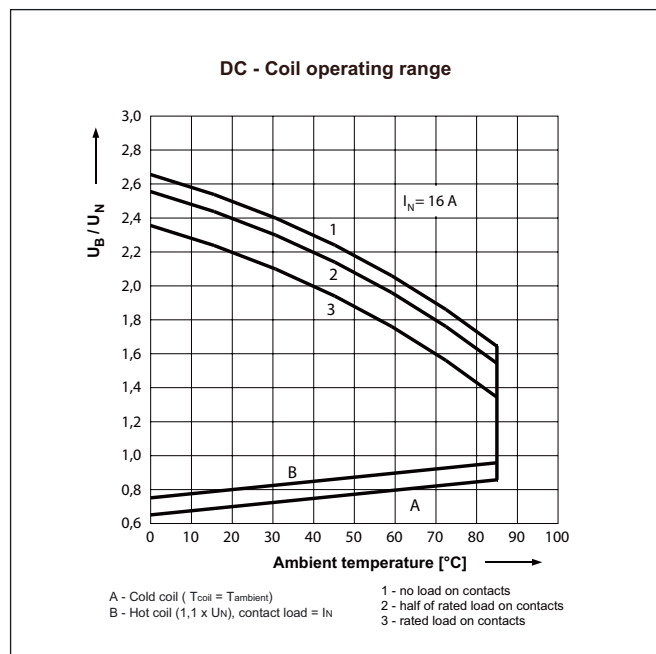

ZETTLER electronics GmbH

Junkersstr. 3, D-82178 Puchheim, Germany

phone: +49 89 800 97-0 office@ZETTLERelectronics.com

fax: +49 89 800 97-200 www.ZETTLERelectronics.com

This product specification to be used only together with the application notes which can be downloaded from <http://www.ZETTLERelectronics.com/pdfs/relais/ApplicationNotes.pdf>

2013-02-26

AZ764

MECHANICAL DATA

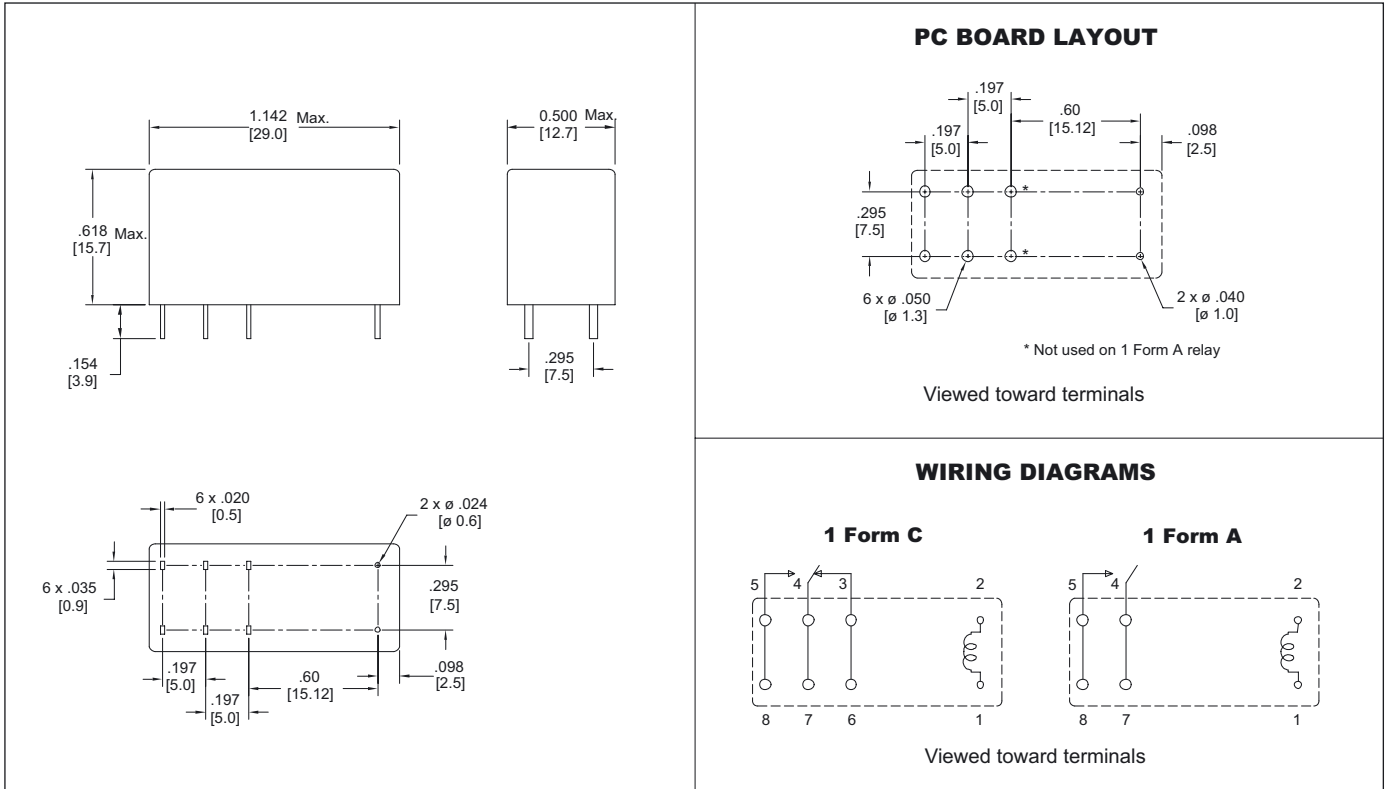

Dimensions in inches with metric equivalents in parentheses. Tolerance: $\pm .010$ "

ACCESSORIES

For P.C.B. mount: Socket EC 50
Retaining Clip MP 16 / MH 16



For DIN rail mount: Socket ES 50
Retaining Clip MS 16

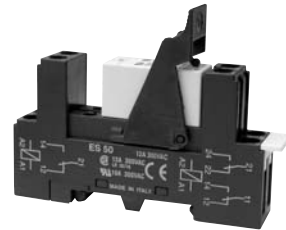

MECHANICAL DATA

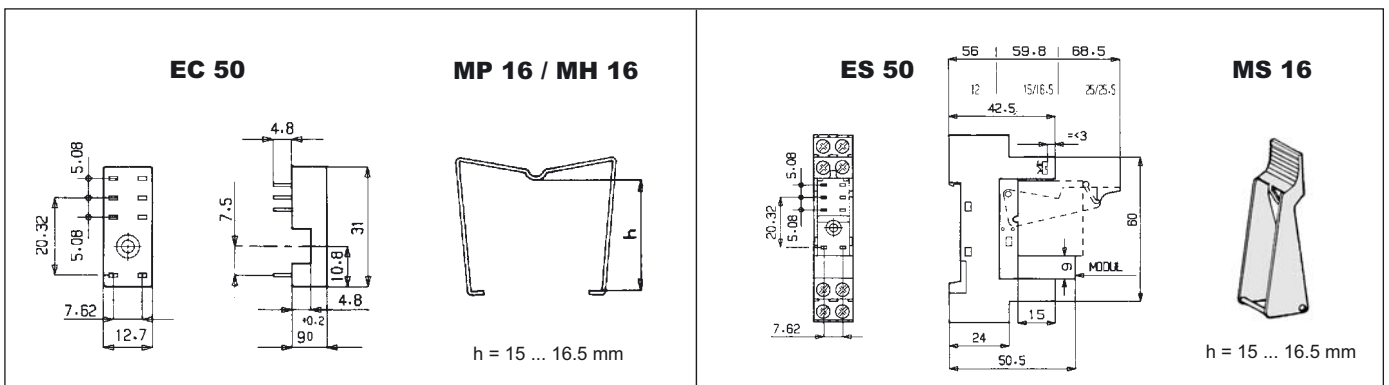

ZETTLER electronics GmbH

Junkersstr. 3, D-82178 Puchheim, Germany

phone: +49 89 800 97-0 office@ZETTLERelectronics.com

fax: +49 89 800 97-200 www.ZETTLERelectronics.com

This product specification to be used only together with the application notes which can be downloaded from <http://www.ZETTLERelectronics.com/pdfs/relais/ApplicationNotes.pdf>

2013-02-26

Electrical life at 250 VAC, resistive load

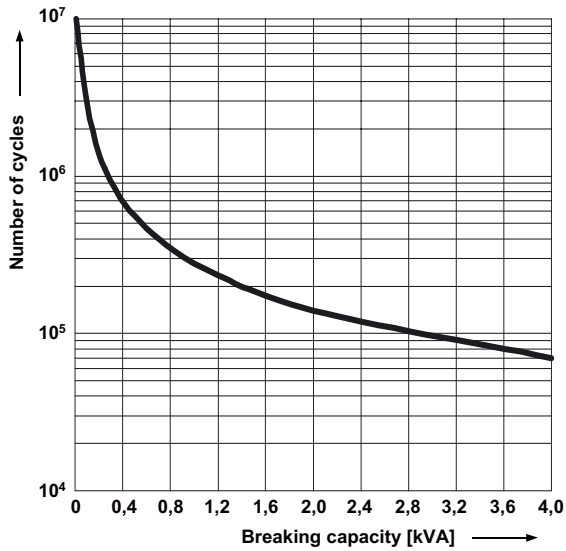

Electrical life reduction factor at inductive AC load

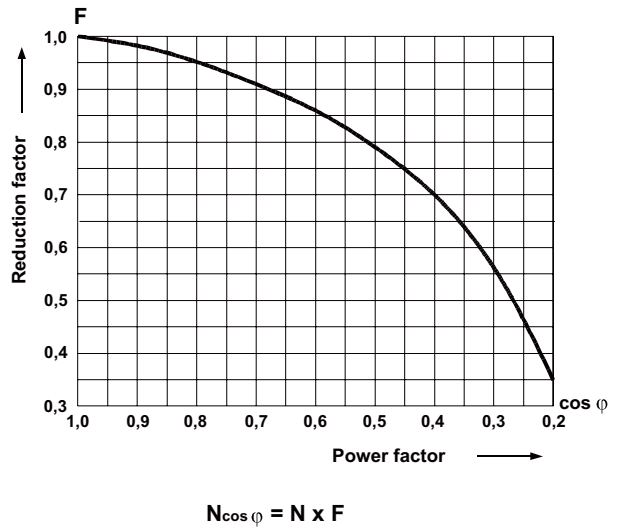

Max. DC resistive load breaking capacity

