



## UP2518

Preliminary

PNP TRANSISTOR

### LOW $V_{CE(SAT)}$ PNP SILICON POWER TRANSISTORS

#### FEATURES

- \*Extremely low collector-emitter saturation voltage  $V_{CE(SAT)}$  and corresponding extremely low equivalent on-resistance  $R_{CE(SAT)}$  (97mΩ at 1.5A)
- \*High collector current capability(1.5A)
- \*High peak pulse current up to 6A
- \*High collector current gain

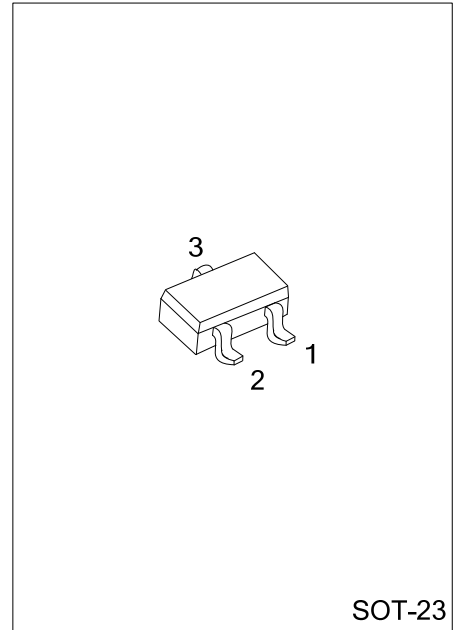

#### ORDERING INFORMATION

Ordering Number		Package	Pin Assignment			Packing
Lead Free	Halogen Free		1	2	3	
UP2518L-AE3-R	UP2518G-AE3-R	SOT-23	E	B	C	Tape Reel

<p>UP2518L-AE3-R</p> <p>(1)Packing Type</p> <p>(2)Package Type</p> <p>(3)Lead Plating</p>	<p>(1) R: Tape Reel</p> <p>(2) AE3: SOT-23</p> <p>(3) G: Halogen Free, L: Lead Free</p>
---	---

#### MARKING

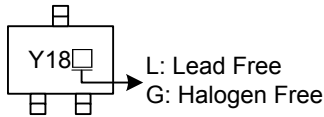

ABSOLUTE MAXIMUM RATING ( $T_a = 25^\circ\text{C}$ , unless otherwise stated)

PARAMETER	SYMBOL	RATINGS	UNIT
Collector-Base Voltage	$V_{CB0}$	-20	V
Collector-Emitter Voltage	$V_{CEO}$	-20	V
Emitter-Base Voltage	$V_{EBO}$	-5	V
Peak Pulse Current (Note 2)	$I_{PEAK}$	-6	A
Continuous Collector Current	$I_C$	-1.5	A
Base Current	$I_B$	-500	mA
Power Dissipation (Note 3)	$T_a = 25^\circ\text{C}$ $P_D$	625	mW
Junction Temperature	$T_J$	+150	$^\circ\text{C}$
Storage Temperature	$T_{STG}$	-55~+150	$^\circ\text{C}$

Notes: 1. Absolute maximum ratings are those values beyond which the device could be permanently damaged.

Absolute maximum ratings are stress ratings only and functional device operation is not implied.

2. Pulse width=300 $\mu\text{s}$ . Duty cycle $\leq 2\%$ 

3. Assume the device is mounted and measured on a ceramic substrate 15x15x0.6mm

■ ELECTRICAL CHARACTERISTICS ( $T_a = 25^\circ\text{C}$ , unless otherwise stated)

PARAMETER	SYMBOL	TEST CONDITIONS	MIN	TYP	MAX	UNIT
Collector-Base Breakdown Voltage	$BV_{CB0}$	$I_C = -100\mu\text{A}$	-20	-65		V
Collector-Emitter Breakdown Voltage	$BV_{CEO}$	$I_C = -10\text{mA}$ (Note)	-20	-55		V
Emitter-Base Breakdown Voltage	$BV_{EBO}$	$I_E = -100\mu\text{A}$	-5	-8.8		V
Collector Cut-Off Current	$I_{CBO}$	$V_{CB} = -15\text{V}$			-100	nA
Emitter Cut-Off Current	$I_{EBO}$	$V_{EB} = -4\text{V}$			-100	nA
Collector Emitter Cut-Off Current	$I_{CES}$	$V_{CES} = -15\text{V}$			-100	nA
Collector-Emitter Saturation Voltage	$V_{CE(SAT)}$	$I_C = -100\text{mA}$ , $I_B = -10\text{mA}$ (Note)		-16	-40	mV
		$I_C = -1\text{A}$ , $I_B = -20\text{mA}$ (Note)		-130	-200	mV
		$I_C = -1.5\text{A}$ , $I_B = -50\text{mA}$ (Note)		-145	-220	mV
Base-Emitter Saturation Voltage	$V_{BE(SAT)}$	$I_C = -1.5\text{A}$ , $I_B = -50\text{mA}$ (Note)		-0.87	-1.0	V
Base-Emitter Turn-On Voltage	$V_{BE(ON)}$	$V_{CE} = -2\text{V}$ , $I_C = -2\text{A}$ (Note)		-0.81	-1.0	V
DC Current Gain	$h_{FE}$	$V_{CE} = -2\text{V}$ , $I_C = -10\text{mA}$ (Note)	300	475		
		$V_{CE} = -2\text{V}$ , $I_C = -100\text{mA}$ (Note)	300	450		
		$V_{CE} = -2\text{V}$ , $I_C = -2\text{A}$ , (Note)	150	230		
		$V_{CE} = -2\text{V}$ , $I_C = -4\text{A}$ , (Note)	35	70		
		$V_{CE} = -2\text{V}$ , $I_C = -6\text{A}$ , (Note)	15	30		
Transition Frequency	$f_T$	$V_{CE} = -10\text{V}$ , $I_C = -50\text{mA}$ , $f = 100\text{MHz}$	150	180		MHZ
Output Capacitance	$C_{OB}$	$V_{CB} = -10\text{V}$ , $f = 1\text{MHz}$		21	30	pF
Turn-On Time	$t_{(ON)}$	$V_{CC} = -10\text{V}$ , $I_C = -1\text{A}$		40		ns
Turn-Off Time	$t_{(OFF)}$	$I_{B1} = I_{B2} = -20\text{mA}$		670		ns

Note: Measured under pulsed conditions. Pulse width=300 $\mu\text{s}$ . Duty cycle $\leq 2\%$

UTC assumes no responsibility for equipment failures that result from using products at values that exceed, even momentarily, rated values (such as maximum ratings, operating condition ranges, or other parameters) listed in products specifications of any and all UTC products described or contained herein. UTC products are not designed for use in life support appliances, devices or systems where malfunction of these products can be reasonably expected to result in personal injury. Reproduction in whole or in part is prohibited without the prior written consent of the copyright owner. The information presented in this document does not form part of any quotation or contract, is believed to be accurate and reliable and may be changed without notice.