

# NHD-C12832A1Z-FSR-FBW-3V3

## COG (Chip-On-Glass) Liquid Crystal Display Module

NHD-	Newhaven Display
C12832-	128 x 32 Pixels
A1Z-	Model
F-	Transflective
SR-	Red LED Edge Backlight
F-	FSTN Positive
B-	6:00 Optimal View
W-	Wide Temp
3V3-	3V <sub>DD</sub> , 3V Backlight
	<b>RoHS Compliant</b>

**Newhaven Display International, Inc.**

2661 Galvin Ct.

Elgin IL, 60124

Ph: 847-844-8795

Fax: 847-844-8796

[www.newhavendisplay.com](http://www.newhavendisplay.com)

[nhtech@newhavendisplay.com](mailto:nhtech@newhavendisplay.com)

[nhsales@newhavendisplay.com](mailto:nhsales@newhavendisplay.com)

## Document Revision History

Revision	Date	Description	Changed by
0	11/12/2008	Initial Release	-
1	9/27/2010	User guide reformat	BE
2	5/6/2013	Electrical and Optical characteristics updated. Pin description, wiring diagram, mechanical drawing page and example initialization program updated.	JN
3	1/24/17	Mechanical Drawing, Electrical & Optical Char. Updated	SB

## Functions and Features

- 128 x 32 pixels
- 4-line SPI MPU interfaces
- Built-in ST7565R controller
- +3.0V power supply
- 1/33 duty cycle; 1/6 bias
- RoHS Compliant

# Mechanical Drawing

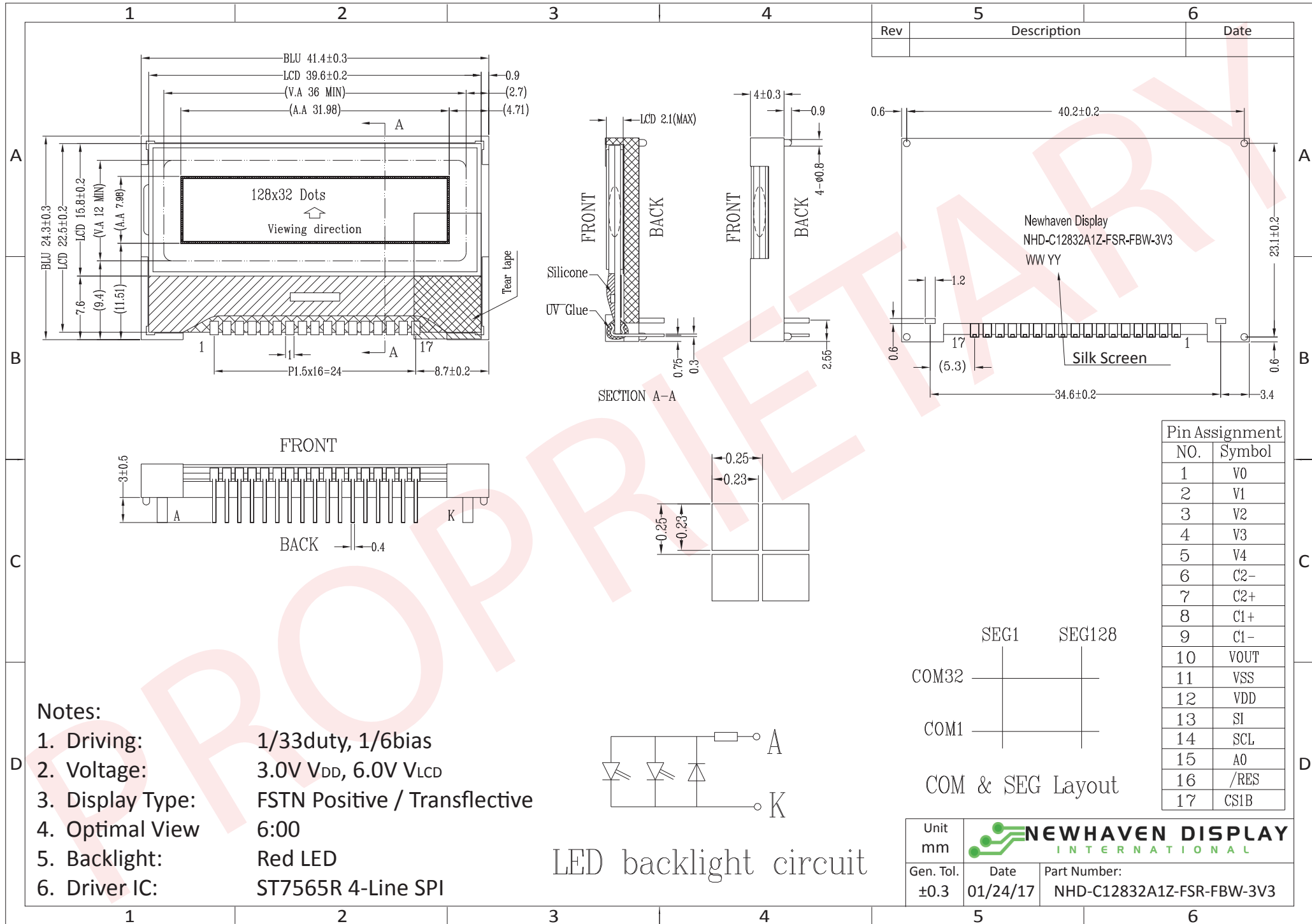

## Pin Description and Wiring Diagram

Pin No.	Symbol	External Connection	Function Description
1	V <sub>0</sub>	Power Supply	0.1μF – 1μF Capacitor to V <sub>SS</sub>
2	V <sub>1</sub>	Power Supply	0.1μF – 1μF Capacitor to V <sub>SS</sub>
3	V <sub>2</sub>	Power Supply	0.1μF – 1μF Capacitor to V <sub>SS</sub>
4	V <sub>3</sub>	Power Supply	0.1μF – 1μF Capacitor to V <sub>SS</sub>
5	V <sub>4</sub>	Power Supply	0.1μF – 1μF Capacitor to V <sub>SS</sub>
6	C2-	Power Supply	Connect 1μF – 2.2μF Capacitor to C2+ (pin 7)
7	C2+	Power Supply	Connect 1μF – 2.2μF Capacitor to C2- (pin 6)
8	C1+	Power Supply	Connect 1μF – 2.2μF Capacitor to C1- (pin 9)
9	C1-	Power Supply	Connect 1μF – 2.2μF Capacitor to C1+ (pin 8)
10	V <sub>OUT</sub>	Power Supply	Connect 1μF – 2.2μF Capacitor to V <sub>SS</sub> (pin 11)
11	V <sub>SS</sub>	Power Supply	Ground
12	V <sub>DD</sub>	Power Supply	Supply Voltage for LCD and Logic (+3V)
13	SI	MPU	Serial Data
14	SCL	MPU	Serial Clock
15	A0	MPU	Register Select. A0=0: Instruction, A0=1: Data
16	/RST	MPU	Active LOW Reset signal
17	/CS1	MPU	Active LOW Chip Select signal
A	LED+	Power Supply	Backlight Anode(+3V )
K	LED-	Power Supply	Backlight Cathode (Ground)

**Recommended LCD connector:** 1.5mm pitch pins, solder directly into PCB

**Backlight connector:** 1.2mm Wide pins, solder directly into PCB **Mates with:** ---

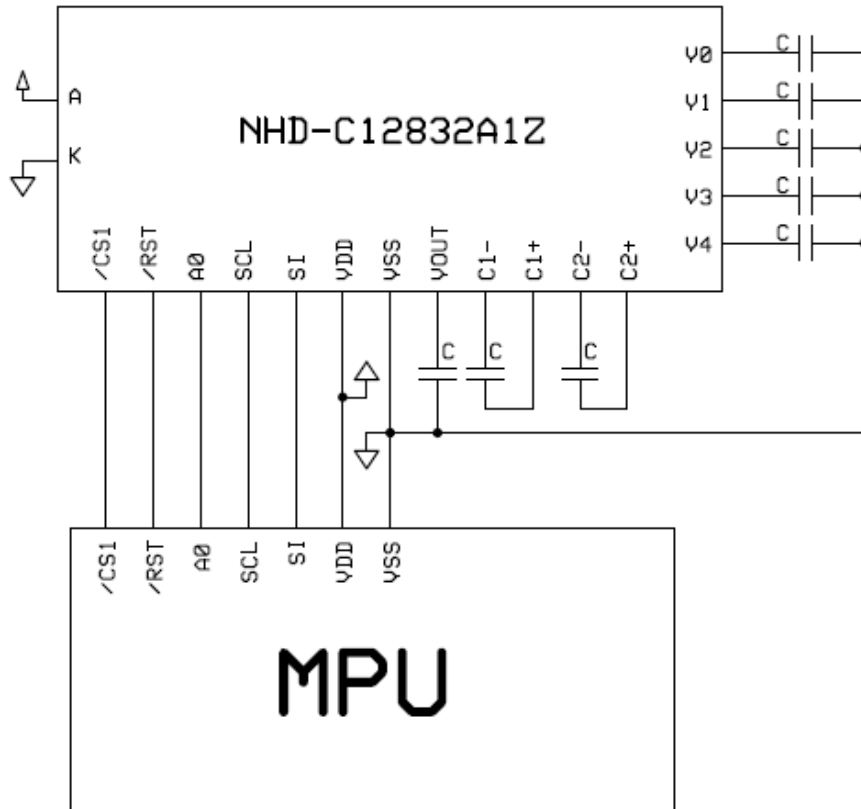

## Electrical Characteristics

Item	Symbol	Condition	Min.	Typ.	Max.	Unit
Operating Temperature Range	$T_{OP}$	Absolute Max	-20	-	+70	°C
Storage Temperature Range	$T_{ST}$	Absolute Max	-30	-	+80	°C
Supply Voltage	$V_{DD}$	-	2.7	3.0	3.3	V
Supply Current	$I_{DD}$	$V_{DD}=3.0V$ $T_{OP}=25^{\circ}C$	0.1	0.4	1.0	mA
Supply for LCD (contrast)	$V_{LCD}$		5.8	6.0	6.2	V
"H" Level input	$V_{IH}$	-	$0.8 * V_{DD}$	-	$V_{DD}$	V
"L" Level input	$V_{IL}$	-	$V_{SS}$	-	$0.2 * V_{DD}$	V
"H" Level output	$V_{OH}$	-	$0.8 * V_{DD}$	-	$V_{DD}$	V
"L" Level output	$V_{OL}$	-	$V_{SS}$	-	$0.2 * V_{DD}$	V
Backlight supply voltage	$V_{LED}$	-	2.9	3.0	3.1	V
Backlight supply current	$I_{LED}$	$V_{LED}=3.0V$	10	20	26	mA

## Optical Characteristics

Item	Symbol	Condition	Min.	Typ.	Max.	Unit
Optimal Viewing Angles	Top	$CR \geq 2$	-	20	-	°
	Bottom		-	40	-	°
	Left		-	40	-	°
	Right		-	40	-	°
Contrast Ratio	CR	-	2	8	-	-
Response Time	Rise	$T_{OP}=25^{\circ}C$	-	200	250	ms
	Fall		-	250	320	ms

## Controller Information

Built-in ST7565R controller.

Please download specification at [http://www.newhavendisplay.com/app\\_notes/ST7565R.pdf](http://www.newhavendisplay.com/app_notes/ST7565R.pdf)

# Timing Characteristics

The 4-line SPI Interface

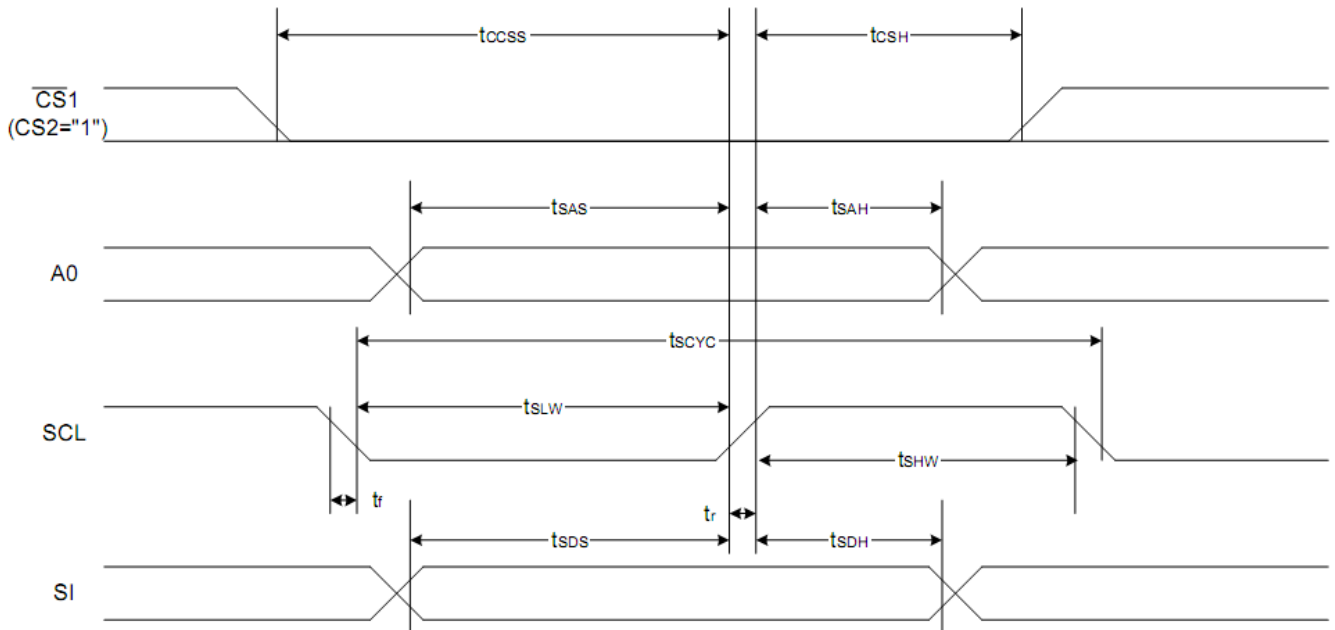

Item	Signal	Symbol	Condition	Rating		Units
				Min.	Max.	
4-line SPI Clock Period	SCL	$T_{scyc}$		50	—	ns
SCL "H" pulse width		$T_{shw}$		25	—	
SCL "L" pulse width		$T_{slw}$		25	—	
Address setup time	A0	$T_{sas}$		20	—	
Address hold time		$T_{sah}$		10	—	
Data setup time	SI	$T_{sds}$		20	—	
Data hold time		$T_{sdh}$		10	—	
CS-SCL time	CS	$T_{css}$		20	—	
CS-SCL time		$T_{csh}$		40	—	

\*1 The input signal rise and fall time ( $t_r$ ,  $t_f$ ) are specified at 15 ns or less.

\*2 All timing is specified using 20% and 80% of  $V_{DD}$  as the standard.

## Reset Timing

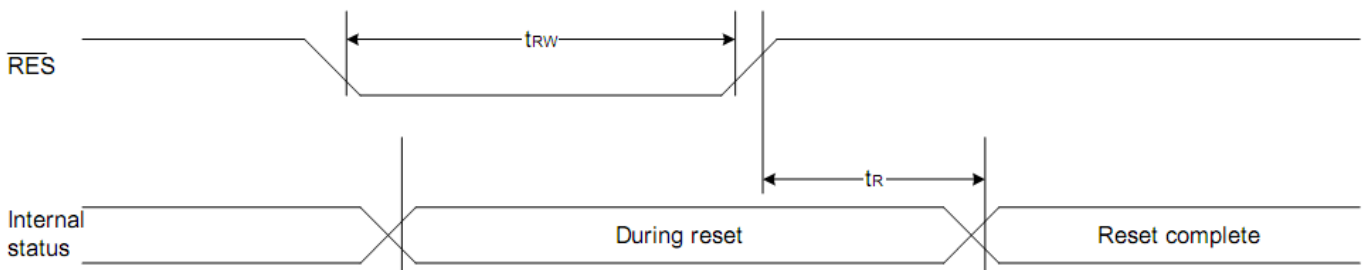

## Table of Commands

Command	Command Code									Function				
	A0	/RD	/WR	D7	D6	D5	D4	D3	D2		D1	D0		
(1) Display ON/OFF	0	1	0	1	0	1	0	1	1	1	0	1	LCD display ON/OFF 0: OFF, 1: ON	
(2) Display start line set	0	1	0	0	1	Display start address					0	Sets the display RAM display start line address		
(3) Page address set	0	1	0	1	0	1	1	Page address				0	Sets the display RAM page address	
(4) Column address set upper bit	0	1	0	0	0	0	1	Most significant column address				0	Sets the most significant 4 bits of the display RAM column address.	
Column address set lower bit				0	0	0	0	Least significant column address				0	Sets the least significant 4 bits of the display RAM column address.	
(5) Status read	0	0	1	Status				0	0	0	0	0	Reads the status data	
(6) Display data write	1	1	0	Write data							0	Writes to the display RAM		
(7) Display data read	1	0	1	Read data							0	Reads from the display RAM		
(8) ADC select	0	1	0	1	0	1	0	0	0	0	0	0	Sets the display RAM address SEG output correspondence 0: normal, 1: reverse	
(9) Display normal/reverse	0	1	0	1	0	1	0	0	1	1	0	1	Sets the LCD display normal/ reverse 0: normal, 1: reverse	
(10) Display all points ON/OFF	0	1	0	1	0	1	0	0	1	0	0	0	1	Display all points 0: normal display 1: all points ON
(11) LCD bias set	0	1	0	1	0	1	0	0	0	1	0	1	Sets the LCD drive voltage bias ratio 0: 1/9 bias, 1: 1/7 bias (ST7565R)	
(12) Read-modify-write	0	1	0	1	1	1	0	0	0	0	0	0	Column address increment At write: +1 At read: 0	
(13) End	0	1	0	1	1	1	0	1	1	1	0	0	Clear read/modify/write	
(14) Reset	0	1	0	1	1	1	0	0	0	1	0	0	Internal reset	
(15) Common output mode select	0	1	0	1	1	0	0	0	*	*	*	1	Select COM output scan direction 0: normal direction 1: reverse direction	
(16) Power control set	0	1	0	0	0	1	0	1	Operating mode			0	Select internal power supply operating mode	
(17) V <sub>0</sub> voltage regulator internal resistor ratio set	0	1	0	0	0	1	0	0	Resistor ratio			0	Select internal resistor ratio(Rb/Ra) mode	
(18) Electronic volume mode set	0	1	0	1	0	0	0	0	0	0	0	1	Set the V <sub>0</sub> output voltage electronic volume register	
Electronic volume register set				0	0	Electronic volume value					0			
(19) Sleep mode set	0	1	0	1	0	1	0	1	1	0	0	0	0: Sleep mode, 1: Normal mode	
(20) Booster ratio set	0	1	0	1	1	1	1	1	0	0	0	0	select booster ratio 00: 2x,3x,4x 01: 5x 11: 6x	
(21) NOP	0	1	0	1	1	1	0	0	0	1	1	1	Command for non-operation	
(22) Test	0	1	0	1	1	1	1	*	*	*	*	*	Command for IC test. Do not use this command	

## Example Initialization Program

```
void data_out(unsigned char i) //Data Output Serial Interface
{
    unsigned int n;
    CS = 0;
    A0 = 1;
    for(n=0; n<8; n++){
        i <<=1;
        SCL = 0;
        P1 = i;
        delay(2);
        SCL = 1;
    }
    CS = 1;
}

void comm_out(unsigned char j) //Command Output Serial Interface
{
    unsigned int n;
    CS = 0;
    A0 = 0;
    for(n=0; n<8; n++){
        j <<=1;
        SCL = 0;
        P1 = j;
        delay(2);
        SCL = 1;
    }
    CS = 1;
}

/*****
*      Initialization For controller      *
*****/
void init_LCD()
{
    comm_out(0xA0);
    comm_out(0xAE);
    comm_out(0xC0);
    comm_out(0xA2);
    comm_out(0x2F);
    comm_out(0x21);
    comm_out(0x81);
    comm_out(0x3F);
}
/*****/
```



## Quality Information

Test Item	Content of Test	Test Condition	Note
High Temperature storage	Endurance test applying the high storage temperature for a long time.	+80°C , 96hrs	2
Low Temperature storage	Endurance test applying the low storage temperature for a long time.	-30°C , 96hrs	1,2
High Temperature Operation	Endurance test applying the electric stress (voltage & current) and the high thermal stress for a long time.	+70°C , 96hrs	2
Low Temperature Operation	Endurance test applying the electric stress (voltage & current) and the low thermal stress for a long time.	-20°C , 96hrs	1,2
High Temperature / Humidity Operation	Endurance test applying the electric stress (voltage & current) and the high thermal with high humidity stress for a long time.	+40°C, 90% RH, 96hrs	1,2
Thermal Shock resistance	Endurance test applying the electric stress (voltage & current) during a cycle of low and high thermal stress.	-0°C, 30min -> 25°C, 5min -> 50°C, 30min = 1 cycle For 10 cycles	
Vibration test	Endurance test applying vibration to simulate transportation and use.	10-55Hz, 1.5mm amplitude. 60 sec in each of 3 directions X,Y,Z For 15 minutes	3
Static electricity test	Endurance test applying electric static discharge.	VS=4KV, RS=330Ω, CS=150pF Five times	

**Note 1:** No condensation to be observed.

**Note 2:** Conducted after 4 hours of storage at 25°C, 0%RH.

**Note 3:** Test performed on product itself, not inside a container.

## Precautions for using LCDs/LCMs

See Precautions at [www.newhavendisplay.com/specs/precautions.pdf](http://www.newhavendisplay.com/specs/precautions.pdf)

## Warranty Information and Terms & Conditions

[http://www.newhavendisplay.com/index.php?main\\_page=terms](http://www.newhavendisplay.com/index.php?main_page=terms)