

947-120
Jam Nut Mount Hermetic Bulkhead Feed-Thru
.062/.125ⁱⁿ Panel
MIL-DTL-38999 Series II Type

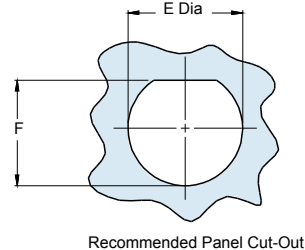

MIL-DTL
38999 Type

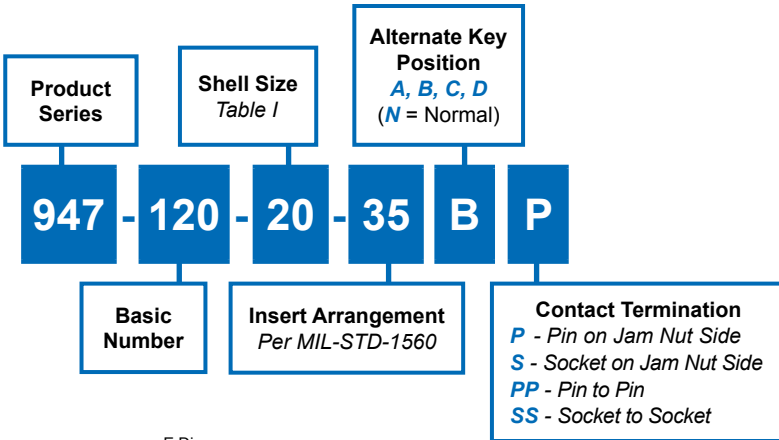

HERMETIC LEAK RATE MOD CODES	
Designator	Required Leak Rate
-585A	1 x 10 ⁻¹⁰ cc's Helium per second
-585B	1 x 10 ⁻⁹ cc's Helium per second
-585C	1 x 10 ⁻⁸ cc's Helium per second

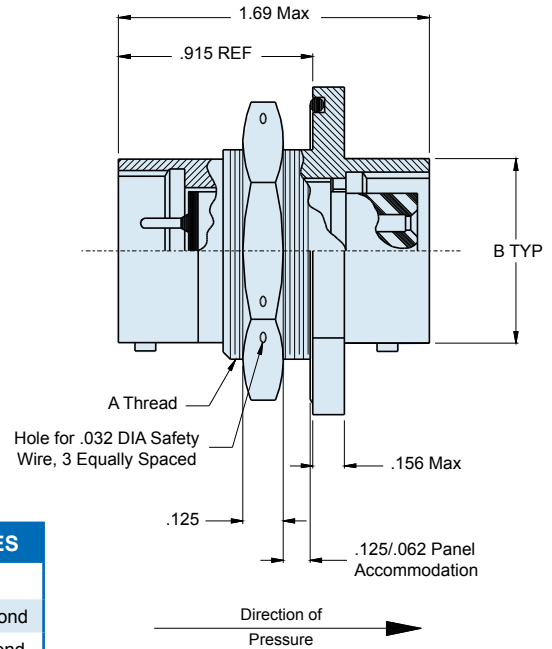
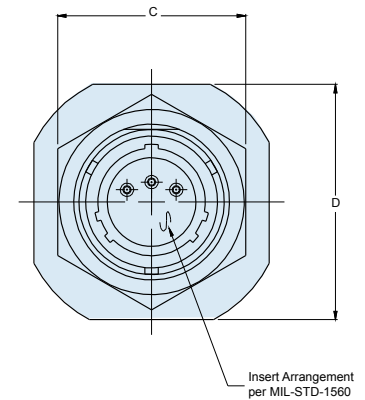

TABLE I: CONNECTOR DIMENSIONS						
SHELL SIZE	A THREAD CLASS 2A	B DIA MAX	C HEX	D FLATS	E DIA ±.005(0.1)	F +.000-.005 (0-0.1)
08	.875-20 UNEF	.474(12.0)	1.062(27.0)	1.250(31.8)	.885(22.5)	.830(21.1)
10	1.000-20 UNEF	.591(15.0)	1.188(30.2)	1.375(34.9)	1.010(25.7)	.955(24.3)
12	1.125-18 UNEF	.751(19.1)	1.312(33.3)	1.500(38.1)	1.135(28.8)	1.085(27.6)
14	1.250-18 UNEF	.876(22.3)	1.438(36.5)	1.625(41.3)	1.260(32.0)	1.210(30.7)
16	1.375-18 UNEF	1.001(25.4)	1.562(39.7)	1.781(45.2)	1.385(35.2)	1.335(33.9)
18	1.500-18 UNEF	1.126(28.6)	1.688(42.9)	1.890(48.0)	1.510(38.4)	1.460(37.1)
20	1.625-18 UNEF	1.251(31.8)	1.812(46.0)	2.016(51.2)	1.635(41.5)	1.585(40.3)
22	1.750-18 UNS	1.376(35.0)	2.000(50.8)	2.140(54.4)	1.760(44.7)	1.710(43.4)
24	1.875-16 UN	1.501(38.1)	2.125(54.0)	2.265(57.5)	1.885(47.9)	1.835(46.6)



APPLICATION NOTES

- Assembly identified with manufacturer's name and part number, space permitting.
- For pin/pin or socket/socket, symmetrical layouts only consult factory for available insert arrangements).
- Power to a given contact on one end will result in power to contact directly opposite, regardless of identification letter.
- Hermeticity = less than 1 x 10⁻⁷ cc/sec at one atmosphere.
- Not for use in liquid atmosphere.
- Material/Finish:
Shell, lock ring, jam nut, bayonet pins—stainless steel/passivate
Contacts—copper alloy/gold plate and alloy 52/gold plate
Insulators—high-grade rigid dielectric/N.A. and full glass
Seals - silicone/ N.A.
- Metric Dimensions (mm) are indicated in parentheses.