

VIEW WITH ASSEMBLED COVER  
 ANSICHT MIT MONTIERTEM DECKEL

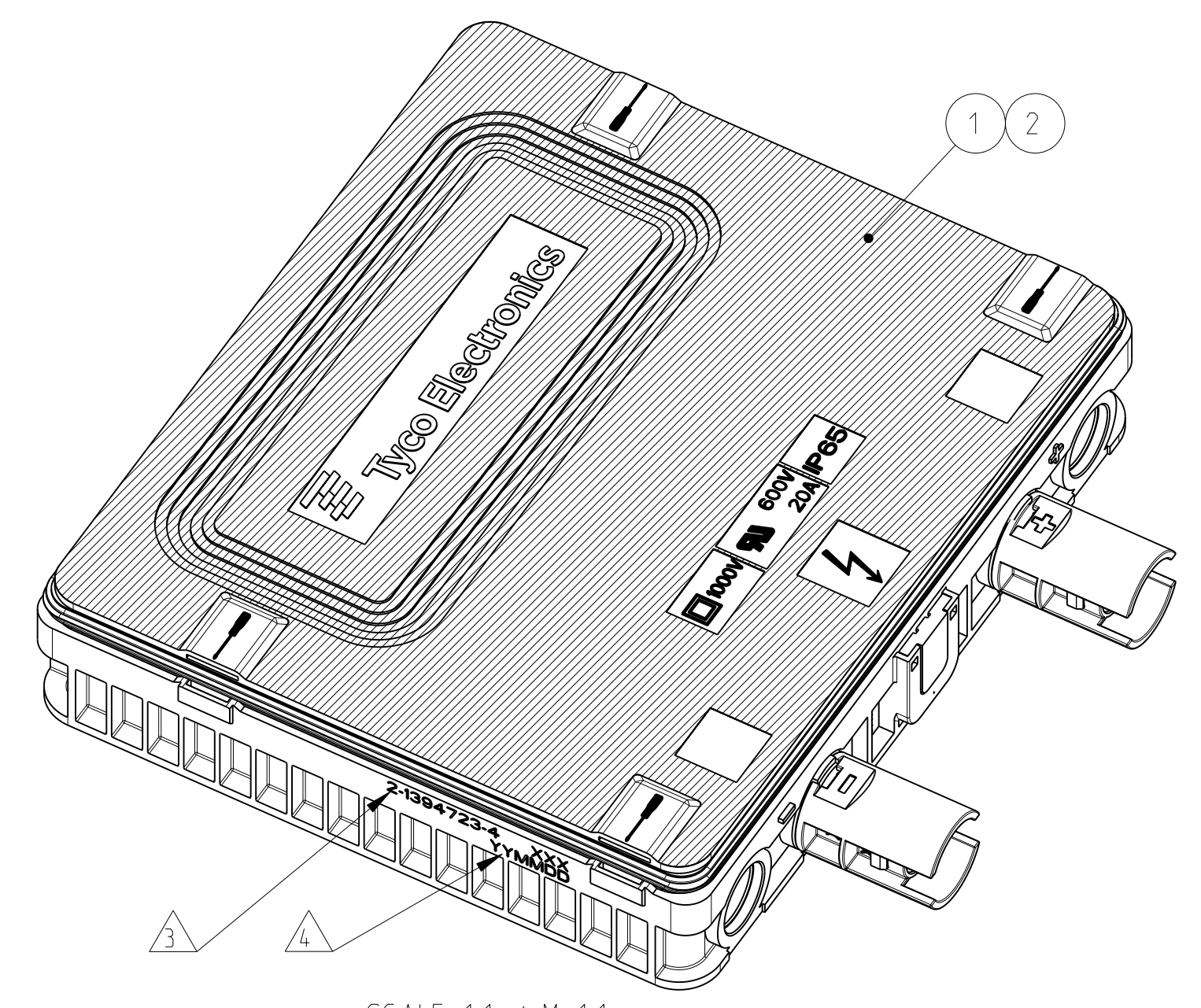

SCALE 1:1 / M 1:1

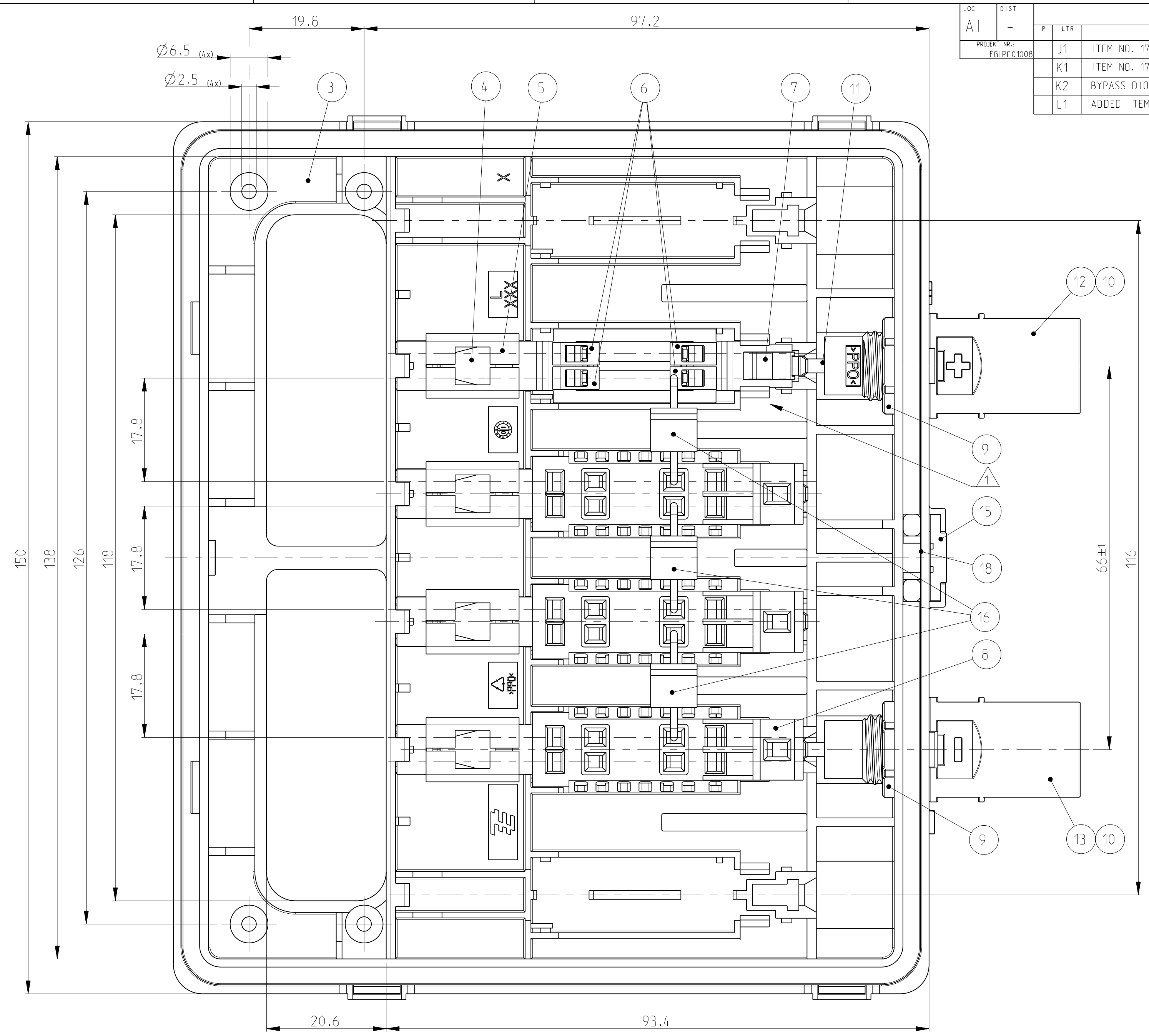
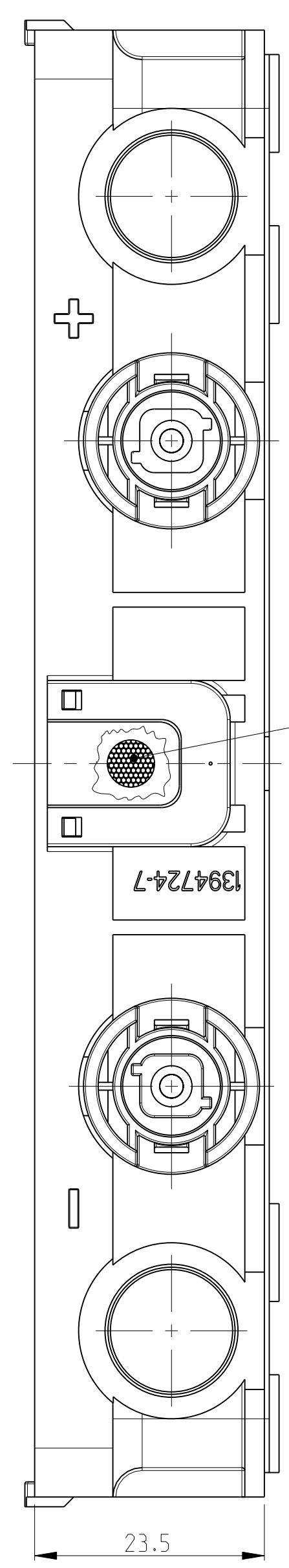

LOC	DIST	REV	DATE	BY	APP'D
A1	-	J1	24-FEB-04	EW	GF
		K1	13-MAR-06	EW	GF
		K2	17-NOV-08	CST	GF
		L1	15-JUN-2009	AL	AW

- ⚠ ITEM NO. 8 NOT SHOWN
- ⚠ PART NUMBER
- ⚠ PRODUCTION DATE
- ⚠ SOLAR MODULE BOX COVER ITEM NO. 1 AND SEALING ITEM NO. 2 NOT SHOWN. COVER NOT ASSEMBLED WITH LOWER PART. ENCLOSE LOOSELY.

- ⚠ POS. 8 NICHT DARGESTELLT
- ⚠ TEILENUMMER
- ⚠ FERTIGUNGSDATUM
- ⚠ SOLAR MODUL BOX DECKEL POS. 1 AND DICHTUNG POS. 2 NICHT DARGESTELLT. DECKEL NICHT MIT UNTERTEIL MONTIERT. LOSE BEIGELEGT.

**PACKAGING SEE 1394723-1**  
**VERPACKUNG SIEHE 1394723-1**

2- -4 AS SHOWN  
 2- -4 WIE GEZEICHNET

ITEM NO. POS.	QTY. STK.	DESCRIPTION	SURFACE COLOUR/FARBE	MATERIAL
18	1	ADHESIVE MEMBRANE VENTS KLEBEPAD SELBSTKLEBEND	-	-
17	6	ADHESIVE SPLICING PAD DOUBLE SIDED SELBSTKLEBEPAD DOPPELSEITIG	-	-
16	3	BYPASS DIODE TYPE: F1200D	-	-
15	1	COVER ABDECKUNG	BLACK SCHWARZ	PPD PPD
14	1	FILTER ELEMENT FILTERELEMENT	-	-
13	1	PIN HOUSING MINUS CODING STIFTGEHÄUSE MINUS KODIERUNG	BLACK SCHWARZ	PPD PPD
12	1	PIN HOUSING PLUS CODING STIFTGEHÄUSE PLUS KODIERUNG	BLACK SCHWARZ	PPD PPD
11	2	CONTACT PIN Ø2.4 KONTAKTSTIFT Ø2.4	Ag Ag	CU58 CU58
10	2	O-RING 9x2	-	-
9	2	NUT M12x1.5 MÜTTER M12x1.5	ZINC PLATED VERZINKT	CuZn CuZn
8	4	COVER FOR CONTACT RAIL ABDECKUNG FÜR STROMSCHIENE	BLACK SCHWARZ	PLT PLT
7	4	SPRING CLAMP FRÜHGEFEDER	-	STAINLESS STEEL ROSTFREIER STAHL
6	16	AMP SPRING CLAMP WITH ANTI OVERSTRESS AMP-ANFRÜHGEFEDER MIT ÜBERDEHNSCHUTZ	PLAIN BLANK	STAINLESS STEEL ROSTFREIER STAHL
5	4	CONTACT RAIL STROMSCHIENE	PRESILVER VORVER SILBERT	CuMo CuMo
4	4	FOIL SPRING FÖLIEFEDER	PLAIN BLANK	STAINLESS STEEL ROSTFREIER STAHL
3	1	SOLAR MODULE BOX LOWER PART. 2 POS. SOLAR MODUL BOX UNTERTEIL. 2-FACH	BLACK SCHWARZ	PPD PPD
2	1	SEALING RADIAL SEAL DICHTUNG RADIALDICHT	BLACK SCHWARZ	PP/EPDM PP/EPDM
1	1	SOLAR MODULE BOX COVER SOLAR MODUL BOX DECKEL	BLACK SCHWARZ	PPD PPD

ORDER NO. BESTELL-NR.	ITEM NO. POS.	QTY. STK.	DESCRIPTION	DESCRIPTION	DESCRIPTION
2-1394723-4					
DIMENSIONS: MASSE/MAßSTÄBE: mm TOLERANCES: UNLESS OTHERWISE SPECIFIED: ALLE DIMENSIONEN			DIMENSIONS: MASSE/MAßSTÄBE: mm TOLERANCES: UNLESS OTHERWISE SPECIFIED: ALLE DIMENSIONEN		
MATERIAL: - FINISH/SCHWARZFÄRBE: -			MATERIAL: - FINISH/SCHWARZFÄRBE: -		
DWG: E. WERNER 27-MAY-03 CHK: H. SCHERER 27-MAY-03 APVD: E. FELDMAYER 27-MAY-03			DWG: E. WERNER 27-MAY-03 CHK: H. SCHERER 27-MAY-03 APVD: E. FELDMAYER 27-MAY-03		
PRODUCT SPEC: 108-10701 APPLICATION SPEC: VERARBEITUNGSSPEZ. 114-104-00			PRODUCT SPEC: 108-10701 APPLICATION SPEC: VERARBEITUNGSSPEZ. 114-104-00		
WEIGHT: - DIMENSIONS: 114-104-00			WEIGHT: - DIMENSIONS: 114-104-00		
CUSTOMER DRAWING			CUSTOMER DRAWING		
NAME: SOLARLOK MODULE BOX, ASSY SOLARLOK MODUL BOX, ASSY			NAME: SOLARLOK MODULE BOX, ASSY SOLARLOK MODUL BOX, ASSY		
SIZE: A1 CAGE CODE: 00779 DRAWING NO: C=2-1394723-4			SIZE: A1 CAGE CODE: 00779 DRAWING NO: C=2-1394723-4		
RESTRICTED TO: NUR FÜR: -			RESTRICTED TO: NUR FÜR: -		
SCALE: MASSSTAB 2:1 SHEET: BLATT 1 OF 2 REV: L1			SCALE: MASSSTAB 2:1 SHEET: BLATT 1 OF 2 REV: L1		

LOC	DIST	REVISIONS			
		NO.	DATE	BY	APPV
A1	-	1	24-FEB-04	H. SCHNEIDER	
PROJECT NO. EGEPC01008		SEE SHEET 1			

REAR VIEW  
RÜCKANSICHT

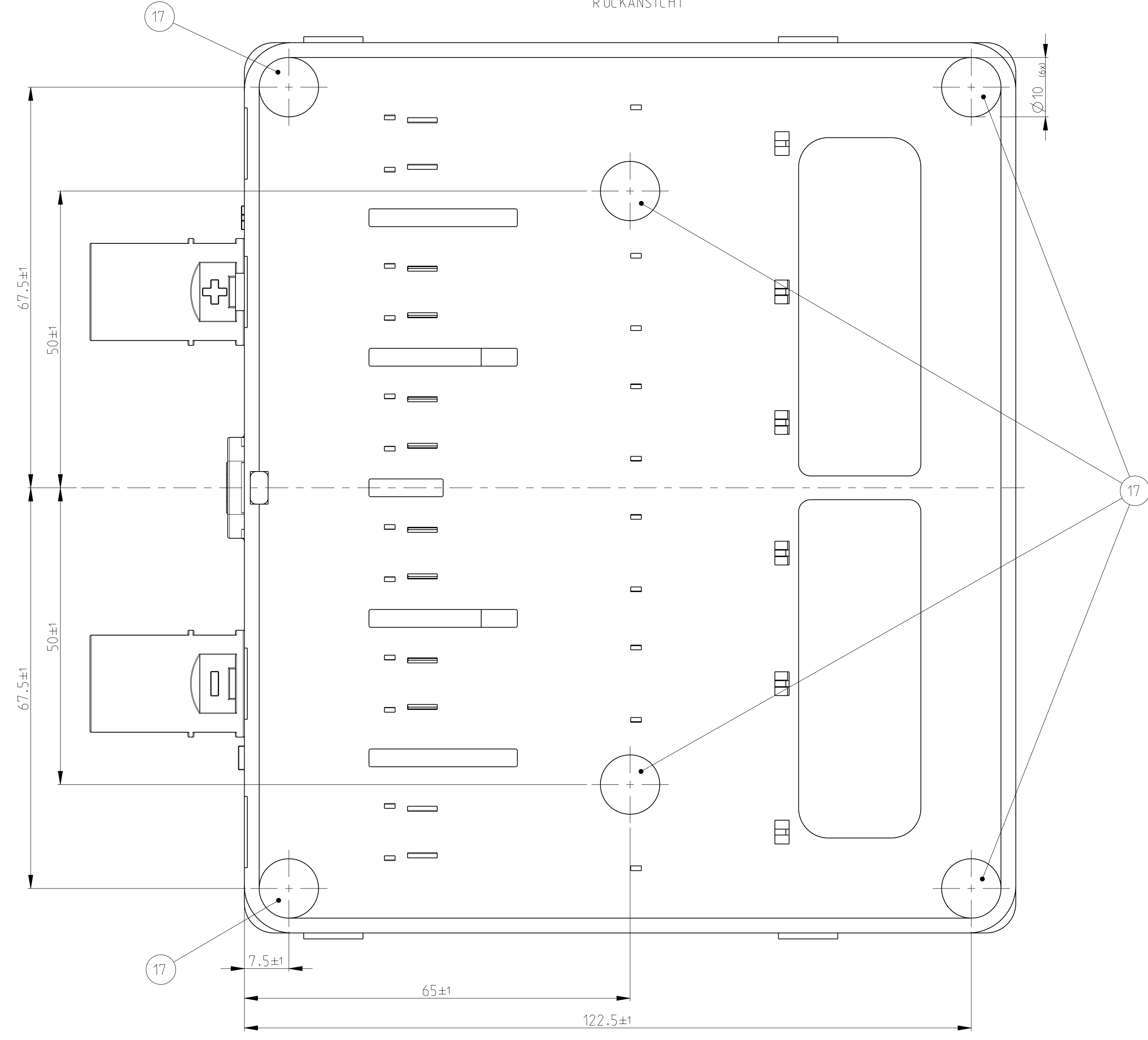

2- -4 AS SHOWN  
2- -4 WIE GEZEICHNET

<small>THIS DRAWING IS UNCLASSIFIED FROM THE PROTECTED INFORMATION...          THIS IS SUBJECT TO EXPORT AND IMPORT RESTRICTIONS...          DATE: 27-FEB-2004          APPROVED FOR EXPORT: 27-FEB-2004          BY: TYCO ELECTRONICS CORPORATION</small>		DWN: E. WERNER CHK: H. SCHNEIDER DATE: 24-FEB-04	Tyco Electronics Tyco Electronics AMP GmbH D - 64625 Bensheim
DIMENSIONS: MASSE/MAßSTÄBE: mm	TOLERANCES, UNLESS OTHERWISE SPECIFIED: ALLGEMEINTOLERANZEN	APVD: G. FELDMAYER DATE: 24-FEB-04 NAME:	NAME: SOLARLOK MODULE BOX, ASSY SOLARLOK MODUL BOX, ASSY
0 PLC ±0.5 1 PLC ±0.5 2 PLC ± 3 PLC ± 4 PLC ± ANGLES/SHOULDER: FINISH/BOHRER/FARBEN	OTHER TOLERANCES: OTHER TOLERANCES: OTHER TOLERANCES:	PRODUCT SPEC: PRODUCT SPEC: PRODUCT SPEC: APPLICATION SPEC: VERARBEITUNGSSPEZ. TITEL/BOHRER	SIZE: A1 CAGE CODE: 00779 DRAWING NO.: 2-1394723-4 RESTRICTED TO: NUR FÜR:
MATERIAL:	FINISH/BOHRER/FARBEN:	WEIGHT: GEWICHT:	CUSTOMER DRAWING /KUNDENZEICHNUNG SCALE: 2:1 MASSSTAB: 2:1 SHEET: 2 OF 2 BLATT VON 2 REV: L1