

Introduction

The YB1921 is a cost-effective system supervisor Integrated Circuit (IC) designed to monitor V_{CC} in digital and mixed signal systems and provide a warning signal when the system power supply is out of working range, and a reset signal to the host processor when necessary. No external components are required.

The reset output is driven active within 20 μ sec of V_{CC} falling through the reset voltage threshold. Reset is maintained active for a minimum of 140msec after V_{CC} rises above the reset threshold. The YB1921 has an active-low RESET output. The output of the YB1921 is guaranteed valid down to $V_{CC}=1V$.

The YB1921 is optimized to reject fast transient glitches on the V_{CC} line. Low supply current of 18 μ A ($V_{CC}=3.3V$) makes these devices suitable for battery powered applications.

Features

- Precision V_{CC} Monitor for 2.8V, 3.0V, 3.3V, and 5.0V Supplies
- 140msec Guaranteed Minimum RESET Output Duration
- RESET Output Guaranteed to $V_{CC}=1.0V$
- Low 18 μ A Supply Current
- V_{CC} Transient Immunity
- Small SOT-23 Package
- No External Components
- Wide Operating Temperature: 0°C to 85°C

Applications

- Computers
- Embedded systems
- Battery powered equipment
- Critical μ P power supply monitoring

Application Diagram

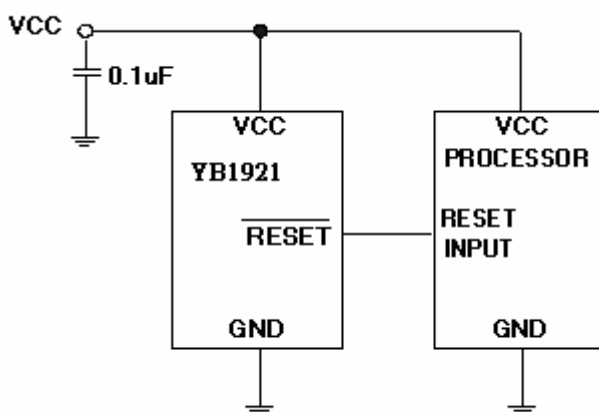

Absolute Maximum Ratings ⁽¹⁾

Parameter	Symbol	Value	Unit
		Value	
Input Voltage	V_{CC}	5.5	V
Output Voltage	RESET	-0.3 to ($V_{CC}+0.3$)	V
Input Current	—	20	mA
Output Current	I_{OUT}	20	mA
Power Dissipation	P_D	Internally Limited ⁽³⁾	—
Output Short Circuit Duration	—	Infinite	—
Thermal Resistance, Junction-to-Ambient	Θ_{JA}	230	°C/W
Operating Temperature Range	T_A	0~85	°C
Lead Temperature (Soldering, 10 sec.)	—	260	°C
Junction Temperature	T_J	0 to+125	°C
Storage Temperature	T_S	-60 to+150	°C

Recommended Operating Conditions ⁽²⁾

Parameter	Symbol	Value			Unit
		Min	Type.	Max	
Power Supply Voltage	V_{CC}	2.0	—	5.5	V
Junction Temperature	T_J	0	—	+125	°C

Electrical Characteristics

V_{CC}=5V for L/M/J; 3.3V for T/S; 3.0V for R, T_A = 25°C, unless otherwise specified.

Parameter	Symbol	Condition	Min	Typ	Max	Unit
Input Voltage	V _{CC}	—	2.0	—	5.5	V
Supply Current	I _{CC}	—	—	18	25	μA
Reset Threshold	V _{TH}	YB1921L-4.63V	4.54	4.63	4.72	V
		YB1921M-4.38V	4.29	4.38	4.47	
		YB1921J-4.00V	3.92	4.00	4.08	
		YB1921T-3.08V	3.02	3.08	3.14	
		YB1921S-2.93V	2.87	2.93	2.99	
		YB1921R-2.63V	2.58	2.63	2.68	
Reset Threshold Temperature Coefficient ⁽⁴⁾	—	—	—	30	—	ppm/°C
V _{CC} to Reset Delay V _{CC} = V _{TH} to (V _{TH} – 100mV)	—	—	—	20	—	μsec
Reset Active Timeout Period	—	—	—	240	—	msec
RESET Output Voltage Low	V _{OL}	I _{SINK} = 3mA	—	—	0.4	V
RESET Output Voltage High	V _{OH}	I _{SOURCE} = 800μA	0.8V _{CC}	—	—	V

Note 1: Exceeding the absolute maximum rating may damage the device.

Note 2: The device is not guaranteed to function outside its operating rating.

Note 3: The maximum allowable power dissipation at any T_A (ambient temperature) is calculated using: P_{D (MAX)} = (T_{J (MAX)} – T_A)/θ_{JA}. Exceeding the maximum allowable power dissipation will result in excessive die temperature, and the regulator will go into thermal shutdown. See “Thermal Consideration” section for details

Note 4: RESET threshold temperature coefficient is the worst case voltage change divided by the total temperature range.

Pin Configuration

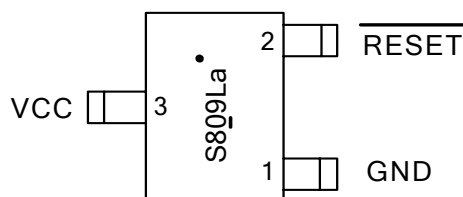

Pin Description

Pin No.	Symbol	Description
1	GND	Ground
2	$\overline{\text{RESET}}$	RESET output remains low while Vcc is below the reset voltage threshold and for 240msec(typ) after Vcc rises above reset threshold
3	Vcc	Supply Voltage (typ.)

Ordering/Marking Information

Package	Reset Vcc threshold (V)	Part Number	Marking	Marking Information
SOT-23	4.63	YB1921LB-F	S8 <u>0</u> 9La •	Starting with 0, a bar underlined 0 is for production year 2006, on top of 9 is for year 2007. And underlined 9 is for year 2008 The next character is marked on top of 8 for 2009, and underlined 8 for 2010. The naming pattern continues with consecutive characters for later years. The last character is the week code. (A-Z: 1-26, a-z: 27-52) A dot on top right corner is for lead-free process.
	4.38	YB1921MB-F	S8 <u>0</u> 9Ma •	
	4.00	YB1921JB-F	S8 <u>0</u> 9Ja •	
	3.08	YB1921TB-F	S8 <u>0</u> 9Ta •	
	2.93	YB1921SB-F	S8 <u>0</u> 9Sa •	
	2.63	YB1921RB-F	S8 <u>0</u> 9Ra •	

Ordering Information

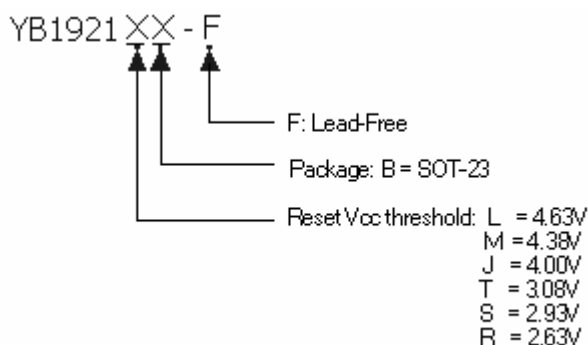

Dimension

Outline Drawing For SOT-23

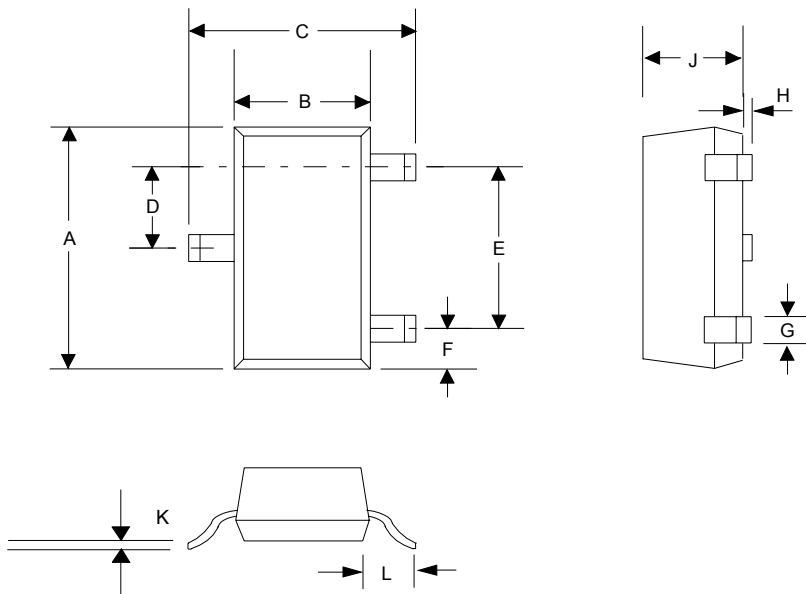

SYMBOL	INCHES		MILLIMETERS	
	MIN	MAX	MIN	MAX
A	0.110	0.120	2.80	3.04
B	0.047	0.055	1.20	1.40
C	0.083	0.104	2.10	2.64
D	0.035	0.040	0.89	1.03
E	0.070	0.080	1.78	2.05
F	0.018	0.024	0.45	0.60
G	0.015	0.020	0.37	0.51
H	0.0005	0.004	0.013	0.10
J	0.034	0.040	0.887	1.02
K	0.003	0.007	0.085	0.18
L	—	0.027	—	0.69