



<http://www.elm-tech.com>

GD25Q16C

DATASHEET

GD25Q16CxIGx 3.3V Uniform Sector Dual and Quad Serial Flash

<http://www.elm-tech.com>

- Content -

Page

1. FEATURES	4
2. GENERAL DESCRIPTION	5
3. MEMORY ORGANIZATION	6
4. DEVICE OPERATION	7
5. DATA PROTECTION	8
6. STATUS REGISTER	10
7. COMMANDS DESCRIPTION	12
7.1. Write Enable (WREN) (06H)	15
7.2. Write Disable (WRDI) (04H)	15
7.3. Read Status Register (RDSR) (05H or 35H)	16
7.4. Write Status Register (WRSR) (01H)	16
7.5. Write Enable for Volatile Status Register (50H)	17
7.6. Read Data Bytes (READ) (03H)	17
7.7. Read Data Bytes at Higher Speed (Fast Read) (0BH)	18
7.8. Dual Output Fast Read (3BH)	18
7.9. Quad Output Fast Read (6BH)	19
7.10. Dual I/O Fast Read (BBH)	19
7.11. Quad I/O Fast Read (EBH)	21
7.12. Quad I/O Word Fast Read (E7H)	22
7.13. Page Program (PP) (02H)	23
7.14. Quad Page Program (32H)	24
7.15. Sector Erase (SE) (20H)	25
7.16. 32KB Block Erase (BE) (52H)	25
7.17. 64KB Block Erase (BE) (D8H)	26
7.18. Chip Erase (CE) (60/C7H)	26
7.19. Deep Power-Down (DP) (B9H)	27
7.20. Release from Deep Power-Down or High Performance Mode and Read Device ID (RDI) (ABH)	28
7.21. Read Manufacture ID/Device ID (REMS) (90H)	29
7.22. Read Identification (RDID) (9FH)	29
7.23. High Performance Mode (HPM) (A3H)	30
7.24. Continuous Read Mode Reset (CRMR) (FFH)	31
7.25. Read Unique ID (4BH)	31
7.26. Program/Erase Suspend (PES) (75H)	32

GD25Q16CxIGx 3.3V Uniform Sector Dual and Quad Serial Flash

<http://www.elm-tech.com>

7.27. Program/Erase Resume (PER) (7AH)	32
7.28. Erase Security Registers (44H)	33
7.29. Program Security Registers (42H)	33
7.30. Read Security Registers (48H)	34
7.31. Enable Reset (66H) and Reset (99H)	35
7.32. Read Serial Flash Discoverable Parameter (5AH)	36
8. ELECTRICAL CHARACTERISTICS	41
8.1. Power-ON timing	41
8.2. Initial delivery state	41
8.3. Data retention and endurance	41
8.4. Absolute maximum ratings	42
8.5. Capacitance measurement conditions	42
8.6. DC characteristics	43
8.7. AC characteristics	43
9. ORDERING INFORMATION	46
10. PACKAGE INFORMATION	47
10.1. Package SOP8 150MIL	47
10.2. Package SOP8 208MIL	48
10.3. Package WSON8 (6×5MM)	49

GD25Q16CxIGx 3.3V Uniform Sector Dual and Quad Serial Flash

<http://www.elm-tech.com>

1. FEATURES

- ◆ 16M-bit Serial Flash
 - 2048K-byte
 - 256 bytes per programmable page
- ◆ Standard, Dual, Quad SPI
 - Standard SPI: SCLK, CS#, SI, SO, WP#, HOLD#
 - Dual SPI: SCLK, CS#, IO0, IO1, WP#, HOLD#
 - Quad SPI: SCLK, CS#, IO0, IO1, IO2, IO3
- ◆ High Speed Clock Frequency
 - 120MHz for fast read with 30PF load
 - Dual I/O Data transfer up to 240Mbits/s
 - Quad I/O Data transfer up to 480Mbits/s
- ◆ Software/Hardware Write Protection
 - Write protect all/portion of memory via software
 - Enable/Disable protection with WP# pin
 - Top or Bottom, Sector or Block selection
- ◆ Cycling endurance
 - Minimum 100,000 Program/Erase Cycles
- ◆ Data retention
 - 20-year data retention typical.
- ◆ Program/Erase Speed
 - Page Program time: 0.6ms typical
 - Sector Erase time: 45ms typical
 - Block Erase time: 0.15/0.25s typical
 - Chip Erase time: 7s typical
- ◆ Flexible Architecture
 - Sector of 4K-byte
 - Block of 32/64K-byte
- ◆ Low Power Consumption
 - 20mA maximum active current
 - 5 μ A maximum power down current
- ◆ Advanced Security Features⁽¹⁾
 - 64-Bit Unique ID for each device
 - 4 \times 256-Byte Security Registers With OTP Locks
 - Discoverable parameters(SFDP) register
- ◆ Single Power Supply Voltage
 - Full voltage range: 2.7~3.6V
- ◆ Package Information
 - SOP8 (150mil)
 - SOP8 (208mil)
 - WSON8 (6 \times 5mm)

Note: (1) Please contact ELM for details.

GD25Q16CxIGx 3.3V Uniform Sector Dual and Quad Serial Flash

<http://www.elm-tech.com>

2. GENERAL DESCRIPTION

The GD25Q16C(16M-bit) Serial flash supports the standard Serial Peripheral Interface (SPI), and supports the Dual/Quad SPI: Serial Clock, Chip Select, Serial Data I/O0 (SI), I/O1 (SO), I/O2 (WP#) and I/O3 (HOLD#). The Dual I/O data is transferred with speed of 240Mbits/s and the Quad I/O & Quad Output data is transferred with speed of 480Mbits/s.

Connection Diagram

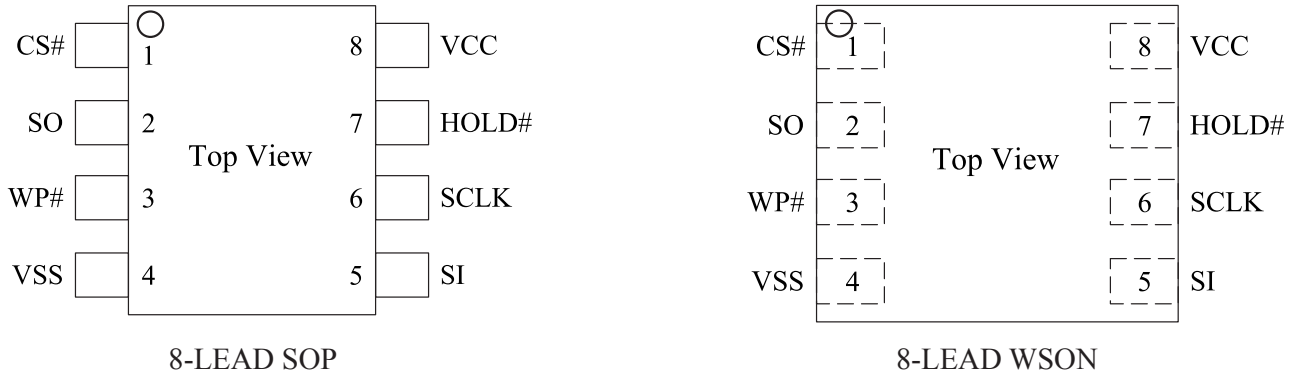

Pin Description

Pin Name	I / O	Description
CS#	I	Chip Select Input
SO (IO1)	I/O	Data Output (Data Input Output 1)
WP# (IO2)	I/O	Write Protect Input (Data Input Output 2)
VSS		Ground
SI (IO0)	I/O	Data Input (Data Input Output 0)
SCLK	I	Serial Clock Input
HOLD# (IO3)	I/O	Hold Input (Data Input Output 3)
VCC		Power Supply

Block Diagram

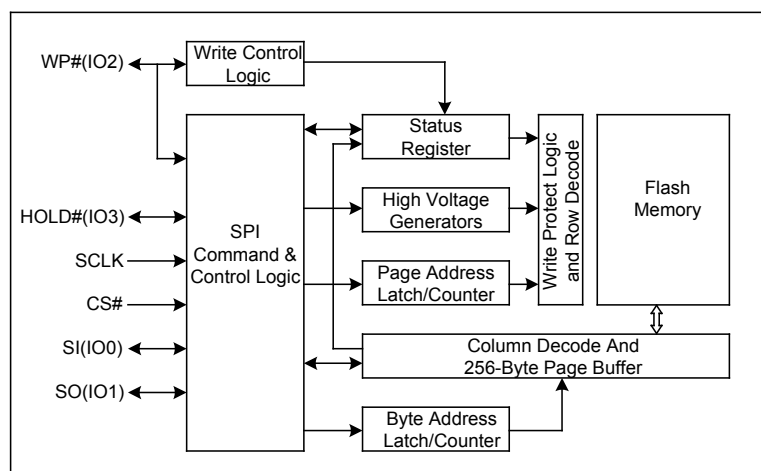

GD25Q16CxIGx 3.3V Uniform Sector Dual and Quad Serial Flash

<http://www.elm-tech.com>

3. MEMORY ORGANIZATION

GD25Q16C

Each device has	Each block has	Each sector has	Each page has	
2M	64/32K	4K	256	bytes
8K	256/128	16	-	pages
512	16/8	-	-	sectors
32/64	-	-	-	blocks

Uniform Block Sector Architecture

GD25Q16C 64K Bytes Block Sector Architecture

Block	Sector	Address range	
31	511	1FF000H	1FFFFFFH
	----	----	----
	496	1F0000H	1F0FFFFH
30	495	1EF000H	1EFFFFFFH
	----	----	----
	480	1E0000H	1E0FFFFH
----	----	----	----
	----	----	----
	----	----	----
----	----	----	----
	----	----	----
	----	----	----
2	47	02F000H	02FFFFFFH
	----	----	----
	32	020000H	020FFFFH
1	31	01F000H	01FFFFFFH
	----	----	----
	16	010000H	010FFFFH
0	15	00F000H	00FFFFFFH
	----	----	----
	0	000000H	000FFFFH

GD25Q16CxIGx 3.3V Uniform Sector Dual and Quad Serial Flash

<http://www.elm-tech.com>

4. DEVICE OPERATION

SPI Mode

Standard SPI

The GD25Q16C feature a serial peripheral interface on 4 signals bus: Serial Clock (SCLK), Chip Select (CS#), Serial Data Input (SI) and Serial Data Output (SO). Both SPI bus mode 0 and 3 are supported. Input data is latched on the rising edge of SCLK and data shifts out on the falling edge of SCLK.

Dual SPI

The GD25Q16C supports Dual SPI operation when using the “Dual Output Fast Read” and “Dual I/O Fast Read”(3BH and BBH) commands. These commands allow data to be transferred to or from the device at two times the rate of the standard SPI. When using the Dual SPI command the SI and SO pins become bidirectional I/O pins: IO0 and IO1.

Quad SPI

The GD25Q16C supports Quad SPI operation when using the “Quad Output Fast Read”(6BH), “Quad I/O Fast Read”(EBH), “Quad I/O Word Fast Read”(E7H) and “Quad Page Program” (32H) commands. These commands allow data to be transferred to or from the device at four times the rate of the standard SPI. When using the Quad SPI command the SI and SO pins become bidirectional I/O pins: IO0 and IO1, and WP# and HOLD# pins become IO2 and IO3. Quad SPI commands require the non-volatile Quad Enable bit (QE) in Status Register to be set.

Hold

The HOLD# function is only available when QE=0, If QE=1, The HOLD# function is disabled, the pin acts as dedicated data I/O pin.

The HOLD# signal goes low to stop any serial communications with the device, but doesn't stop the operation of write status register, programming, or erasing in progress.

The operation of HOLD, need CS# keep low, and starts on falling edge of the HOLD# signal, with SCLK signal being low (if SCLK is not being low, HOLD operation will not start until SCLK being low). The HOLD condition ends on rising edge of HOLD# signal with SCLK being low (If SCLK is not being low, HOLD operation will not end until SCLK being low).

The SO is high impedance, both SI and SCLK don't care during the HOLD operation, if CS# drives high during HOLD operation, it will reset the internal logic of the device. To re-start communication with chip, the HOLD# must be at high and then CS# must be at low.

Figure 1. Hold Condition

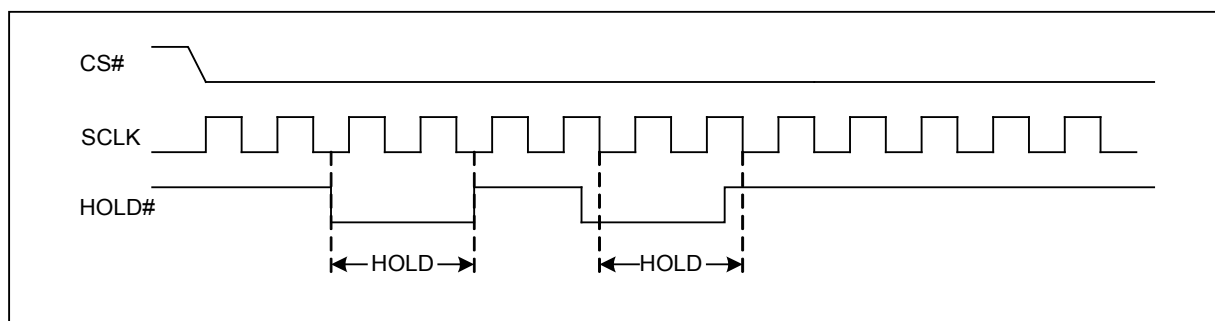

GD25Q16CxIGx 3.3V Uniform Sector Dual and Quad Serial Flash

<http://www.elm-tech.com>

5. DATA PROTECTION

The GD25Q16C provides the following data protection methods:

- ◆ Write Enable (WREN) command: The WREN command is set the Write Enable Latch bit (WEL). The WEL bit will return to reset by the following situation:
 - Power-Up
 - Write Disable (WRDI)
 - Write Status Register (WRSR)
 - Page Program (PP)
 - Sector Erase (SE) / Block Erase (BE) / Chip Erase (CE)
- ◆ Software Protection Mode: The Block Protect (BP4, BP3, BP2, BP1 and BP0) bits define the section of the memory array that can be read but not change.
- ◆ Hardware Protection Mode: WP# going low to protected the BP0~BP4 bits and SRP0~1 bits.
- ◆ Deep Power-Down Mode: In Deep Power-Down Mode, all commands are ignored except the Release from Deep Power-Down Mode command.

Table1.0 GD25Q16C Protected area size (CMP=0)

Status Register Content					Memory Content			
BP4	BP3	BP2	BP1	BP0	Blocks	Addresses	Density	Portion
×	×	0	0	0	NONE	NONE	NONE	NONE
0	0	0	0	1	31	1F0000H-1FFFFFFH	64KB	Upper 1/32
0	0	0	1	0	30 to 31	1E0000H-1FFFFFFH	128KB	Upper 1/16
0	0	0	1	1	28 to 31	1C0000H-1FFFFFFH	256KB	Upper 1/8
0	0	1	0	0	24 to 31	180000H-1FFFFFFH	512KB	Upper 1/4
0	0	1	0	1	16 to 31	100000H-1FFFFFFH	1M	Upper 1/2
0	1	0	0	1	0	000000H-00FFFFH	64KB	Lower 1/32
0	1	0	1	0	0 to 1	000000H-01FFFFH	128KB	Lower 1/16
0	1	0	1	1	0 to 3	000000H-03FFFFH	256KB	Lower 1/8
0	1	1	0	0	0 to 7	000000H-07FFFFH	512KB	Lower 1/4
0	1	1	0	1	0 to 15	000000H-0FFFFFFH	1MB	Lower 1/2
×	×	1	1	×	0 to 31	000000H-1FFFFFFH	2MB	ALL
1	0	0	0	1	31	1FF000H-1FFFFFFH	4KB	Top Block
1	0	0	1	0	31	1FE000H-1FFFFFFH	8KB	Top Block
1	0	0	1	1	31	1FC000H-1FFFFFFH	16KB	Top Block
1	0	1	0	×	31	1F8000H-1FFFFFFH	32KB	Top Block
1	1	0	0	1	0	000000H-000FFFH	4KB	Bottom Block
1	1	0	1	0	0	000000H-001FFFH	8KB	Bottom Block
1	1	0	1	1	0	000000H-003FFFH	16KB	Bottom Block
1	1	1	0	×	0	000000H-007FFFH	32KB	Bottom Block

GD25Q16CxIGx 3.3V Uniform Sector Dual and Quad Serial Flash

<http://www.elm-tech.com>

Table1.1. GD25Q16C Protected area size (CMP=1)

Status Register Content					Memory Content			
BP4	BP3	BP2	BP1	BP0	Blocks	Addresses	Density	Portion
×	×	0	0	0	0 to 31	000000H-1FFFFFFH	2M	ALL
0	0	0	0	1	0 to 30	000000H-1EFFFFFFH	1984KB	Lower 31/32
0	0	0	1	0	0 to 29	000000H-1DFFFFFFH	1920KB	Lower 15/16
0	0	0	1	1	0 to 27	000000H-1BFFFFFFH	1792KB	Lower 7/8
0	0	1	0	0	0 to 23	000000H-17FFFFFFH	1536KB	Lower 3/4
0	0	1	0	1	0 to 15	000000H-0FFFFFFH	1M	Lower 1/2
0	1	0	0	1	1 to 31	010000H-1FFFFFFH	1984KB	Upper 31/32
0	1	0	1	0	2 to 31	020000H-1FFFFFFH	1920KB	Upper 15/16
0	1	0	1	1	4 to 31	040000H-1FFFFFFH	1792KB	Upper 7/8
0	1	1	0	0	8 to 31	080000H-1FFFFFFH	1536KB	Upper 3/4
0	1	1	0	1	16 to 31	100000H-1FFFFFFH	1M	Upper 1/2
×	×	1	1	×	NONE	NONE	NONE	NONE
1	0	0	0	1	0 to 31	000000H-1FEFFFFH	2044KB	Lower 511/512
1	0	0	1	0	0 to 31	000000H-1FDFFFFH	2040KB	Lower 255/256
1	0	0	1	1	0 to 31	000000H-1FBFFFFH	2032KB	Lower 127/128
1	0	1	0	×	0 to 31	000000H-1F7FFFFH	2016KB	Lower 63/64
1	1	0	0	1	0 to 31	001000H-1FFFFFFH	2044KB	Upper 511/512
1	1	0	1	0	0 to 31	002000H-1FFFFFFH	2040KB	Upper 255/256
1	1	0	1	1	0 to 31	004000H-1FFFFFFH	2032KB	Upper 127/128
1	1	1	0	×	0 to 31	008000H-1FFFFFFH	2016KB	Upper 63/64

GD25Q16CxIGx 3.3V Uniform Sector Dual and Quad Serial Flash

<http://www.elm-tech.com>

6. STATUS REGISTER

S15	S14	S13	S12	S11	S10	S9	S8
SUS	CMP	HPM	Reserved	Reserved	LB	QE	SRP1
S7	S6	S5	S4	S3	S2	S1	S0
SRP0	BP4	BP3	BP2	BP1	BP0	WEL	WIP

The status and control bits of the Status Register are as follows:

WIP bit.

The Write in Progress (WIP) bit indicates whether the memory is busy in program/erase/write status register progress. When WIP bit sets to 1, means the device is busy in program/erase/write status register progress, when WIP bit sets 0, means the device is not in program/erase/write status register progress.

WEL bit.

The Write Enable Latch (WEL) bit indicates the status of the internal Write Enable Latch. When set to 1 the internal Write Enable Latch is set, when set to 0 the internal Write Enable Latch is reset and no Write Status Register, Program or Erase command is accepted.

BP4, BP3, BP2, BP1, BP0 bits.

The Block Protect (BP4, BP3, BP2, BP1 and BP0) bits are non-volatile. They define the size of the area to be software protected against Program and Erase commands. These bits are written with the Write Status Register (WRSR) command. When the Block Protect (BP4, BP3, BP2, BP1 and BP0) bits are set to 1, the relevant memory area (as defined in Table1). becomes protected against Page Program (PP), Sector Erase (SE) and Block Erase (BE) commands. The Block Protect (BP4, BP3, BP2, BP1 and BP0) bits can be written provided that the Hardware Protected mode has not been set. The Chip Erase (CE) command is executed, only if the Block Protect (BP2, BP1 and BP0) bits are 0 and CMP=0.

SRP1, SRP0 bits.

The Status Register Protect (SRP1 and SRP0) bits are non-volatile Read/Write bits in the status register. The SRP bits control the method of write protection: software protection, hardware protection, power supply lock-down or one time programmable protection.

SRP1	SRP0	#WP	Status Register	Description
0	0	×	Software Protected	The Status Register can be written to after a Write Enable command, WEL=1.(Default)
0	1	0	Hardware Protected	WP#=0, the Status Register locked and can not be written to.
0	1	1	Hardware Unprotected	WP#=1, the Status Register is unlocked and can be written to after a Write Enable command, WEL=1.
1	0	×	Power Supply Lock-Down(1)(2)	Status Register is protected and can not be written to again until the next Power-Down, Power-Up cycle.
1	1	×	One Time Program(2)	Status Register is permanently protected and can not be written to.

NOTE:

- (1). When SRP1, SRP0= (1, 0), a Power-Down, Power-Up cycle will change SRP1, SRP0 to (0, 0) state.
- (2). This feature is available on special order. (GD25Q16CxxSx)Please contact ELM for details.

GD25Q16CxIGx 3.3V Uniform Sector Dual and Quad Serial Flash

<http://www.elm-tech.com>

QE bit.

The Quad Enable (QE) bit is a non-volatile Read/Write bit in the Status Register that allows Quad operation. When the QE bit is set to 0 (Default) the WP# pin and HOLD# pin are enable. When the QE pin is set to 1, the Quad IO2 and IO3 pins are enabled. (The QE bit should never be set to 1 during standard SPI or Dual SPI operation if the WP# or HOLD# pins are tied directly to the power supply or ground).

LB bit.

The LB bit is a non-volatile One Time Program (OTP) bit in Status Register (S10) that provide the write protect control and status to the Security Registers. The default state of LB is 0, the security registers are unlocked. LB can be set to 1 individually using the Write Register instruction. LB is One Time Programmable, once it's set to 1, the Security Registers will become read-only permanently.

CMP bit.

The CMP bit is a non-volatile Read/Write bit in the Status Register (S14). It is used in conjunction the BP4-BP0 bits to provide more flexibility for the array protection. Please see the Status registers Memory Protection table for details. The default setting is CMP=0.

HPF bit.

The High Performance Flag (HPF) bit indicates the status of High Performance Mode (HPM). When HPF bit sets to 1, it means the device is in High Performance Mode, when HPF bit sets 0 (default), it means the device is not in High Performance Mode.

SUS bits.

The SUS bit is a read only bit in the status register (S15) that is set to 1 after executing an Erase/Program Suspend (75H) command. The SUS bit is cleared to 0 by Erase/Program Resume (7AH) command as well as a power-down, power-up cycle.

GD25Q16CxIGx 3.3V Uniform Sector Dual and Quad Serial Flash

<http://www.elm-tech.com>

7. COMMANDS DESCRIPTION

All commands, addresses and data are shifted in and out of the device, beginning with the most significant bit on the first rising edge of SCLK after CS# is driven low. Then, the one-byte command code must be shifted in to the device, most significant bit first on SI, each bit being latched on the rising edges of SCLK.

See Table2, every command sequence starts with a one-byte command code. Depending on the command, this might be followed by address bytes, or by data bytes, or by both or none. CS# must be driven high after the last bit of the command sequence has been shifted in. For the commands of Read, Fast Read, Read Status Register or Release from Deep Power-Down, and Read Device ID, the shifted-in command sequence is followed by a data-out sequence. CS# can be driven high after any bit of the data-out sequence is being shifted out.

For the commands of Page Program, Sector Erase, Block Erase, Chip Erase, Write Status Register, Write Enable, Write Disable or Deep Power-Down command, CS# must be driven high exactly at a byte boundary, otherwise the command is rejected, and is not executed. That means CS# must be driven high when the number of clock pulses after CS# being driven low is an exact multiple of eight. For Page Program, if CS# is driven high at any time the input byte is not a full byte, nothing will happen and WEL will not be reset.

Table2. Commands (Standard/Dual/Quad SPI)

Command Name	Byte 1	Byte 2	Byte 3	Byte 4	Byte 5	Byte 6	n-Bytes
Write Enable	06H						
Write Disable	04H						
Volatile SR Write Enable	50H						
Read Status Register	05H	(S7-S0)					(continuous)
Read Status Register-1	35H	(S15-S8)					(continuous)
Write Status Register	01H	(S7-S0)	(S15-S8)				
Read Data	03H	A23-A16	A15-A8	A7-A0	(D7-D0)	(Next byte)	(continuous)
Fast Read	0BH	A23-A16	A15-A8	A7-A0	dummy	(D7-D0)	(continuous)
Dual Output Fast Read	3BH	A23-A16	A15-A8	A7-A0	dummy	D7-D0 ⁽¹⁾	(continuous)
Dual I/O Fast Read	BBH	A23-A8 ⁽²⁾	A7-A0 M7-M0 ⁽²⁾	(D7-D0) ⁽¹⁾			(continuous)
Quad Output Fast Read	6BH	A23-A16	A15-A8	A7-A0	dummy	(D7-D0) ⁽³⁾	(continuous)
Quad I/O Fast Read	EBH	A23-A0 M7-M0 ⁽⁴⁾	dummy ⁽⁵⁾	(D7-D0) ⁽³⁾			(continuous)
Quad I/O Word Fast Read ⁽⁷⁾	E7H	A23-A0 M7-M0 ⁽⁴⁾	dummy ⁽⁶⁾	(D7-D0) ⁽³⁾			(continuous)
Continuous Read Mode Reset	FFH						
Page Program	02H	A23-A16	A15-A8	A7-A0	D7-D0	Next byte	
Quad Page Program	32H	A23-A16	A15-A8	A7-A0	D7-D0 ⁽³⁾		
Sector Erase	20H	A23-A16	A15-A8	A7-A0			
Block Erase (32K)	52H	A23-A16	A15-A8	A7-A0			
Block Erase (64K)	D8H	A23-A16	A15-A8	A7-A0			
Chip Erase	C7/60H						
Enable Reset	66H						
Reset	99H						
Program/Erase Suspend	75H						
Program/Erase Resume	7AH						

GD25Q16CxIGx 3.3V Uniform Sector Dual and Quad Serial Flash

<http://www.elm-tech.com>

Command Name	Byte 1	Byte 2	Byte 3	Byte 4	Byte 5	Byte 6	n-Bytes
Deep Power-Down	B9H						
Release From Deep Power-Down, And Read Device ID	ABH	dummy	dummy	dummy	(DID7-DID0)		(continuous)
Release From Deep Power-Down	ABH						
Manufacturer/Device ID	90H	dummy	dummy	00H	(MID7-MID0)	(DID7-DID0)	(continuous)
Read Unique ID	4BH	dummy	dummy	dummy	dummy	(UID127-D0)	
High Performance Mode	A3H	dummy	dummy	dummy			
Read Serial Flash Discoverable Parameter	5AH	A23-A16	A15-A8	A7-A0	dummy	(D7-D0)	(continuous)
Read Identification	9FH	(MID7-M0)	(JDID15-JDID8)	(JDID7-JDID0)			(continuous)
Erase Security Registers ⁽⁸⁾	44H	A23-A16	A15-A8	A7-A0			
Program Security Registers ⁽⁸⁾	42H	A23-A16	A15-A8	A7-A0	(D7-D0)	(D7-D0)	
Read Security Registers ⁽⁸⁾	48H	A23-A16	A15-A8	A7-A0	dummy	(D7-D0)	

NOTE:

(1) Dual Output data

IO0 = (D6, D4, D2, D0)

IO1 = (D7, D5, D3, D1)

(2) Dual Input Address

IO0 = A22, A20, A18, A16, A14, A12, A10, A8 A6, A4, A2, A0, M6, M4, M2, M0

IO1 = A23, A21, A19, A17, A15, A13, A11, A9 A7, A5, A3, A1, M7, M5, M3, M1

(3) Quad Output Data

IO0 = (D4, D0,)

IO1 = (D5, D1,)

IO2 = (D6, D2,)

IO3 = (D7, D3,)

(4) Quad Input Address

IO0 = A20, A16, A12, A8, A4, A0, M4, M0

IO1 = A21, A17, A13, A9, A5, A1, M5, M1

IO2 = A22, A18, A14, A10, A6, A2, M6, M2

IO3 = A23, A19, A15, A11, A7, A3, M7, M3

(5) Fast Read Quad I/O Data

IO0 = (x, x, x, x, D4, D0,...)

GD25Q16CxIGx 3.3V Uniform Sector Dual and Quad Serial Flash

<http://www.elm-tech.com>

IO1 = (x, x, x, x, D5, D1,...)

IO2 = (x, x, x, x, D6, D2,...)

IO3 = (x, x, x, x, D7, D3,...)

(6) Fast Word Read Quad I/O Data

IO0 = (x, x, D4, D0,...)

IO1 = (x, x, D5, D1,...)

IO2 = (x, x, D6, D2,...)

IO3 = (x, x, D7, D3,...)

(7) Fast Word Read Quad I/O Data: the lowest address bit must be 0.

(8) Security Registers Address:

Security Register0: A23-A16=00H, A15-A8=00H, A7-A0=Byte Address;

Security Register1: A23-A16=00H, A15-A8=01H, A7-A0=Byte Address;

Security Register2: A23-A16=00H, A15-A8=02H, A7-A0=Byte Address;

Security Register3: A23-A16=00H, A15-A8=03H, A7-A0=Byte Address.

(9) Address, Continuous Read Mode bits, Dummy bits, Manufacture ID and Device ID

IO0 = (A20, A16, A12, A8, A4, A0, M4, M0, x, x, x, x, MID4, MID0, DID4, DID0, ...)

IO1 = (A21, A17, A13, A9, A5, A1, M5, M1, x, x, x, x, MID5, MID1, DID5, DID1, ...)

IO2 = (A22, A18, A14, A10, A6, A2, M6, M2, x, x, x, x, MID6, MID2, DID6, DID2, ...)

IO3 = (A23, A19, A15, A11, A7, A3, M7, M3, x, x, x, x, MID7, MID3, DID7, DID3, ...)

Table Of ID Definitions:

GD25Q16C

Operation Code	MID7-MID0	ID15-ID8	ID7-ID0
9FH	C8	40	15
90H	C8		14
ABH			14

GD25Q16CxIGx 3.3V Uniform Sector Dual and Quad Serial Flash

<http://www.elm-tech.com>

7.1. Write Enable (WREN)(06H)

The Write Enable (WREN) command is for setting the Write Enable Latch (WEL) bit. The Write Enable Latch (WEL) bit must be set prior to every Page Program (PP), Sector Erase (SE), Block Erase (BE), Chip Erase (CE), Write Status Register (WRSR) and Erase/Program Security Register command. The Write Enable (WREN) command sequence: CS# goes low → sending the Write Enable command → CS# goes high.

Figure 2. Write Enable Sequence Diagram

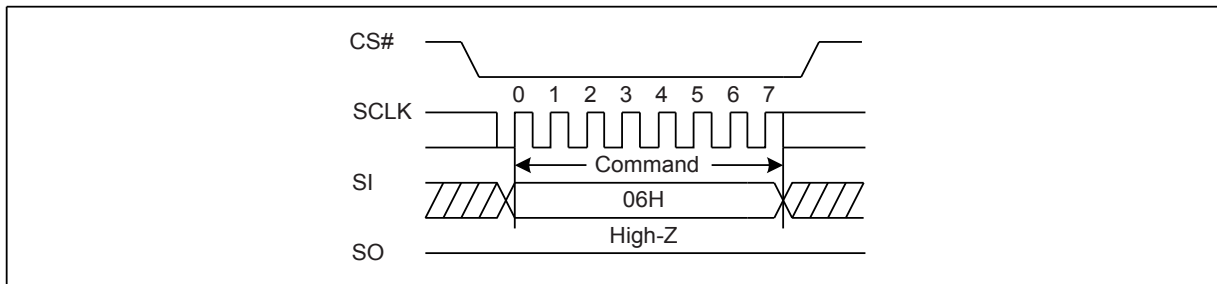

7.2. Write Disable (WRDI) (04H)

The Write Disable command is for resetting the Write Enable Latch (WEL) bit. The Write Disable command sequence: CS# goes low → Sending the Write Disable command → CS# goes high. The WEL bit is reset by following condition: Power-up and upon completion of the Write Status Register, Page Program, Sector Erase, Block Erase, Chip Erase, Erase/Program Security Register and Reset commands.

Figure 3. Write Disable Sequence Diagram

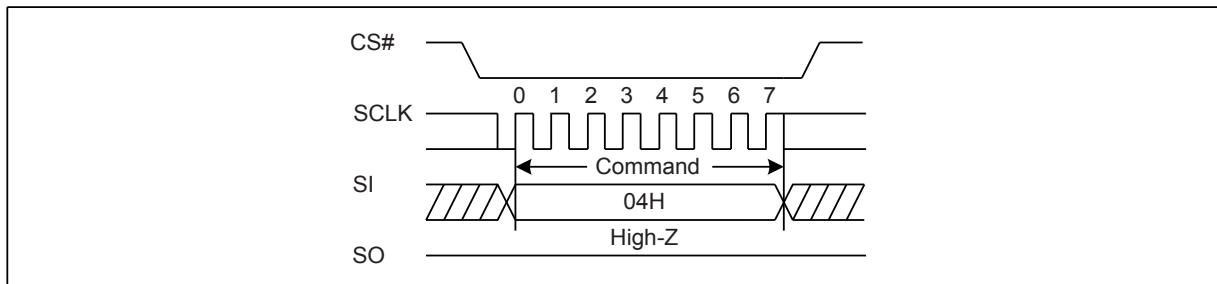

GD25Q16CxIGx 3.3V Uniform Sector Dual and Quad Serial Flash

7.3. Read Status Register (RDSR) (05H or 35H)

The Read Status Register (RDSR) command is for reading the Status Register. The Status Register may be read at any time, even while a Program, Erase or Write Status Register cycle is in progress. When one of these cycles is in progress, it is recommended to check the Write In Progress (WIP) bit before sending a new command to the device. It is also possible to read the Status Register continuously. For command code “05H”, the SO will output Status Register bits S7~S0. The command code “35H”, the SO will output Status Register bits S15~S8.

Figure 4. Read Status Register Sequence Diagram

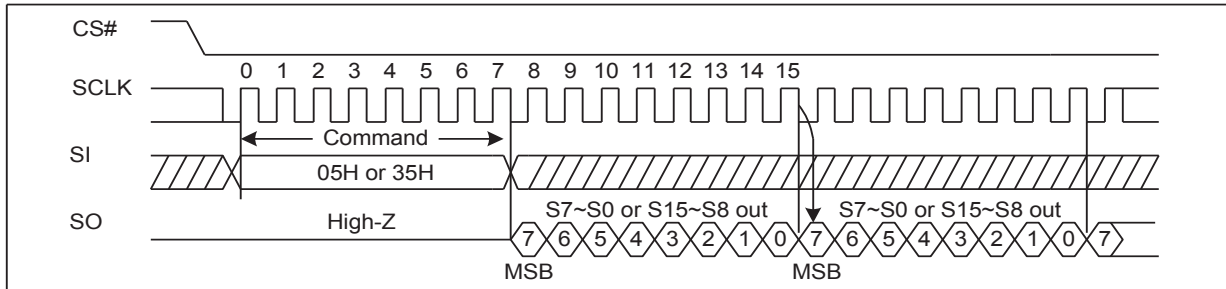

7.4. Write Status Register (WRSR) (01H)

The Write Status Register (WRSR) command allows new values to be written to the Status Register. Before it can be accepted, a Write Enable (WREN) command must previously have been executed. After the Write Enable (WREN) command has been decoded and executed, the device sets the Write Enable Latch (WEL).

The Write Status Register (WRSR) command has no effect on S15, S1 and S0 of the Status Register. CS# must be driven high after the eighth or sixteen bit of the data byte has been latched in. If not, the Write Status Register (WRSR) command is not executed. If CS# is driven high after eighth bit of the data byte, the CMP and QE bit will be cleared to 0. As soon as CS# is driven high, the self-timed Write Status Register cycle (whose duration is t_w) is initiated. While the Write Status Register cycle is in progress, the Status Register may still be read to check the value of the Write In Progress (WIP) bit. The Write In Progress (WIP) bit is 1 during the self-timed Write Status Register cycle, and is 0 when it is completed. When the cycle is completed, the Write Enable Latch (WEL) is reset.

The Write Status Register (WRSR) command allows the user to change the values of the Block Protect (BP4, BP3, BP2, BP1 and BP0) bits, to define the size of the area that is to be treated as read-only, as defined in Table1. The Write Status Register (WRSR) command also allows the user to set or reset the Status Register Protect (SRP) bit in accordance with the Write Protect (WP#) signal. The Status Register Protect (SRP) bit and Write Protect (WP#) signal allow the device to be put in the Hardware Protected Mode. The Write Status Register (WRSR) command is not executed once the Hardware Protected Mode is entered.

Figure 5. Write Status Register Sequence Diagram

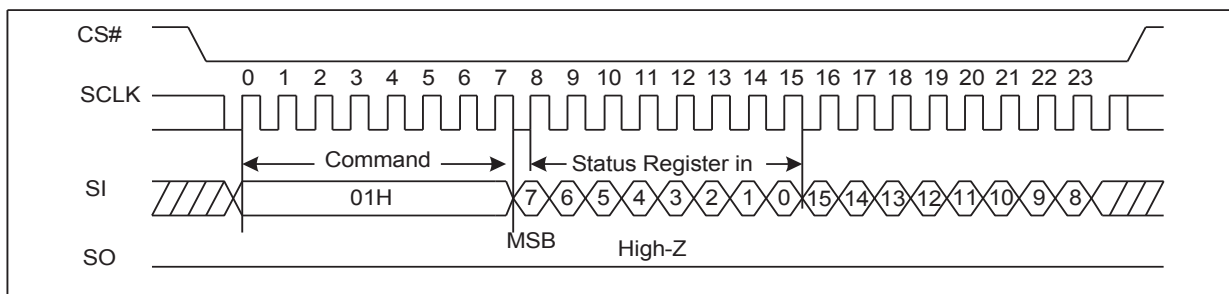

GD25Q16CxIGx 3.3V Uniform Sector Dual and Quad Serial Flash

7.5. Write Enable for Volatile Status Register (50H)

The non-volatile Status Register bits can also be written to as volatile bits. This gives more flexibility to change the system configuration and memory protection schemes quickly without waiting for the typical non-volatile bit write cycles or affecting the endurance of the Status Register non-volatile bits. The Write Enable for Volatile Status Register command must be issued prior to a Write Status Register command. The Write Enable for Volatile Status Register command will not set the Write Enable Latch bit, it is only valid for the Write Status Register command to change the volatile Status Register bit values.

Figure 6. Write Enable for Volatile Status Register Sequence Diagram

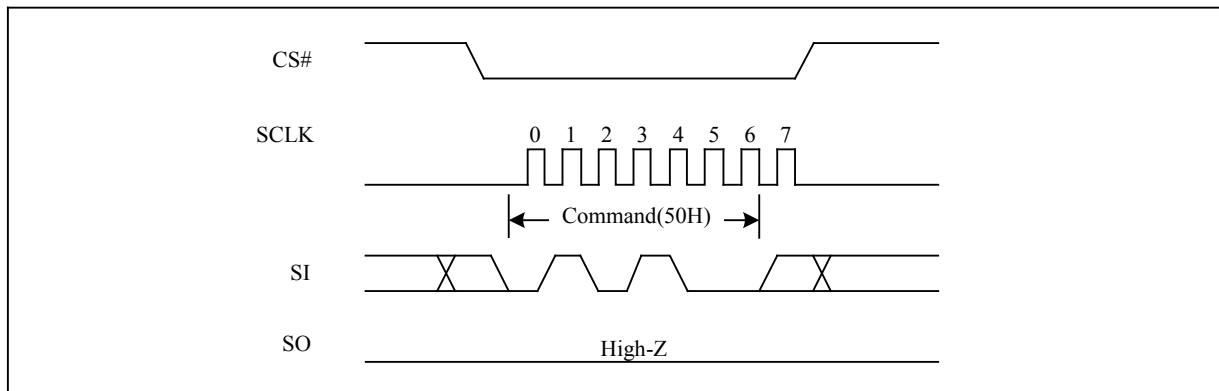

7.6. Read Data Bytes (READ) (03H)

The Read Data Bytes (READ) command is followed by a 3-byte address (A23-A0), each bit being latched-in during the rising edge of SCLK. Then the memory content, at that address, is shifted out on SO, each bit being shifted out, at a Max frequency f_R , during the falling edge of SCLK. The first byte addressed can be at any location. The address is automatically incremented to the next higher address after each byte of data is shifted out. The whole memory can, therefore, be read with a single Read Data Bytes (READ) command. Any Read Data Bytes (READ) command, while an Erase, Program or Write cycle is in progress, is rejected without having any effects on the cycle that is in progress.

Figure 7. Read Data Bytes Sequence Diagram

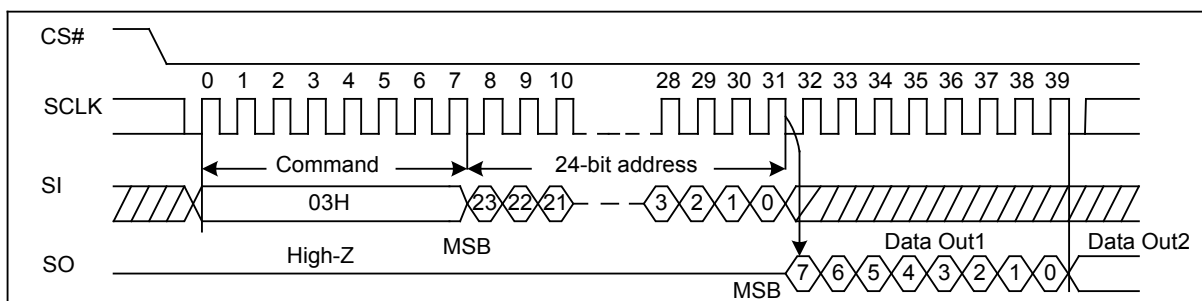

GD25Q16CxIGx 3.3V Uniform Sector Dual and Quad Serial Flash

7.7. Read Data Bytes at Higher Speed (Fast Read) (0BH)

The Read Data Bytes at Higher Speed (Fast Read) command is for quickly reading data out. It is followed by a 3-byte address (A23-A0) and a dummy byte, each bit being latched-in during the rising edge of SCLK. Then the memory content, at that address, is shifted out on SO, each bit being shifted out, at a Max frequency f_c , during the falling edge of SCLK. The first byte addressed can be at any location. The address is automatically incremented to the next higher address after each byte of data is shifted out.

Figure 8. Read Data Bytes at Higher Speed Sequence Diagram

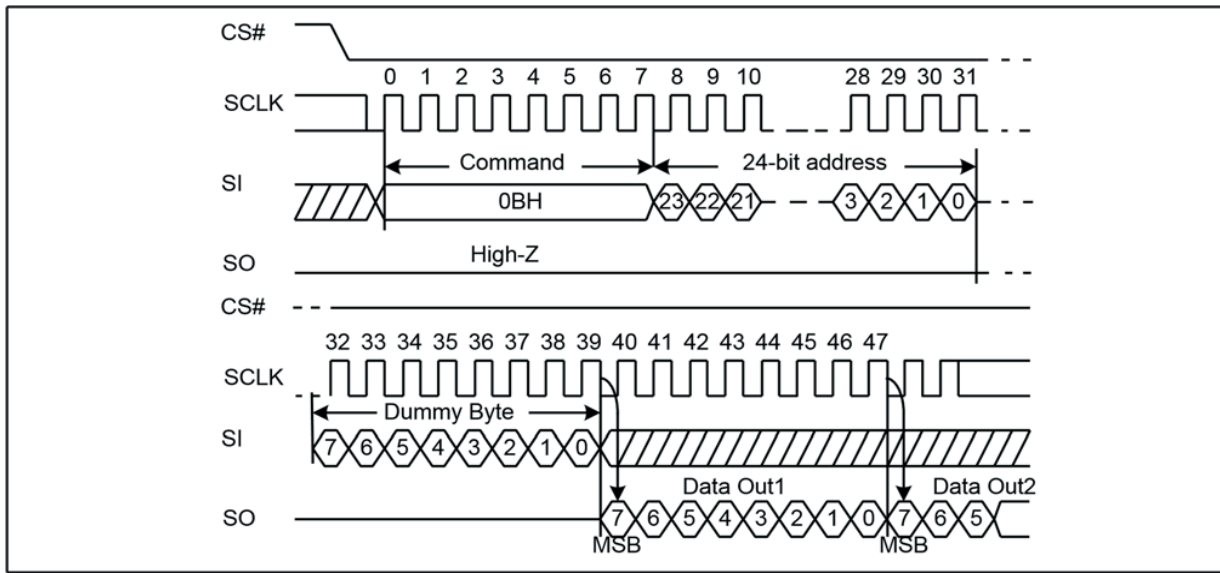

7.8. Dual Output Fast Read (3BH)

The Dual Output Fast Read command is followed by 3-byte address (A23-A0) and a dummy byte, each bit being latched in during the rising edge of SCLK, then the memory contents are shifted out 2-bit per clock cycle from SI and SO. The command sequence is shown in followed Figure9. The first byte addressed can be at any location. The address is automatically incremented to the next higher address after each byte of data is shifted out.

Figure 9. Dual Output Fast Read Sequence Diagram

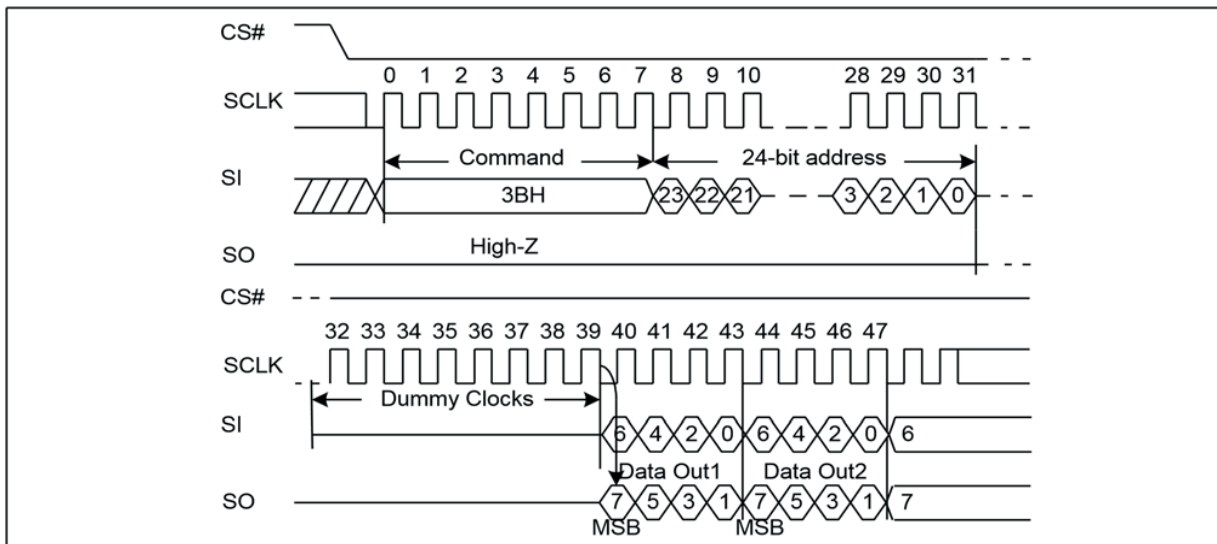

GD25Q16CxIGx 3.3V Uniform Sector Dual and Quad Serial Flash

7.9. Quad Output Fast Read (6BH)

The Quad Output Fast Read command is followed by 3-byte address (A23-A0) and a dummy byte, each bit being latched in during the rising edge of SCLK, then the memory contents are shifted out 4-bit per clock cycle from IO3, IO2, IO1 and IO0. The command sequence is shown in followed Figure10. The first byte addressed can be at any location. The address is automatically incremented to the next higher address after each byte of data is shifted out.

Figure 10. Quad Output Fast Read Sequence Diagram

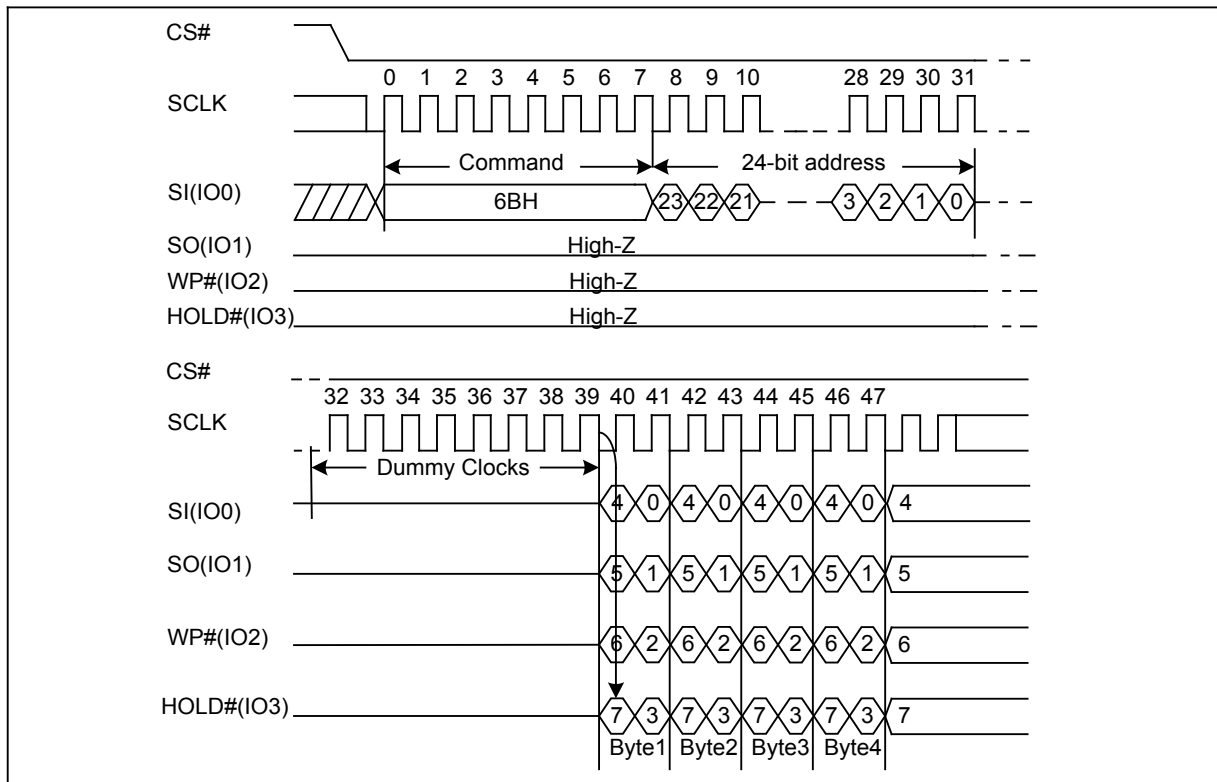

7.10. Dual I/O Fast Read (BBH)

The Dual I/O Fast Read command is similar to the Dual Output Fast Read command but with the capability to input the 3-byte address (A23-0) and a “Continuous Read Mode” byte 2-bit per clock by SI and SO, each bit being latched in during the rising edge of SCLK, then the memory contents are shifted out 2-bit per clock cycle from SI and SO. The command sequence is shown in followed Figure11. The first byte addressed can be at any location. The address is automatically incremented to the next higher address after each byte of data is shifted out.

Dual I/O Fast Read with “Continuous Read Mode”

The Dual I/O Fast Read command can further reduce command overhead through setting the “Continuous Read Mode” bits (M7-0) after the input 3-byte address (A23-A0). If the “Continuous Read Mode” bits (M7-0) = AXH, then the next Dual I/O Fast Read command (after CS# is raised and then lowered) does not require the BBH command code. The command sequence is shown in followed Figure12. If the “Continuous Read Mode” bits (M7-0) are any value other than AXH, the next command requires the first BBH command code, thus returning to normal operation. A “Continuous Read Mode” Reset command can be used to reset (M7-0) before issuing normal command.

GD25Q16CxIGx 3.3V Uniform Sector Dual and Quad Serial Flash

<http://www.elm-tech.com>

Figure 11. Dual I/O Fast Read Sequence Diagram (M7-0 = 0XH or not AXH)

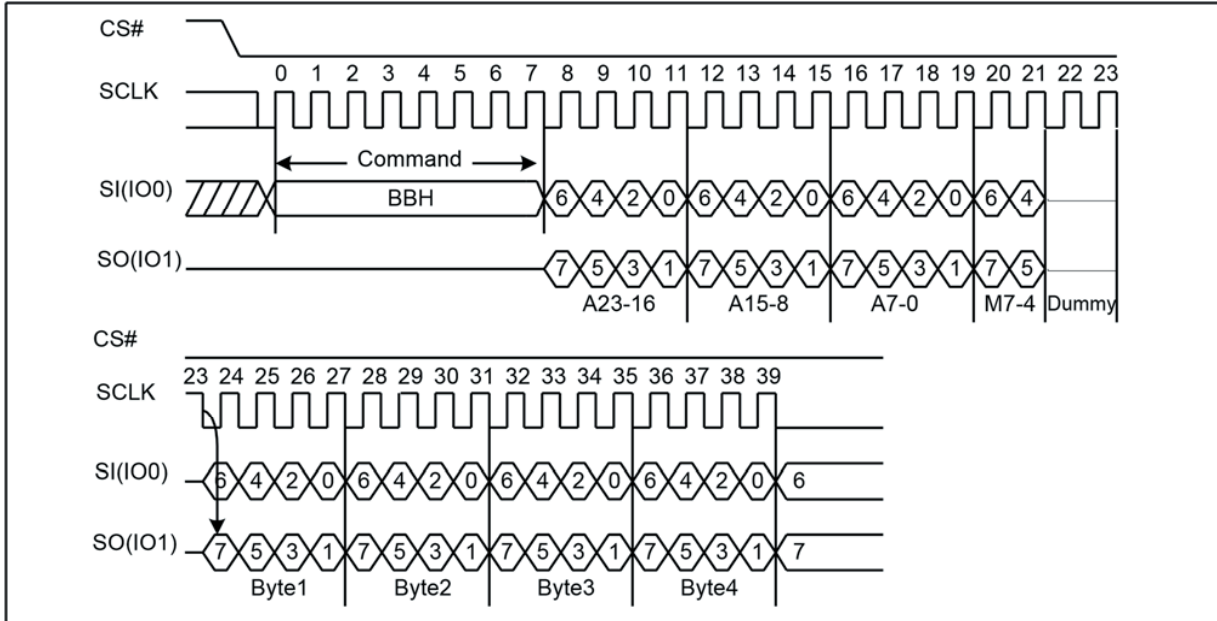
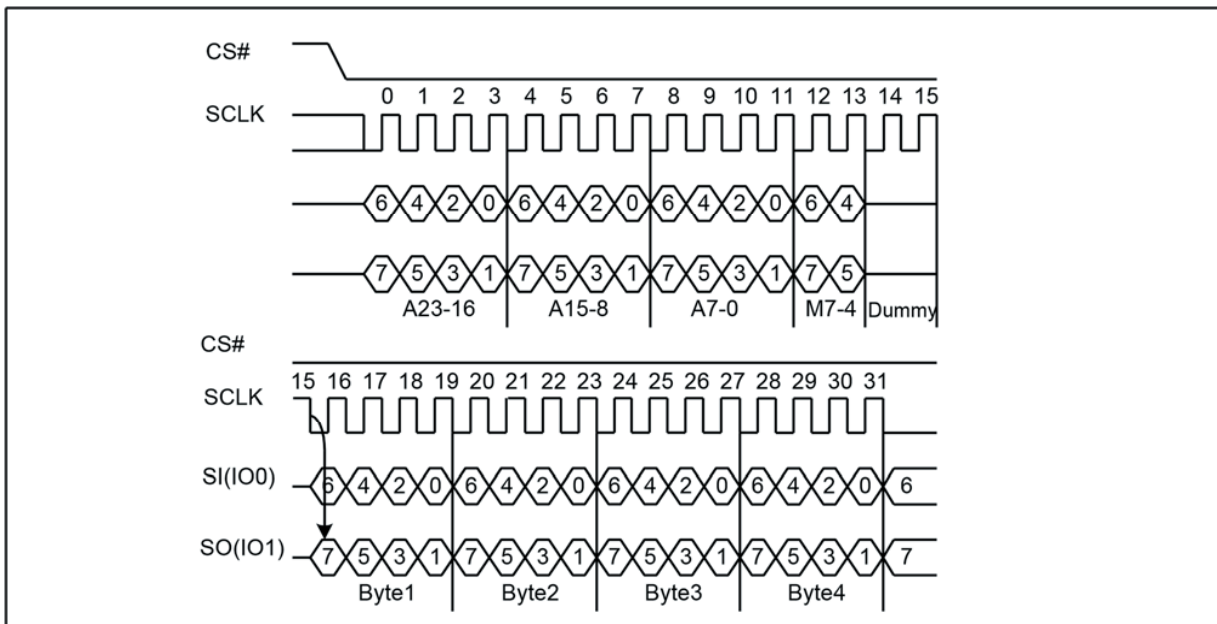

Figure 12. Dual I/O Fast Read Sequence Diagram (M7-0 = AXH)



GD25Q16CxIGx 3.3V Uniform Sector Dual and Quad Serial Flash

7.11. Quad I/O Fast Read (EBH)

The Quad I/O Fast Read command is similar to the Dual I/O Fast Read command but with the capability to input the 3-byte address (A23-0) and a “Continuous Read Mode” byte and 4-dummy clock 4-bit per clock by IO0, IO1, IO2, IO3, each bit being latched in during the rising edge of SCLK, then the memory contents are shifted out 4-bit per clock cycle from IO0, IO1, IO2, IO3. The command sequence is shown in followed Figure13. The first byte addressed can be at any location. The address is automatically incremented to the next higher address after each byte of data is shifted out. The Quad Enable bit (QE) of Status Register (S9) must be set to enable for the Quad I/O Fast read command.

Quad I/O Fast Read with “Continuous Read Mode”

The Quad I/O Fast Read command can further reduce command overhead through setting the “Continuous Read Mode” bits (M7-0) after the input 3-byte address (A23-A0). If the “Continuous Read Mode” bits (M7-0) = AXH, then the next Quad I/O Fast Read command (after CS# is raised and then lowered) does not require the EBH command code. The command sequence is shown in followed Figure14. If the “Continuous Read Mode” bits (M7-0) are any value other than AXH, the next command requires the first EBH command code, thus returning to normal operation. A “Continuous Read Mode” Reset command can be used to reset (M7-0) before issuing normal command.

Figure 13. Quad I/O Fast Read Sequence Diagram (M7-0 = 0XH or not AXH)

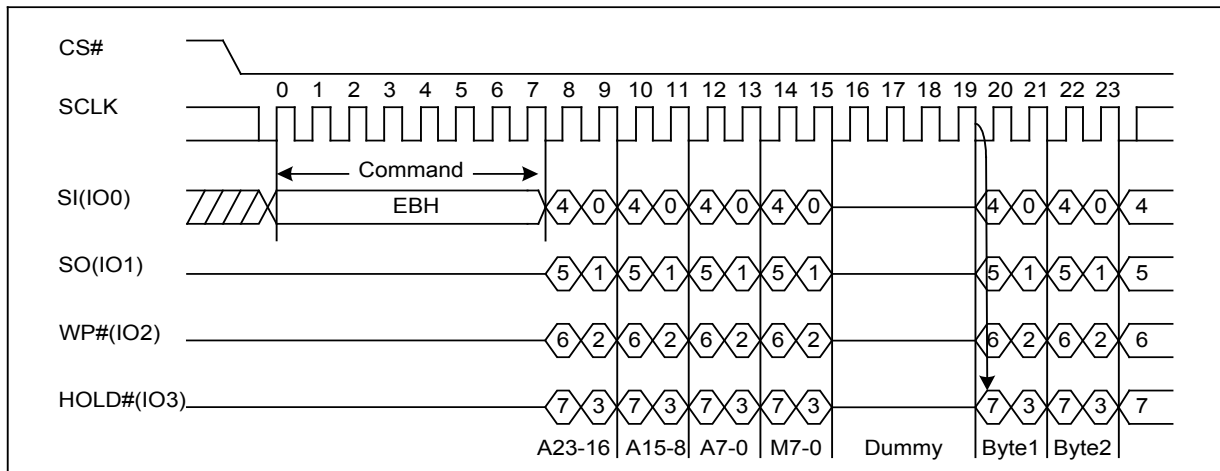
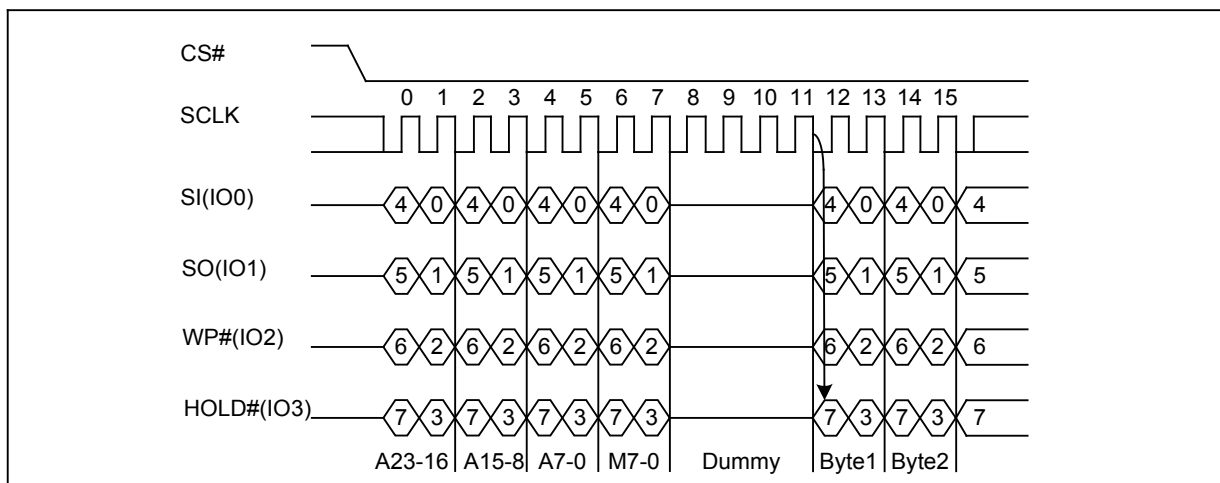

Figure 14. Quad I/O Fast Read Sequence Diagram (M7-0 = AXH)



GD25Q16CxIGx 3.3V Uniform Sector Dual and Quad Serial Flash

7.12. Quad I/O Word Fast Read (E7H)

The Quad I/O Word Fast Read command is similar to the Quad I/O Fast Read command except that the lowest address bit (A0) must equal 0 and only 2-dummy clock. The command sequence is shown in followed Figure15. The first byte addressed can be at any location. The address is automatically incremented to the next higher address after each byte of data is shifted out. The Quad Enable bit (QE) of Status Register (S9) must be set to enable for the Quad I/O Word Fast read command.

Quad I/O Word Fast Read with “Continuous Read Mode”

The Quad I/O Word Fast Read command can further reduce command overhead through setting the “Continuous Read Mode” bits (M7-0) after the input 3-byte address (A23-A0). If the “Continuous Read Mode” bits (M7-0) =AXH, then the next Quad I/O Word Fast Read command (after CS# is raised and then lowered) does not require the E7H command code. The command sequence is shown in followed Figure16. If the “Continuous Read Mode” bits (M7-0) are any value other than AXH, the next command requires the first E7H command code, thus returning to normal operation. A “Continuous Read Mode” Reset command can be used to reset (M7-0) before issuing normal command.

Figure 15. Quad I/O Word Fast Read Sequence Diagram (M7-0 = 0XH or not AXH)

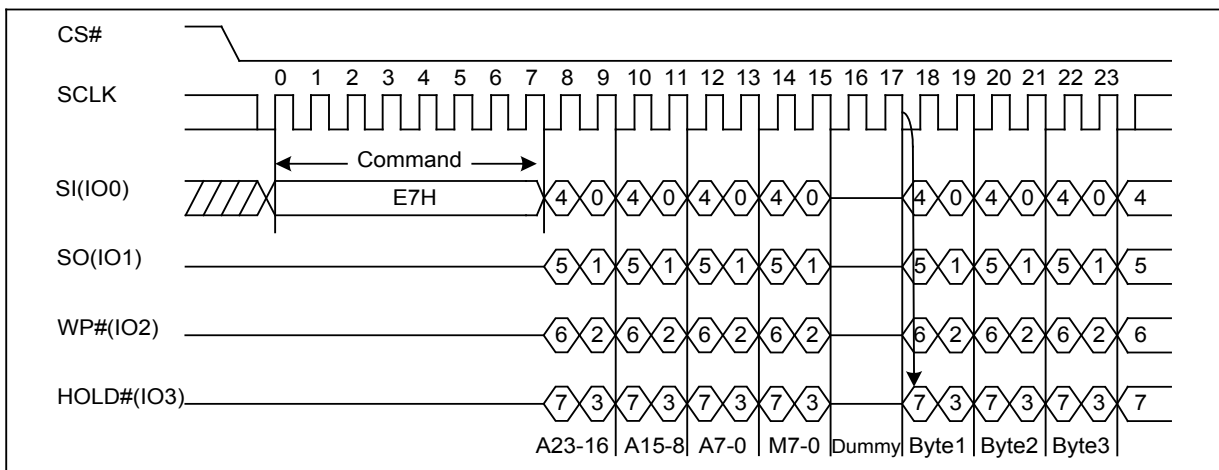
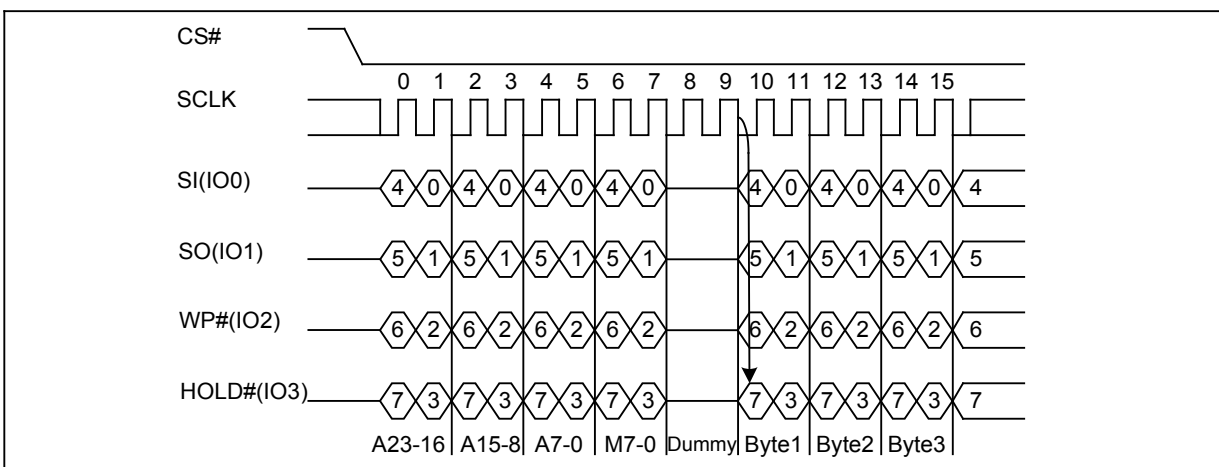

Figure 16. Quad I/O Word Fast Read Sequence Diagram (M7-0 = AXH)



GD25Q16CxIGx 3.3V Uniform Sector Dual and Quad Serial Flash

7.13. Page Program (PP) (02H)

The Page Program (PP) command is for programming the memory. A Write Enable (WREN) command must previously have been executed to set the Write Enable Latch (WEL) bit before sending the Page Program command.

The Page Program (PP) command is entered by driving CS# Low, followed by the command code, three address bytes and at least one data byte on SI. If the 8 least significant address bits (A7-A0) are not all zero, all transmitted data that goes beyond the end of the current page are programmed from the start address of the same page (from the address whose 8 least significant bits (A7-A0) are all zero). CS# must be driven low for the entire duration of the sequence.

The Page Program command sequence: CS# goes low → sending Page Program command → 3-byte address on SI → at least 1 byte data on SI → CS# goes high. The command sequence is shown in Figure 17. If more than 256 bytes are sent to the device, previously latched data are discarded and the last 256 data bytes are guaranteed to be programmed correctly within the same page. If less than 256 data bytes are sent to device, they are correctly programmed at the requested addresses without having any effects on the other bytes of the same page. CS# must be driven high after the eighth bit of the last data byte has been latched in; otherwise the Page Program (PP) command is not executed.

As soon as CS# is driven high, the self-timed Page Program cycle (whose duration is t_{pp}) is initiated. While the Page Program cycle is in progress, the Status Register may be read to check the value of the Write In Progress (WIP) bit. The Write In Progress (WIP) bit is 1 during the self-timed Page Program cycle, and is 0 when it is completed. At some unspecified time before the cycle is completed, the Write Enable Latch (WEL) bit is reset.

A Page Program (PP) command applied to a page which is protected by the Block Protect (BP4, BP3, BP2, BP1 and BP0) is not executed.

Figure 17. Page Program Sequence Diagram

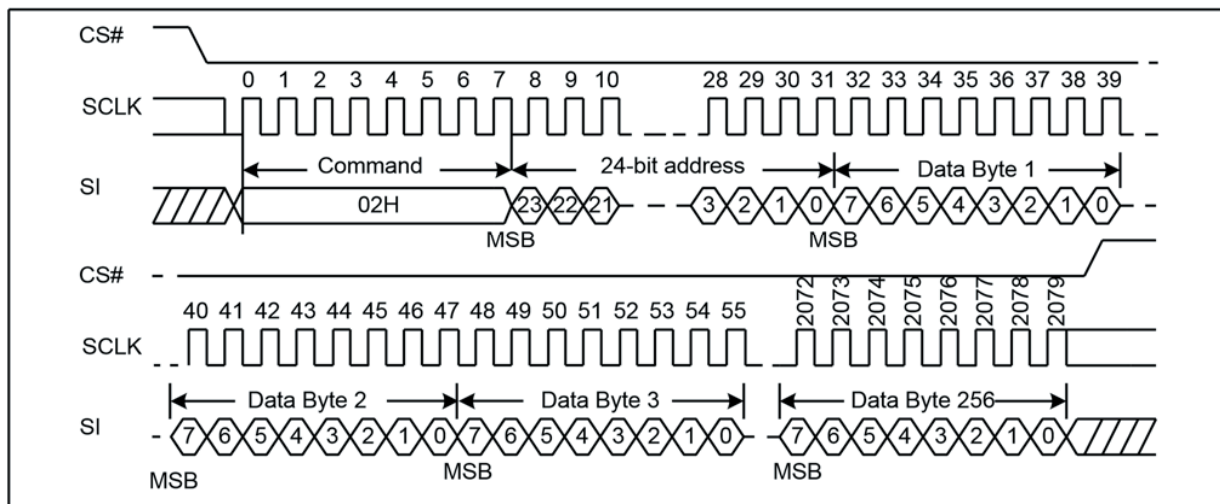

GD25Q16CxIGx 3.3V Uniform Sector Dual and Quad Serial Flash

7.14. Quad Page Program (32H)

The Quad Page Program command is for programming the memory using four pins: IO0, IO1, IO2 and IO3. To use Quad Page Program the Quad enable in status register Bit9 must be set (QE=1). A Write Enable (WREN) command must previously have been executed to set the Write Enable Latch (WEL) bit before sending the Page Program command. The quad Page Program command is entered by driving CS# Low, followed by the command code (32H), three address bytes and at least one data byte on IO pins.

The command sequence is shown in Figure18. If more than 256 bytes are sent to the device, previously latched data are discarded and the last 256 data bytes are guaranteed to be programmed correctly within the same page. If less than 256 data bytes are sent to device, they are correctly programmed at the requested addresses without having any effects on the other bytes of the same page. CS# must be driven high after the eighth bit of the last data byte has been latched in; otherwise the Quad Page Program (PP) command is not executed.

As soon as CS# is driven high, the self-timed Quad Page Program cycle (whose duration is t_{pp}) is initiated. While the Quad Page Program cycle is in progress, the Status Register may be read to check the value of the Write In Progress (WIP) bit. The Write in Progress (WIP) bit is 1 during the self-timed Quad Page Program cycle, and is 0 when it is completed. At some unspecified time before the cycle is completed, the Write Enable Latch (WEL) bit is reset.

A Quad Page Program command applied to a page which is protected by the Block Protect (BP4, BP3, BP2, BP1 and BP0) is not executed.

Figure 18. Quad Page Program Sequence Diagram

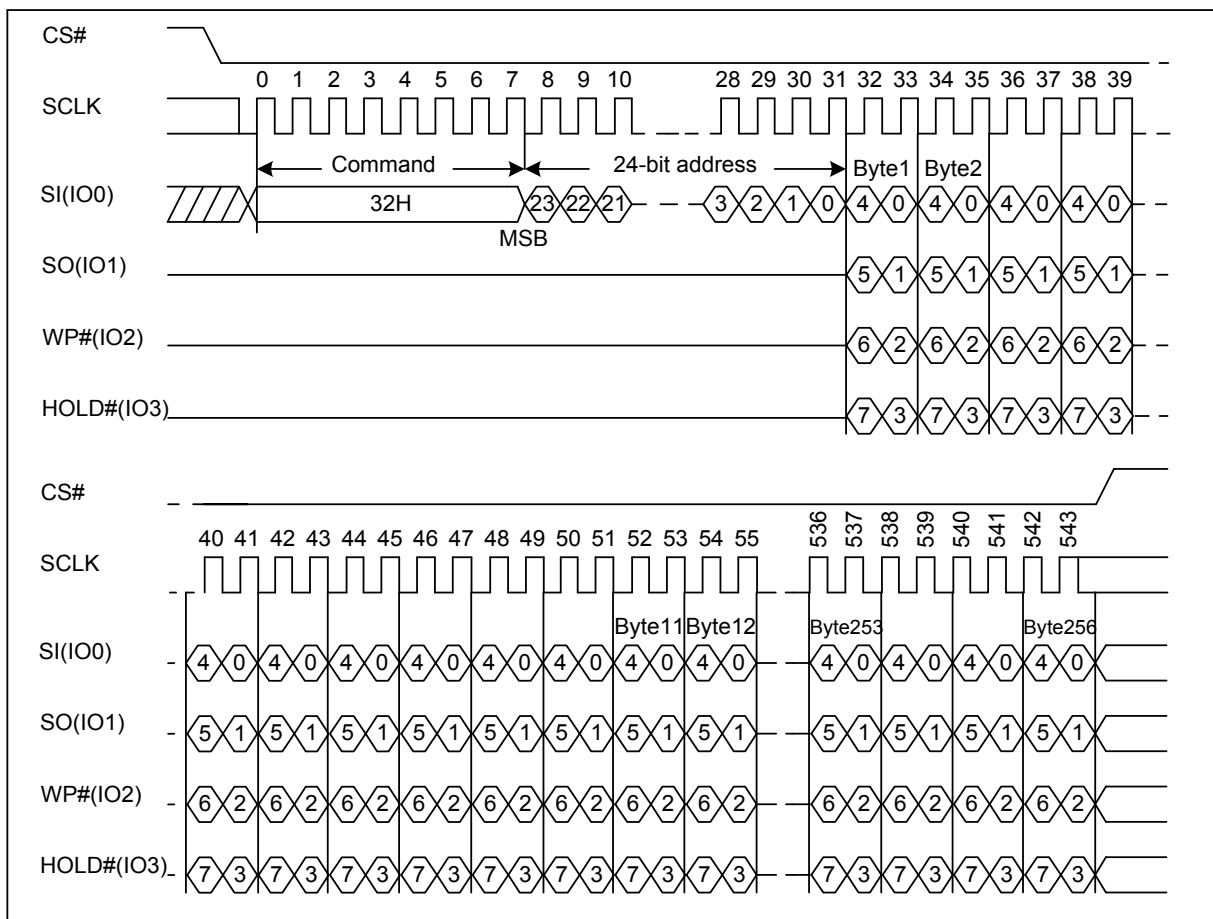

GD25Q16CxIGx 3.3V Uniform Sector Dual and Quad Serial Flash

7.15. Sector Erase (SE) (20H)

The Sector Erase (SE) command is used to erase all the data of the chosen sector. A Write Enable (WREN) command must previously have been executed to set the Write Enable Latch (WEL) bit. The Sector Erase (SE) command is entered by driving CS# low, followed by the command code, and 3-address byte on SI. Any address inside the sector is a valid address for the Sector Erase (SE) command. CS# must be driven low for the entire duration of the sequence.

The Sector Erase command sequence: CS# goes low → sending Sector Erase command → 3-byte address on SI → CS# goes high. The command sequence is shown in Figure 19. CS# must be driven high after the eighth bit of the last address byte has been latched in; otherwise the Sector Erase (SE) command is not executed. As soon as CS# is driven high, the self-timed Sector Erase cycle (whose duration is t_{SE}) is initiated. While the Sector Erase cycle is in progress, the Status Register may be read to check the value of the Write In Progress (WIP) bit. The Write In Progress (WIP) bit is 1 during the self-timed Sector Erase cycle, and is 0 when it is completed. At some unspecified time before the cycle is completed, the Write Enable Latch (WEL) bit is reset. A Sector Erase (SE) command applied to a sector which is protected by the Block Protect (BP4, BP3, BP2, BP1 and BP0) bit (see Table 1 & Table 1.1.) is not executed.

Figure 19. Sector Erase Sequence Diagram

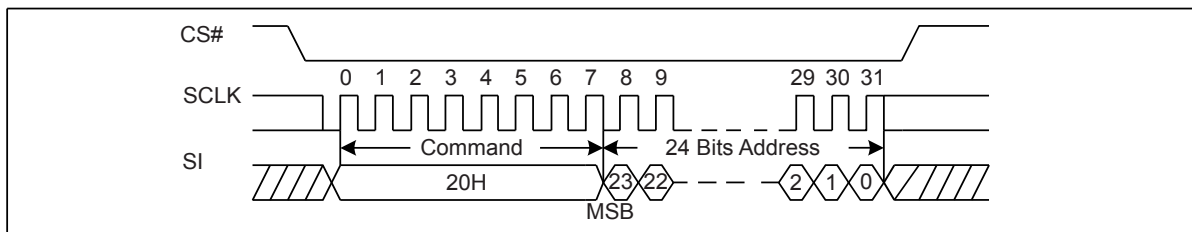

7.16. 32KB Block Erase (BE) (52H)

The 32KB Block Erase (BE) command is used to erase all the data of the chosen block. A Write Enable (WREN) command must previously have been executed to set the Write Enable Latch (WEL) bit. The 32KB Block Erase (BE) command is entered by driving CS# low, followed by the command code, and three address bytes on SI. Any address inside the block is a valid address for the 32KB Block Erase (BE) command. CS# must be driven low for the entire duration of the sequence.

The 32KB Block Erase command sequence: CS# goes low → sending 32KB Block Erase command → 3-byte address on SI → CS# goes high. The command sequence is shown in Figure 20. CS# must be driven high after the eighth bit of the last address byte has been latched in; otherwise the 32KB Block Erase (BE) command is not executed. As soon as CS# is driven high, the self-timed Block Erase cycle (whose duration is t_{BE}) is initiated. While the Block Erase cycle is in progress, the Status Register may be read to check the value of the Write In Progress (WIP) bit. The Write In Progress (WIP) bit is 1 during the self-timed Block Erase cycle, and is 0 when it is completed. At some unspecified time before the cycle is completed, the Write Enable Latch (WEL) bit is reset. A 32KB Block Erase (BE) command applied to a block which is protected by the Block Protect (BP4, BP3, BP2, BP1 and BP0) bits (see Table 1. & Table 1.1.) is not executed.

GD25Q16CxIGx 3.3V Uniform Sector Dual and Quad Serial Flash

Figure 20. 32KB Block Erase Sequence Diagram

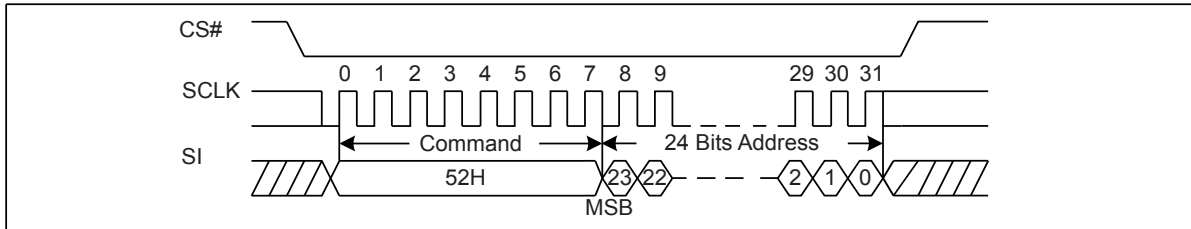

7.17. 64KB Block Erase (BE) (D8H)

The 64KB Block Erase (BE) command is used to erase all the data of the chosen block. A Write Enable (WREN) command must previously have been executed to set the Write Enable Latch (WEL) bit. The 64KB Block Erase (BE) command is entered by driving CS# low, followed by the command code, and three address bytes on SI. Any address inside the block is a valid address for the 64KB Block Erase (BE) command. CS# must be driven low for the entire duration of the sequence.

The 64KB Block Erase command sequence: CS# goes low → sending 64KB Block Erase command → 3-byte address on SI → CS# goes high. The command sequence is shown in Figure 21. CS# must be driven high after the eighth bit of the last address byte has been latched in; otherwise the 64KB Block Erase (BE) command is not executed. As soon as CS# is driven high, the self-timed Block Erase cycle (whose duration is t_{BE}) is initiated. While the Block Erase cycle is in progress, the Status Register may be read to check the value of the Write In Progress (WIP) bit. The Write In Progress (WIP) bit is 1 during the self-timed Block Erase cycle, and is 0 when it is completed. At some unspecified time before the cycle is completed, the Write Enable Latch (WEL) bit is reset. A 64KB Block Erase (BE) command applied to a block which is protected by the Block Protect (BP4, BP3, BP2, BP1 and BP0) bits (see Table 1. & Table 1.1.) is not executed.

Figure 21. 64KB Block Erase Sequence Diagram

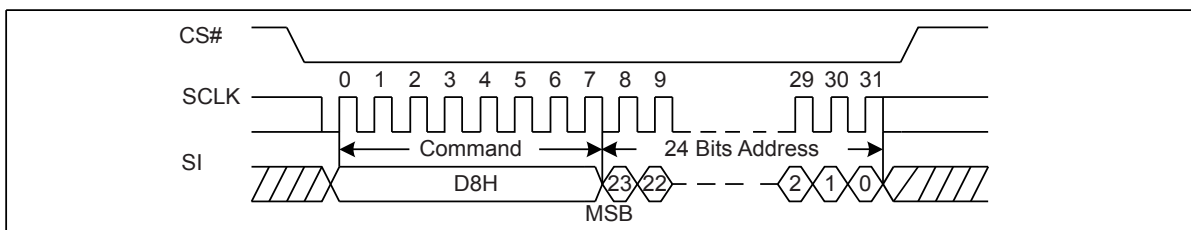

7.18. Chip Erase (CE) (60/C7H)

The Chip Erase (CE) command is used to erase all the data of the chip. A Write Enable (WREN) command must previously have been executed to set the Write Enable Latch (WEL) bit. The Chip Erase (CE) command is entered by driving CS# Low, followed by the command code on Serial Data Input (SI). CS# must be driven Low for the entire duration of the sequence.

The Chip Erase command sequence: CS# goes low → sending Chip Erase command → CS# goes high. The command sequence is shown in Figure 22. CS# must be driven high after the eighth bit of the command code has been latched in; otherwise the Chip Erase command is not executed. As soon as CS# is driven high, the self-timed Chip Erase cycle (whose duration is t_{CE}) is initiated. While the Chip Erase cycle is in progress, the Status Register may be read to check the value of the Write In Progress (WIP) bit. The Write In Progress (WIP) bit is 1 during the self-timed Chip Erase cycle, and is 0 when it is completed. At some unspecified time before the cycle

GD25Q16CxIGx 3.3V Uniform Sector Dual and Quad Serial Flash

<http://www.elm-tech.com>

is completed, the Write Enable Latch (WEL) bit is reset. The Chip Erase (CE) command is executed only if all Block Protect (BP2, BP1 and BP0) bits are 0. The Chip Erase (CE) command is ignored if one or more sectors are protected.

Figure 22. Chip Erase Sequence Diagram

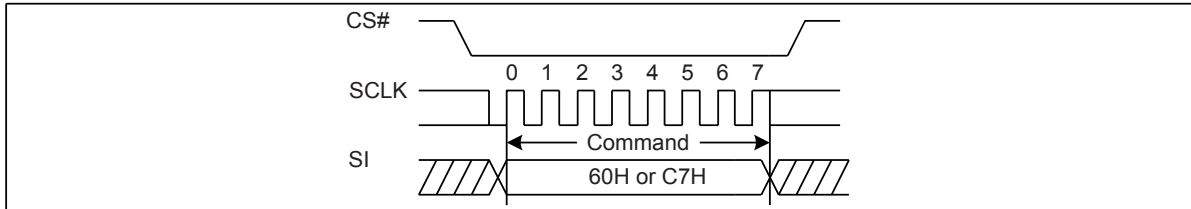

7.19. Deep Power-Down (DP) (B9H)

Executing the Deep Power-Down (DP) command is the only way to put the device in the lowest consumption mode (the Deep Power-Down Mode). It can also be used as an extra software protection mechanism, while the device is not in active use, since in this mode, the device ignores all Write, Program and Erase commands. Driving CS# high deselects the device, and puts the device in the Standby Mode (if there is no internal cycle currently in progress). But this mode is not the Deep Power-Down Mode. The Deep Power-Down Mode can only be entered by executing the Deep Power-Down (DP) command. Once the device has entered the Deep Power-Down Mode, all commands are ignored except the Release from Deep Power-Down and Read Device ID (RDI) command. This releases the device from this mode. The Release from Deep Power-Down and Read Device ID (RDI) command also allows the Device ID of the device to be output on SO.

The Deep Power-Down Mode automatically stops at Power-Down, and the device always Power-Up in the Standby Mode. The Deep Power-Down (DP) command is entered by driving CS# low, followed by the command code on SI. CS# must be driven low for the entire duration of the sequence.

The Deep Power-Down command sequence: CS# goes low → sending Deep Power-Down command → CS# goes high. The command sequence is shown in Figure 23. CS# must be driven high after the eighth bit of the command code has been latched in; otherwise the Deep Power-Down (DP) command is not executed. As soon as CS# is driven high, it requires a delay of t_{DP} before the supply current is reduced to I_{CC2} and the Deep Power-Down Mode is entered. Any Deep Power-Down (DP) command, while an Erase, Program or Write cycle is in progress, is rejected without having any effects on the cycle that is in progress.

Figure 23. Deep Power-Down Sequence Diagram

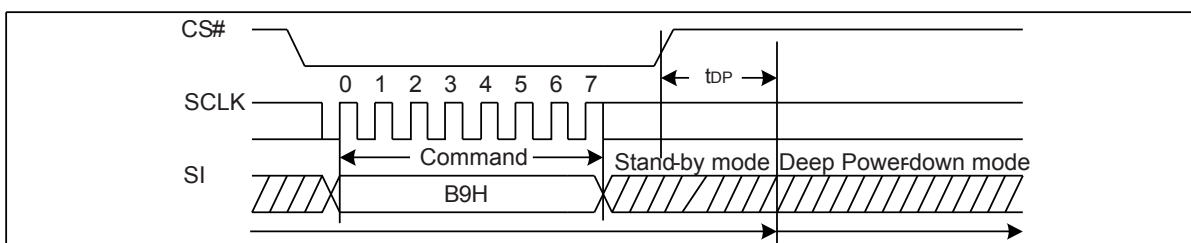

GD25Q16CxIGx 3.3V Uniform Sector Dual and Quad Serial Flash

<http://www.elm-tech.com>

7.20. Release from Deep Power-Down or High Performance Mode and Read Device ID (RDI) (ABH)

The Release from Power-Down or High Performance Mode/Device ID command is a multi-purpose command. It can be used to release the device from the Power-Down state or High Performance Mode or obtain the devices electronic identification (ID) number.

To release the device from the Power-Down state or High Performance Mode, the command is issued by driving the CS# pin low, shifting the instruction code “ABH” and driving CS# high as shown in Figure24. Release from Power-Down will take the time duration of t_{RES1} (See AC Characteristics) before the device will resume normal operation and other command are accepted. The CS# pin must remain high during the t_{RES1} time duration.

When used only to obtain the Device ID while not in the Power-Down state, the command is initiated by driving the CS# pin low and shifting the instruction code “ABH” followed by 3-dummy byte. The Device ID bits are then shifted out on the falling edge of SCLK with most significant bit (MSB) first as shown in Figure25. The Device ID value is listed in Manufacturer and Device Identification table. The Device ID can be read continuously. The command is completed by driving CS# high.

When used to release the device from the Power-Down state and obtain the Device ID, the command is the same as previously described, and shown in Figure25, except that after CS# is driven high it must remain high for a time duration of t_{RES2} (See AC Characteristics). After this time duration the device will resume normal operation and other command will be accepted. If the Release from Power-Down/Device ID command is issued while an Erase, Program or Write cycle is in process (when WIP equal 1) the command is ignored and will not have any effects on the current cycle.

Figure 24. Release Power-Down Sequence or High Performance Mode Sequence Diagram

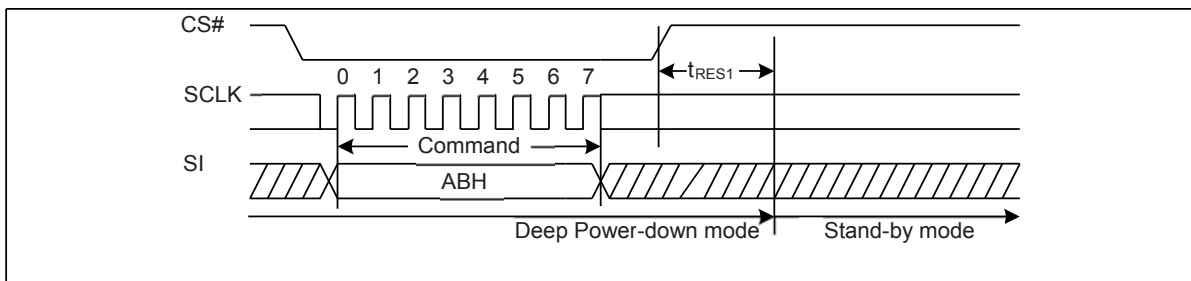
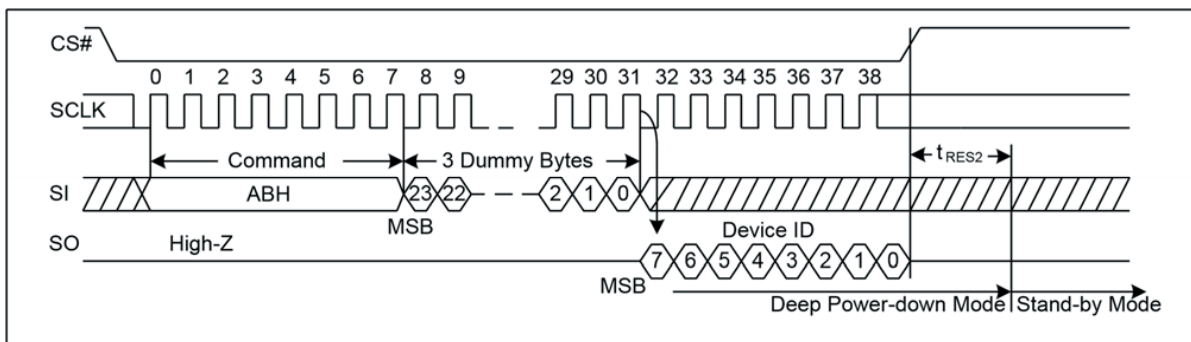

Figure 25. Release Power-Down and Read Device ID Sequence Diagram



GD25Q16CxIGx 3.3V Uniform Sector Dual and Quad Serial Flash

7.21. Read Manufacture ID/Device ID (REMS) (90H)

The Read Manufacturer/Device ID command is an alternative to the Release from Power-Down/Device ID command that provides both the JEDEC assigned Manufacturer ID and the specific Device ID.

The command is initiated by driving the CS# pin low and shifting the command code “90H” followed by a 24-bit address (A23-A0) of 000000H. After which, the Manufacturer ID and the Device ID are shifted out on the falling edge of SCLK with most significant bit (MSB) first as shown in Figure26. If the 24-bit address is initially set to 000001H, the Device ID will be read first.

Figure 26. Read Manufacture ID/Device ID Sequence Diagram

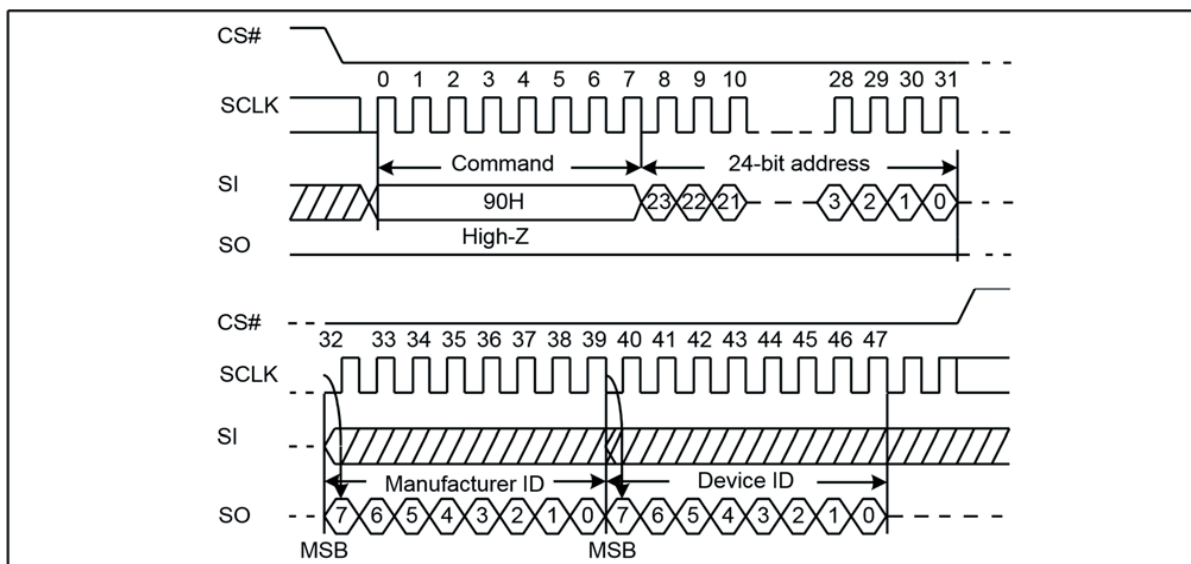

7.22. Read Identification (RDID) (9FH)

The Read Identification (RDID) command allows the 8-bit manufacturer identification to be read, followed by two bytes of device identification. The device identification indicates the memory type in the first byte, and the memory capacity of the device in the second byte. The Read Identification (RDID) command while an Erase or Program cycle is in progress is not decoded, and has no effect on the cycle that is in progress. The Read Identification (RDID) command should not be issued while the device is in Deep Power-Down Mode.

The device is first selected by driving CS# to low. Then, the 8-bit command code for the command is shifted in. This is followed by the 24-bit device identification, stored in the memory, being shifted out on Serial Data Output, each bit being shifted out during the falling edge of Serial Clock. The command sequence is shown in Figure27. The Read Identification (RDID) command is terminated by driving CS# to high at any time during data output. When CS# is driven high, the device is put in the Standby Mode. Once in the Standby Mode, the device waits to be selected, so that it can receive, decode and execute commands.

GD25Q16CxIGx 3.3V Uniform Sector Dual and Quad Serial Flash

Figure 27. Read Identification ID Sequence Diagram

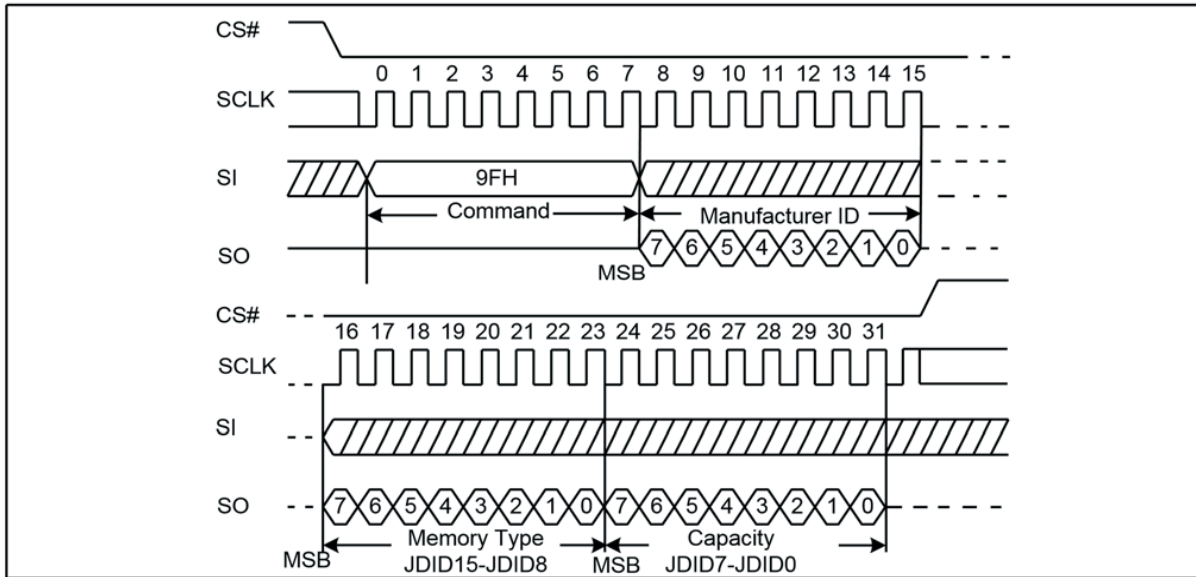

7.23. High Performance Mode (HPM) (A3H)

The High Performance Mode (HPM) command must be executed prior to Dual or Quad I/O commands when operating at high frequencies (see f_R and f_{C1} in AC Electrical Characteristics). This command allows pre-charging of internal charge pumps so the voltages required for accessing the flash memory array are readily available. The command sequence: CS# goes low → Sending A3H command → Sending 3-dummy byte → CS# goes high. See Figure28. After the HPM command is executed, the device will maintain a slightly higher standby current (I_{cc8}) than standard SPI operation. The Release from Power-Down or HPM command (ABH) can be used to return to standard SPI standby current (I_{cc1}). In addition, Power-Down command (B9H) will also release the device from HPM mode back to standard SPI standby state.

Figure 28. High Performance Mode Sequence Diagram

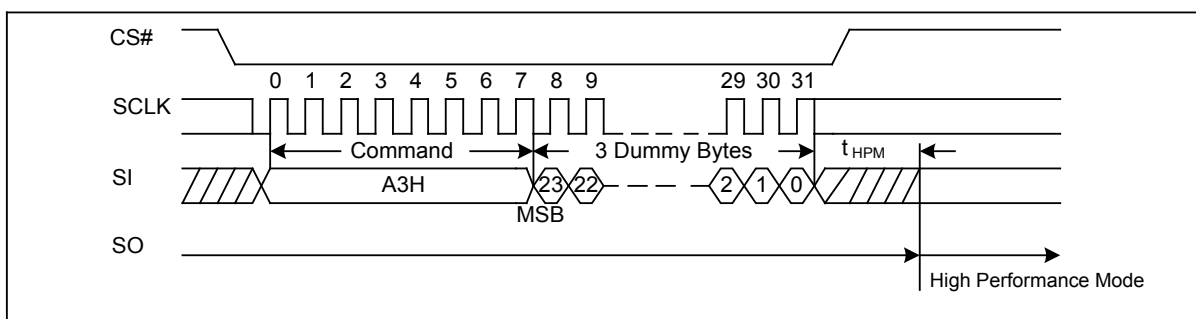

GD25Q16CxIGx 3.3V Uniform Sector Dual and Quad Serial Flash

7.24. Continuous Read Mode Reset (CRMR) (FFH)

The Dual/Quad I/O Fast Read operations, “Continuous Read Mode” bits (M7-0) are implemented to further reduce command overhead. By setting the (M7-0) to AXH, the next Dual/Quad I/O Fast Read operations do not require the BBH/EBH/E7H command code.

Because the GD25Q16C has no hardware reset pin, so if Continuous Read Mode bits are set to “AXH”, the GD25Q16C will not recognize any standard SPI commands. So Continuous Read Mode Reset command will release the Continuous Read Mode from the “AXH” state and allow standard SPI command to be recognized. The command sequence is show in Figure29.

Figure 29. Continuous Read Mode Reset Sequence Diagram

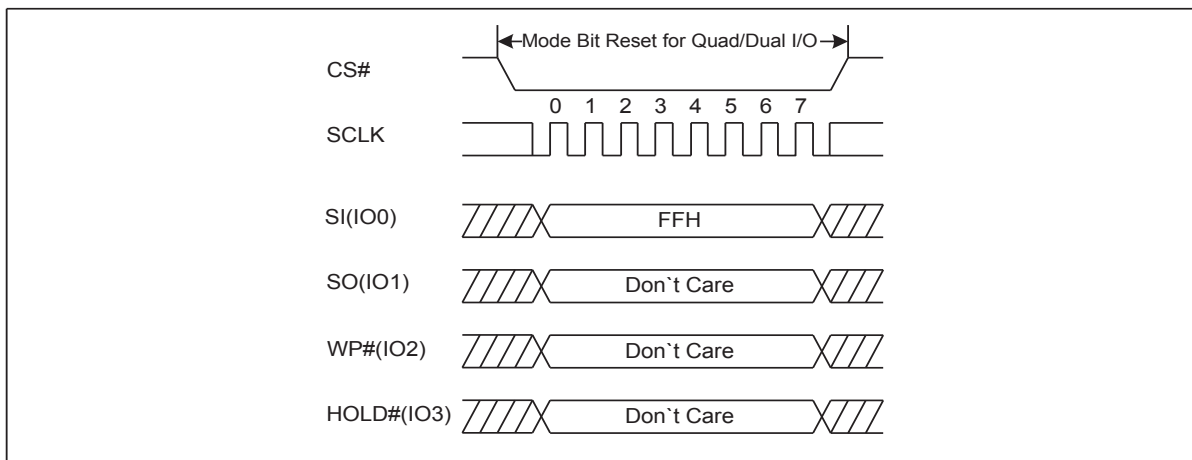

7.25. Read Unique ID (4BH)

The Read Unique ID command accesses a factory-set read-only. 128bit number that is unique to each GD25Q16C device. The Unique ID can be used in conjunction with user software methods to help prevent copying or cloning of a system. The Read Unique ID command sequence: CS# goes low → sending Read Unique ID command → Dummy Byte1 → Dummy Byte2 → Dummy Byte3 → Dummy Byte4 → 128bit Unique ID Out → CS# goes high. The command sequence is show below.

Figure 30. Read Unique ID Sequence Diagram

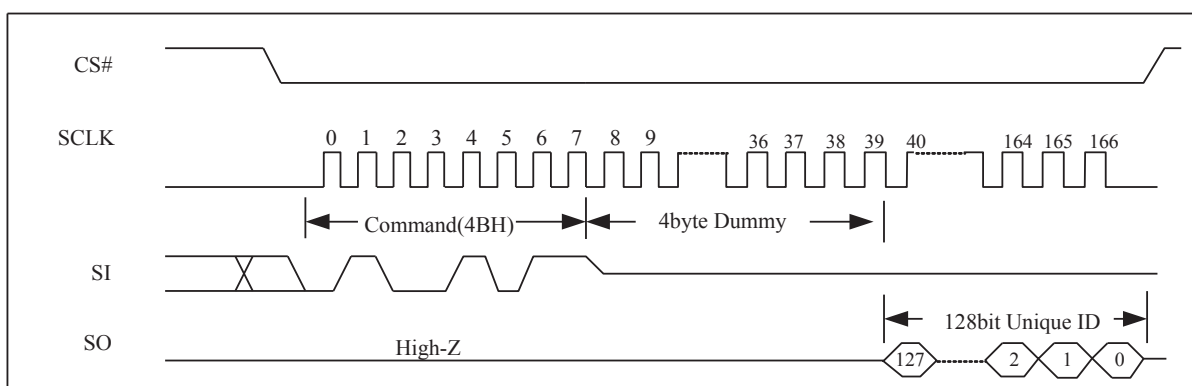

GD25Q16CxIGx 3.3V Uniform Sector Dual and Quad Serial Flash

7.26. Program/Erase Suspend (PES) (75H)

The Program/Erase Suspend command “75H”, allows the system to interrupt a page program or sector/block erase operation and then read data from any other sector or block. The Write Status Register command (01H) and Erase/Program Security Registers command (44H, 42H) and Erase commands (20H, 52H, D8H, C7H, 60H) and Page Program command (02H/32H) are not allowed during Program/Erase suspend. Program/Erase Suspend is valid only during the page program or sector/block erase operation. A maximum of time of “tsus” (See AC Characteristics) is required to suspend the program/erase operation.

The Program/Erase Suspend command will be accepted by the device only if the SUS bit in the Status Register equal to 0 and WIP bit equal to 1 while a Page Program or a Sector or Block Erase operation is on-going. If the SUS bit equal to 1 or WIP bit equal to 0, the Suspend command will be ignored by the device. The WIP bit will be cleared from 1 to 0 within “tsus” and the SUS bit will be set from 0 to 1 immediately after Program/Erase Suspend. A power-off during the suspend period will reset the device and release the suspend state. The command sequence is show in Figure31.

Figure 31. Program/Erase Suspend Sequence Diagram

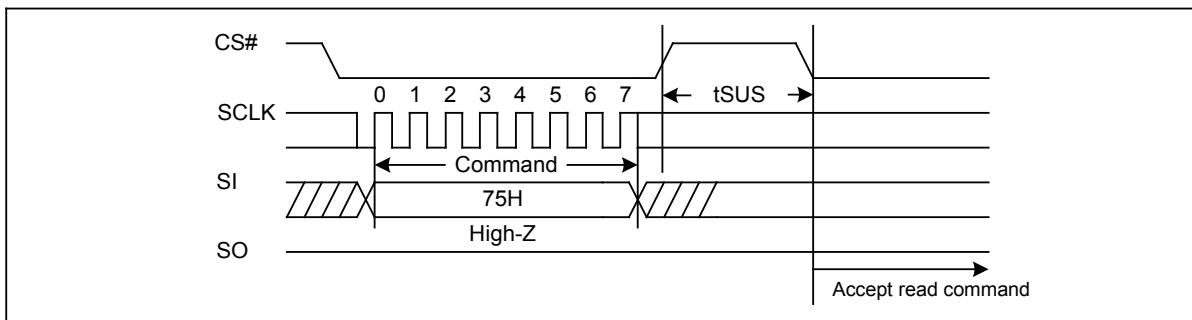

7.27. Program/Erase Resume (PER) (7AH)

The Program/Erase Resume command must be written to resume the program or sector/block erase operation after a Program/Erase Suspend command. The Program/Erase command will be accepted by the device only if the SUS bit equal to 1 and the WIP bit equal to 0. After issued the SUS bit in the status register will be cleared from 1 to 0 immediately, the WIP bit will be set from 0 to 1 within 200ns and the Sector or Block will complete the erase operation or the page will complete the program operation. The Program/Erase Resume command will be ignored unless a Program/Erase Suspend is active. The command sequence is show in Figure32.

Figure 32. Program/Erase Resume Sequence Diagram

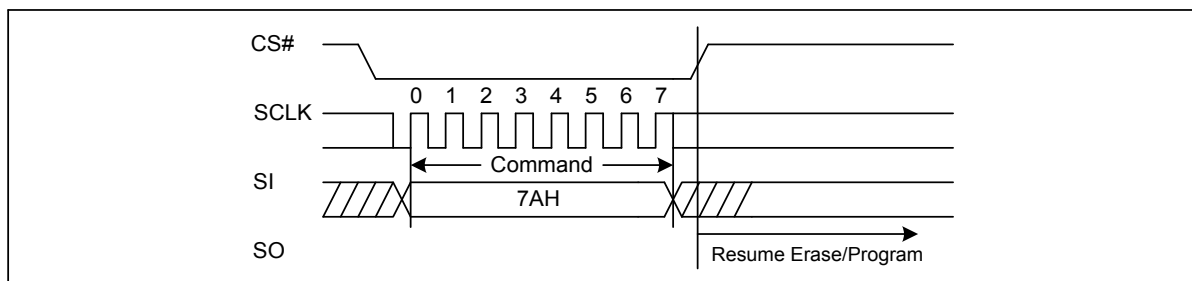

GD25Q16CxIGx 3.3V Uniform Sector Dual and Quad Serial Flash

7.28. Erase Security Registers (44H)

The GD25Q16C provides four 256-byte Security Registers which can be erased and programmed individually. These registers may be used by the system manufacturers to store security and other important information separately from the main memory array.

The Erase Security Registers command is similar to Sector/Block Erase command. A Write Enable (WREN) command must previously have been executed to set the Write Enable Latch (WEL) bit.

The Erase Security Registers command sequence: CS# goes low → sending Erase Security Registers command → CS# goes high. The command sequence is shown in Figure33. CS# must be driven high after the eighth bit of the command code has been latched in; otherwise the Erase Security Registers command is not executed. As soon as CS# is driven high, the self-timed Erase Security Registers cycle (whose duration is t_{SE}) is initiated. While the Erase Security Registers cycle is in progress, the Status Register may be read to check the value of the Write in Progress (WIP) bit. The Write in Progress (WIP) bit is 1 during the self-timed Erase Security Registers cycle, and is 0 when it is completed. At some unspecified time before the cycle is completed, the Write Enable Latch (WEL) bit is reset. The Security Registers Lock Bit (LB) in the Status Register can be used to OTP protect the security registers. Once the LB bit is set to 1, the Security Registers will be permanently locked; the Erase Security Registers command will be ignored.

Address	A23-A16	A15-A10	A9-A0
Security Register	00000000	000000	Don't Care

Figure 33. Erase Security Registers command Sequence Diagram

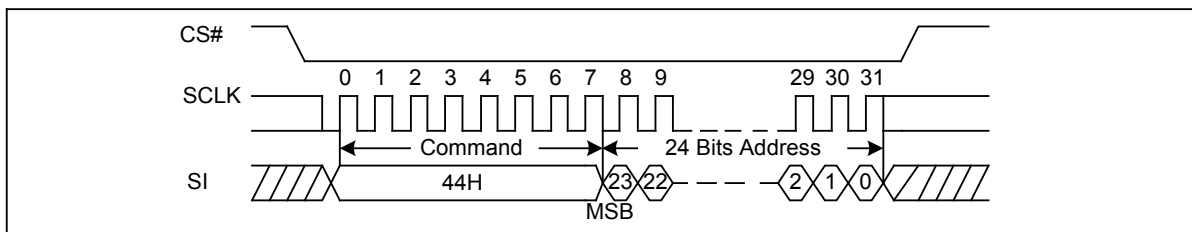

7.29. Program Security Registers (42H)

The Program Security Registers command is similar to the Page Program command. It allows from 1 to 256 bytes Security Registers data to be programmed. A Write Enable (WREN) command must previously have been executed to set the Write Enable Latch (WEL) bit before sending the Program Security Registers command. The Program Security Registers command is entered by driving CS# Low, followed by the command code (42H), three address bytes and at least one data byte on SI. As soon as CS# is driven high, the self-timed Program Security Registers cycle (whose duration is t_{PP}) is initiated. While the Program Security Registers cycle is in progress, the Status Register may be read to check the value of the Write in Progress (WIP) bit. The Write in Progress (WIP) bit is 1 during the self-timed Program Security Registers cycle, and is 0 when it is completed. At some unspecified time before the cycle is completed, the Write Enable Latch (WEL) bit is reset.

If the Security Registers Lock Bit (LB) is set to 1, the Security Registers will be permanently locked. Program Security Registers command will be ignored.

GD25Q16CxIGx 3.3V Uniform Sector Dual and Quad Serial Flash

<http://www.elm-tech.com>

Address	A23-A16	A15-A8	A7-A0
Security Register #0	00H	00H	Byte Address
Security Register #1	00H	01H	Byte Address
Security Register #2	00H	02H	Byte Address
Security Register #3	00H	03H	Byte Address

Figure 34. Program Security Registers command Sequence Diagram

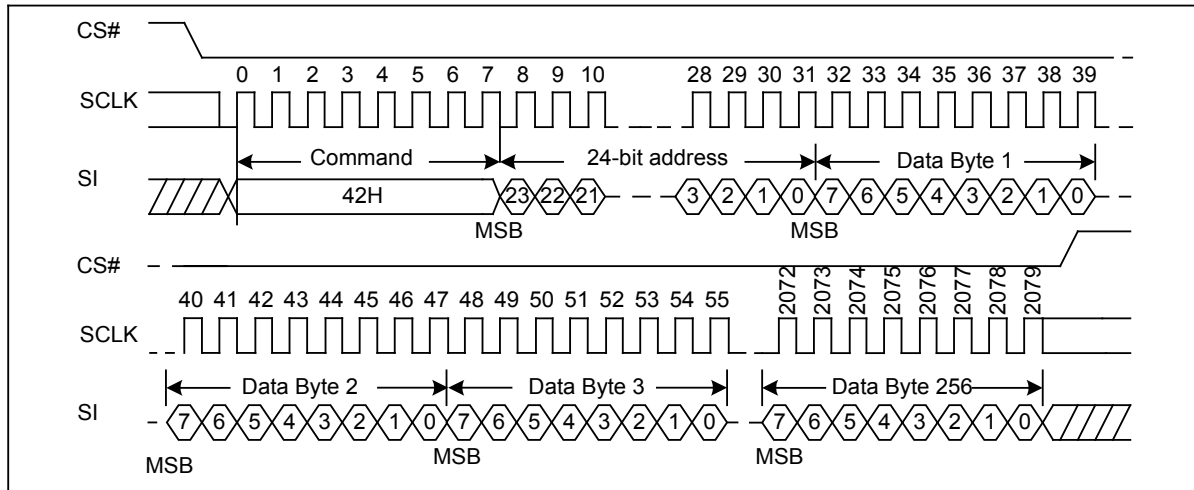

7.30. Read Security Registers (48H)

The Read Security Registers command is similar to Fast Read command. The command is followed by a 3-byte address (A23-A0) and a dummy byte, each bit being latched-in during the rising edge of SCLK. Then the memory content, at that address, is shifted out on SO, each bit being shifted out, at a Max frequency f_c , during the falling edge of SCLK. The first byte addressed can be at any location. The address is automatically incremented to the next higher address after each byte of data is shifted out. Once the A9-A0 address reaches the last byte of the register (Byte 3FFH), it will reset to 000H, the command is completed by driving CS# high.

Address	A23-A16	A15-A10	A9-A0
Security Register	00000000	000000	Address

GD25Q16CxIGx 3.3V Uniform Sector Dual and Quad Serial Flash

Figure 35. Read Security Registers command Sequence Diagram

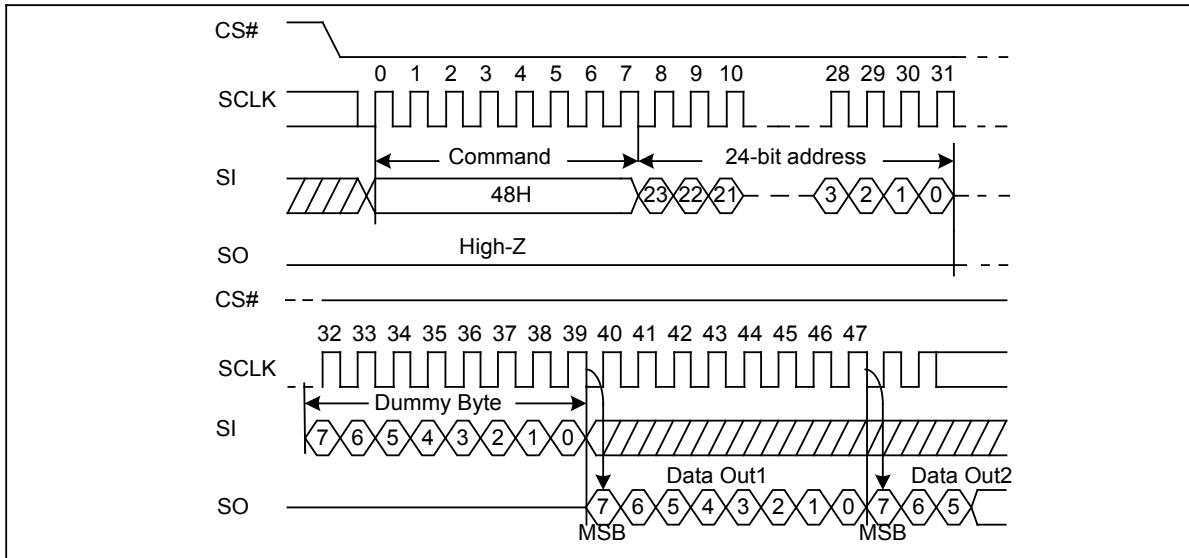

7.31. Enable Reset (66H) and Reset (99H)

If the Reset command is accepted, any on-going internal operation will be terminated and the device will return to its default power-on state and lose all the current volatile settings, such as Volatile Status Register bits, Write Enable Latch status (WEL), Program/Erase Suspend status, Read Parameter setting (P7-P0), Continuous Read Mode bit setting (M7-M0) and Wrap Bit Setting (W6-W4).

The “Reset (99H)” command sequence as follow: CS# goes low → Sending Enable Reset command → CS# goes high → CS# goes low → Sending Reset command → CS# goes high. Once the Reset command is accepted by the device, the device will take approximately $t_{RST}=60\mu s$ to reset. During this period, no command will be accepted. Data corruption may happen if there is an on-going or suspended internal Erase or Program operation when Reset command sequence is accepted by the device. It is recommended to check the BUSY bit and the SUS bit in Status Register before issuing the Reset command sequence.

Figure 36. Enable Reset and Reset command Sequence Diagram

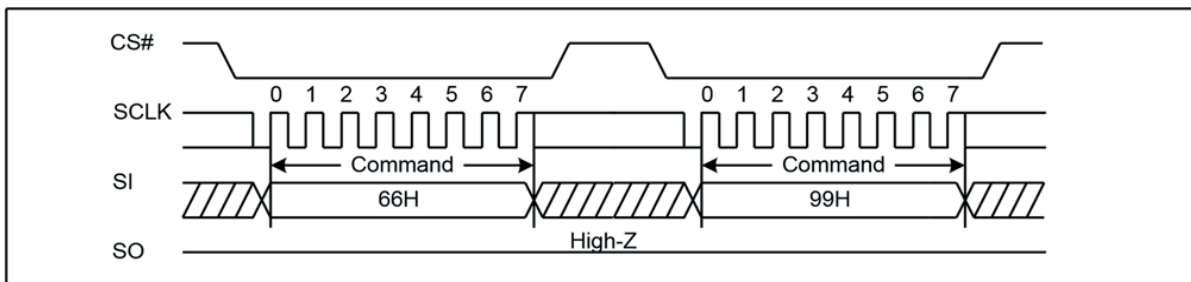

GD25Q16CxIGx 3.3V Uniform Sector Dual and Quad Serial Flash

7.32. Read Serial Flash Discoverable Parameter (5AH)

The Serial Flash Discoverable Parameter (SFDP) standard provides a consistent method of describing the functional and feature capabilities of serial flash devices in a standard set of internal parameter tables. These parameter tables can be interrogated by host system software to enable adjustments needed to accommodate divergent features from multiple vendors. The concept is similar to the one found in the Introduction of JEDEC Standard, JESD68 on CFI. SFDP is a standard of JEDEC Standard No.216.

Figure 37. Read Serial Flash Discoverable Parameter command Sequence Diagram

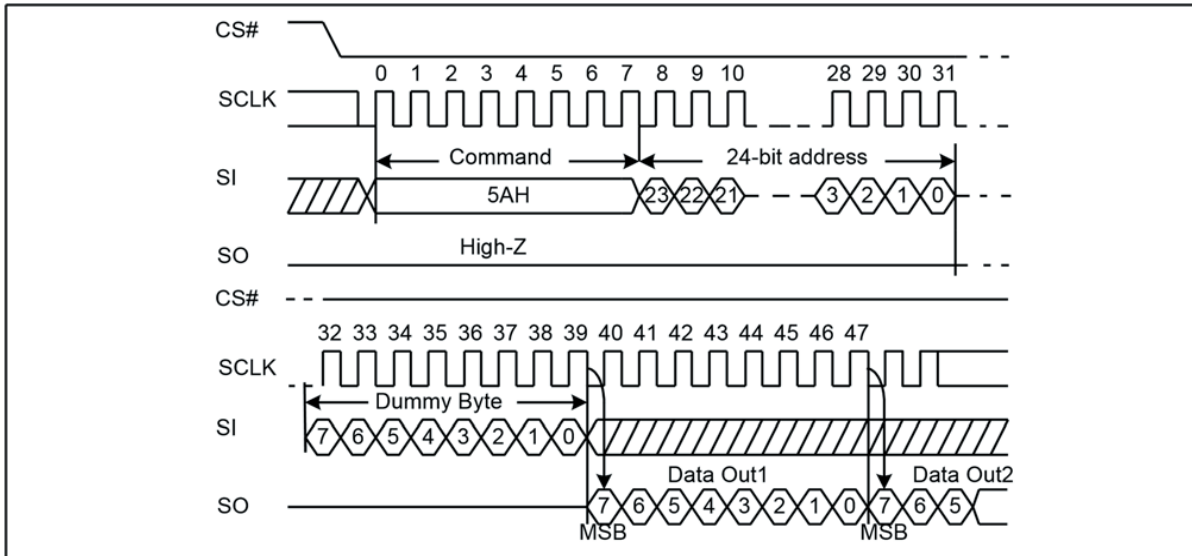

GD25Q16CxIGx 3.3V Uniform Sector Dual and Quad Serial Flash

<http://www.elm-tech.com>

Table3. Signature and Parameter Identification Data Values

Description	Comment	Add(H) (Byte)	DW Add (Bit)	Data	Data
SFDP Signature	Fixed:50444653H	00H	07:00	53H	53H
		01H	15:08	46H	46H
		02H	23:16	44H	44H
		03H	31:24	50H	50H
SFDF Minor Revision Number	Start from 00H	04H	07:00	00H	00H
SFDF Major Revision Number	Start from 01H	05H	15:08	01H	01H
Number of Parameters Headers	Start from 00H	06H	23:16	01H	01H
Unused	Contains 0×FFH and can never be changed	07H	31:24	FFH	FFH
ID number (JEDEC)	00H: It indicates a JEDEC specified header	08H	07:00	00H	00H
Parameter Table Minor Revision Number	Start from 0×00H	09H	15:08	00H	00H
Parameter Table Major Revision Number	Start from 0×01H	0AH	23:16	01H	01H
Parameter Table Length (in double word)	How many DWORDs in the Parameter Table	0BH	31:24	09H	09H
Parameter Table Pointer (PTP)	Fist address of JEDEC Flash Parameter Table	0CH	07:00	30H	30H
		0DH	15:08	00H	00H
		0EH	23:16	00H	00H
Unused	Contains 0×FFH and can never be changed	0FH	31:24	FFH	FFH
ID Number (ELM Manufacturer ID)	It is indicates ELM manufacturer ID	10H	07:00	C8H	C8H
Parameter Table Minor Revision Number	Start from 0×00H	11H	15:08	00H	00H
Parameter Table Major Revision Number	Start from 0×01H	12H	23:16	01H	01H
Parameter Table Length (in double word)	How many DWORDs in the Parameter Table	13H	31:24	03H	03H
Parameter Table Pointer (PTP)	Fist address of ELM Flash Parameter Table	14H	07:00	60H	60H
		15H	15:08	00H	00H
		16H	23:16	00H	00H
Unused	Contains 0×FFH and can never be changed	17H	31:24	FFH	FFH

GD25Q16CxIGx 3.3V Uniform Sector Dual and Quad Serial Flash

<http://www.elm-tech.com>

Table4. Parameter Table (0): JEDEC Flash Parameter Tables

Description	Comment	Add(H) (Byte)	DW Add (Bit)	Data	Data
Block/Sector Erase Size	00: Reserved; 01: 4KB erase; 10: Reserved; 11: not support 4KB erase	30H	01:00	01b	E5H
Write Granularity	0: 1Byte, 1: 64Byte or larger		02	1b	
Write Enable Instruction Requested for Writing to Volatile Status Registers	0: Nonvolatile status bit 1: Volatile status bit (BP status register bit)		03	0b	
Write Enable Opcode Select for Writing to Volatile Status Registers	0: Use 50H Opcode, 1: Use 06H Opcode, Note: If target flash status register is Nonvolatile, then bits 3 and 4 must be set to 00b.		04	0b	
Unused	Contains 111b and can never be changed		07:05	111b	
4KB Erase Opcode		31H	15:08	20H	20H
(1-1-2) Fast Read	0=Not support, 1=Support	32H	16	1b	F1H
Address Bytes Number used in addressing flash array	00: 3Byte only, 01: 3 or 4Byte, 10: 4Byte only, 11: Reserved		18:17	00b	
Double Transfer Rate (DTR) clocking	0=Not support, 1=Support		19	0b	
(1-2-2) Fast Read	0=Not support, 1=Support		20	1b	
(1-4-4) Fast Read	0=Not support, 1=Support		21	1b	
(1-1-4) Fast Read	0=Not support, 1=Support		22	1b	
Unused			23	1b	
Unused		33H	31:24	FFH	FFH
Flash Memory Density		37H:34H	31:00	00FFFFFFH	
(1-4-4) Fast Read Number of Wait states	00000b: Wait states (Dummy Clocks) not support	38H	04:00	00100b	44H
(1-4-4) Fast Read Number of Mode Bits	000b: Mode Bits not support		07:05	010b	
(1-4-4) Fast Read Opcode		39H	15:08	EBH	EBH
(1-1-4) Fast Read Number of Wait states	00000b: Wait states (Dummy Clocks) not support	3AH	20:16	01000b	08H
(1-1-4) Fast Read Number of Mode Bits	000b: Mode Bits not support		23:21	000b	
(1-1-4) Fast Read Opcode		3BH	31:24	6BH	6BH
(1-1-2) Fast Read Number of Wait states	00000b: Wait states (Dummy Clocks) not support	3CH	04:00	01000b	08H
(1-1-2) Fast Read Number of Mode Bits	000b: Mode Bits not support		07:05	000b	
(1-1-2) Fast Read Opcode		3DH	15:08	3BH	3BH

GD25Q16CxIGx 3.3V Uniform Sector Dual and Quad Serial Flash

<http://www.elm-tech.com>

Description	Comment	Add(H) (Byte)	DW Add (Bit)	Data	Data
(1-2-2) Fast Read Number of Wait states	00000b: Wait states (Dummy Clocks) not support	3EH	20:16	00010b	42H
(1-2-2) Fast Read Number of Mode Bits	000b: Mode Bits not support		23:21	010b	
(1-2-2) Fast Read Opcode		3FH	31:24	BBH	BBH
(2-2-2) Fast Read	0=not support; 1=support	40H	00	0b	EEH
Unused			03:01	111b	
(4-4-4) Fast Read	0=not support; 1=support		04	0b	
Unused			07:05	111b	
Unused		43H:41H	31:08	0×FFH	0×FFH
Unused		45H:44H	15:00	0×FFH	0×FFH
(2-2-2) Fast Read Number of Wait states	00000b: Wait states (Dummy Clocks) not support	46H	20:16	00000b	00H
(2-2-2) Fast Read Number of Mode Bits	000b: Mode Bits not support		23:21	000b	
(2-2-2) Fast Read Opcode		47H	31:24	FFH	FFH
Unused		49H:48H	15:00	0×FFH	0×FFH
(4-4-4) Fast Read Number of Wait states	00000b: Wait states (Dummy Clocks) not support	4AH	20:16	00000b	00H
(4-4-4) Fast Read Number of Mode Bits	000b: Mode Bits not support		23:21	000b	
(4-4-4) Fast Read Opcode		4BH	31:24	FFH	FFH
Sector Type 1 Size	Sector/block size=2 ^N bytes 0×00b: this sector type don't exist	4CH	07:00	0CH	0CH
Sector Type 1 erase Opcode		4DH	15:08	20H	20H
Sector Type 2 Size	Sector/block size=2 ^N bytes 0×00b: this sector type don't exist	4EH	23:16	0FH	0FH
Sector Type 2 erase Opcode		4FH	31:24	52H	52H
Sector Type 3 Size	Sector/block size=2 ^N bytes 0×00b: this sector type don't exist	50H	07:00	10H	10H
Sector Type 3 erase Opcode		51H	15:08	D8H	D8H
Sector Type 4 Size	Sector/block size=2 ^N bytes 0×00b: this sector type don't exist	52H	23:16	00H	00H
Sector Type 4 erase Opcode		53H	31:24	FFH	FFH

GD25Q16CxIGx 3.3V Uniform Sector Dual and Quad Serial Flash

<http://www.elm-tech.com>

Table5. Parameter Table (1): ELM Flash Parameter Tables

Description	Comment	Add(H) (Byte)	DW Add (Bit)	Data	Data	
Vcc Supply Maximum Voltage	2000H=2.000V 2700H=2.700V 3600H=3.600V	61H:60H	15:00	3600H	3600H	
Vcc Supply Minimum Voltage	1650H=1.650V 2250H=2.250V 2300H=2.300V 2700H=2.700V	63H:62H	31:16	2700H	2700H	
HW Reset# pin	0=not support; 1=support	65H:64H	00	0b	799EH	
HW Hold# pin	0=not support; 1=support		01	1b		
Deep Power Down Mode	0=not support; 1=support		02	1b		
SW Reset	0=not support; 1=support		03	1b		
SW Reset Opcode	Should be issue Reset Enable(66H) before Reset cmd.		11:04	99H		
Program Suspend/Resume	0=not support; 1=support		12	1b		
Erase Suspend/Resume	0=not support; 1=support		13	1b		
Unused			14	1b		
Wrap-Around Read mode	0=not support; 1=support		15	0b		
Wrap-Around Read mode Opcode			66H	23:16		FFH
Wrap-Around Read data length	08H: support 8B wrap-around read 16H: 8B & 16B 32H: 8B & 16B & 32B 64H: 8B & 16B & 32B & 64B	67H	31:24	64H	64H	
Individual block lock	0=not support; 1=support	6BH:68H	00	0b	EBFCH	
Individual block lock bit (Volatile/Nonvolatile)	0=Volatile; 1=Nonvolatile		01	0b		
Individual block lock Opcode			09:02	FFH		
Individual block lock Volatile protect bit default protect status	0=protect; 1=unprotect		10	0b		
Secured OTP	0=not support; 1=support		11	1b		
Read Lock	0=not support; 1=support		12	0b		
Permanent Lock	0=not support; 1=support		13	1b		
Unused			15:14	11b		
Unused			31:16	FFFFH		FFFFH

GD25Q16CxIGx 3.3V Uniform Sector Dual and Quad Serial Flash

8. ELECTRICAL CHARACTERISTICS

8.1. Power-On Timing

Figure 38. Power-on Timing Sequence Diagram

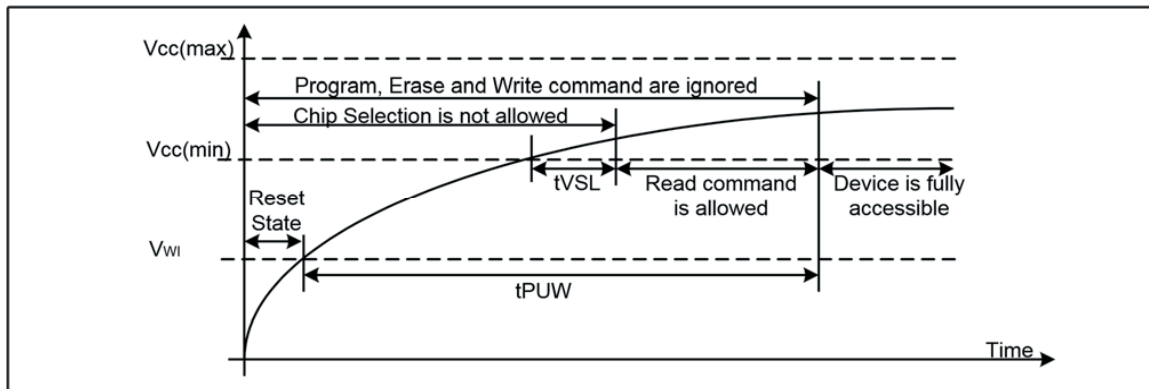

Table6. Power-Up Timing and Write Inhibit Threshold

Symbol	Parameter	Min	Typ	Max	Unit
tVSL	VCC(min) To CS# Low	10			us
tPUW	Time Delay Before Write Instruction	1		10	ms
VWI	Write Inhibit Voltage	2.1	2.3	2.5	V

8.2. Initial Delivery State

The device is delivered with the memory array erased: all bits are set to 1 (each byte contains FFH). The Status Register contains 00H (all Status Register bits are 0).

8.3. Data Retention And Endurance

Parameter	Test Condition	Min	Unit
Minimum Pattern Data Retention Time	150°C	10	Years
	125°C	20	Years
Erase/Program Endurance	-40 to 85°C	100K	Cycles

GD25Q16CxIGx 3.3V Uniform Sector Dual and Quad Serial Flash

<http://www.elm-tech.com>

8.4. Absolute Maximum Ratings

Parameter	Value	Unit
Ambient Operating Temperature	-40 to 85	°C
Storage Temperature	-65 to 150	°C
Output Short Circuit Current	200	mA
Applied Input/Output Voltage	-0.6 to VCC+4.0	V
Transient Input/Output Voltage	-2.0 to VCC+2.0	V
VCC	-0.6 to VCC+4.0	V

Figure 39. Maximum Negative/positive Overshoot Diagram

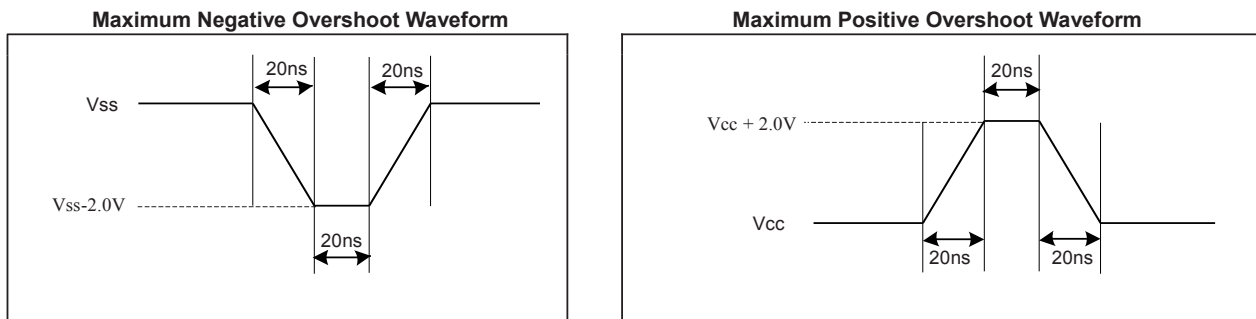

8.5. Capacitance Measurement Conditions

Symbol	Parameter	Min	Typ	Max	Unit	Conditions
CIN	Input Capacitance			6	pF	VIN=0V
COUT	Output Capacitance			8	pF	VOUT=0V
CL	Load Capacitance	30			pF	
	Input Rise And Fall time			5	ns	
	Input Pulse Voltage	0.1VCC to 0.8VCC			V	
	Input Timing Reference Voltage	0.2VCC to 0.7VCC			V	
	Output Timing Reference Voltage	0.5VCC			V	

Figure 40. Input Test Waveform and Measurement Level Diagram

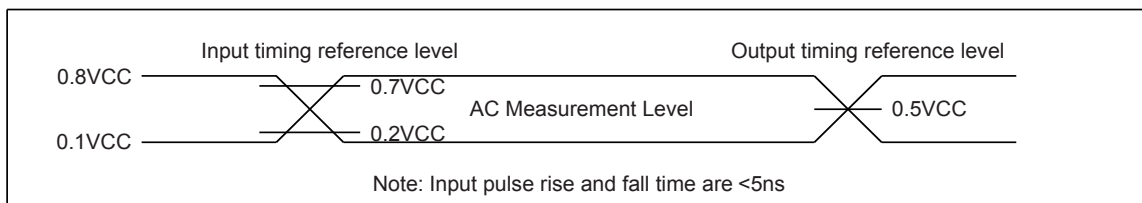

GD25Q16CxIGx 3.3V Uniform Sector Dual and Quad Serial Flash

<http://www.elm-tech.com>

8.6. DC Characteristics

(T= -40°C~85°C, VCC=2.7~3.6V)

Symbol	Parameter	Test Condition	Min.	Typ.	Max.	Unit.
ILI	Input Leakage Current				±2	μA
ILO	Output Leakage Current				±2	μA
ICC1	Standby Current	CS#=VCC, VIN=VCC or VSS		1	5	μA
ICC2	Deep Power-Down Current	CS#=VCC, VIN=VCC or VSS		1	5	μA
ICC3	Operating Current (Read)	CLK=0.1VCC/0.9VCC at 120MHz, Q=Open(*1,*2,*4 I/O)		15	20	mA
		CLK=0.1VCC/0.9VCC at 80MHz, Q=Open(*1,*2,*4 I/O)		13	18	mA
ICC4	Operating Current (PP)	CS#=VCC			20	mA
ICC5	Operating Current (WRSR)	CS#=VCC			20	mA
ICC6	Operating Current (SE)	CS#=VCC			20	mA
ICC7	Operating Current (BE)	CS#=VCC			20	mA
ICC8	Operating Current (CE)	CS#=VCC			20	mA
ICC9	High Performance Current			400	800	μA
VIL	Input Low Voltage				0.2VCC	V
VIH	Input High Voltage		0.7VCC			V
VOL	Output Low Voltage	IOL=100μA			0.2	V
VOH	Output High Voltage	IOH=-100μA	VCC-0.2			V

8.7. AC Characteristics

(T= -40°C~85°C, VCC=2.7~3.6V, CL=30pf)

Symbol	Parameter	Min.	Typ.	Max.	Unit.
fc	Serial Clock Frequency For: Dual I/O(BBH), Quad I/O(EBH), Quad Output(6BH) (Dual I/O & Quad I/O Without High Performance Mode), on 3.0V-3.6V power supply	DC.		104	MHz
fc1	Serial Clock Frequency For: Dual I/O(BBH), Quad I/O(EBH), Quad Output(6BH) (Dual I/O & Quad I/O Without High Performance Mode), on 2.7V-3.0V power supply	DC.		80	MHz
fc2	Serial Clock Frequency For: Dual I/O(BBH), Quad I/O(EBH), Quad Output(6BH) (Dual I/O & Quad I/O With High Performance Mode), on 2.7V-3.6V power supply	DC.		120	MHz
fr	Serial Clock Frequency For: Read (03H)	DC.		80	MHz
tCLH	Serial Clock High Time	4			ns
tCLL	Serial Clock Low Time	4			ns
tCLCH	Serial Clock Rise Time (Slew Rate)	0.2			V/ns
tCHCL	Serial Clock Fall Time (Slew Rate)	0.2			V/ns
tSLCH	CS# Active Setup Time	5			ns
tCHSH	CS# Active Hold Time	5			ns

GD25Q16CxIGx 3.3V Uniform Sector Dual and Quad Serial Flash

<http://www.elm-tech.com>

Symbol	Parameter	Min.	Typ.	Max.	Unit.
tSHCH	CS# Not Active Setup Time	5			ns
tCHSL	CS# Not Active Hold Time	5			ns
tSHSL	CS# High Time (Read/Write)	20			ns
tSHQZ	Output Disable Time			6	ns
tCLQX	Output Hold Time	1.2			ns
tDVCH	Data In Setup Time	2			ns
tCHDX	Data In Hold Time	2			ns
tHLCH	Hold# Low Setup Time (Relative to Clock)	5			ns
tHHCH	Hold# High Setup Time (Relative to Clock)	5			ns
tCHHL	Hold# High Hold Time (Relative to Clock)	5			ns
tCHHH	Hold# Low Hold Time (Relative to Clock)	5			ns
tHLQZ	Hold# Low To High-Z Output			6	ns
tHHQX	Hold# High To Low-Z Output			6	ns
tCLQV	Clock Low To Output Valid			7	ns
tWHSL	Write Protect Setup Time Before CS# Low	20			ns
tSHWL	Write Protect Hold Time After CS# High	100			ns
tDP	CS# High To Deep Power-Down Mode			20	μs
tRES1	CS# High To Standby Mode Without Electronic Signature Read			20	μs
tRES2	CS# High To Standby Mode With Electronic Signature Read			20	μs
tsUS	CS# High To Next Command After Suspend			20	μs
trST	CS# High To Next Command After Reset			20	μs
tw	Write Status Register Cycle Time		5	30	ms
tBP1	Byte Program Time (First Byte)		30	50	μs
tBP2	Additional Byte Program Time (After First Byte)		2.5	12	μs
tPP	Page Programming Time		0.6	2.4	ms
tSE	Sector Erase Time (4K Bytes)		45	150/300(1)	ms
tBE1	Block Erase Time (32K Bytes)		0.15	0.3/0.7(2)	s
tBE2	Block Erase Time (64K Bytes)		0.25	0.5/0.8(3)	s
tCE	Chip Erase Time (GD25Q16C)		7	20	s

Note:

- (1). Max Value 4KB t_{SE} with <50K cycles is 150ms and >50K & <100k cycles is 300ms.
- (2). Max Value 32KB t_{BE} with <50K cycles is 0.3s and >50K & <100k cycles is 0.7s.
- (3). Max Value 64KB t_{BE} with <50K cycles is 0.5s and >50K & <100k cycles is 0.8s.

GD25Q16CxIGx 3.3V Uniform Sector Dual and Quad Serial Flash

<http://www.elm-tech.com>

Figure41. Serial Input Timing Diagram

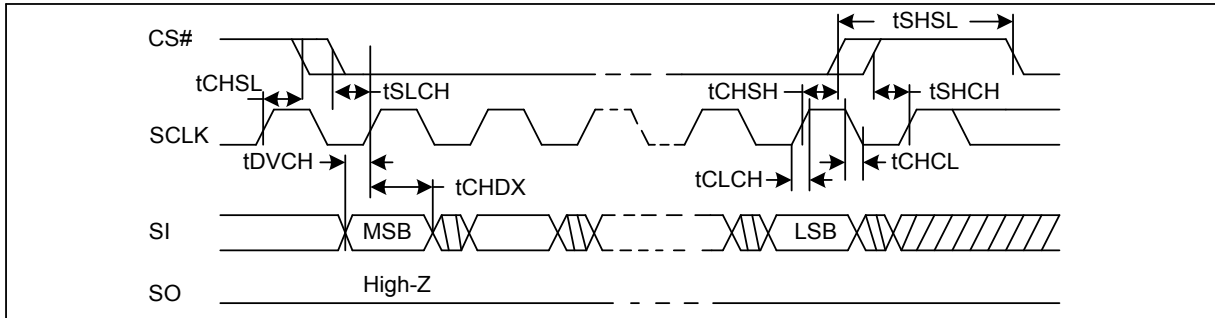

Figure42. Output Timing Diagram

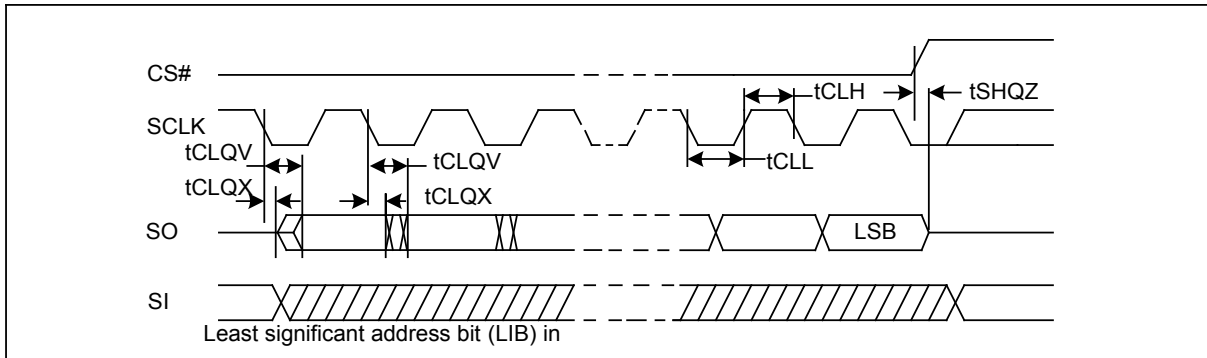
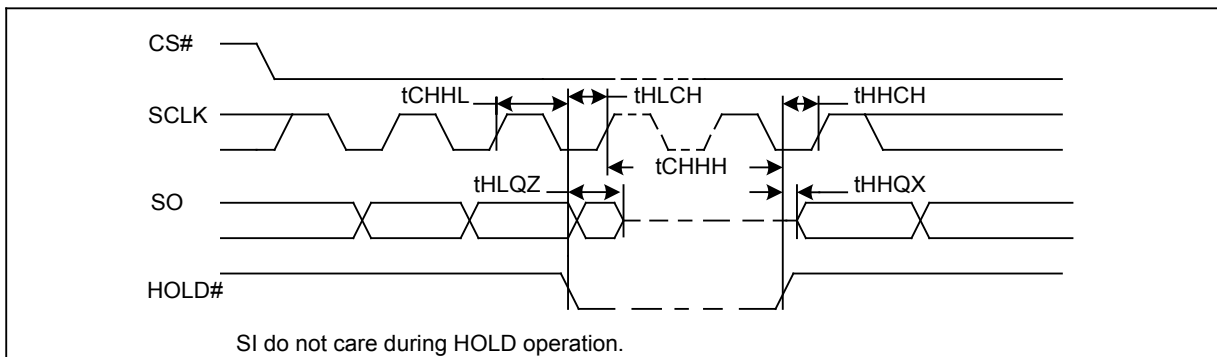

Figure43. Hold Timing Diagram



GD25Q16CxIGx 3.3V Uniform Sector Dual and Quad Serial Flash

<http://www.elm-tech.com>

9. ORDERING INFORMATION

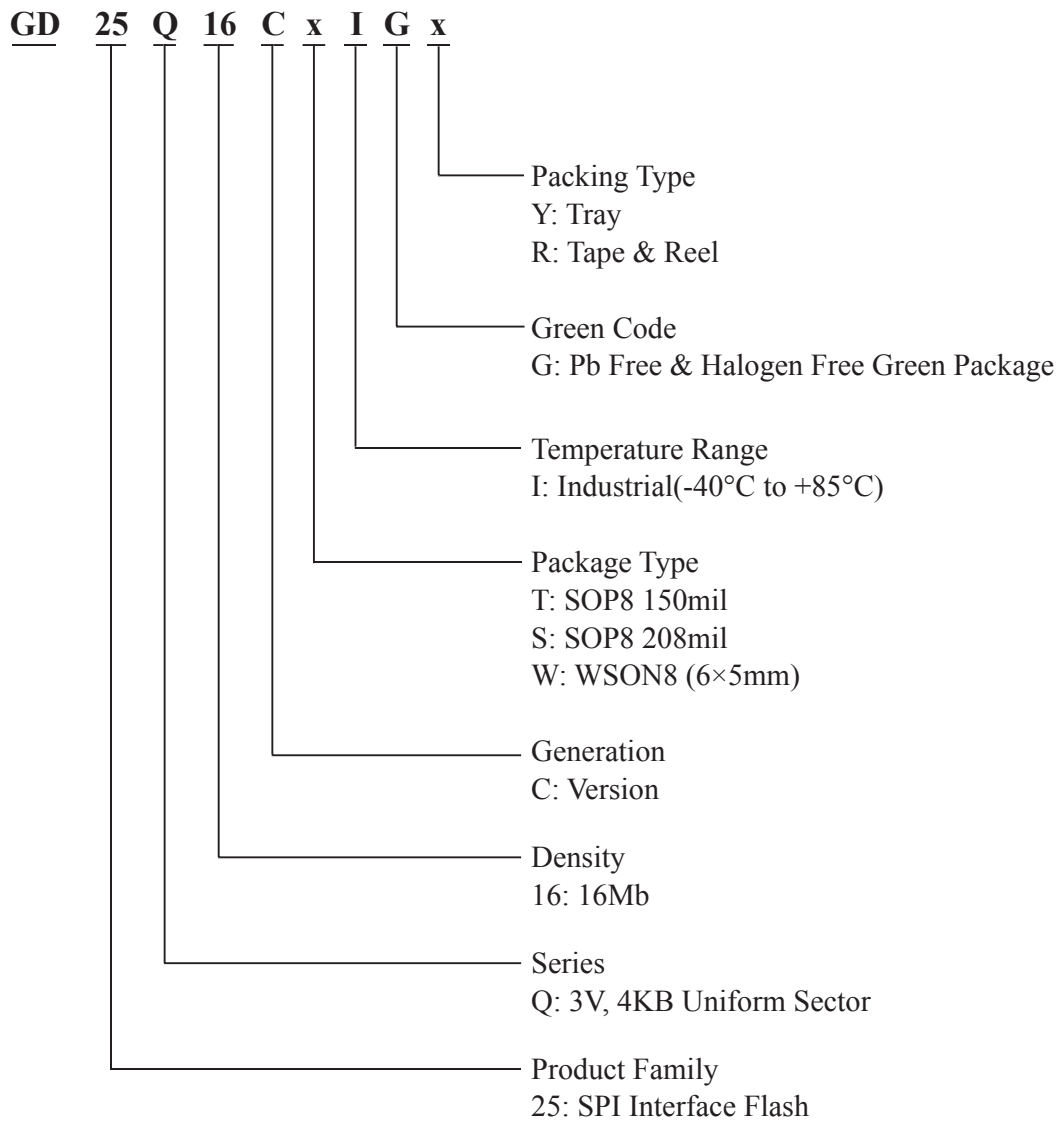

GD25Q16CxIGx 3.3V Uniform Sector Dual and Quad Serial Flash

<http://www.elm-tech.com>

10. PACKAGE INFORMATION

10.1. Package SOP8 150MIL

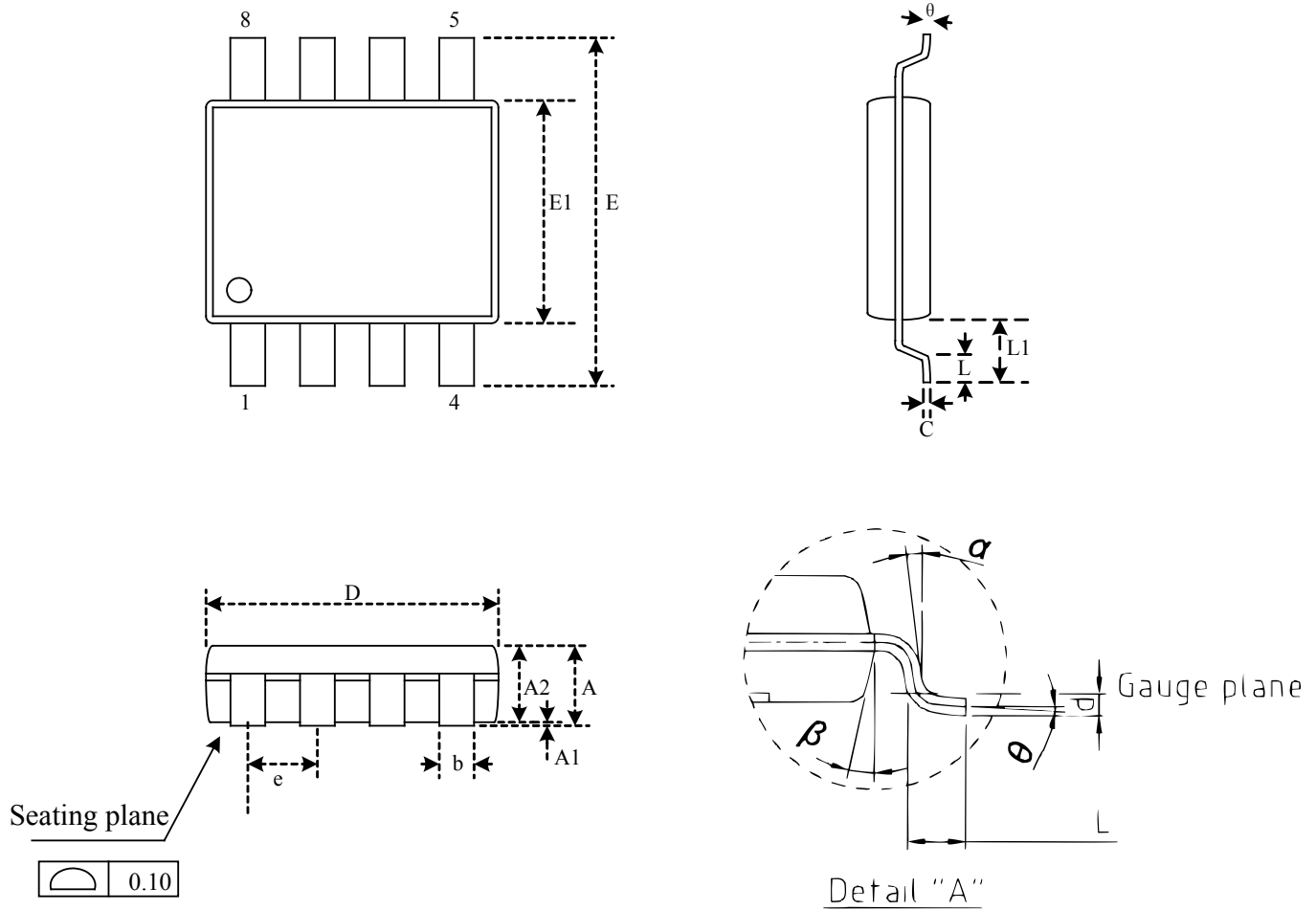

Dimensions

Symbol		A	A1	A2	b	c	D	E	E1	e	L	L1	θ	α	β
Unit															
mm	Min	1.35	0.05	1.35	0.31	0.15	4.77	5.80	3.80	-	0.40	0.85	0°	6°	11°
	Nom	-	-	-	-	-	4.90	6.00	3.90	1.27	-	1.06	-	7°	12°
	Max	1.75	0.25	1.55	0.51	0.25	5.03	6.20	4.00	-	0.90	1.27	8°	8°	13°
Inch	Min	0.053	0.002	0.053	0.012	0.006	0.188	0.228	0.149	-	0.016	0.033	0°	6°	11°
	Nom	-	-	-	0.016	-	0.193	0.236	0.154	0.050	0	0.042	-	7°	12°
	Max	0.069	0.010	0.061	0.020	0.010	0.198	0.244	0.158	-	0.035	0.050	8°	8°	13°

Note: Both package length and width do not include mold flash.

GD25Q16CxIGx 3.3V Uniform Sector Dual and Quad Serial Flash

<http://www.elm-tech.com>

10.2. Package SOP8 208MIL

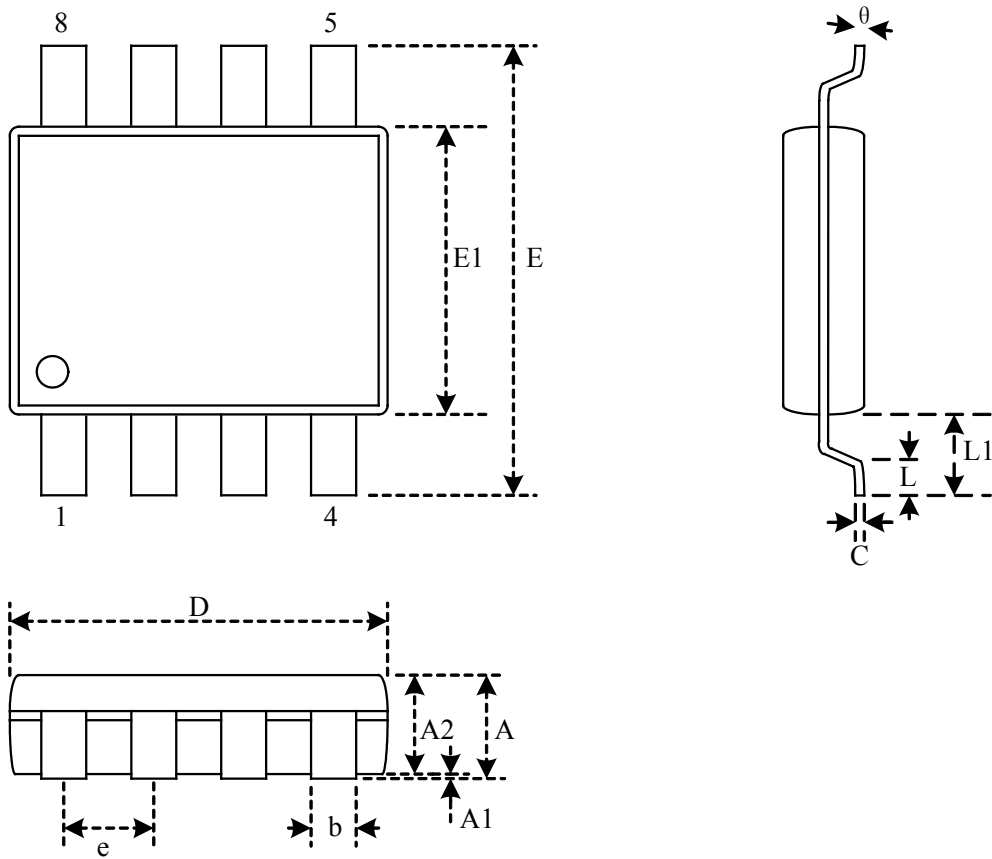

Dimensions

Symbol		A	A1	A2	b	c	D	E	E1	e	L	L1	θ
Unit													
mm	Min	-	0.05	1.70	0.31	0.18	5.13	7.70	5.18	-	0.50	1.21	0°
	Nom	-	0.15	1.80	0.41	0.21	5.23	7.90	5.28	1.27BSC	0.67	1.31	5°
	Max	2.16	0.25	1.91	0.51	0.25	5.33	8.10	5.38	-	0.85	1.41	8°
Inch	Min	-	0.002	0.067	0.012	0.007	0.202	0.303	0.204	-	0.020	0.048	0°
	Nom	-	0.006	0.071	0.016	0.008	0.206	0.311	0.208	0.050BSC	0.026	0.052	5°
	Max	0.085	0.010	0.075	0.020	0.010	0.210	0.319	0.212	-	0.033	0.056	8°

Note: Both package length and width do not include mold flash.

GD25Q16CxIGx 3.3V Uniform Sector Dual and Quad Serial Flash

<http://www.elm-tech.com>

10.3. Package WSON8 (6×5mm)

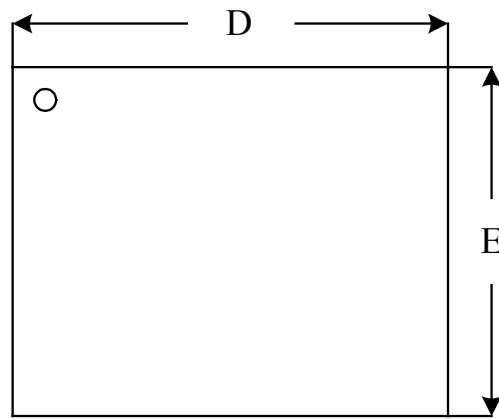

Top View

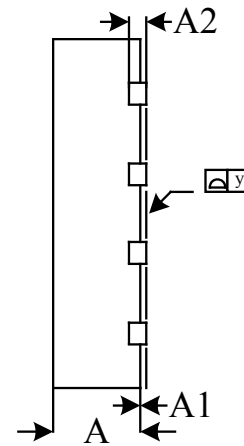

Side View

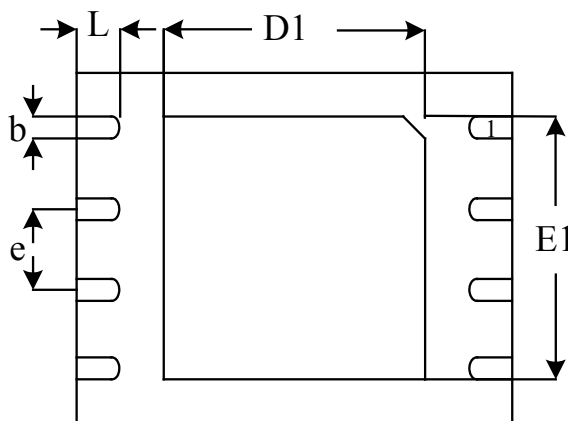

Bottom View

Dimensions

Symbol		A	A1	A2	b	D	D1	E	E1	e	y	L
Unit												
mm	Min	0.70	-	0.19	0.35	5.90	3.25	4.90	3.85	-	0.00	0.50
	Nom	0.75	-	0.22	0.42	6.00	3.37	5.00	3.97	1.27 BSC	0.04	0.60
	Max	0.80	0.05	0.25	0.48	6.10	3.50	5.10	4.10	-	0.08	0.75
Inch	Min	0.028	-	0.007	0.014	0.232	0.128	0.193	0.151	-	0.000	0.020
	Nom	0.030	-	0.009	0.016	0.236	0.133	0.197	0.156	0.05 BSC	0.001	0.024
	Max	0.032	0.002	0.010	0.019	0.240	0.138	0.201	0.161	-	0.003	0.030

Note:

1. Both package length and width do not include mold flash.
2. The exposed metal pad area on the bottom of the package is connected to device ground (GND pin), so both Floating and connecting GND of exposed pad are also available.