

Federkontakte am Band
spring contact on carrier strip

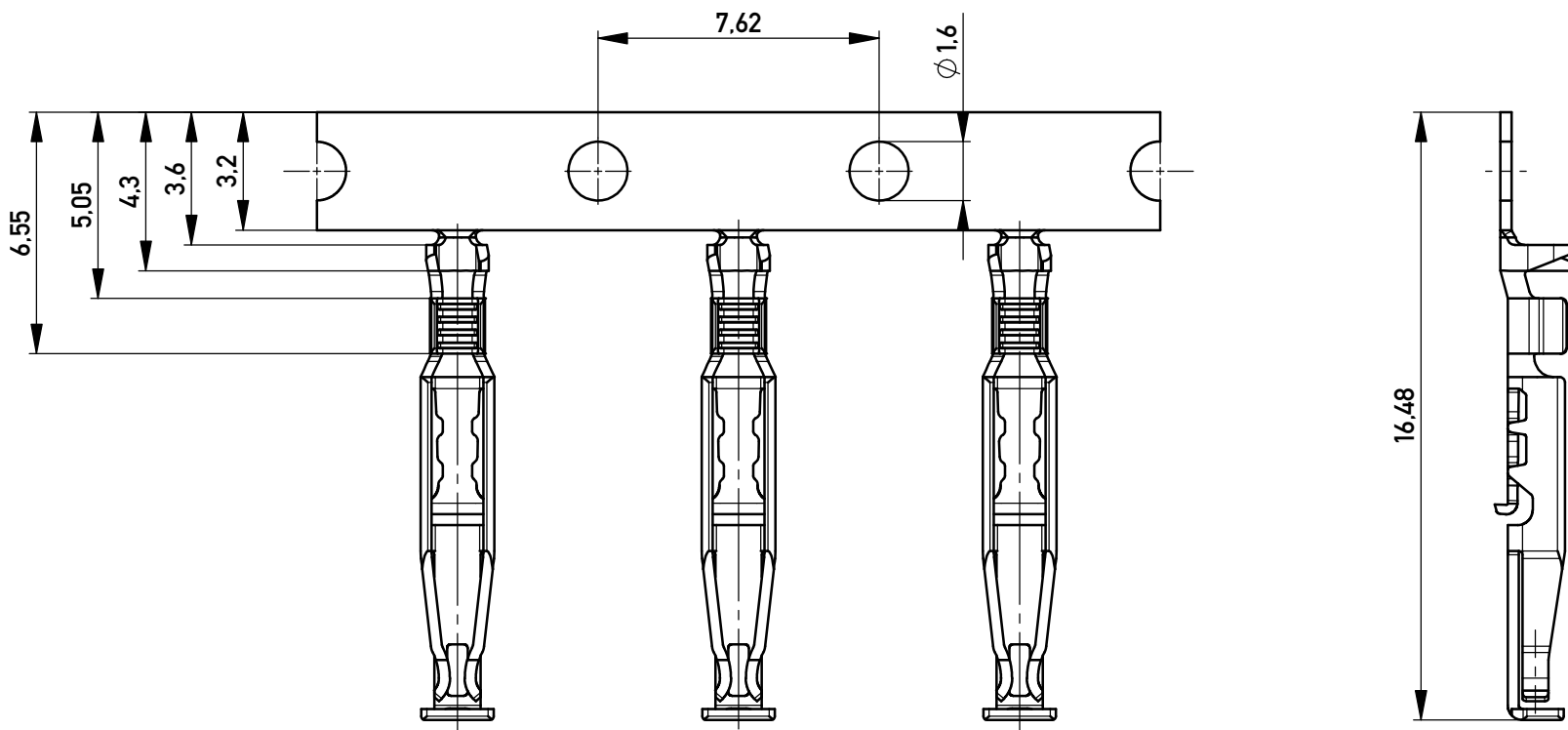

Federkontakt vereinzelt
spring contact isolated

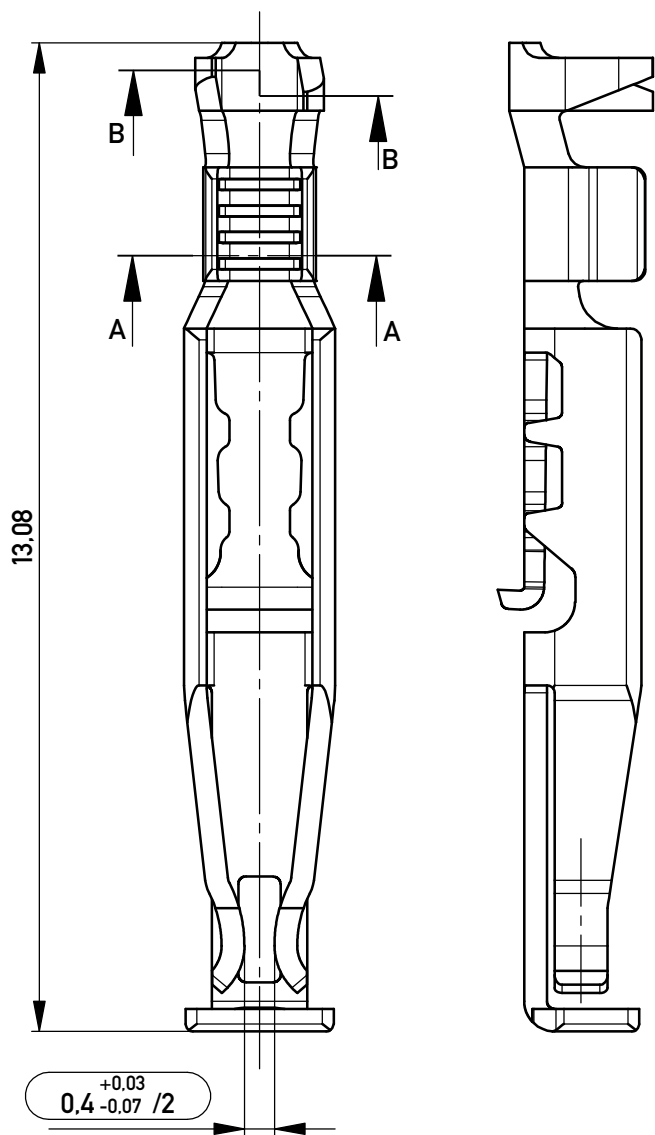

Schnitt A-A
cross section A-A

M 10:1

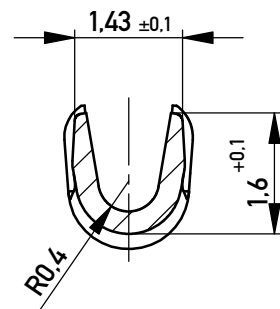

Drahtcrimp
wire crimp

Schnitt B-B
cross section B-B

M 10:1

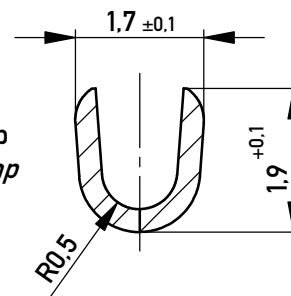

Isolationscrimp
insulation crimp

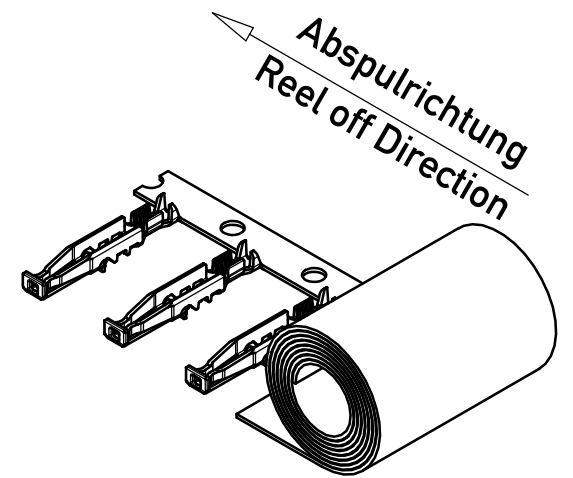

SPC-Maß: Prüfmerkmale der Kategorie /1

/1 Für SPC-Maße muss eine x/s Regelkarte geführt werden mit Nachweis der Prozessfähigkeit in der Serie (Cpk) oder 100% - Prüfung

Prüfmerkmal: Prüfmerkmale der Kategorie /2 und /3

/2 Für Prüfmerkmale muss eine x/s Regelkarte geführt werden

/3 Prüfmerkmale werden serienbegleitend geprüft

AWG 24-26	500	∅ 130	137	
Leiterquerschnitt wire cross section	Menge quantity	Spulendurchmesser reel diameter	Anforderungsstufe class	Bemerkung remark

Information:		Tolerances	Scale 2:1
All rights reserved. Only for Information. To ensure that this is the latest version of this drawing, please contact one of the ERNI companies before using.		All Dimensions in mm	
Subject to modification without prior notice. Drawing will not be updated.		Designation Federkontakte 2,54 SRC-A BA 2 <i>spring contact 2,54 SRC-A</i>	
ERNI www.ERNI.com		106302070001	
b	12.06.2015	K	
Index	Date	A3	
Class		SRCROL	

Copyright by ERNI Production GmbH & Co. KG
Proprietary notice pursuant to ISO 16016 to be observed.