

TMP300 1.8V, Resistor-Programmable Temperature Switch and Analog Out Temperature Sensor in SC70

1 Features

- Accuracy: $\pm 1^\circ\text{C}$ (Typical at $+25^\circ\text{C}$)
- Programmable Trip Point
- Programmable Hysteresis: $5^\circ\text{C}/10^\circ\text{C}$
- Open-Drain Outputs
- Low Power: $110\mu\text{A}$ (Max)
- Wide Voltage Range: $+1.8\text{V}$ to $+18\text{V}$
- Temperature Range: -40°C to $+125^\circ\text{C}$
- Analog Out: $10\text{mV}/^\circ\text{C}$
- SC70-6 and SOT23-6 Packages

2 Applications

- Power-supply Systems
- DC-DC Modules
- Thermal Monitoring
- Electronic Protection Systems

3 Description

The TMP300 is a low-power, resistor-programmable, digital output temperature switch. The device allows a threshold point to be set by adding an external resistor. Two levels of hysteresis are available. The TMP300 has a V_{TEMP} analog output that can be used as a testing point or in temperature-compensation loops.

With a supply voltage as low as 1.8V and low current consumption, the TMP300 is ideal for power-sensitive systems.

Available in two micropackages that have proven thermal characteristics, this part gives a complete and simple solution for users who need simple and reliable thermal management.

Device Information⁽¹⁾

PART NUMBER	PACKAGE	BODY SIZE (NOM)
TMP300	SOT-23 (6)	2.90 mm x 1.60 mm
	SC70 (6)	2.00 mm x 1.25 mm

(1) For all available packages, see the orderable addendum at the end of the data sheet.

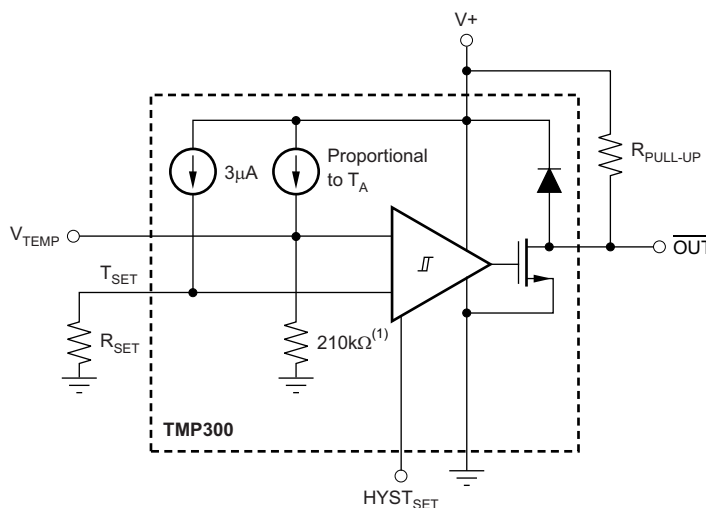
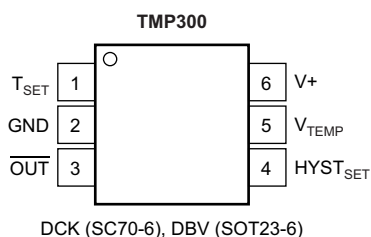

NOTE: (1) Thinfilm resistor with approximately 10% accuracy; however, this accuracy error is trimmed out at the factory.



Table of Contents

1	Features	1	6	Detailed Description	7
2	Applications	1	6.1	Overview	7
3	Description	1	6.2	Feature Description	7
4	Revision History	2	7	Device and Documentation Support	11
5	Specifications	3	7.1	Community Resources	11
5.1	Absolute Maximum Ratings	3	7.2	Trademarks	11
5.2	ESD Ratings	3	7.3	Electrostatic Discharge Caution	11
5.3	Electrical Characteristics	4	7.4	Glossary	11
5.4	Typical Characteristics	5	8	Mechanical, Packaging, and Orderable Information	11

4 Revision History

Changes from Revision C (January 2011) to Revision D	Page
• Added <i>Device Information</i> table, <i>ESD Ratings</i> table, <i>Feature Description</i> section, <i>Device and Documentation Support</i> section, and <i>Mechanical, Packaging, and Orderable Information</i> section	1
• Changed <i>Temperature Range</i> Features bullet	1
• Added package names to pinout	1
• Deleted <i>Ordering Information</i> table	3
• Changed Temperature Range, <i>TA</i> , <i>Functional Range</i> parameter name in <i>Electrical Characteristics</i> table	4
• Added footnote 4 to <i>Electrical Characteristics</i> table	4

Changes from Revision B (November 2008) to Revision C	Page
• Deleted second sentence from <i>Description</i> section	1
• Added TMP300B grade device specifications to <i>Electrical Characteristics</i> table	4

5 Specifications

5.1 Absolute Maximum Ratings⁽¹⁾

		MIN	MAX	UNIT
V+	Supply voltage		+18	V
	Signal input pins, voltage ⁽²⁾	–0.5	(V+) + 0.5	V
	Signal input pins, current ⁽²⁾	–10	10	mA
I _{SC}	Output short-circuit ⁽³⁾	Continuous		
	Open-drain output		(V+) + 0.5	V
T _A	Functional temperature	–40	+150	°C
T _{stg}	Storage temperature	–55	+150	°C
T _J	Junction temperature		+150	°C

- (1) Stresses beyond those listed under *Absolute Maximum Ratings* may cause permanent damage to the device. These are stress ratings only, which do not imply functional operation of the device at these or any other conditions beyond those indicated under *Recommended Operating Conditions*. Exposure to absolute-maximum-rated conditions for extended periods may affect device reliability.
- (2) Input pins are diode-clamped to the power-supply rails. Input signals that can swing more than 0.5V beyond the supply rails should be current limited to 10mA or less.
- (3) Short-circuit to ground.

5.2 ESD Ratings

			VALUE	UNIT
V _(ESD)	Electrostatic discharge	Human-body model (HBM)	±4000	V
		Charged-device model (CDM)	±1000	

TMP300

SBOS335D – JUNE 2005 – REVISED JANUARY 2016

www.ti.com

5.3 Electrical Characteristics

At $V_S = 3.3V$ and $T_A = -40^\circ C$ to $+125^\circ C$, unless otherwise noted.

PARAMETER	TEST CONDITIONS	TMP300			TMP300B			UNIT	
		MIN ⁽¹⁾	TYP ⁽¹⁾	MAX ⁽¹⁾	MIN	TYP	MAX		
TEMPERATURE MEASUREMENT									
Measurement range	$V_S = 2.35V$ to $18V$	-40		+125	-40		+125	°C	
	$V_S = 1.8V$ to $2.35V$	-40		$100 \times (V_S - 0.95)$	-40		$100 \times (V_S - 0.95)$		
TRIP POINT									
Total accuracy	$T_A = -40^\circ C$ to $+125^\circ C$		± 2	± 4 ⁽²⁾		± 2	± 6	°C	
R _{SET} equation	T_C is in °C		$R_{SET} = 10 (50 + T_C)/3$		$R_{SET} = 10 (50 + T_C)/3$			kΩ	
HYSTERESIS SET INPUT									
LOW threshold				0.4			0.4	V	
HIGH threshold		$V_S - 0.4$			$V_S - 0.4$			V	
Threshold hysteresis	HYST _{SET} = GND			5			5	°C	
	HYST _{SET} = V_S			10			10		
DIGITAL OUTPUT									
Logic family			CMOS		CMOS				
Open-drain leakage current	OUT = V_S			10			10	μA	
V _{OL} Logic levels	$V_S = 1.8V$ to $18V$, I _{SINK} = 5mA			0.3			0.3	V	
ANALOG OUTPUT									
Accuracy			± 2	± 3		± 2	± 5	°C	
Temperature sensitivity			10			10		mV/°C	
Output voltage	$T_A = +25^\circ C$	720	750	780	720	750	780	mV	
V _{TEMP} pin output resistance			210			210		kΩ	
POWER SUPPLY									
I _Q Quiescent current ⁽³⁾	$V_S = 1.8V$ to $18V$, $T_A = -40^\circ C$ to $+125^\circ C$			110			110	μA	
TEMPERATURE RANGE									
T _A	Specified range	$V_S = 2.35V$ to $18V$	-40		+125	-40		+125	°C
		$V_S = 1.8V$ to $2.35V$	-40		$100 \times (V_S - 0.95)$	-40		$100 \times (V_S - 0.95)$	
	Functional range ⁽⁴⁾	$V_S = 2.35V$ to $18V$	-40		+150	-40		+150	
		$V_S = 1.8V$ to $2.35V$	-50		$100 \times (V_S - 0.95)$	-50		$100 \times (V_S - 0.95)$	
θ _{JA} Thermal resistance	SC70			250			250	°C/W	
	SOT23-6			180			180		

(1) 100% of production is tested at $T_A = +85^\circ C$. Specifications over temperature range are ensured by design.

(2) Shaded cells indicate characteristic performance difference.

(3) See Figure 1 for typical quiescent current.

(4) The TMP300 is functional over this range and no indication of performance is implied.

5.4 Typical Characteristics

At $V_S = 5V$, unless otherwise noted.

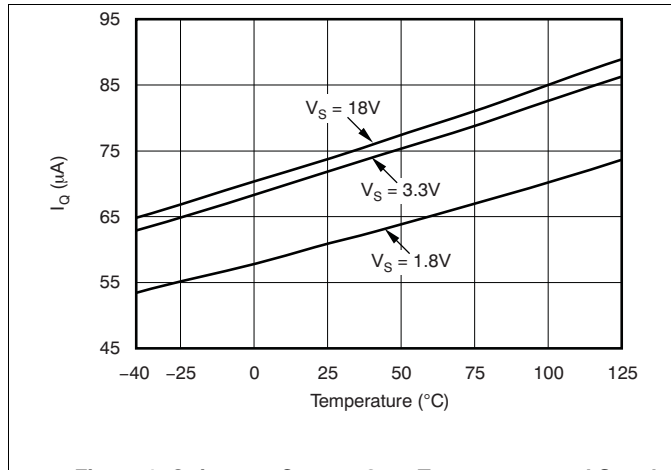

Figure 1. Quiescent Current Over Temperature and Supply

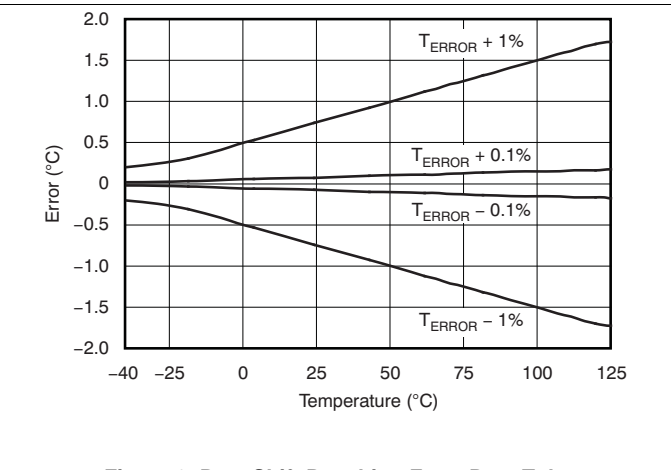

Figure 2. R_{SET} Shift Resulting From R_{SET} Tolerance

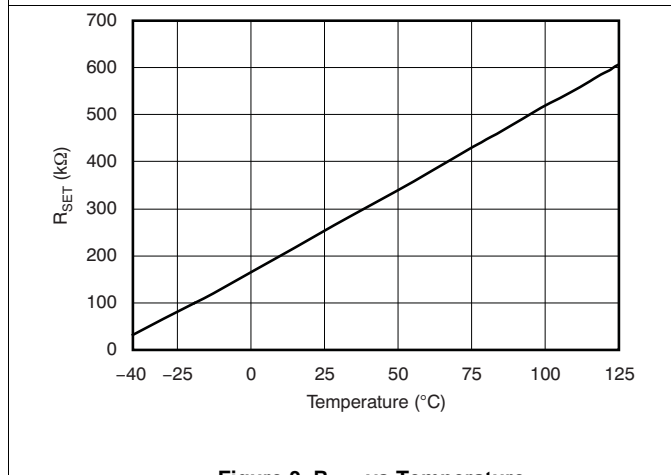

Figure 3. R_{SET} vs Temperature

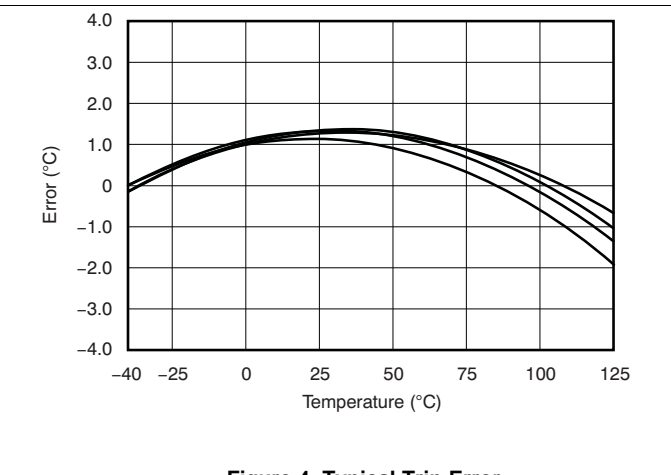

Figure 4. Typical Trip Error

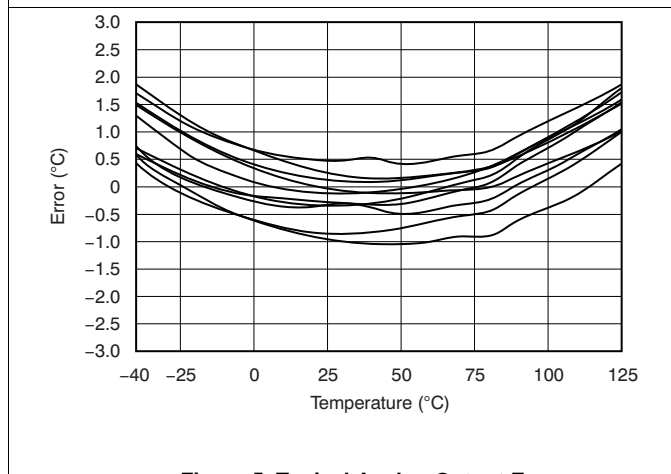

Figure 5. Typical Analog Output Error

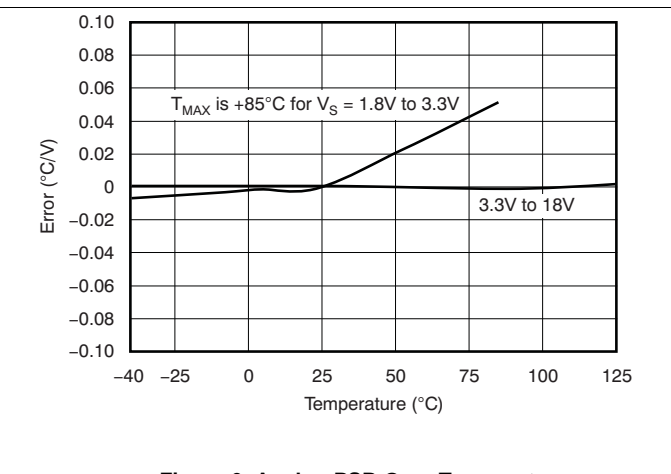

Figure 6. Analog PSR Over Temperature

Typical Characteristics (continued)

At $V_S = 5V$, unless otherwise noted.

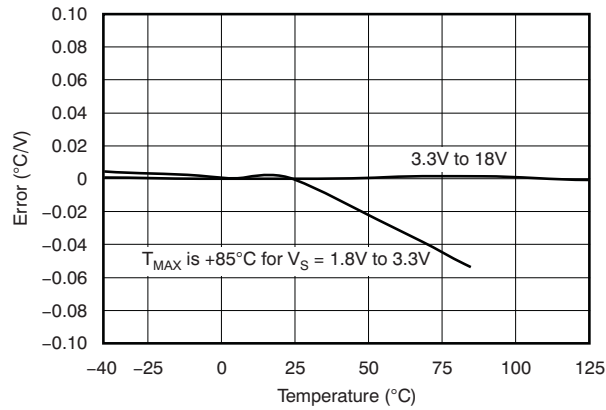

Figure 7. Trip PSR Over Temperature

6 Detailed Description

6.1 Overview

The TMP300 is a thermal sensor designed for over-temperature protection circuits in electronic systems. The TMP300 uses a set resistor to program the trip temperature of the digital output. An additional high-impedance (210kΩ) analog voltage output provides the temperature reading.

6.2 Feature Description

6.2.1 Calculating R_{SET}

The set resistor (R_{SET}) provides a threshold voltage for the comparator input. The TMP300 trips when the V_{TEMP} pin exceeds the T_{SET} voltage. The value of the set resistor is determined by the analog output function and the 3μA internal bias current.

To set the TMP300 to trip at a preset value, calculate the R_{SET} resistor value according to [Equation 1](#) or [Equation 2](#):

$$R_{SET} = \frac{(T_{SET} \times 0.01 + 0.5)}{3e^{-6}}$$

where

- T_{SET} is in °C; or (1)

$$R_{SET} \text{ in } k\Omega = \frac{10(50 + T_{SET})}{3}$$

where

- T_{SET} is in °C. (2)

6.2.2 Using V_{TEMP} to Trip the Digital Output

The analog voltage output can also serve as a voltage input that forces a trip of the digital output to simulate a thermal event. This simulation facilitates easy system design and test of thermal safety circuits, as shown in [Figure 8](#).

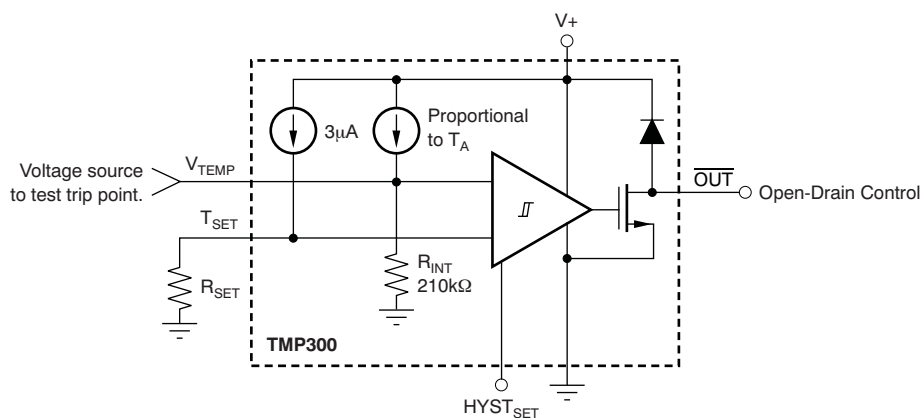

Figure 8. Applying Voltage to Trip Digital Output

Feature Description (continued)

6.2.3 Analog Temperature Output

The analog out or V_{TEMP} pin is high-impedance ($210k\Omega$). Avoid loading this pin to prevent degrading the analog out value or trip point. Buffer the output of this pin when used for direct thermal measurement. Figure 9 shows buffering of the analog output signal.

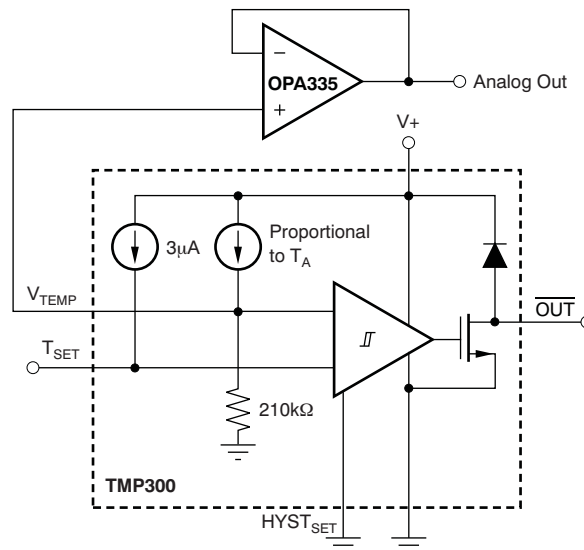

Figure 9. Buffering the Analog Output Signal

6.2.4 Using a DAC to Set the Trip Point

The trip point is easily converted by changing the digital-to-analog converter (DAC) code. This technique can be useful for control loops where a large thermal mass is being brought up to the set temperature and the \overline{OUT} pin is used to control the heating element. The analog output can be monitored in a control algorithm that adjusts the set temperature to prevent overshoot. Trip set voltage error versus temperature is shown in Figure 10, which shows error in $^{\circ}C$ of the comparator input over temperature. An alternative method of setting the trip point by using a DAC is illustrated in Figure 11.

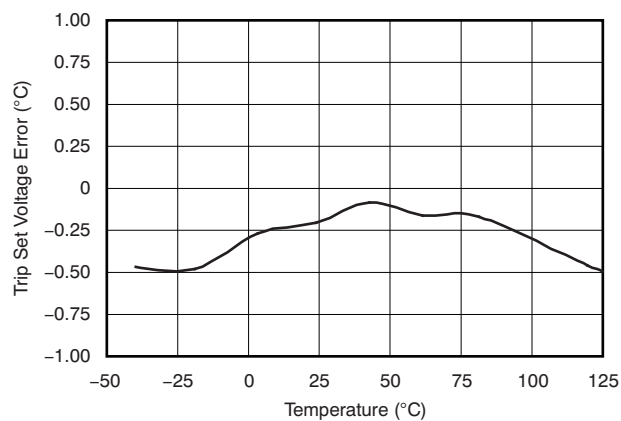

Figure 10. Trip Set Voltage Error vs Temperature

Feature Description (continued)

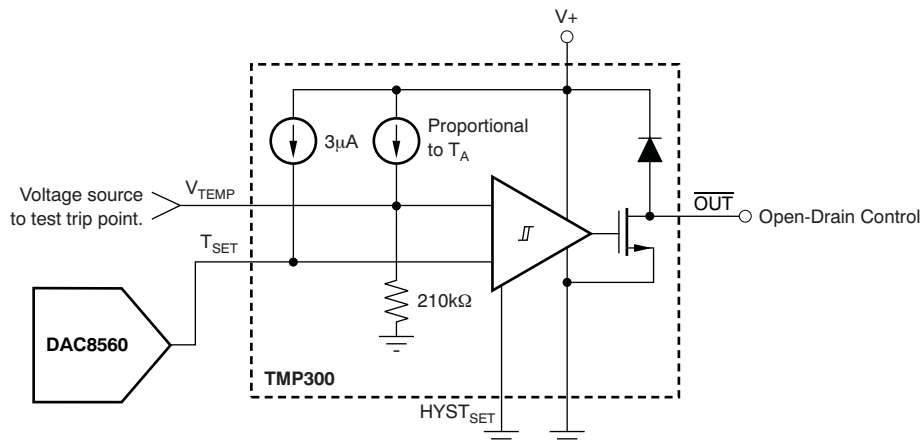
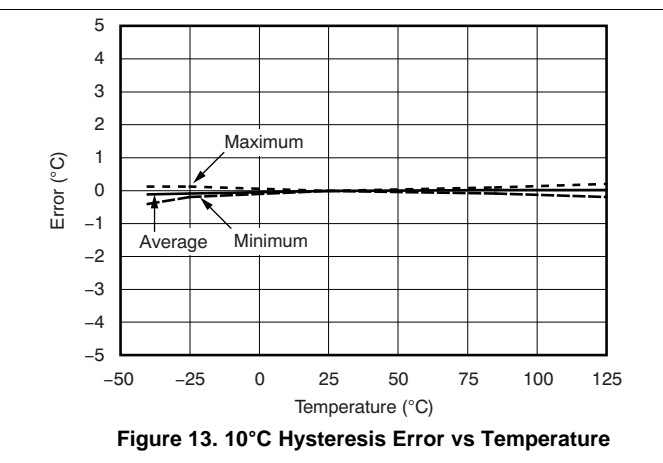
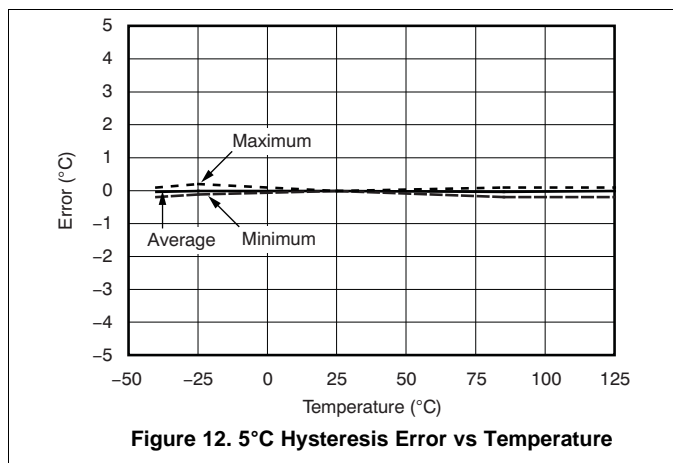

Figure 11. DAC Generates the Voltage-Driving T_{SET} Pin

6.2.5 Hysteresis

The hysteresis pin has two settings. Grounding HYST_{SET} results in 5°C of hysteresis. Connecting HYST_{SET} to V_S results in 10°C of hysteresis. Hysteresis error variation over temperature is shown in Figure 12 and Figure 13.



Feature Description (continued)

Use bypass capacitors on the supplies as well as on the R_{SET} and analog out (V_{TEMP}) pins when in noisy environments, as shown in Figure 14. These capacitors reduce premature triggering of the comparator.

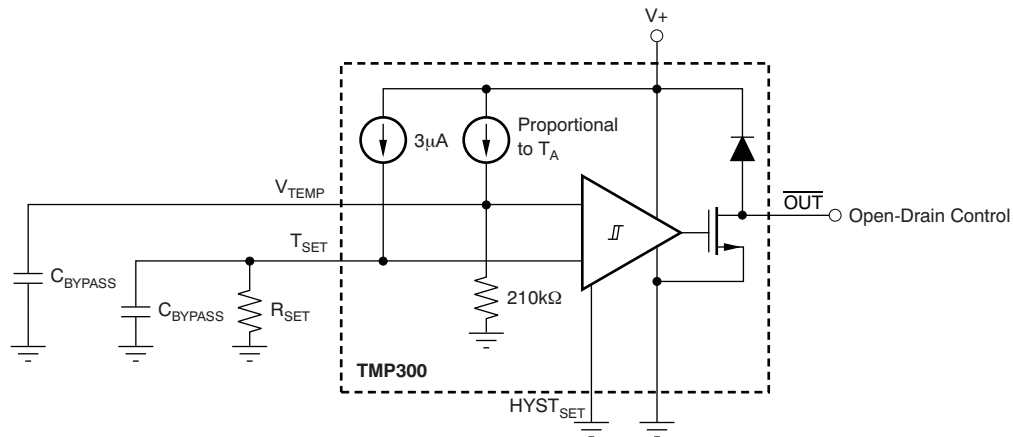

Figure 14. Bypass Capacitors Prevent Early Comparator Toggling Due to Circuit Board Noise

7 Device and Documentation Support

7.1 Community Resources

The following links connect to TI community resources. Linked contents are provided "AS IS" by the respective contributors. They do not constitute TI specifications and do not necessarily reflect TI's views; see TI's [Terms of Use](#).

TI E2E™ Online Community *TI's Engineer-to-Engineer (E2E) Community*. Created to foster collaboration among engineers. At e2e.ti.com, you can ask questions, share knowledge, explore ideas and help solve problems with fellow engineers.

Design Support *TI's Design Support* Quickly find helpful E2E forums along with design support tools and contact information for technical support.

7.2 Trademarks

E2E is a trademark of Texas Instruments.
All other trademarks are the property of their respective owners.

7.3 Electrostatic Discharge Caution



These devices have limited built-in ESD protection. The leads should be shorted together or the device placed in conductive foam during storage or handling to prevent electrostatic damage to the MOS gates.

7.4 Glossary

[SLYZ022](#) — *TI Glossary*.

This glossary lists and explains terms, acronyms, and definitions.

8 Mechanical, Packaging, and Orderable Information

The following pages include mechanical, packaging, and orderable information. This information is the most current data available for the designated devices. This data is subject to change without notice and revision of this document. For browser-based versions of this data sheet, refer to the left-hand navigation.

PACKAGING INFORMATION

Orderable Device	Status (1)	Package Type	Package Drawing	Pins	Package Qty	Eco Plan (2)	Lead/Ball Finish (6)	MSL Peak Temp (3)	Op Temp (°C)	Device Marking (4/5)	Samples
TMP300AIDBVR	NRND	SOT-23	DBV	6	3000	Green (RoHS & no Sb/Br)	CU NIPDAU	Level-1-260C-UNLIM	-40 to 125	T300	
TMP300AIDBVT	NRND	SOT-23	DBV	6	250	Green (RoHS & no Sb/Br)	CU NIPDAU	Level-1-260C-UNLIM	-40 to 125	T300	
TMP300AIDCKR	NRND	SC70	DCK	6	3000	Green (RoHS & no Sb/Br)	CU NIPDAU	Level-1-260C-UNLIM	-40 to 125	BPN	
TMP300AIDCKRG4	NRND	SC70	DCK	6	3000	Green (RoHS & no Sb/Br)	CU NIPDAU	Level-1-260C-UNLIM	-40 to 125	BPN	
TMP300AIDCKT	NRND	SC70	DCK	6	250	Green (RoHS & no Sb/Br)	CU NIPDAU	Level-1-260C-UNLIM	-40 to 125	BPN	
TMP300AIDCKTG4	NRND	SC70	DCK	6	250	Green (RoHS & no Sb/Br)	CU NIPDAU	Level-1-260C-UNLIM	-40 to 125	BPN	
TMP300BIDBVR	ACTIVE	SOT-23	DBV	6	3000	Green (RoHS & no Sb/Br)	CU NIPDAU	Level-1-260C-UNLIM	-40 to 125	DUDC	Samples
TMP300BIDBVT	ACTIVE	SOT-23	DBV	6	250	Green (RoHS & no Sb/Br)	CU NIPDAU	Level-1-260C-UNLIM	-40 to 125	DUDC	Samples
TMP300BIDCKR	ACTIVE	SC70	DCK	6	3000	Green (RoHS & no Sb/Br)	CU NIPDAU	Level-1-260C-UNLIM	-40 to 125	QWL	Samples
TMP300BIDCKT	ACTIVE	SC70	DCK	6	250	Green (RoHS & no Sb/Br)	CU NIPDAU	Level-1-260C-UNLIM	-40 to 125	QWL	Samples

(1) The marketing status values are defined as follows:

ACTIVE: Product device recommended for new designs.

LIFEBUY: TI has announced that the device will be discontinued, and a lifetime-buy period is in effect.

NRND: Not recommended for new designs. Device is in production to support existing customers, but TI does not recommend using this part in a new design.

PREVIEW: Device has been announced but is not in production. Samples may or may not be available.

OBSELETE: TI has discontinued the production of the device.

(2) Eco Plan - The planned eco-friendly classification: Pb-Free (RoHS), Pb-Free (RoHS Exempt), or Green (RoHS & no Sb/Br) - please check <http://www.ti.com/productcontent> for the latest availability information and additional product content details.

TBD: The Pb-Free/Green conversion plan has not been defined.

Pb-Free (RoHS): TI's terms "Lead-Free" or "Pb-Free" mean semiconductor products that are compatible with the current RoHS requirements for all 6 substances, including the requirement that lead not exceed 0.1% by weight in homogeneous materials. Where designed to be soldered at high temperatures, TI Pb-Free products are suitable for use in specified lead-free processes.

Pb-Free (RoHS Exempt): This component has a RoHS exemption for either 1) lead-based flip-chip solder bumps used between the die and package, or 2) lead-based die adhesive used between the die and leadframe. The component is otherwise considered Pb-Free (RoHS compatible) as defined above.

Green (RoHS & no Sb/Br): TI defines "Green" to mean Pb-Free (RoHS compatible), and free of Bromine (Br) and Antimony (Sb) based flame retardants (Br or Sb do not exceed 0.1% by weight in homogeneous material)

- (3) MSL, Peak Temp. - The Moisture Sensitivity Level rating according to the JEDEC industry standard classifications, and peak solder temperature.
- (4) There may be additional marking, which relates to the logo, the lot trace code information, or the environmental category on the device.
- (5) Multiple Device Markings will be inside parentheses. Only one Device Marking contained in parentheses and separated by a "~" will appear on a device. If a line is indented then it is a continuation of the previous line and the two combined represent the entire Device Marking for that device.
- (6) Lead/Ball Finish - Orderable Devices may have multiple material finish options. Finish options are separated by a vertical ruled line. Lead/Ball Finish values may wrap to two lines if the finish value exceeds the maximum column width.

Important Information and Disclaimer:The information provided on this page represents TI's knowledge and belief as of the date that it is provided. TI bases its knowledge and belief on information provided by third parties, and makes no representation or warranty as to the accuracy of such information. Efforts are underway to better integrate information from third parties. TI has taken and continues to take reasonable steps to provide representative and accurate information but may not have conducted destructive testing or chemical analysis on incoming materials and chemicals. TI and TI suppliers consider certain information to be proprietary, and thus CAS numbers and other limited information may not be available for release.

In no event shall TI's liability arising out of such information exceed the total purchase price of the TI part(s) at issue in this document sold by TI to Customer on an annual basis.

OTHER QUALIFIED VERSIONS OF TMP300 :

- Automotive: [TMP300-Q1](#)

NOTE: Qualified Version Definitions:

- Automotive - Q100 devices qualified for high-reliability automotive applications targeting zero defects

TAPE AND REEL INFORMATION



QUADRANT ASSIGNMENTS FOR PIN 1 ORIENTATION IN TAPE



*All dimensions are nominal

Device	Package Type	Package Drawing	Pins	SPQ	Reel Diameter (mm)	Reel Width W1 (mm)	A0 (mm)	B0 (mm)	K0 (mm)	P1 (mm)	W (mm)	Pin1 Quadrant
TMP300AIDBVR	SOT-23	DBV	6	3000	179.0	8.4	3.2	3.2	1.4	4.0	8.0	Q3
TMP300AIDBVT	SOT-23	DBV	6	250	179.0	8.4	3.2	3.2	1.4	4.0	8.0	Q3
TMP300AIDCKR	SC70	DCK	6	3000	179.0	8.4	2.2	2.5	1.2	4.0	8.0	Q3
TMP300AIDCKT	SC70	DCK	6	250	179.0	8.4	2.2	2.5	1.2	4.0	8.0	Q3
TMP300BIDBVR	SOT-23	DBV	6	3000	179.0	8.4	3.2	3.2	1.4	4.0	8.0	Q3
TMP300BIDBVT	SOT-23	DBV	6	250	179.0	8.4	3.2	3.2	1.4	4.0	8.0	Q3
TMP300BIDCKR	SC70	DCK	6	3000	179.0	8.4	2.2	2.5	1.2	4.0	8.0	Q3
TMP300BIDCKT	SC70	DCK	6	250	179.0	8.4	2.2	2.5	1.2	4.0	8.0	Q3

TAPE AND REEL BOX DIMENSIONS



*All dimensions are nominal

Device	Package Type	Package Drawing	Pins	SPQ	Length (mm)	Width (mm)	Height (mm)
TMP300AIDBVR	SOT-23	DBV	6	3000	203.0	203.0	35.0
TMP300AIDBVT	SOT-23	DBV	6	250	203.0	203.0	35.0
TMP300AIDCKR	SC70	DCK	6	3000	203.0	203.0	35.0
TMP300AIDCKT	SC70	DCK	6	250	203.0	203.0	35.0
TMP300BIDBVR	SOT-23	DBV	6	3000	203.0	203.0	35.0
TMP300BIDBVT	SOT-23	DBV	6	250	203.0	203.0	35.0
TMP300BIDCKR	SC70	DCK	6	3000	203.0	203.0	35.0
TMP300BIDCKT	SC70	DCK	6	250	203.0	203.0	35.0

MECHANICAL DATA

DBV (R-PDSO-G6)

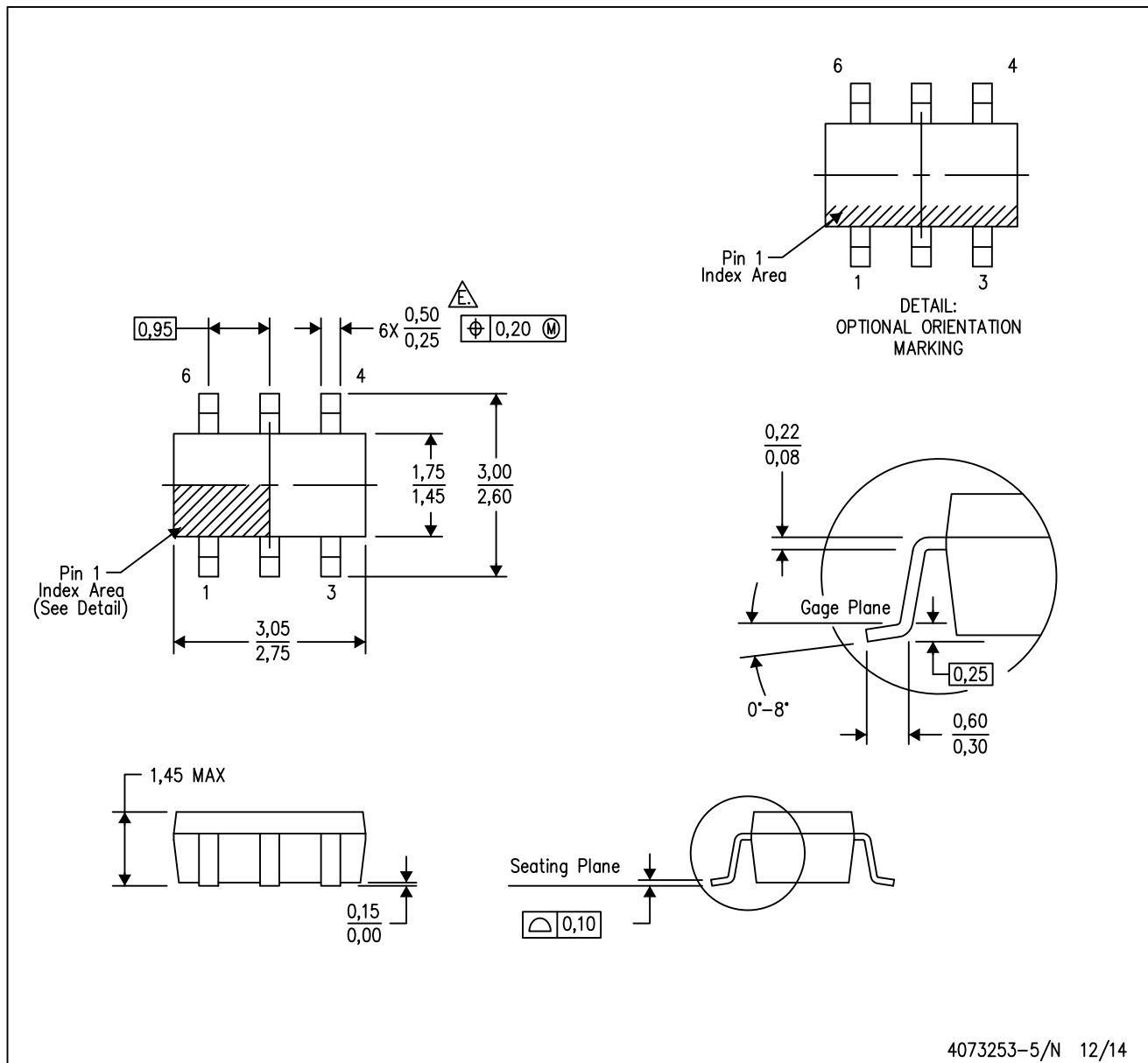
PLASTIC SMALL-OUTLINE PACKAGE



- NOTES:
- All linear dimensions are in millimeters.
 - This drawing is subject to change without notice.
 - Body dimensions do not include mold flash or protrusion. Mold flash and protrusion shall not exceed 0.15 per side.
 - Leads 1,2,3 may be wider than leads 4,5,6 for package orientation.
- Falls within JEDEC MO-178 Variation AB, except minimum lead width.

DBV (R-PDSO-G6)

PLASTIC SMALL OUTLINE

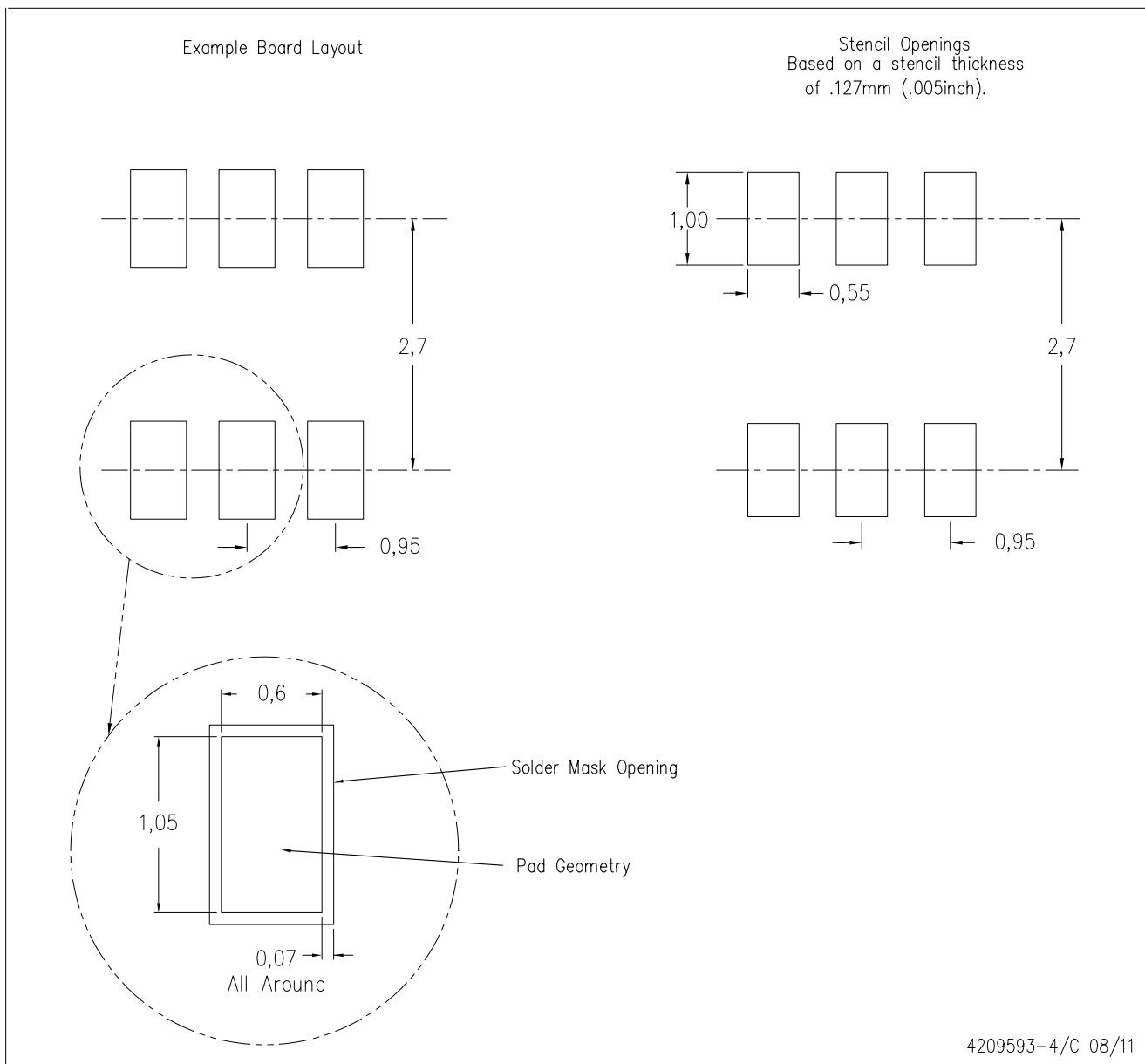

- NOTES:
- A. All linear dimensions are in millimeters.
 - B. This drawing is subject to change without notice.
 - C. Customers should place a note on the circuit board fabrication drawing not to alter the center solder mask defined pad.
 - D. Publication IPC-7351 is recommended for alternate designs.
 - E. Laser cutting apertures with trapezoidal walls and also rounding corners will offer better paste release. Customers should contact their board assembly site for stencil design recommendations. Example stencil design based on a 50% volumetric metal load solder paste. Refer to IPC-7525 for other stencil recommendations.

DCK (R-PDSO-G6)

PLASTIC SMALL-OUTLINE PACKAGE

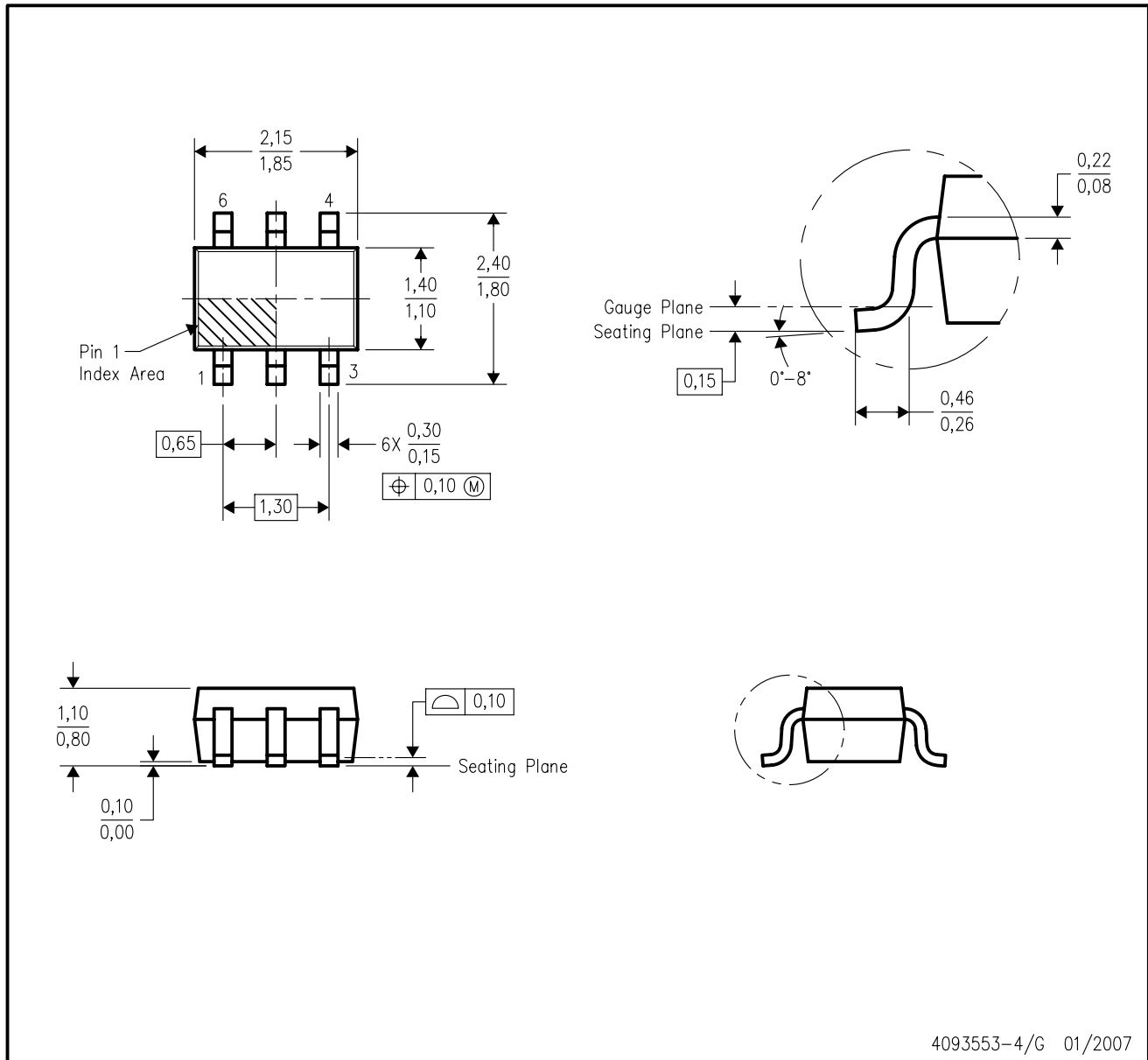

- NOTES:
- A. All linear dimensions are in millimeters.
 - B. This drawing is subject to change without notice.
 - C. Body dimensions do not include mold flash or protrusion. Mold flash and protrusion shall not exceed 0.15 per side.
 - D. Falls within JEDEC MO-203 variation AB.

DCK (R-PDSO-G6)

PLASTIC SMALL OUTLINE

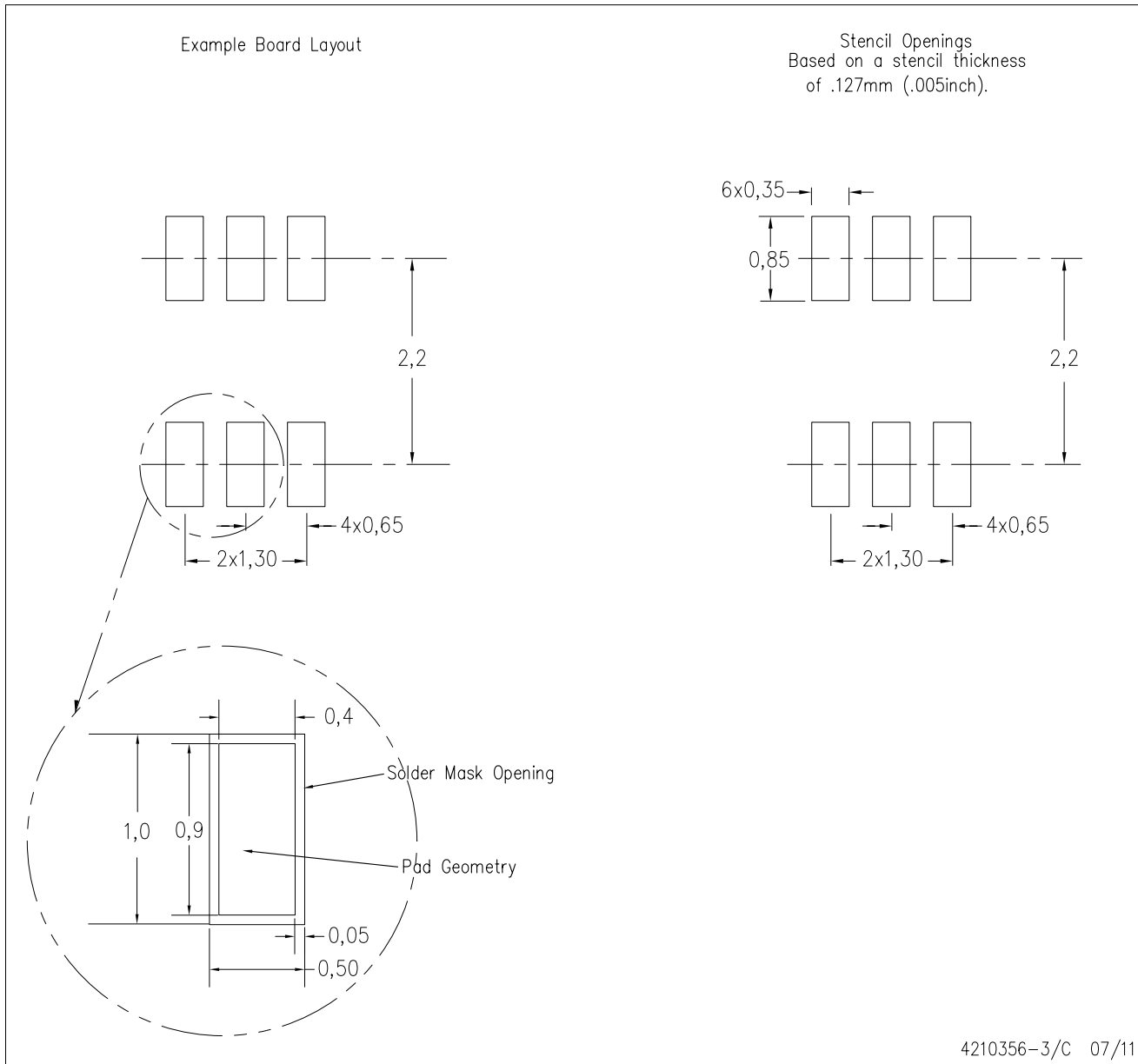

- NOTES:
- All linear dimensions are in millimeters.
 - This drawing is subject to change without notice.
 - Customers should place a note on the circuit board fabrication drawing not to alter the center solder mask defined pad.
 - Publication IPC-7351 is recommended for alternate designs.
 - Laser cutting apertures with trapezoidal walls and also rounding corners will offer better paste release. Customers should contact their board assembly site for stencil design recommendations. Example stencil design based on a 50% volumetric metal load solder paste. Refer to IPC-7525 for other stencil recommendations.

IMPORTANT NOTICE

Texas Instruments Incorporated and its subsidiaries (TI) reserve the right to make corrections, enhancements, improvements and other changes to its semiconductor products and services per JESD46, latest issue, and to discontinue any product or service per JESD48, latest issue. Buyers should obtain the latest relevant information before placing orders and should verify that such information is current and complete. All semiconductor products (also referred to herein as "components") are sold subject to TI's terms and conditions of sale supplied at the time of order acknowledgment.

TI warrants performance of its components to the specifications applicable at the time of sale, in accordance with the warranty in TI's terms and conditions of sale of semiconductor products. Testing and other quality control techniques are used to the extent TI deems necessary to support this warranty. Except where mandated by applicable law, testing of all parameters of each component is not necessarily performed.

TI assumes no liability for applications assistance or the design of Buyers' products. Buyers are responsible for their products and applications using TI components. To minimize the risks associated with Buyers' products and applications, Buyers should provide adequate design and operating safeguards.

TI does not warrant or represent that any license, either express or implied, is granted under any patent right, copyright, mask work right, or other intellectual property right relating to any combination, machine, or process in which TI components or services are used. Information published by TI regarding third-party products or services does not constitute a license to use such products or services or a warranty or endorsement thereof. Use of such information may require a license from a third party under the patents or other intellectual property of the third party, or a license from TI under the patents or other intellectual property of TI.

Reproduction of significant portions of TI information in TI data books or data sheets is permissible only if reproduction is without alteration and is accompanied by all associated warranties, conditions, limitations, and notices. TI is not responsible or liable for such altered documentation. Information of third parties may be subject to additional restrictions.

Resale of TI components or services with statements different from or beyond the parameters stated by TI for that component or service voids all express and any implied warranties for the associated TI component or service and is an unfair and deceptive business practice. TI is not responsible or liable for any such statements.

Buyer acknowledges and agrees that it is solely responsible for compliance with all legal, regulatory and safety-related requirements concerning its products, and any use of TI components in its applications, notwithstanding any applications-related information or support that may be provided by TI. Buyer represents and agrees that it has all the necessary expertise to create and implement safeguards which anticipate dangerous consequences of failures, monitor failures and their consequences, lessen the likelihood of failures that might cause harm and take appropriate remedial actions. Buyer will fully indemnify TI and its representatives against any damages arising out of the use of any TI components in safety-critical applications.

In some cases, TI components may be promoted specifically to facilitate safety-related applications. With such components, TI's goal is to help enable customers to design and create their own end-product solutions that meet applicable functional safety standards and requirements. Nonetheless, such components are subject to these terms.

No TI components are authorized for use in FDA Class III (or similar life-critical medical equipment) unless authorized officers of the parties have executed a special agreement specifically governing such use.

Only those TI components which TI has specifically designated as military grade or "enhanced plastic" are designed and intended for use in military/aerospace applications or environments. Buyer acknowledges and agrees that any military or aerospace use of TI components which have **not** been so designated is solely at the Buyer's risk, and that Buyer is solely responsible for compliance with all legal and regulatory requirements in connection with such use.

TI has specifically designated certain components as meeting ISO/TS16949 requirements, mainly for automotive use. In any case of use of non-designated products, TI will not be responsible for any failure to meet ISO/TS16949.

Products

Audio	www.ti.com/audio
Amplifiers	amplifier.ti.com
Data Converters	dataconverter.ti.com
DLP® Products	www.dlp.com
DSP	dsp.ti.com
Clocks and Timers	www.ti.com/clocks
Interface	interface.ti.com
Logic	logic.ti.com
Power Mgmt	power.ti.com
Microcontrollers	microcontroller.ti.com
RFID	www.ti-rfid.com
OMAP Applications Processors	www.ti.com/omap
Wireless Connectivity	www.ti.com/wirelessconnectivity

Applications

Automotive and Transportation	www.ti.com/automotive
Communications and Telecom	www.ti.com/communications
Computers and Peripherals	www.ti.com/computers
Consumer Electronics	www.ti.com/consumer-apps
Energy and Lighting	www.ti.com/energy
Industrial	www.ti.com/industrial
Medical	www.ti.com/medical
Security	www.ti.com/security
Space, Avionics and Defense	www.ti.com/space-avionics-defense
Video and Imaging	www.ti.com/video

TI E2E Community

e2e.ti.com