

**DESCRIPTION** The BN1L3Z is designed for use in medium speed switching circuit.

**FEATURE** • Bias resistors built-in type PNP transistor equivalent circuit.

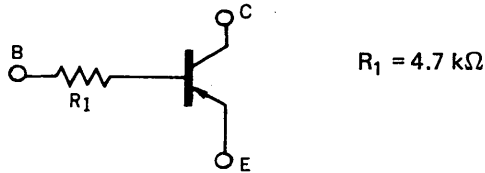

**ABSOLUTE MAXIMUM RATINGS**

- Maximum Temperatures
- Storage Temperature . . . . .  $-55$  to  $+150$  °C
  - Junction Temperature . . . . .  $150$  °C Maximum
- Maximum Power Dissipation ( $T_a = 25$  °C)
- Total Power Dissipation . . . . .  $250$  mW
- Maximum Voltages and Currents ( $T_a = 25$  °C)
- $V_{CBO}$  Collector to Base Voltage . . . . .  $-60$  V
  - $V_{CEO}$  Collector to Emitter Voltage . . . . .  $-50$  V
  - $V_{EBO}$  Emitter to Base Voltage . . . . .  $-5.0$  V
  - $I_{C(DC)}$  Collector Current (DC) . . . . .  $-100$  mA
  - $I_{C(pulse)}$  Collector Current (pulse) . . . . .  $-200$  mA

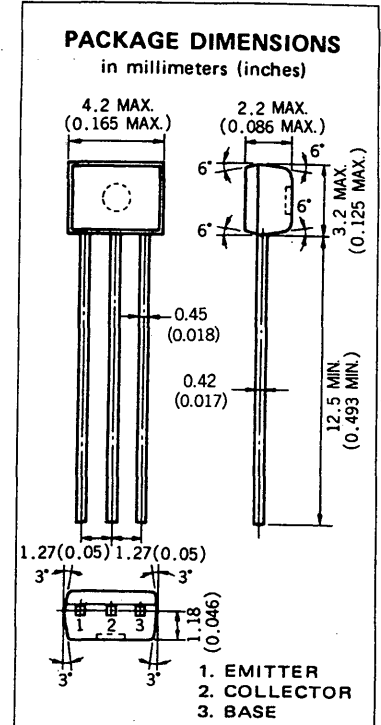

**ELECTRICAL CHARACTERISTICS ( $T_a = 25$  °C)**

SYMBOL	CHARACTERISTIC	MIN.	TYP.	MAX.	UNIT	TEST CONDITIONS
$R_1$	Input Resistance	3.29	4.7	6.11	$k\Omega$	
$V_{IL}$	Low Level Input Voltage		$-0.57$	$-0.5$	V	$V_{CE} = -5.0$ V, $I_C = -100$ $\mu$ A
$V_{IH}$	Hi Level Input Voltage	$-1.2$	$-0.75$		V	$V_{CE} = -0.2$ V, $I_C = -5.0$ mA
$t_{on}$	Turn On Time		0.04	0.2	$\mu$ s	$V_{CC} = -5.0$ V, $R_L = 1.0$ $k\Omega$ , $V_{in} = -5.0$ V, $PW = 2$ $\mu$ s, Duty Cycle $\leq 2\%$
$t_{stg}$	Storage Time		1.7	5.0	$\mu$ s	
$t_{off}$	Turn Off Time		1.9	6.0	$\mu$ s	
$h_{FE1}$	DC Current Gain	135	260	600	-	$V_{CE} = -5.0$ V, $I_C = -5.0$ mA
$h_{FE2}$	DC Current Gain	100	200		-	$V_{CE} = -5.0$ V, $I_C = -50$ mA
$V_{CE(sat)}$	Collector Saturation Voltage		$-0.04$	$-0.2$	V	$I_C = -5.0$ mA, $I_B = -0.25$ mA
$I_{CBO}$	Collector Cutoff Current			$-0.1$	$\mu$ A	$V_{CB} = -50$ V, $I_E = 0$

TYPICAL CHARACTERISTICS ( $T_a = 25^\circ\text{C}$ )

