

1.5 A LOW DROPOUT REGULATOR WITH VOLTAGE CORRECTION CIRCUIT

■ FEATURES

- Output Current 1.5 A
- Default Output Voltage Accuracy 5.1 V \pm 0.9%
- Adjustable Output Voltage 5.15 V \pm 1.2%
- Output Voltage Correction
 $V_O + 375$ mV (typ), 0 mA to 1500 mA at $R_{ADJ} = 10$ k Ω
- Internal Fixed Soft-Start 4 msec (typ)
- Error Flag Output (FAULT)
- Error Flag Output Delay for Hot Plug 1.2 msec (typ)
- ON/OFF Control
- Overcurrent Protection
- Short-Circuit Protection
- Reverse Current Prevention
- Undervoltage Lockout
- Thermal Shutdown Circuit with Hysteresis
- Package HSOP8

■ APPLICATIONS

- Car Audio / Car Navigation Systems
- Docking Stations
- USB Chargers

■ DESCRIPTION

The NJM2816 is a low dropout regulator with an internal voltage correction circuit which delivers up to 1.5 A of output current.

The voltage correction (cable drop compensation) raises the output voltage in proportion to the load current. This function corrects the voltage drop due to cable or writing board resistance.

Unique features, such as overcurrent protection, thermal shutdown, soft-start and error flag output make the NJM2816 ideal for portable devices charged with USB cable.

■ PRODUCT VERSION

PRODUCT NAME	FAULT PIN OUTPUT TYPE
NJM2816GM1-51A	No Latch (Automatic Recovery)

■ VOLTAGE CORRECTION CHARACTERISTICS

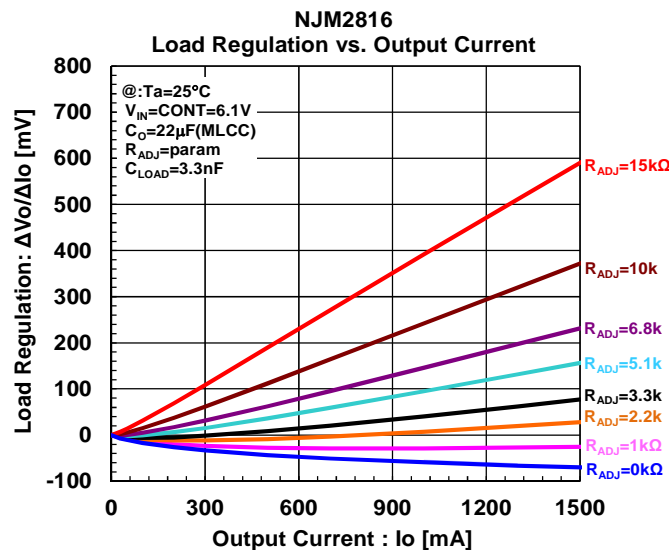

■ BLOCK DIAGRAM

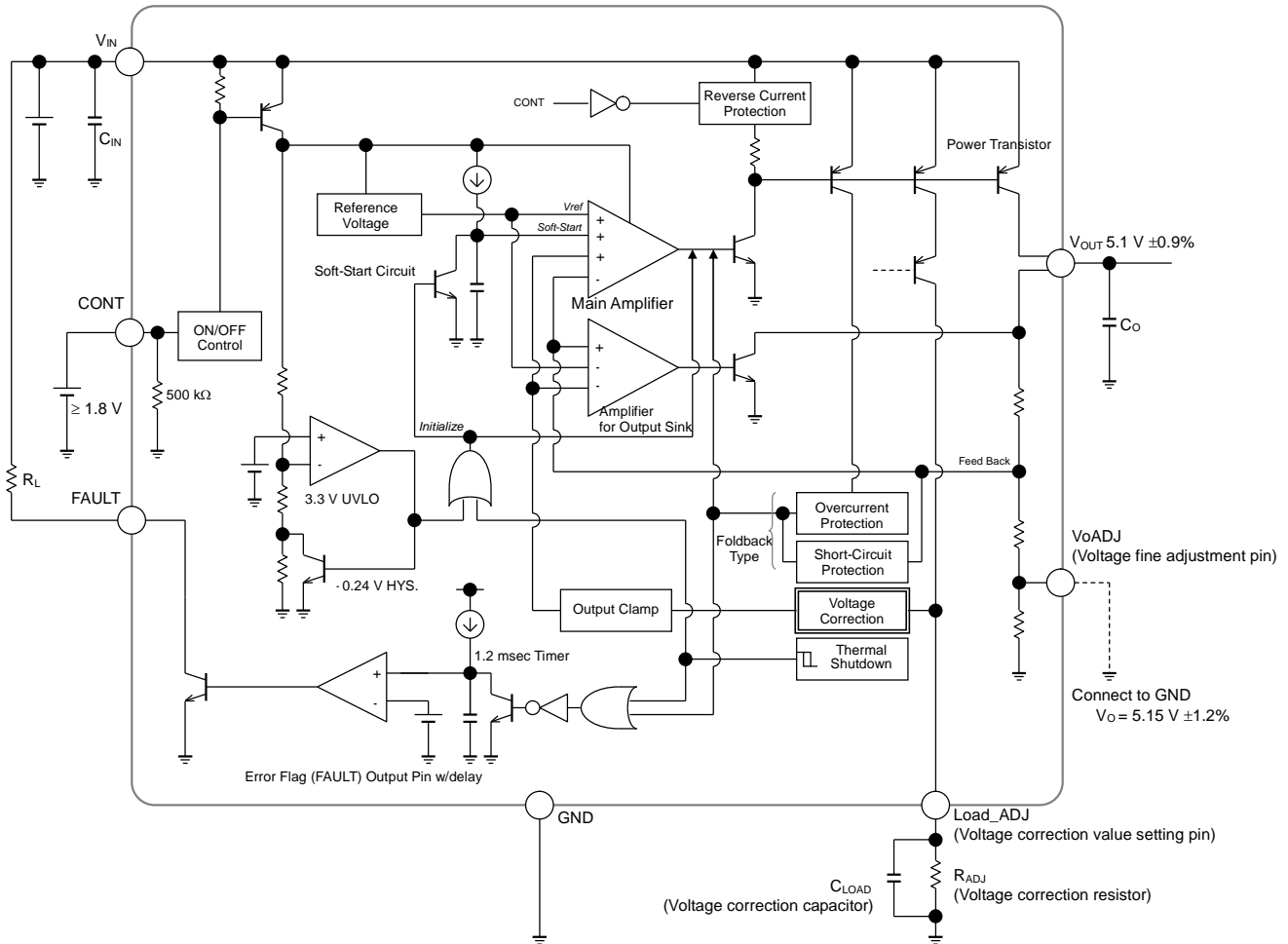

The available output current is limited by HSOP8 package power dissipation. Input the supply voltage considering power dissipation at operating temperature. To supply $I_o = 1.5 \text{ A}$ at $T_a = 85^\circ\text{C}$, $V_{IN} = 6 \text{ V}$ is recommended.

Reverse Current Prevention

The NJW2816 has an internal reverse current prevention circuit that prevents the excessive current to flow the IC when the input pin voltage becomes lower than the output pin voltage. Therefore, no external Schottky barrier diode measure is required.

■ PIN CONFIGURATION

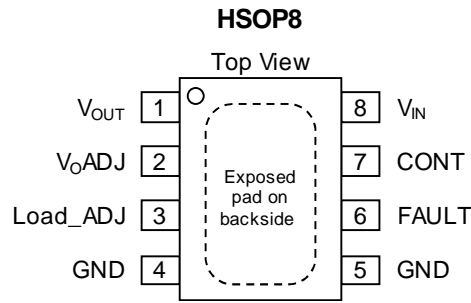

PIN NO.	SYMBOL	DESCRIPTION
1	V_{OUT}	Output pin
2	$V_{O}ADJ$	Output adjustment pin
3	Load_ADJ	Voltage correction adjustment pin
4	GND	Ground pin
5	GND	Ground pin
6	FAULT	Error flag output pin
7	CONT	ON/OFF control pin
8	V_{IN}	Input pin

■ PRODUCT NAME INFORMATION

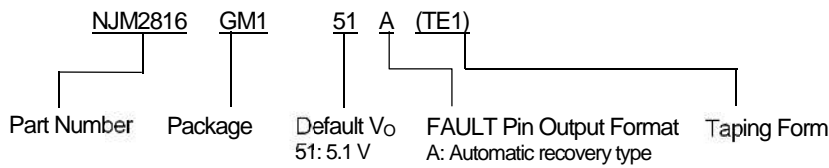

■ ORDER INFORMATION

PRODUCT NAME	PACKAGE	RoHS	HALOGEN-FREE	TERMINAL FINISH	MARKING	WEIGHT (mg)	MOQ (pcs)
NJM2816GM1-51A (TE1)	HSOP8	Yes	Yes	Sn 100%	2816NA	81	3000

■ ABSOLUTE MAXIMUM RATINGS

PARAMETER	SYMBOL	RATING	UNIT
Input Voltage	V_{IN}	+10	V
Control Voltage	V_{CONT}	+10	V
FAULT Pin Voltage	V_{FAULT}	+10	V
Power Dissipation ($T_a = 25^\circ\text{C}$) HSOP8	P_D	2-Layer ⁽¹⁾ / 4-Layer ⁽²⁾ 790 / 2500	mW
Junction Temperature	T_j	-40 to 150	$^\circ\text{C}$
Operating Temperature	T_{opr}	-40 to 125	$^\circ\text{C}$
Storage Temperature	T_{stg}	-50 to 150	$^\circ\text{C}$

(1) 2-Layer: Mounted on glass epoxy board (76.2 mm × 114.3 mm × 1.6 mm: based on EIA/JEDEC standard, 2-layer FR-4).

(2) 4-Layer: Mounted on glass epoxy board (76.2 mm × 114.3 mm × 1.6 mm: based on EIA/JEDEC standard, 4-layer FR-4).

(For 4-layer: Applying 74.2 mm × 74.2 mm inner Cu area and a thermal via hole to a board based on JEDEC standard JESD51-5.)

■ RECOMMENDED OPERATING CONDITIONS

PARAMETER	SYMBOL	VALUE	UNIT
Input Voltage	V_{IN}	5.5 to 8	V
Output Current	I_o	0 to 1.5	A

■ ELECTRICAL CHARACTERISTICS

$V_{IN} = V_O + 1\text{ V}$, $C_{IN} = 10\ \mu\text{F}$, $C_O = 22\ \mu\text{F}$, $T_a = 25^\circ\text{C}$, unless otherwise noted.

PARAMETER	SYMBOL	TEST CONDITIONS	MIN	TYP	MAX	UNIT
REGULATOR						
Input Voltage	V_{IN}		5.5	-	8	V
Output Voltage	V_O	$I_O = 0\text{ mA}$	5.055	5.100	5.145	V
Output Voltage 2	V_{O2}	$I_O = 0\text{ mA}$, $V_{O\text{ADJ}} = 0\text{ V}$	5.09	5.15	5.21	V
Average Temperature Coefficient of Output Voltage	$\Delta V_O / \Delta T_a$	$T_a = 0^\circ\text{C}$ to 85°C	-	± 50	-	ppm/ $^\circ\text{C}$
Load Regulation 1	$\Delta V_O / \Delta I_{O1}$	$R_{\text{ADJ}} = 10\text{ k}\Omega$, 0 to 1.5 A	+325	+375	+425	mV
Load Regulation 2	$\Delta V_O / \Delta I_{O2}$	$R_{\text{ADJ}} = 6.8\text{ k}\Omega$, 0 to 1.5 A	+180	+230	+280	mV
Load Regulation 3	$\Delta V_O / \Delta I_{O3}$	$R_{\text{ADJ}} = 5.1\text{ k}\Omega$, 0 to 1.5 A	+105	+155	+205	mV
Line Regulation	$\Delta V_O / \Delta V_{IN}$	$V_{IN} = 6\text{ V}$ to 8 V	-	-	10	mV
Dropout Voltage	ΔV_{I-O}	$I_O = 1.5\text{ A}$	-	0.25	0.35	V
Quiescent Current	I_Q	$I_O = 0\text{ mA}$, except I_{CONT}	-	1150	1600	μA
Quiescent Current at Control OFF	$I_{Q(\text{OFF})}$	$V_{\text{CONT}} = 0\text{ V}$	-	-	1	μA
Output Current	I_O	$V_O \times 0.9$	1.8	2.2	-	A
Soft-Start Time	SS	from $\text{CONT} = \text{high}$ to $V_O \times 0.9$	-	4	8	msec
Control Current	I_{CONT}	$V_{\text{CONT}} = 1.8\text{ V}$	-	3	12	μA
Output ON Control Voltage	$V_{\text{CONT(ON)}}$		1.8	-	-	V
Output OFF Control Voltage	$V_{\text{CONT(OFF)}}$		-	-	0.5	V
Output Clamp Voltage	V_{O_CLAMP}		6.0	-	6.4	V
Reverse Bias Current	I_{O_REV}	$V_{\text{CONT}} = 0\text{ V}$, $V_O = 5.0\text{ V}$, $V_{IN} = 0\text{ V}$	-	-	0.5	mA
Power Supply Short-Circuit Voltage	V_{ODCIN}	Connect series resistance: $1\text{ k}\Omega$	16	-	-	V
UNDERVOLTAGE LOCKOUT (UVLO)						
V_{IN} Undervoltage Lockout Threshold Voltage	V_{INUVLO}	V_{IN} : SWEEP UP	3.1	3.3	3.5	V
V_{IN} Undervoltage Lockout Hysteresis Voltage	V_{INHYS}	V_{IN} : SWEEP DOWN	180	240	300	mV
FAULT OUTPUT						
L Level Output Voltage	V_{ORL}	$R_L = 100\text{ k}\Omega$	1	25	150	mV
FAULT Output Current at ON-State	I_{ORL}	$R_L = 0\text{ k}\Omega$	5	100	220	mA
FAULT Output Delay Time	T_d		-	1.2	2.8	msec
FAULT Detection Current	I_{O_det}		1.7	2.1	-	A

■ THERMAL CHARACTERISTICS

PACKAGE	SYMBOL	VALUE	UNIT
Junction-to-Ambient Thermal Resistance HSOP8	θ_{ja}	2-Layer ⁽¹⁾ / 4-Layer ⁽²⁾ 158 / 50	°C/W
Junction-to-Top of Package Characterization Parameter HSOP8	Ψ_{jt}	2-Layer ⁽¹⁾ / 4-Layer ⁽²⁾ 28 / 12	°C/W

■ POWER DISSIPATION vs. AMBIENT TEMPERATURE

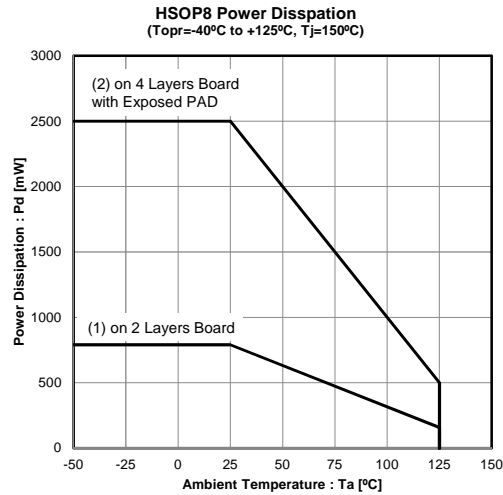

- (1) 2-Layer: Mounted on glass epoxy board (76.2 mm × 114.3 mm × 1.6 mm: based on EIA/JEDEC standard, 2-layer FR-4).
- (2) 4-Layer: Mounted on glass epoxy board (76.2 mm × 114.3 mm × 1.6 mm: based on EIA/JEDEC standard, 4-layer FR-4).
(For 4-layer: Applying 74.2 mm × 74.2 mm inner Cu area and a thermal via hole to a board based on JEDEC standard JESD51-5.)

■ TYPICAL CHARACTERISTICS

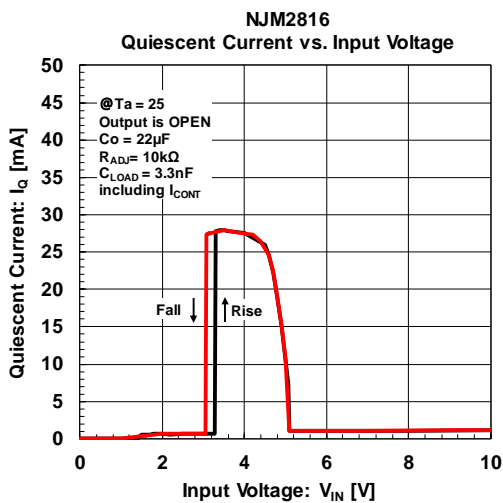
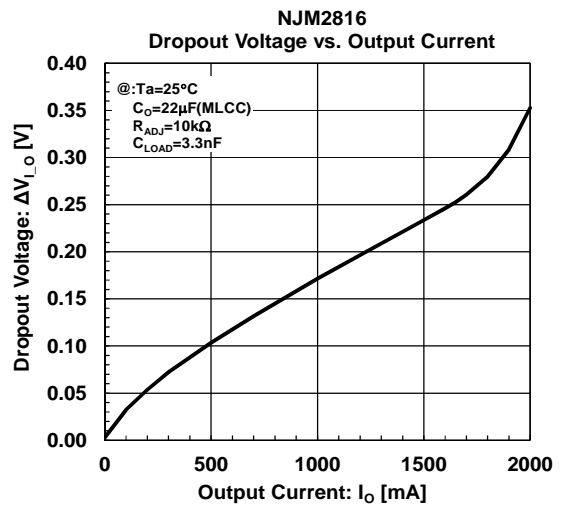
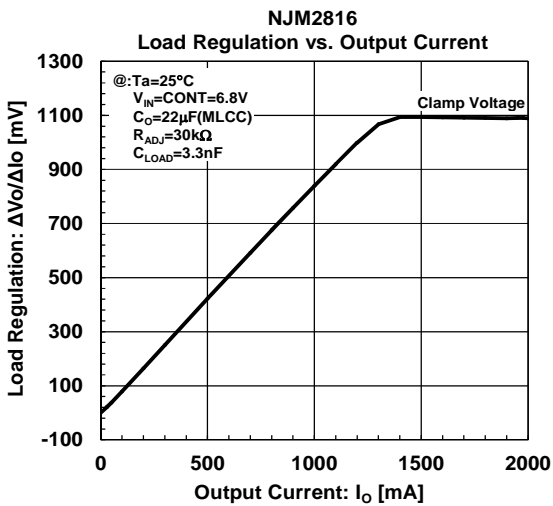
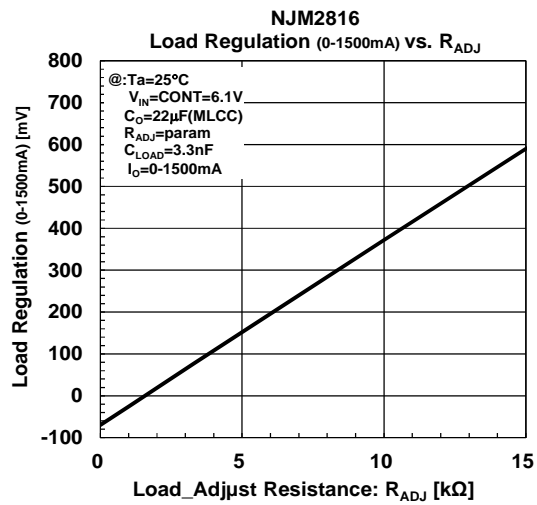
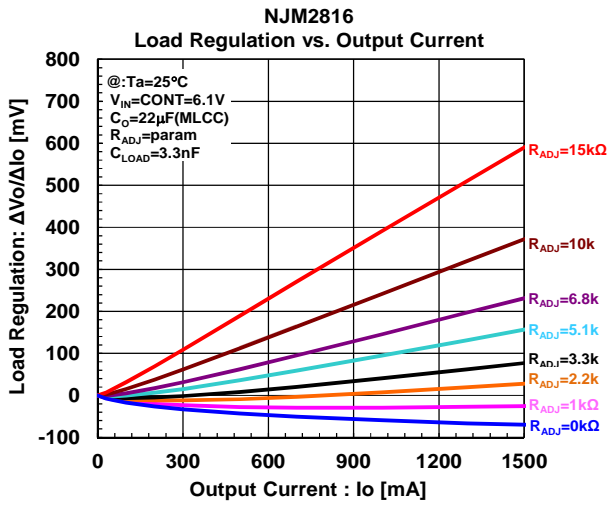

■ TYPICAL CHARACTERISTICS

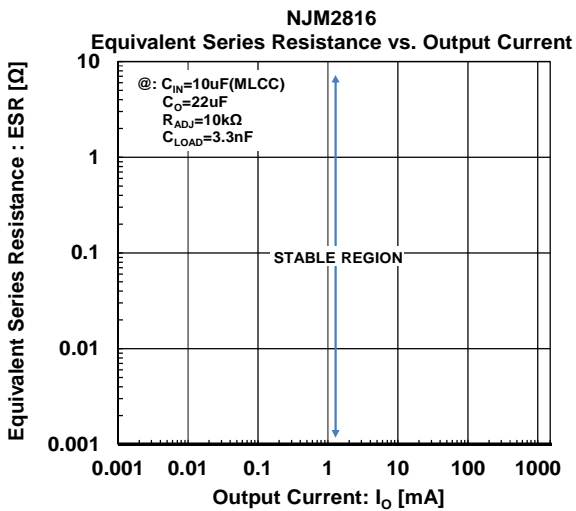
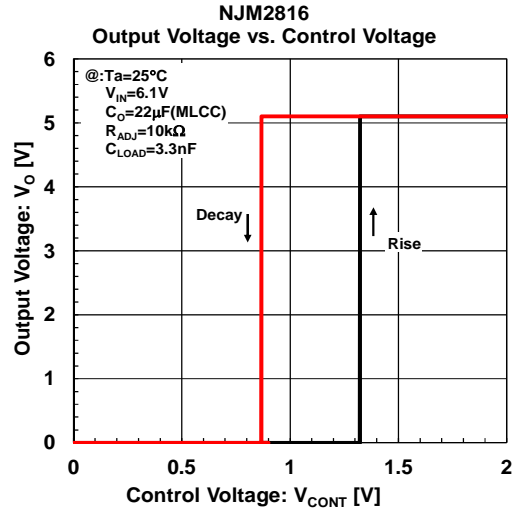
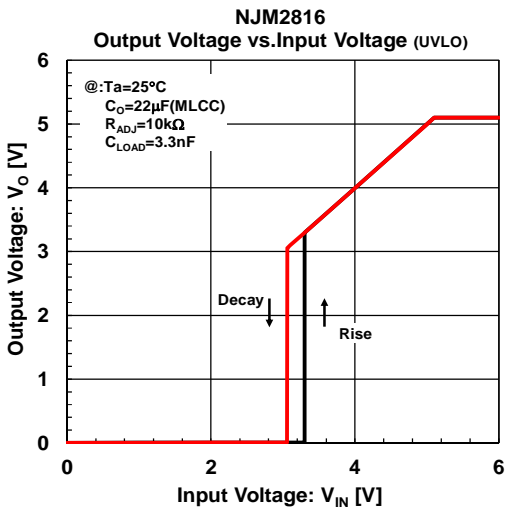
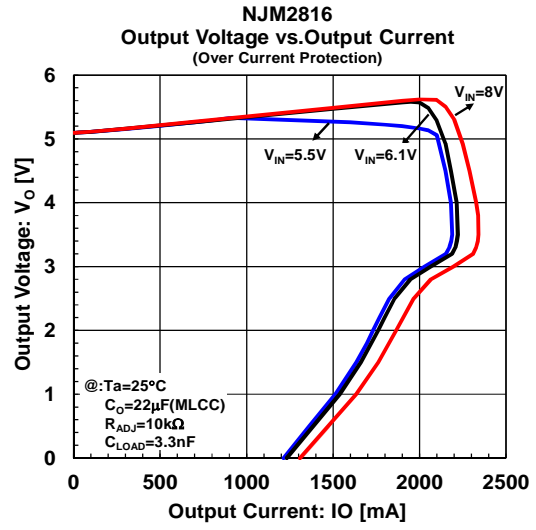
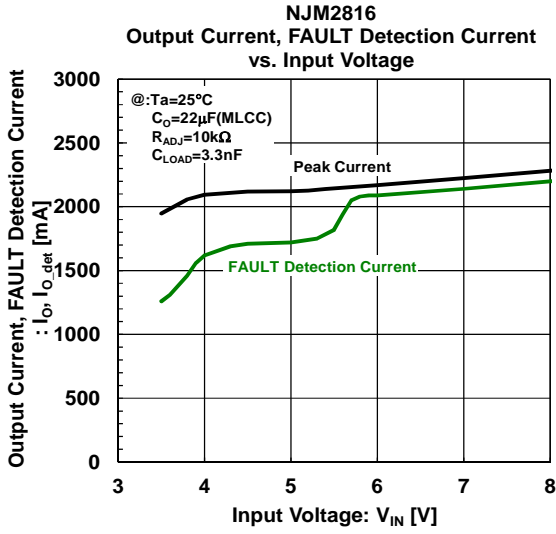

MEASUREMENT CIRCUIT

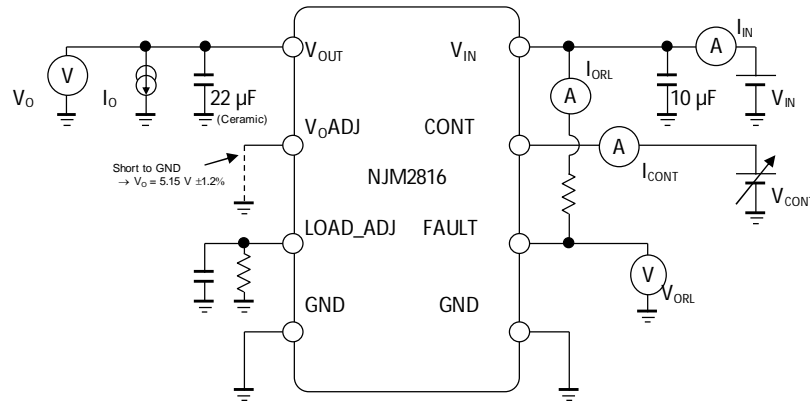

TYPICAL APPLICATION

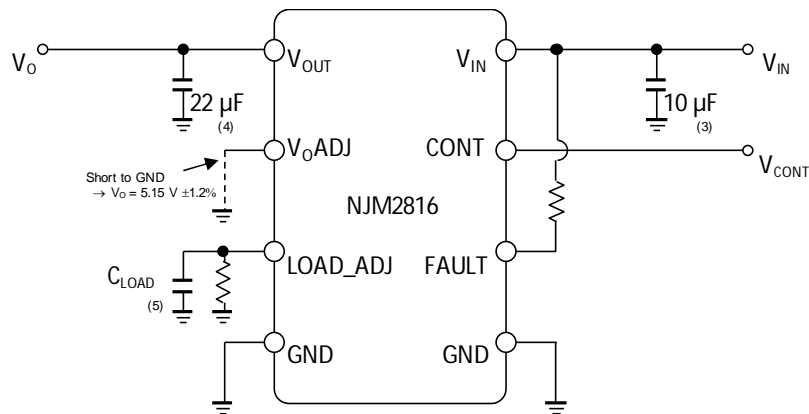

Input Capacitor (C_{IN})

The C_{IN} prevents oscillations when the power supply impedance is high or the V_{IN} or GND power supply line is long. Connecting a 10 μF or larger C_{IN} with low ESR (Equivalent Series Resistance) between V_{IN} and GND pins as short path as possible.

Output Capacitor (C_O)

C_O is necessary for phase compensation of the internal error amplifier in the regulator, and the capacitance value and ESR affect the stability of the circuit. If a capacitor less than the recommended capacitance value is used, output noise and/or regulator oscillation may occur due to lack of the phase compensation. For stable operation, connect a 22 μF or larger C_O between the V_{OUT} and GND pins as short path as possible. In many LDO regulators, the C_O acts as an auxiliary power supply for charging the load; therefore, using a large C_O can suppress voltage fluctuations due to load fluctuations. Unlike typical products, the NJM2816 has internal voltage correction that controls the output voltage to increase in proportion to the output current. In the process of raising the voltage, the C_O that is larger than necessary can cause a decrease in correction speed and/or oscillations.

Select the output capacitor considering various characteristics such as frequency characteristics, temperature characteristics, and DC bias characteristics. For the C_O , a capacitor with excellent temperature characteristics and sufficient margin for output voltage is recommended.

Load_ADJ Capacitor (C_{LOAD})

The output voltage increases in proportional to the output current (positive feedback control). C_{LOAD} is required to reduce the speed of positive feedback control and suppress oscillations. The smaller C_{LOAD} , the faster the voltage correction speed when the load fluctuations; however, as the C_O and/or the amount of the correction increase, the speed of the positive feedback loop needs to be reduced. Perform sufficient evaluation using the actual application to select the C_{LOAD} .

■ PIN FUNCTIONS

PIN NO.	SYMBOL	DESCRIPTION
1	V _{OUT}	Regulator output pin. The correction voltage is added to the output voltage (5.1 V ±0.9%). The IC has an internal overcurrent protection and a short-circuit protection. The output current is limited at 1.8 A. When shorted to GND, the output current is limited at 1.3 A (typ) (design value). Connect a C _O ≥ 22 μF, between this pin and the GND pin to prevent output oscillations.
2	V _O ADJ	Output voltage adjustment pin. The output voltage becomes 5.1 V ±0.9% at open, and when connected to GND potential, it becomes 5.15 V ±1.2%. Leave this pin open when not in use.
3	Load_ADJ	Voltage correction (load regulation) adjustment pin. The load regulation (0 mA to 1500 mA) at R _{ADJ} = 10 kΩ is +375 mV (typ). Connect the C _{LOAD} in parallel to R _{ADJ} to prevent oscillations caused by voltage correction. The clamp voltage (6.4 V, max) is not depending on R _{ADJ} .
4, 5	GND	Ground pin
6	FAULT	Error flag output pin. If an error is detected, a low signal is output. Connect to a power line via pull-up resistor because it is an open collector pin of the NPN transistor. The error flag is output during overcurrent protection, short-circuit protection, or thermal shutdown. This device has output delay time of 1.2 msec (typ).
7	CONT	ON/OFF control pin. It is high active. This pin is pulled down with 500 kΩ (typ) and fixed to OFF state when the CONT pin is open. 0.5 V ≤ CONT voltage ≤ 1.8 V is an indefinite region.
8	V _{IN}	Power supply pin. Input Capacitor (C _{IN}) is required to prevent oscillations due to rise of the power supply impedance. Connect a capacitor with a sufficiently low ESR and C _{IN} ≥ 10 μF between this pin and the GND pin as short path as possible.
-	Exposed pad	Connected to the 4 pin and the 5 pin of GND pin.

■ APPLICATION NOTE**Main Amplifier**

This amplifier is an error amplifier that controls the power transistor by comparing the internal reference voltage and the output voltage (V_O). This amplifier has a function to adjust the offset voltage according to the Load_ADJ pin voltage. By this function, a drop voltage due to the influence of cable impedance is corrected. The phase compensation allows to use wide range of output capacitors from $0.02 \Omega \leq ESR \leq 30 \Omega$ with $C_O = 22 \mu\text{F}$, $C_{LOAD} = 3.3 \text{ nF}$. See the *OUTPUT STABILITY* on page 15.

Output Sink Amplifier

This circuit discharges the electrical charge of output capacitor to prevent output voltage overshoot when load is open.

Soft-Start

The V_O pin voltage is slowly increased when the CONT pin goes from low to high or V_{IN} rises above the UVLO threshold voltage (3.3 V, typ), and the rush current to the output capacitor is reduced. Soft-start is also enabled when the thermal shutdown is released. The soft-start time is defined as the time from CONT = high to rising to $V_O \times 0.9$, which is 4 msec (typ).

ON/OFF Control

This circuit controls regulator ON/OFF. The quiescent current at OFF is 1 μA (max). This pin can be controlled by CMOS logic voltage, thus the CONT pin is high impedance. The CONT pin is pulled down with internal resistor of 500 k Ω (typ). At the OFF state, the error flag (FAULT pin = low) is not output.

 V_{IN} Undervoltage Lockout (UVLO)

This circuit prevents malfunction by locking out the output when V_{IN} is below the UVLO detection voltage. The output voltage rises when the input voltage rises and exceeds the V_{IN} undervoltage lockout threshold voltage (3.3 V, typ). When the input voltage drops below the UVLO detection voltage (3.06 V, typ)*, the output voltage falls. The error flag (FAULT pin = low) is not output during lockout.

*UVLO detection voltage (3.06 V, typ) = V_{IN} undervoltage lockout threshold voltage (3.3 V, typ) – V_{IN} undervoltage lockout hysteresis voltage (0.24 V, typ)

Overcurrent Protection / Short-Circuit Protection

The NJM2816 has an overcurrent protection and a short-circuit protection. The overcurrent protection characteristic is foldback current limit. This circuit outputs an error flag (FAULT pin = low) in either case of the over current protection or the short-circuit protection operates.

Thermal Shutdown

When the NJM2816 chip (junction) temperature exceeds 170°C, the output is turned off and when the chip temperature decrease less than 145°C the output is turned on. If the overload condition continues constantly, the output repeats ON/OFF, so the output voltage may appear to oscillate greatly. This function is built-in to protect the IC; therefore, do thermal design below T_{jmax} . When the thermal shutdown operates, the error flag (FAULT pin = low) is output.

Voltage Correction

This circuit generates a correction voltage proportional to the output current.

Error Flag (FAULT) Output Circuit with Delay Function

This circuit operates during overcurrent protection, short-circuit protection, or thermal shutdown. Flowing a current to the external pull-up resistor R_L connected to the FAULT pin and outputs an error flag (FAULT pin = low). An error flag is output 1.2 msec (typ) after entering the protection state and the rush current when a USB device is connected can be ignored. The current capability of the FAULT pin is 5 mA (min).

Reverse Current Prevention

The NJW2816 has an internal reverse current prevention circuit that prevents the excessive current to flow the IC when the input pin voltage becomes lower than the output pin voltage. Therefore, no external Schottky barrier diode measure is required. The error flag is not output if reverse current flows.

 V_{OADJ} (Output Voltage Adjustment) Pin

With connecting this pin to GND, the output voltage can be adjusted from 5.1 V $\pm 0.9\%$ to 5.15 V $\pm 1.2\%$.

Load_ADJ Pin

A current proportional to the amount of power transistor current is output to this pin. The slope of load regulation can be adjusted by changing the resistor value (R_{ADJ}) connected to this pin. The load regulation (0 mA to 1500 mA) at $R_{ADJ} = 10\text{ k}\Omega$ is +375 mV (typ). See the *Voltage Correction (Load Regulation) Adjustment* for more information on selecting R_{ADJ} . Connect the C_{LOAD} in parallel to R_{ADJ} to prevent oscillations caused by voltage correction.

Output Clamp

This circuit prevents a load breakdown due to excessive rising of output voltage when the correction is too strong or the R_{ADJ} resistance is removed. The output voltage is clamped at 6.0 V to 6.4 V.

Timing Chart

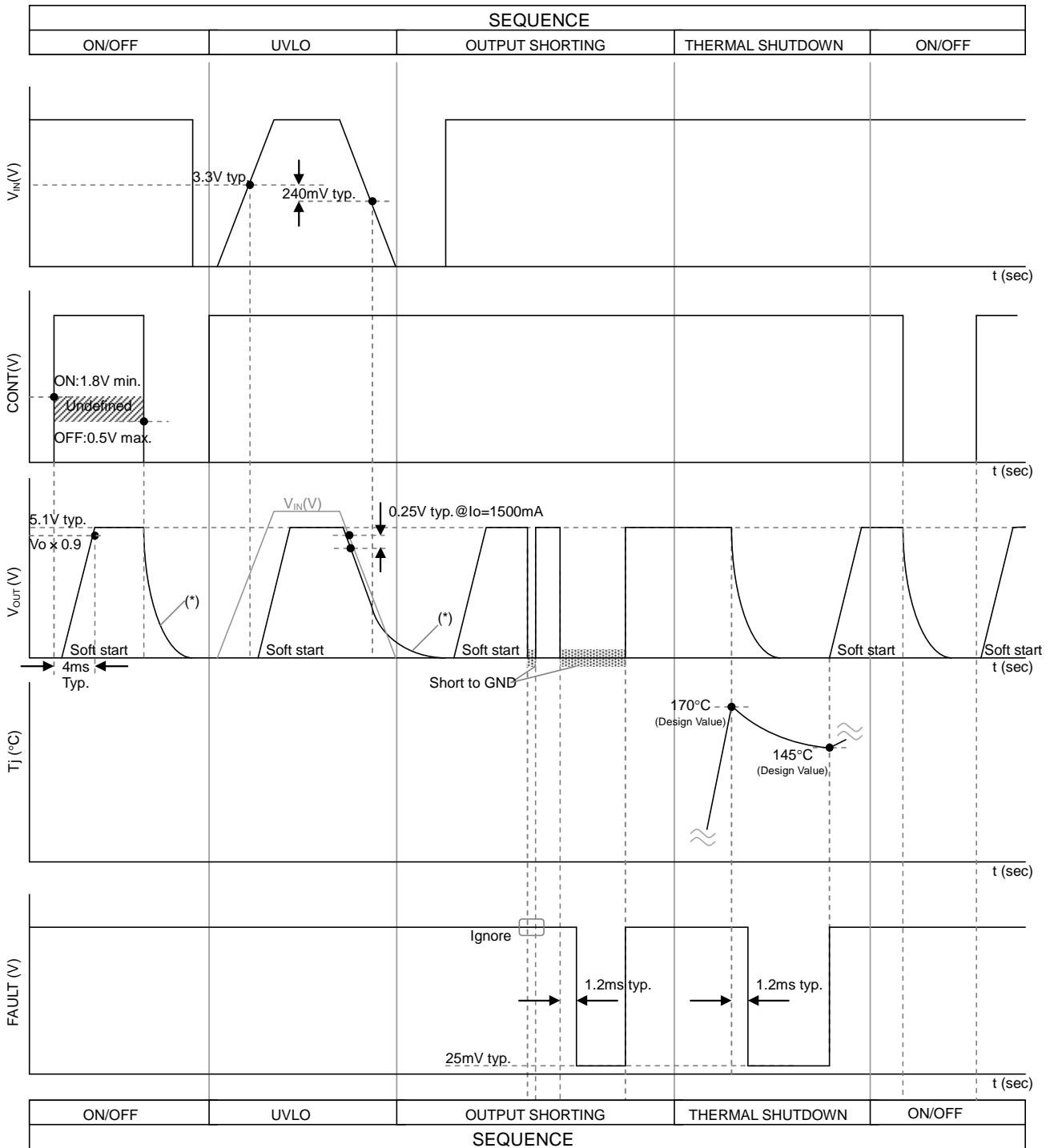

*The NJM2816 does not have an output capacitor discharge function in the OFF state and UVLO detection.

Voltage Correction (Load Regulation) Adjustment

The NJM2816 can adjust the load regulation by R_{ADJ} connected to Load_ADJ pin. The R_{ADJ} can be calculated using the following formula.

Load Regulation (0 mA to 100 mA) Formula 25°C (typ)

$$\Delta V_O / \Delta I_{O(0-100mA)} (mV) = 29.4 \times RADJ (k\Omega) \times 0.1 - 15$$

Load Regulation (0 mA to 200 mA) Formula 25°C (typ)

$$\Delta V_O / \Delta I_{O(0-200mA)} (mV) = 29.4 \times RADJ (k\Omega) \times 0.2 - 22$$

Load Regulation (0 mA to 300 mA) Formula 25°C (typ)

$$\Delta V_O / \Delta I_{O(0-300mA)} (mV) = 29.4 \times RADJ (k\Omega) \times 0.3 - 28$$

Load Regulation (0 mA to 500 mA) Formula 25°C (typ)

$$\Delta V_O / \Delta I_{O(0-500mA)} (mV) = 29.4 \times RADJ (k\Omega) \times 0.5 - 35$$

Load Regulation (0 mA to 1000 mA) Formula 25°C (typ)

$$\Delta V_O / \Delta I_{O(0-1000mA)} (mV) = 29.4 \times RADJ (k\Omega) \times 1 - 51$$

Load Regulation (0 mA to 1500 mA) Formula 25°C (typ)

$$\Delta V_O / \Delta I_{O(0-1500mA)} (mV) = 29.4 \times RADJ (k\Omega) \times 1.5 - 67$$

Input Voltage and Package Power

Consider the correction voltage and the dropout voltage for the power supply voltage input to the NJM2816.

[e.g.] When voltage correction resistor $R_{ADJ} = 10\text{ k}\Omega$

Determine the minimum input voltage value

Maximum initial output voltage: $V_{O(MAX)} = 5.145\text{ V}$

Maximum load regulation 1: $\Delta V_O / \Delta I_{O1(MAX)} = 425\text{ mV}$

Maximum dropout voltage: $\Delta V_{i-O(MAX)} = 350\text{ mV}$ (Design guarantee value including thermal characteristics = 440 mV)

$$\begin{aligned} V_{IN} &\geq V_{O(MAX)} + \Delta V_O / \Delta I_{O1(MAX)} + \Delta V_{i-O(MAX)} \\ &\geq 5.145\text{ V} + 0.425\text{ V} + 0.44\text{ V} \\ &\geq 5.91\text{ V} \end{aligned}$$

Determine the maximum input voltage value

The maximum output voltage is limited by HSOP8 package power dissipation according to the output current value. Input the supply voltage considering power dissipation at operating temperature. To supply $I_O = 1.5\text{ A}$ at $T_a = 85^\circ\text{C}$, set the dropout voltage below 0.85 V.

Minimum initial output voltage: $V_{O(MIN)} = 5.055\text{ V}$

Minimum load regulation 1: $\Delta V_O / \Delta I_{O1(MIN)} = 325\text{ mV}$

Maximum dropout voltage to supply $I_O = 1.5\text{ A}$ at $T_a = 85^\circ\text{C}$: $\Delta V_{i-O} = 0.85\text{ V}$

$$\begin{aligned} V_{IN} &\geq V_{O(MIN)} + \Delta V_O / \Delta I_{O1(MIN)} + 0.85\text{ V} \\ &\geq 5.055\text{ V} + 0.325\text{ V} + 0.85\text{ V} \\ &\geq 6.23\text{ V} \end{aligned}$$

From the above, when using at an output current of 1.5 A and $R_{ADJ} = 10\text{ k}\Omega$, use within the range of $5.91\text{ V} \leq V_{IN} \leq 6.23\text{ V}$.

Output Stability

The NJM2816 has two feedback loops as shown in Figure 1.

- (1) Negative feedback generates a constant voltage that compares the reference voltage and the output voltage of the error amplifier.
- (2) Positive feedback generates a corrected output voltage proportional to the output current.

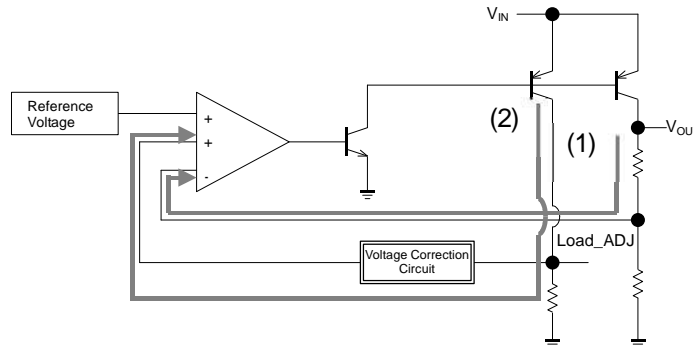

Figure 1. NJM2816 Feedback Loop

When the gain operation of loop (2) is faster and higher than loop (1), the NJM2816 oscillates because the positive feedback control becomes predominant.

The NJM2816 has been confirmed to be stable under the following conditions:

- Output current: 0 mA to 1500 mA
- Output capacitor value: $C_O = 22 \mu\text{F}$
- ESR of output capacitor: $\text{ESR} = 0.02 \Omega$ to 30Ω
- R_{ADJ} : 0 k Ω to 10 k Ω
- C_{LOAD} : 3.3 nF

Use a large C_{LOAD} to reduce the positive feedback loop speed to prevent oscillations under the following conditions.

- When output capacitor (C_O) is larger than $22 \mu\text{F}$ (Negative feedback loop speed of (1) becomes slow).
- When R_{ADJ} is larger than 10 k Ω (Positive feedback loop gain of (2) becomes high).

The ESR and frequency characteristics depend on C_O type and capacitance. Please evaluate the actual application before use.

Output Pin 16V Battery-Short

As shown in Figure 2, under the most severe battery-short test condition ($V_O = 16\text{ V}$, $V_{IN} = 0\text{ V}$), a large current may cause the IC to overheat and be damaged. Figure 2 shows the current path. The main path of reverse current is a power transistor.

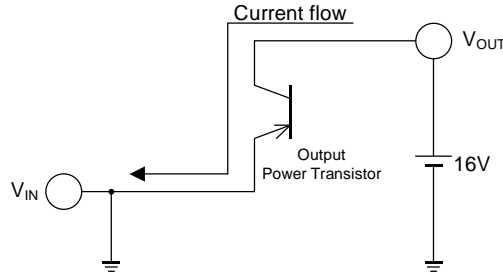

Figure 2. Most Severe Power Line Short Condition

In a standard application (Figure 3) where the NJM2816 is used as a secondary power supply and a DC/DC converter is installed as a primary power supply, current hardly flows and there is no risk of damage of the IC. Typical power supply ICs are designed with large source capability and small sink capability, and the feedback resistor (a few kΩ to hundreds of kΩ) is the main sink path.

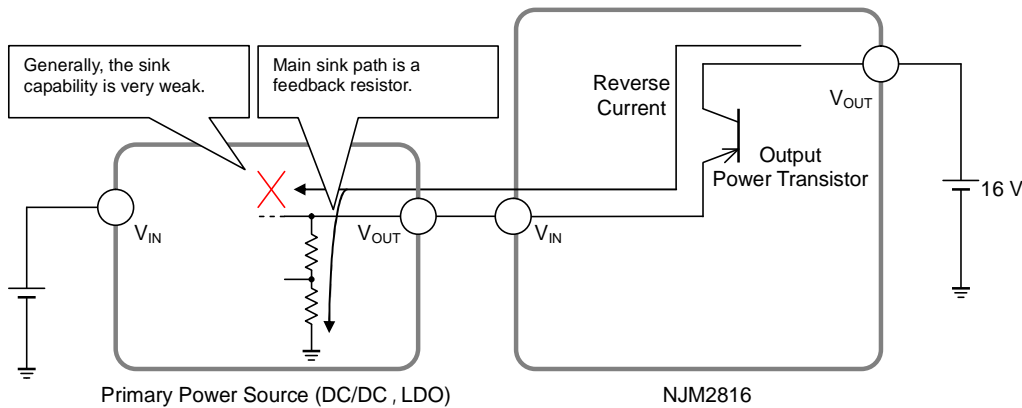
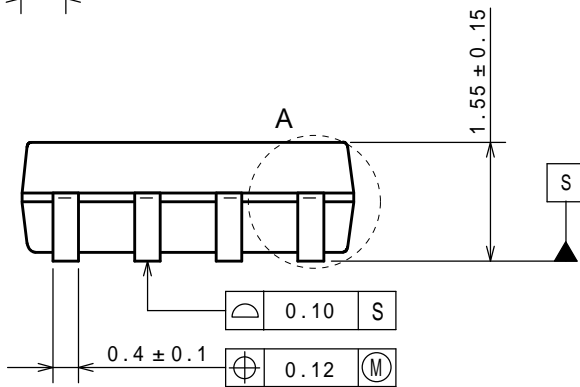
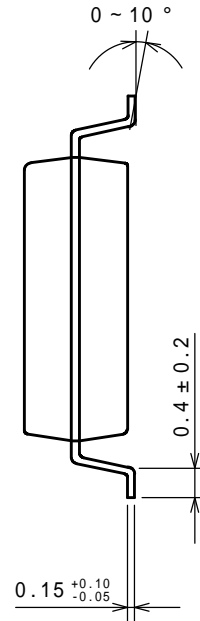
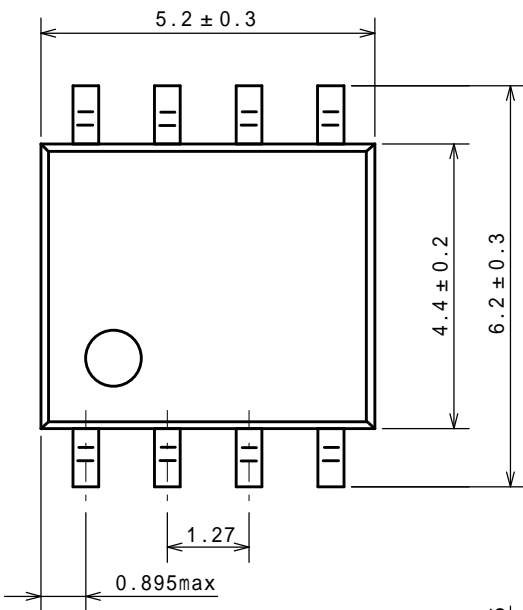

Figure 3. The Power Line Shorting Current Path of Typical Application

If the NJM2816 V_{IN} pin is shorted to GND as shown in Figure 2, a large current flows and it may cause damage to the IC. In standard application as shown in Figure 3, only a small current flows through the feedback resistor of the primary power supply IC. When the primary power supply IC has no sink capability and the feedback resistor is above 1 kΩ, the IC is not breakdown even if battery-short; however, this is not a recommendation for active use of battery-short protection.

PACKAGE DIMENSIONS



Detail drawing of part A

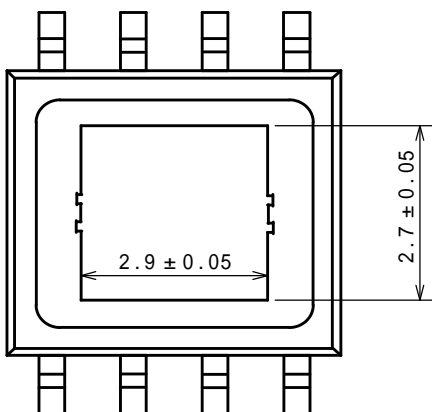
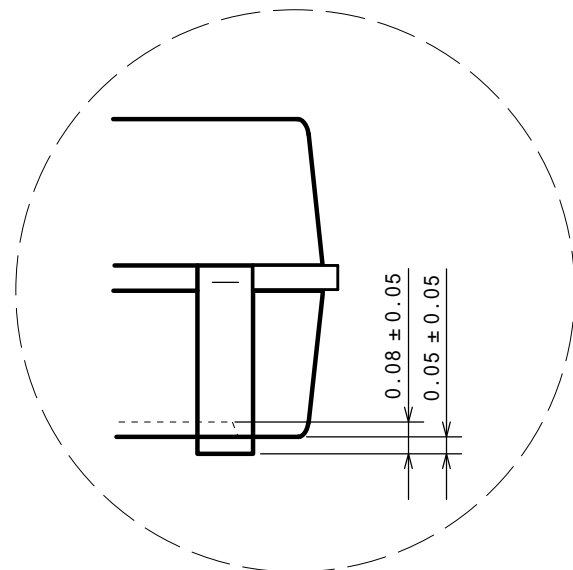

EXAMPLE OF SOLDER PADS DIMENSIONS

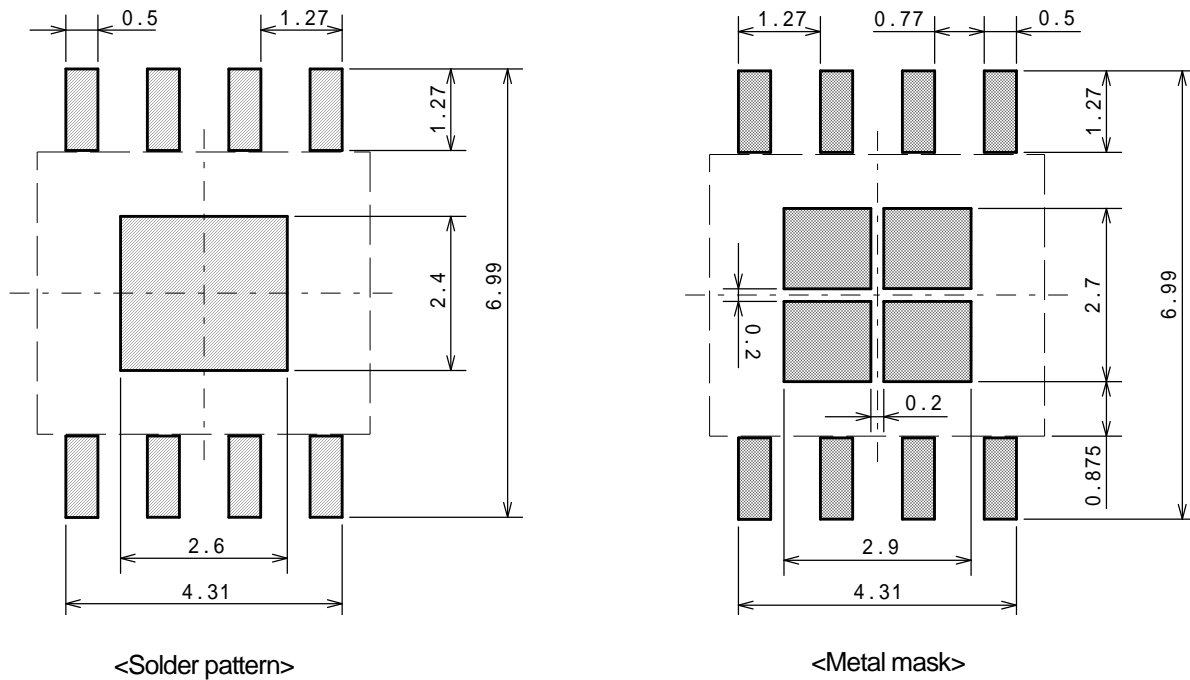

<Instructions for mounting>

Please note the following points when you mount HSOP-8 package IC because there is a standoff on the backside electrode.

(1) Temperature profile of lead and backside electrode.

It is necessary that both re-flow temperature profile of lead and backside electrodes are higher than preset temperature. When solder wet temperature is lower than lead/backside electrode temperature, there is possibility of defect mounting.

(2) Design of foot pattern / metal mask

Metal mask thickness of solder pattern print is more than 0.13 mm.

(3) Solder paste

The mounting was evaluated with following solder paste, foot pattern and metal mask.

Because mounting might be greatly different according to the manufacturer and the product number even if the solder composition is the same.

We will strongly recommend to evaluate mounting previously with using foot pattern, metal mask and solder paste.

Solder paste composition	Sn37Pb (Senju Metal Industry Co., Ltd: OZ7053-340F-C)
	Sn3Ag0.5Cu (Senju Metal Industry Co., Ltd: M705-GRN350-32-11)

PACKING SPEC

TAPING DIMENSIONS

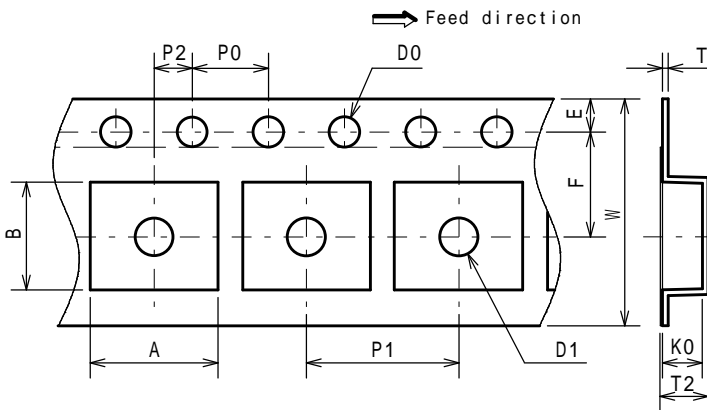

SYMBOL	DIMENSION	REMARKS
A	6.7 ± 0.1	
B	5.55 ± 0.1	
D0	1.55 ± 0.05	
D1	2.05 ± 0.05	
E	1.75 ± 0.1	
F	5.5 ± 0.05	
P0	4.0 ± 0.1	
P1	8.0 ± 0.1	
P2	2.0 ± 0.05	
T	0.3 ± 0.05	
T2	2.47	
K0	2.1 ± 0.1	
W	12.0 ± 0.2	

REEL DIMENSIONS

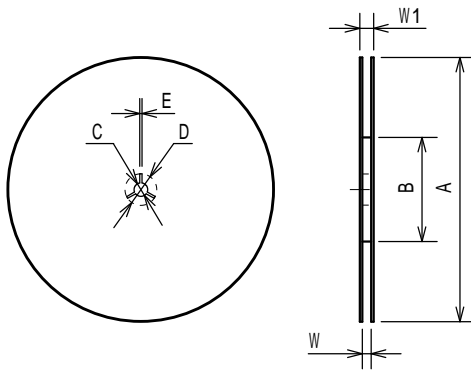

SYMBOL	DIMENSION
A	330 ± 2
B	80 ± 1
C	13 ± 0.2
D	21 ± 0.8
E	2 ± 0.5
W	13.5 ± 0.5
W1	17.5 ± 1

TAPING STATE

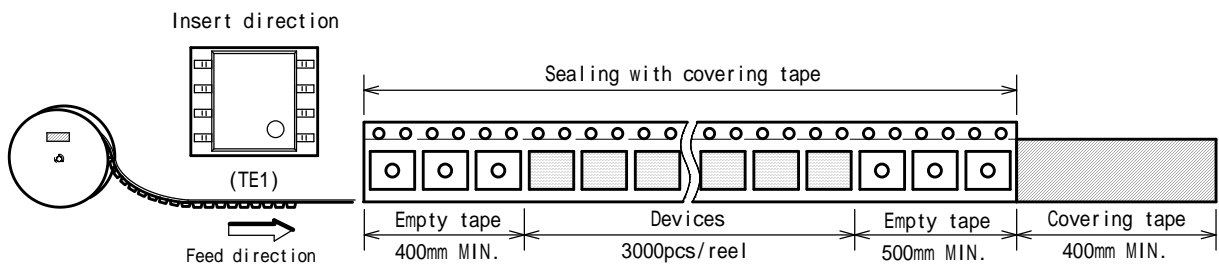

PACKING STATE

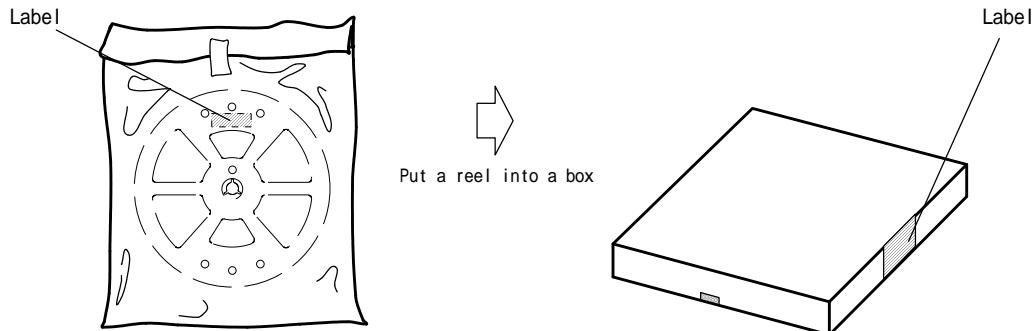

■ RECOMMENDED MOUNTING METHOD

INFRARED REFLOW SOLDERING PROFILE

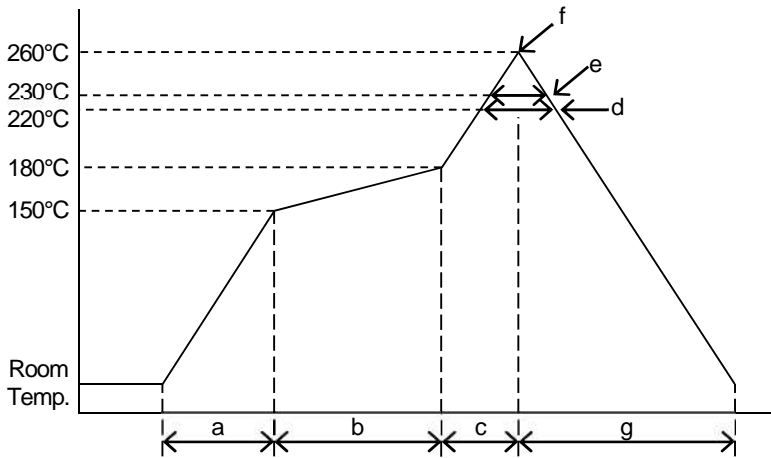

a	Temperature ramping rate	1 to 4°C/s
b	Pre-heating temperature	150 to 180°C
	Pre-heating time	60 to 120s
c	Temperature ramp rate	1 to 4°C/s
d	220°C or higher time	shorter than 60s
e	230°C or higher time	shorter than 40s
f	Peak temperature	lower than 260°C
g	Temperature ramping rate	1 to 6°C/s

The temperature indicates at the surface of mold package.

■ REVISION HISTORY

DATE	REVISION	CHANGES
December 7, 2020	Ver.1.0	Initial release due to datasheet format change

[CAUTION]

1. NJR strives to produce reliable and high quality semiconductors. NJR's semiconductors are intended for specific applications and require proper maintenance and handling. To enhance the performance and service of NJR's semiconductors, the devices, machinery or equipment into which they are integrated should undergo preventative maintenance and inspection at regularly scheduled intervals. Failure to properly maintain equipment and machinery incorporating these products can result in catastrophic system failures
2. The specifications on this datasheet are only given for information without any guarantee as regards either mistakes or omissions. The application circuits in this datasheet are described only to show representative usages of the product and not intended for the guarantee or permission of any right including the industrial property rights.
All other trademarks mentioned herein are the property of their respective companies.
3. To ensure the highest levels of reliability, NJR products must always be properly handled.
The introduction of external contaminants (e.g. dust, oil or cosmetics) can result in failures of semiconductor products.
4. NJR offers a variety of semiconductor products intended for particular applications. It is important that you select the proper component for your intended application. You may contact NJR's Sale's Office if you are uncertain about the products listed in this datasheet.
5. Special care is required in designing devices, machinery or equipment which demand high levels of reliability. This is particularly important when designing critical components or systems whose failure can foreseeably result in situations that could adversely affect health or safety. In designing such critical devices, equipment or machinery, careful consideration should be given to amongst other things, their safety design, fail-safe design, back-up and redundancy systems, and diffusion design.
6. The products listed in this datasheet may not be appropriate for use in certain equipment where reliability is critical or where the products may be subjected to extreme conditions. You should consult our sales office before using the products in any of the following types of equipment.
 - Aerospace Equipment
 - Equipment Used in the Deep Sea
 - Power Generator Control Equipment (Nuclear, steam, hydraulic, etc.)
 - Life Maintenance Medical Equipment
 - Fire Alarms / Intruder Detectors
 - Vehicle Control Equipment (Airplane, railroad, ship, etc.)
 - Various Safety Devices
7. NJR's products have been designed and tested to function within controlled environmental conditions. Do not use products under conditions that deviate from methods or applications specified in this datasheet. Failure to employ the products in the proper applications can lead to deterioration, destruction or failure of the products. NJR shall not be responsible for any bodily injury, fires or accident, property damage or any consequential damages resulting from misuse or misapplication of the products. The products are sold without warranty of any kind, either express or implied, including but not limited to any implied warranty of merchantability or fitness for a particular purpose.
8. Warning for handling Gallium and Arsenic (GaAs) Products (Applying to GaAs MMIC, Photo Reflector). These products use Gallium (Ga) and Arsenic (As) which are specified as poisonous chemicals by law. For the prevention of a hazard, do not burn, destroy, or process chemically to make them as gas or power. When the product is disposed of, please follow the related regulation and do not mix this with general industrial waste or household waste.
9. The product specifications and descriptions listed in this datasheet are subject to change at any time, without notice.

