

## INVERTER GRADE THYRISTORS

### Stud Version

### Features

- All diffused design
- Center amplifying gate
- Guaranteed high dv/dt
- Guaranteed high di/dt
- High surge current capability
- Low thermal impedance
- High speed performance

85A

### Typical Applications

- Inverters
- Choppers
- Induction heating
- All types of force-commutated converters

### Major Ratings and Characteristics

Parameters	ST083S	Units
$I_{T(AV)}$	85	A
@ $T_C$	85	°C
$I_{T(RMS)}$	135	A
$I_{TSM}$ @ 50Hz	2450	A
@ 60Hz	2560	A
$I^2t$ @ 50Hz	30	KA <sup>2</sup> s
@ 60Hz	27	KA <sup>2</sup> s
$V_{DRM}/V_{RRM}$	400 to 1200	V
$t_q$ range (*)	10 to 30	μs
$T_J$	- 40 to 125	°C

(\*)  $t_q = 10$  to  $20\mu s$  for 400 to 800V devices  
 $t_q = 15$  to  $30\mu s$  for 1000 to 1200V devices

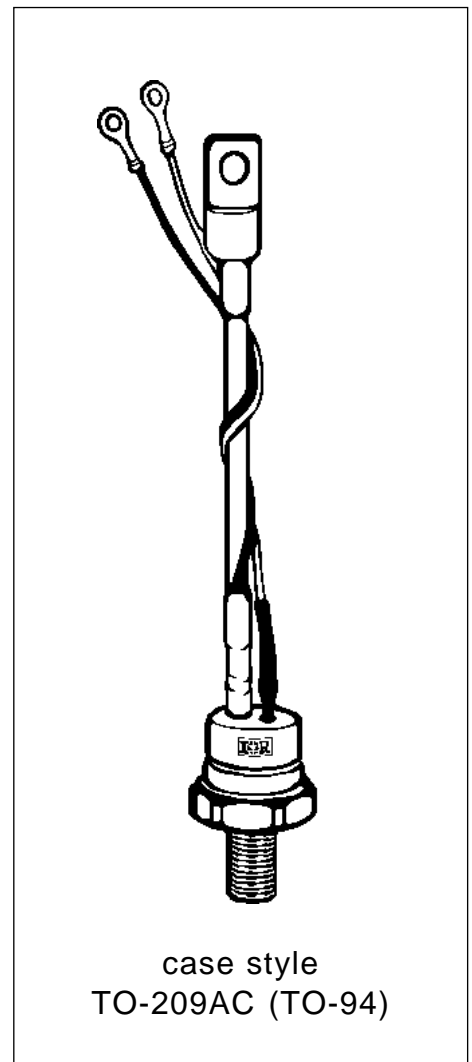

# ST083S Series

## ELECTRICAL SPECIFICATIONS

### Voltage Ratings

Type number	Voltage Code	$V_{DRM}/V_{RRM}$ , maximum repetitive peak voltage V	$V_{RSM}$ , maximum non-repetitive peak voltage V	$I_{DRM}/I_{RRM}$ max. @ $T_J = T_J$ max. mA
ST083S	04	400	500	30
	08	800	900	
	10	1000	1100	
	12	1200	1300	

### Current Carrying Capability

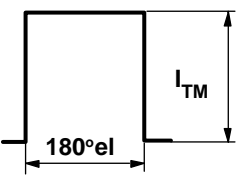
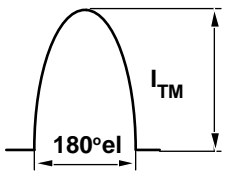
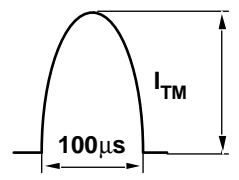
Frequency				Units			
50Hz	210	120	330	270	2540	1930	A
400Hz	200	120	350	210	1190	810	
1000Hz	150	80	320	190	630	400	
2500Hz	70	25	220	85	250	100	
Recovery voltage Vr	50	50	50	50	50	50	V
Voltage before turn-on Vd	$V_{DRM}$		$V_{DRM}$		$V_{DRM}$		
Rise of on-state current di/dt	50	50	-	-	-	-	A/µs
Case temperature	60	85	60	85	60	85	°C
Equivalent values for RC circuit	22Ω / 0.15µF		22Ω / 0.15µF		22Ω / 0.15µF		

### On-state Conduction

Parameter	ST083S	Units	Conditions	
$I_{T(AV)}$ Max. average on-state current @ Case temperature	85	A	180° conduction, half sine wave	
	85	°C		
$I_{T(RMS)}$ Max. RMS on-state current	135	A	DC @ 77°C case temperature	
$I_{TSM}$ Max. peak, one half cycle, non-repetitive surge current	2450		t = 10ms	No voltage
	2560		t = 8.3ms	reapplied
	2060		t = 10ms	100% $V_{RRM}$
	2160	t = 8.3ms	reapplied	
<sup>2</sup> t Maximum $I^2t$ for fusing	30	KA <sup>2</sup> s	t = 10ms	No voltage
	27		t = 8.3ms	reapplied
	21		t = 10ms	100% $V_{RRM}$
	19		t = 8.3ms	reapplied
$I^2\sqrt{t}$ Maximum $I^2\sqrt{t}$ for fusing	300	KA <sup>2</sup> √s	t = 0.1 to 10ms, no voltage reapplied	

## On-state Conduction

Parameter	ST083S	Units	Conditions
$V_{TM}$ Max. peak on-state voltage	2.15	V	$I_{TM} = 300A, T_J = T_J \text{ max}, t_p = 10\text{ms sine wave pulse}$
$V_{T(TO)1}$ Low level value of threshold voltage	1.46		$(16.7\% \times \pi \times I_{T(AV)} < I < \pi \times I_{T(AV)}), T_J = T_J \text{ max.}$
$V_{T(TO)2}$ High level value of threshold voltage	1.52		$(I > \pi \times I_{T(AV)}), T_J = T_J \text{ max.}$
$r_{t1}$ Low level value of forward slope resistance	2.32	m $\Omega$	$(16.7\% \times \pi \times I_{T(AV)} < I < \pi \times I_{T(AV)}), T_J = T_J \text{ max.}$
$r_{t2}$ High level value of forward slope resistance	2.34		$(I > \pi \times I_{T(AV)}), T_J = T_J \text{ max.}$
$I_H$ Maximum holding current	600	mA	$T_J = 25^\circ\text{C}, I_T > 30A$
$I_L$ Typical latching current	1000		$T_J = 25^\circ\text{C}, V_A = 12V, R_a = 6\Omega, I_G = 1A$

## Switching

Parameter	ST083S	Units	Conditions
di/dt Max. non-repetitive rate of rise of turned-on current	1000	A/ $\mu\text{s}$	$T_J = T_J \text{ max}, V_{DRM} = \text{rated } V_{DRM}$ $I_{TM} = 2 \times \text{di/dt}$
$t_d$ Typical delay time	0.80	$\mu\text{s}$	$T_J = 25^\circ\text{C}, V_{DM} = \text{rated } V_{DRM}, I_{TM} = 50A \text{ DC}, t_p = 1\mu\text{s}$ Resistive load, Gate pulse: 10V, 5 $\Omega$ source
$t_q$ Max. turn-off time (*)	Min 10 Max 30		$T_J = T_J \text{ max}, I_{TM} = 100A, \text{commutating di/dt} = 10A/\mu\text{s}$ $V_R = 50V, t_p = 200\mu\text{s}, \text{dv/dt: see table in device code}$

(\*)  $t_q = 10$  to  $20\mu\text{s}$  for 400 to 800V devices;  $t_q = 15$  to  $30\mu\text{s}$  for 1000 to 1200V devices.

## Blocking

Parameter	ST083S	Units	Conditions
dv/dt Maximum critical rate of rise of off-state voltage	500	V/ $\mu\text{s}$	$T_J = T_J \text{ max.}, \text{linear to } 80\% V_{DRM}, \text{higher value available on request}$
$I_{RRM}$ $I_{DRM}$ Max. peak reverse and off-state leakage current	30	mA	$T_J = T_J \text{ max}, \text{rated } V_{DRM}/V_{RRM} \text{ applied}$

## Triggering

Parameter	ST083S	Units	Conditions
$P_{GM}$ Maximum peak gate power	40	W	$T_J = T_J \text{ max}, f = 50\text{Hz}, d\% = 50$
$P_{G(AV)}$ Maximum average gate power	5		
$I_{GM}$ Max. peak positive gate current	5	A	$T_J = T_J \text{ max}, t_p \leq 5\text{ms}$
$+V_{GM}$ Maximum peak positive gate voltage	20	V	$T_J = T_J \text{ max}, t_p \leq 5\text{ms}$
$-V_{GM}$ Maximum peak negative gate voltage	5		
$I_{GT}$ Max. DC gate current required to trigger	200	mA	$T_J = 25^\circ\text{C}, V_A = 12V, R_a = 6\Omega$
$V_{GT}$ Max. DC gate voltage required to trigger	3	V	
$I_{GD}$ Max. DC gate current not to trigger	20	mA	$T_J = T_J \text{ max}, \text{rated } V_{DRM} \text{ applied}$
$V_{GD}$ Max. DC gate voltage not to trigger	0.25	V	

# ST083S Series

## Thermal and Mechanical Specifications

Parameter	ST083S	Units	Conditions
T <sub>J</sub> Max. junction operating temperature range	-40 to 125	°C	
T <sub>stg</sub> Max. storage temperature range	-40 to 150		
R <sub>thJC</sub> Max. thermal resistance, junction to case	0.195	K/W	DC operation
R <sub>thCS</sub> Max. thermal resistance, case to heatsink	0.08		Mounting surface, smooth, flat and greased
T Mounting torque, ± 10%	15.5 (137)	Nm (lbf-in)	Non lubricated threads
	14 (120)	Nm (lbf-in)	Lubricated threads
wt Approximate weight	130	g	
Case style	TO-209AC (TO-94)		See Outline Table

## ΔR<sub>thJC</sub> Conduction

(The following table shows the increment of thermal resistance R<sub>thJC</sub> when devices operate at different conduction angles than DC)

Conduction angle	Sinusoidal conduction	Rectangular conduction	Units	Conditions
180°	0.034	0.025	K/W	T <sub>J</sub> = T <sub>J</sub> max.
120°	0.041	0.042		
90°	0.052	0.056		
60°	0.076	0.079		
30°	0.126	0.127		

## Ordering Information Table

**Device Code**

ST	08	3	S	12	P	F	K	0	
1	2	3	4	5	6	7	8	9	10

- 1** - Thyristor
- 2** - Essential part number
- 3** - 3 = Fast turn off
- 4** - S = Compression bonding Stud
- 5** - Voltage code: Code x 100 = V<sub>RRM</sub> (See Voltage Ratings Table)
- 6** - P = Stud Base 1/2" 20UNF
- 7** - Reapplied dv/dt code (for t<sub>q</sub> Test Condition)
- 8** - t<sub>q</sub> code
- 9** - 0 = Eyelet terminals (Gate and Aux. Cathode Leads)  
 1 = Fast-on terminals (Gate and Aux. Cathode Leads)  
 2 = Flag terminals (For Cathode and Gate Terminals)
- 10** - Critical dv/dt:  
 None = 500V/μsec (Standard value)  
 L = 1000V/μsec (Special selection)

dv/dt - t <sub>q</sub> combinations available						
dv/dt (V/μs)		20	50	100	200	400
t <sub>q</sub> (μs)	10	CN	DN	EN	<b>FN</b> *	HN
	12	CM	DM	EM	<b>FM</b> *	HM
	15	CL	DL	EL	FL	HL
	18	CP	DP	EP	<b>FP</b> *	HP
	20	CK	DK	EK	<b>FK</b> *	HK
t <sub>q</sub> (μs)	15	CL	--	--	--	--
	18	CP	DP	EP	<b>FP</b> *	--
	20	CK	DK	EK	<b>FK</b> *	HK
	25	CJ	DJ	EJ	FJ	HJ
	30	--	DH	EH	FH	HH

\*Standard part number.  
All other types available only on request.

Outline Table

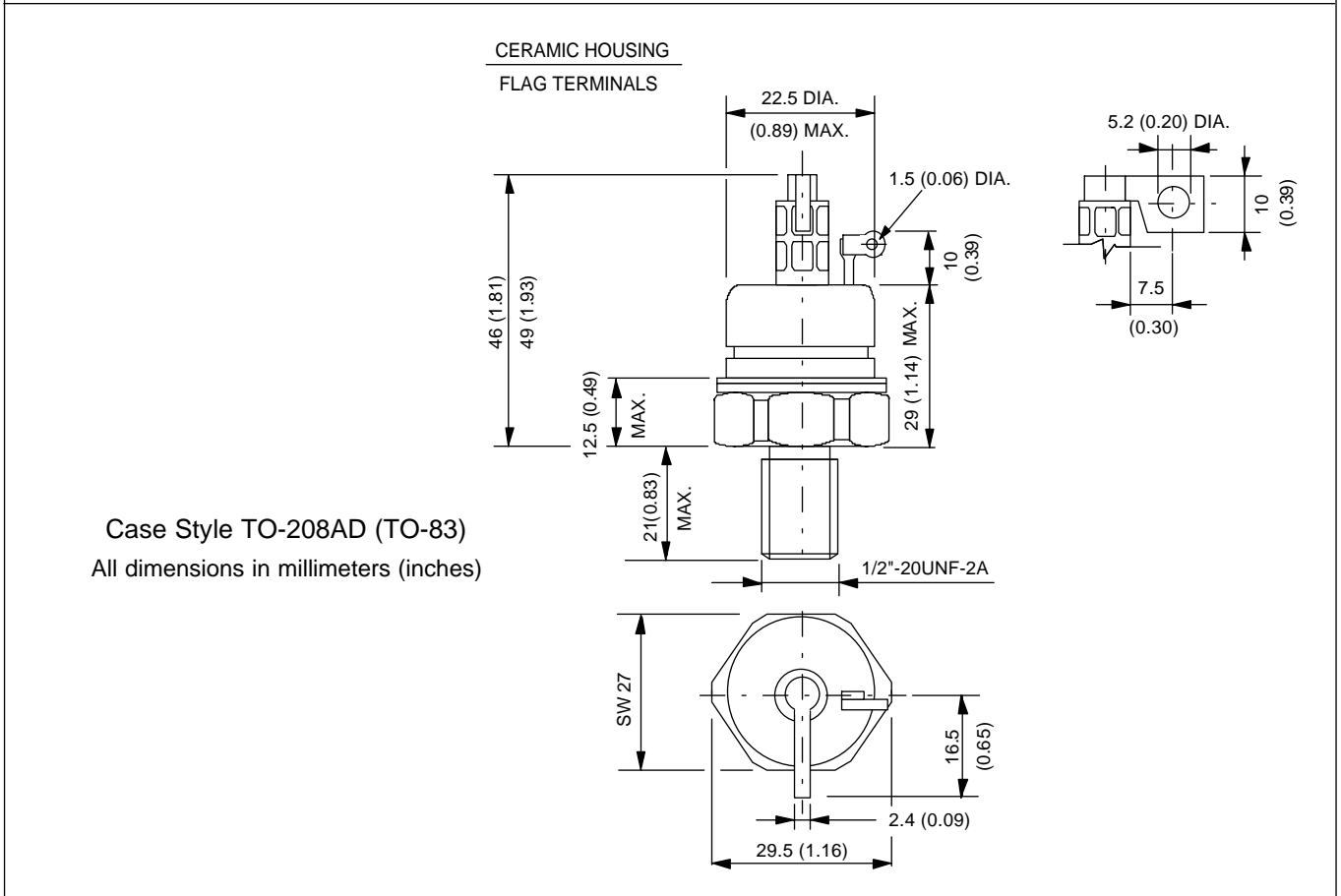
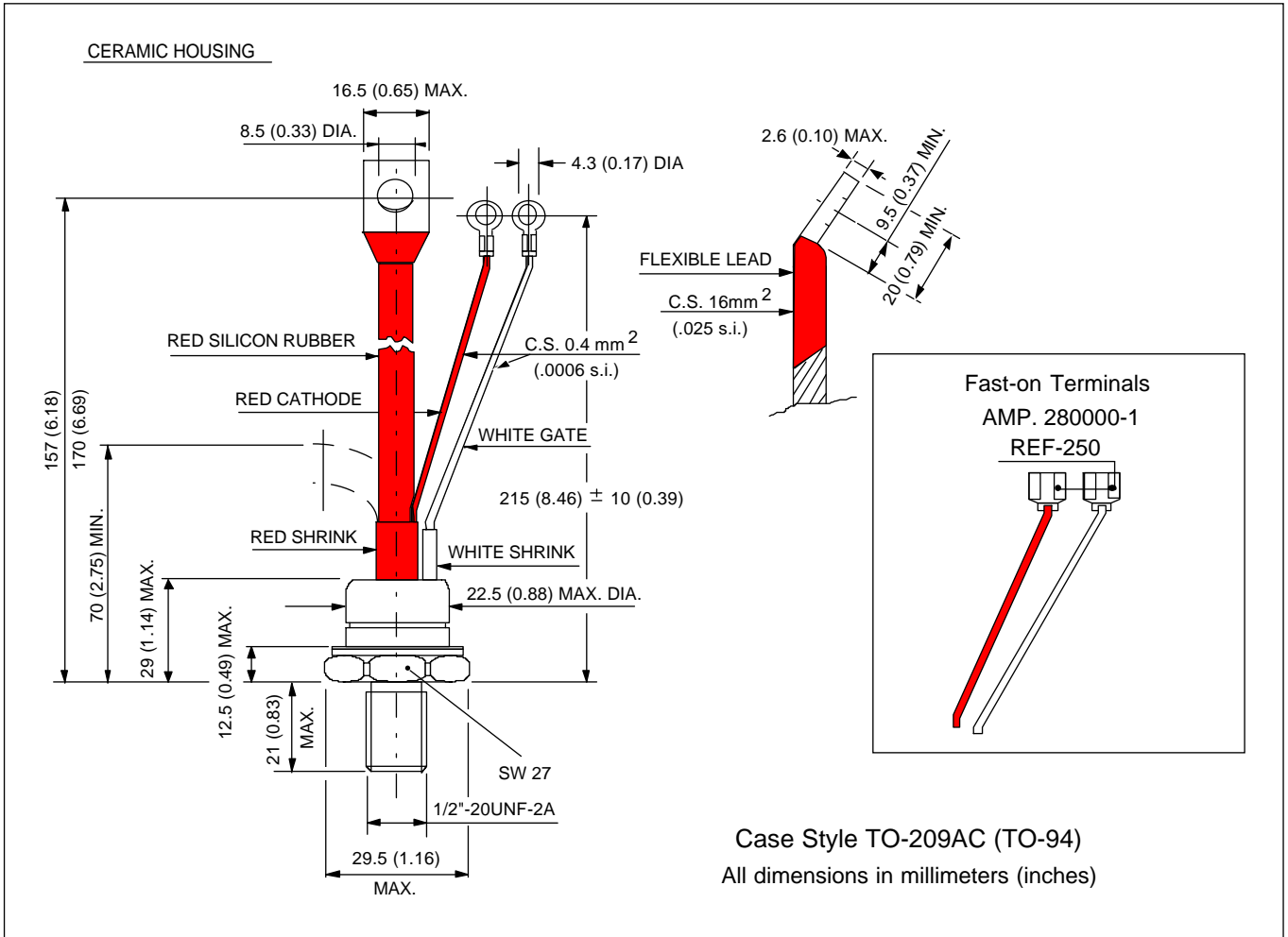

# ST083S Series

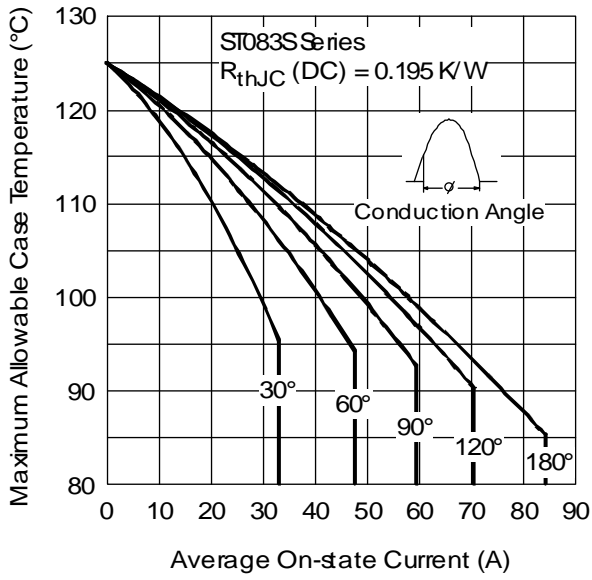

Fig. 1 - Current Ratings Characteristics

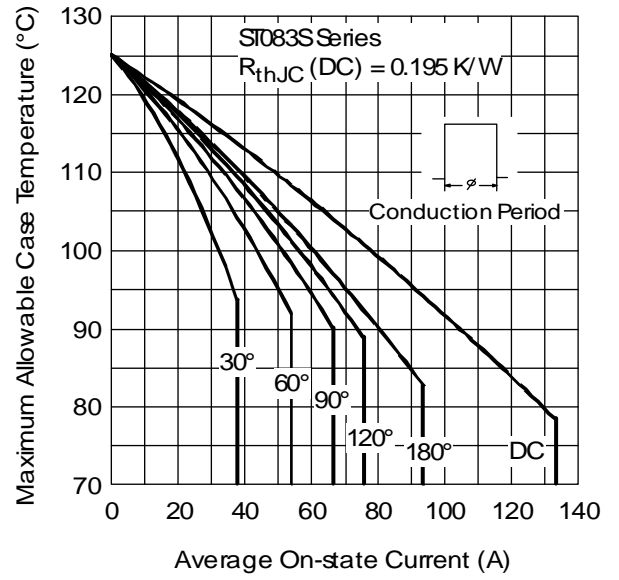

Fig. 2 - Current Ratings Characteristics

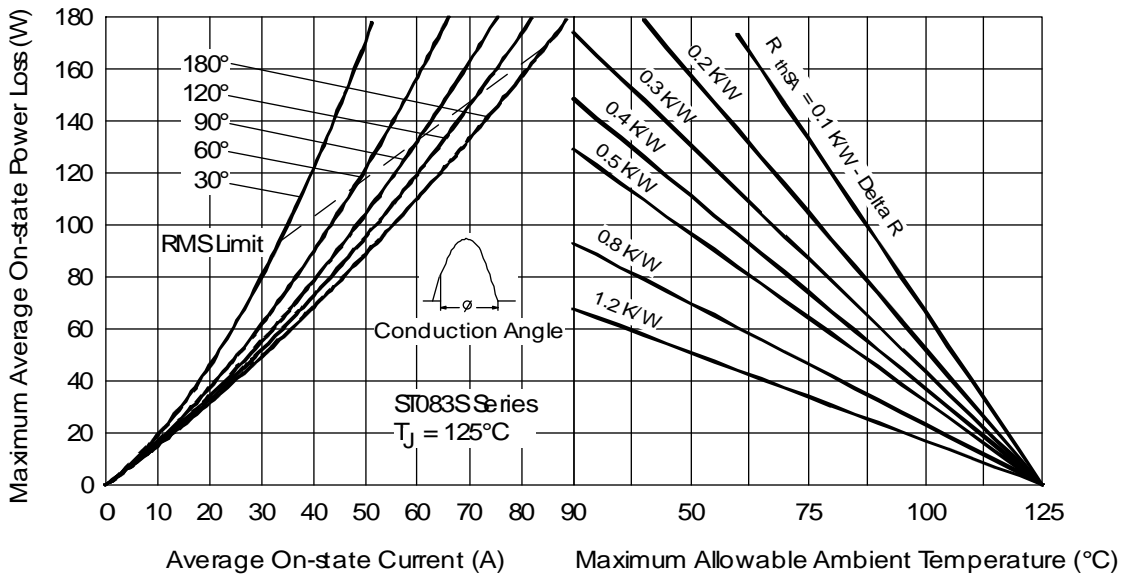

Fig. 3 - On-state Power Loss Characteristics

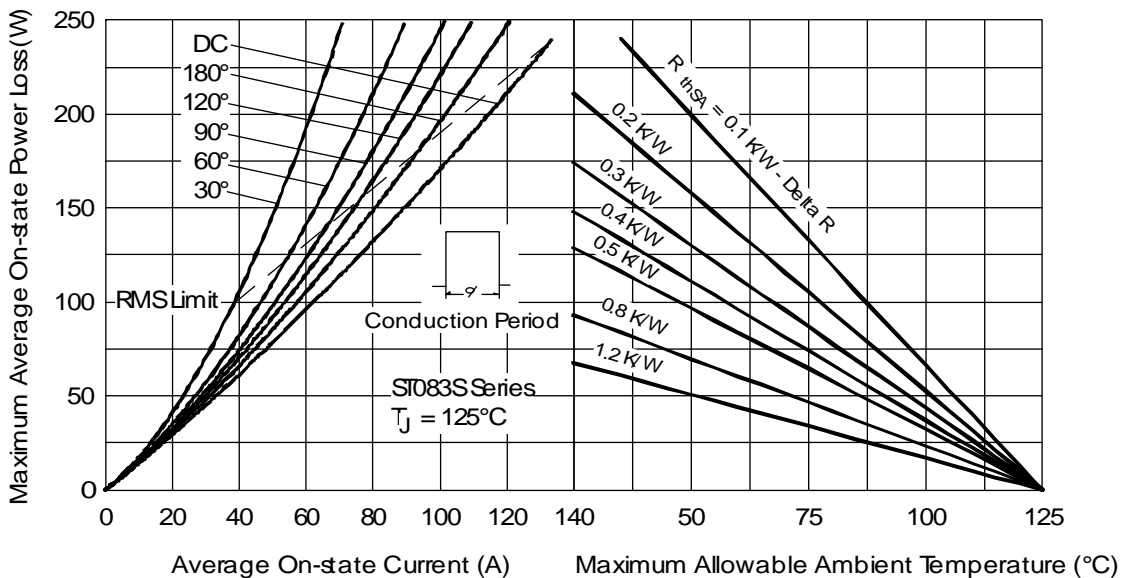

Fig. 4 - On-state Power Loss Characteristics

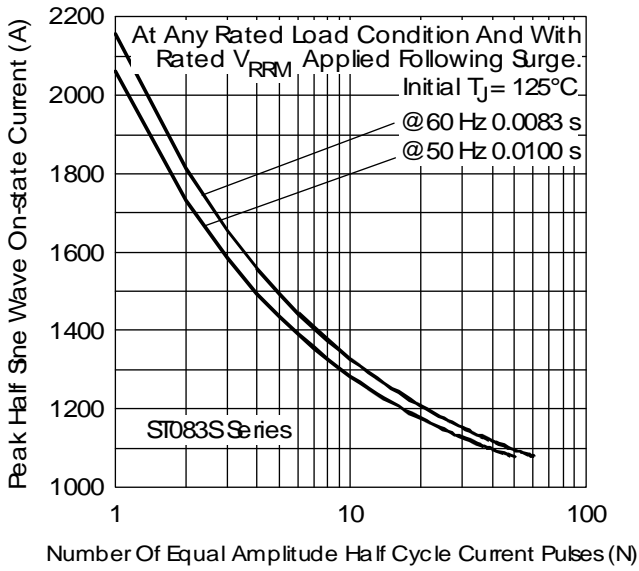

Fig. 5 - Maximum Non-repetitive Surge Current

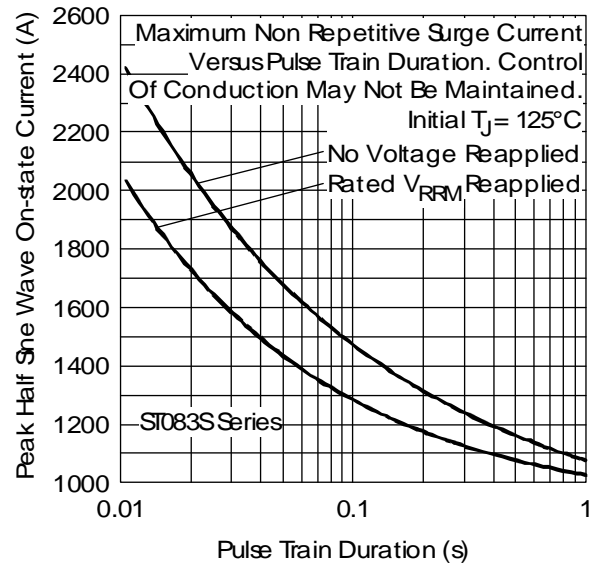

Fig. 6 - Maximum Non-repetitive Surge Current

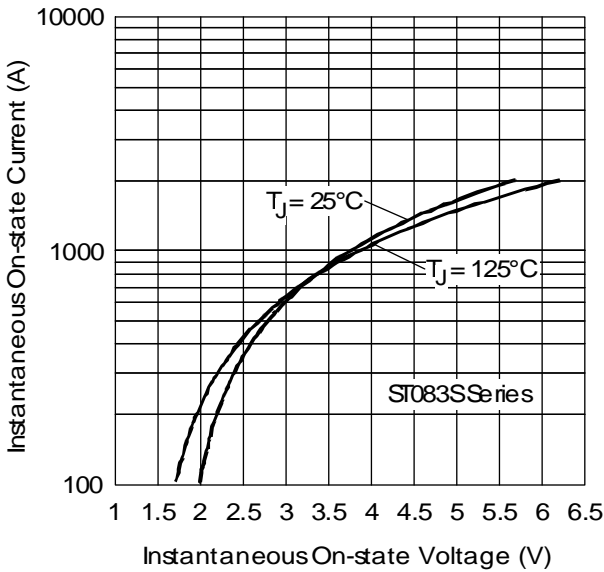

Fig. 7 - On-state Voltage Drop Characteristics

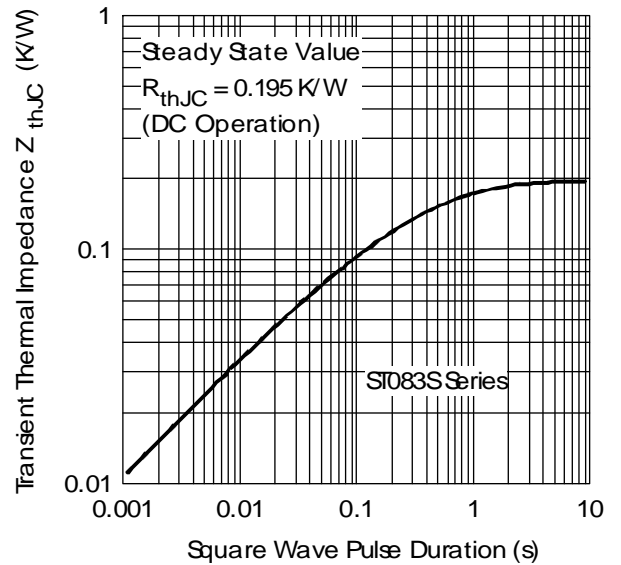

Fig. 8 - Thermal Impedance  $Z_{thJC}$  Characteristic

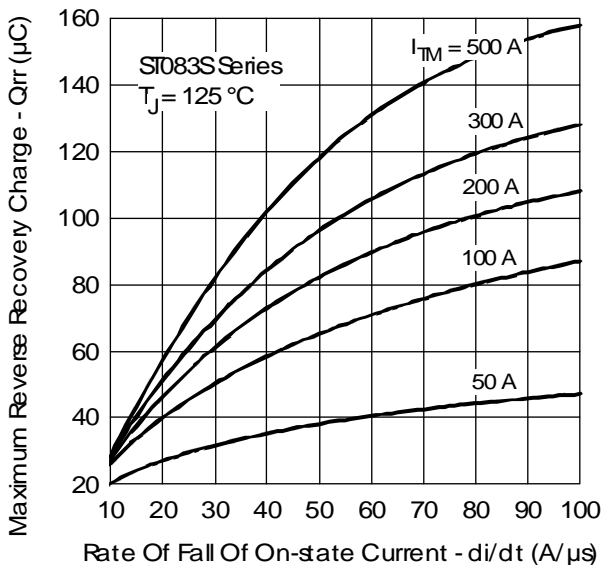

Fig. 9 - Reverse Recovered Charge Characteristics

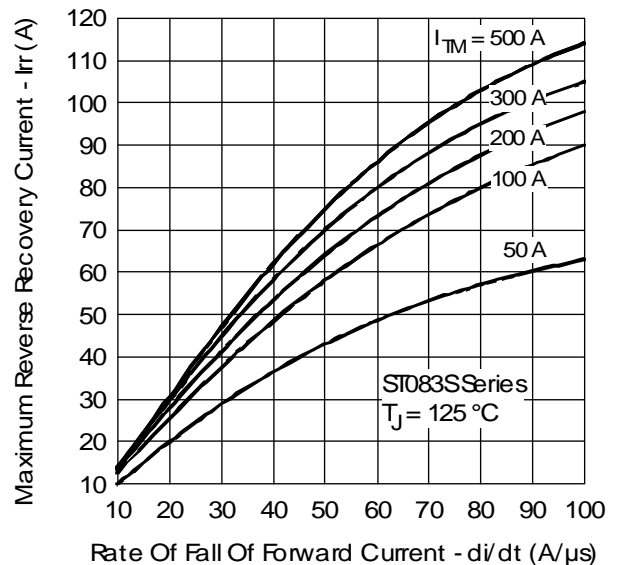

Fig. 10 - Reverse Recovery Current Characteristics

# ST083S Series

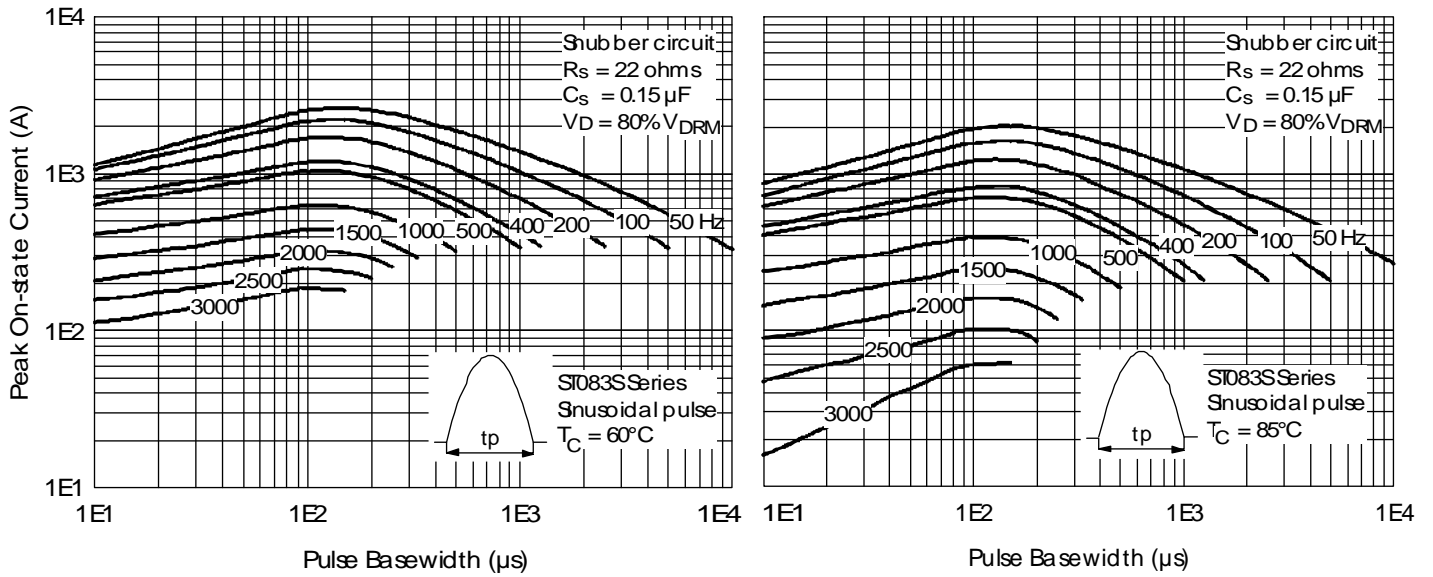

Fig. 11 - Frequency Characteristics

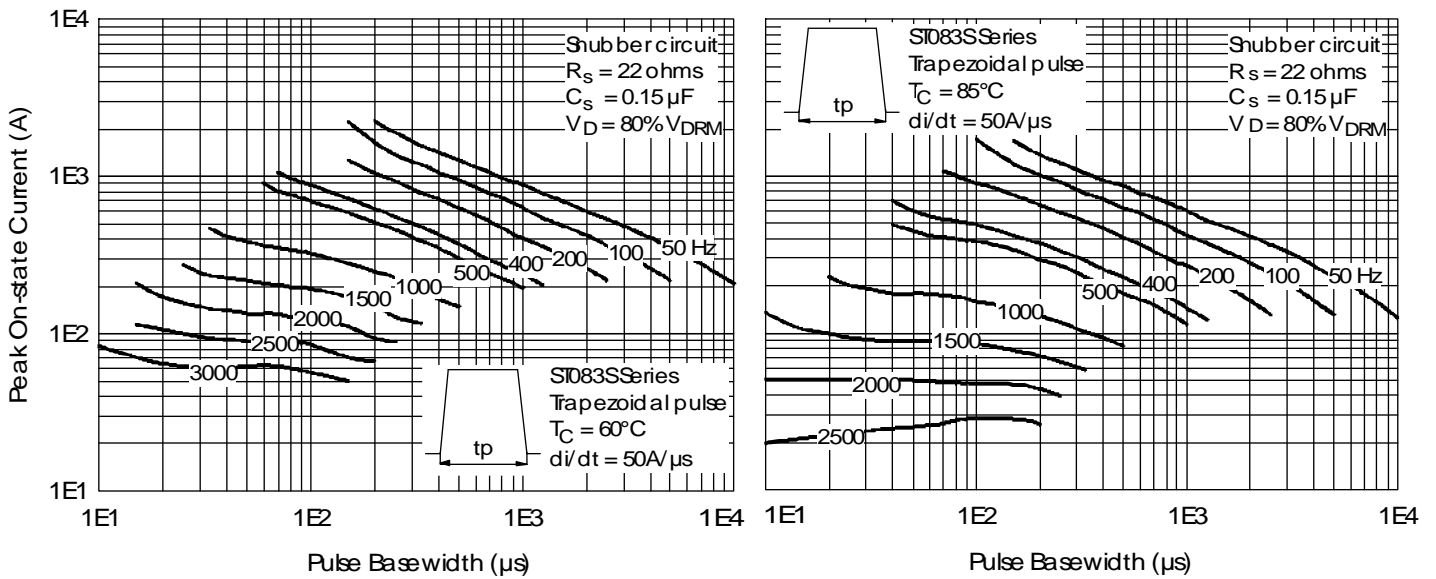

Fig. 12 - Frequency Characteristics

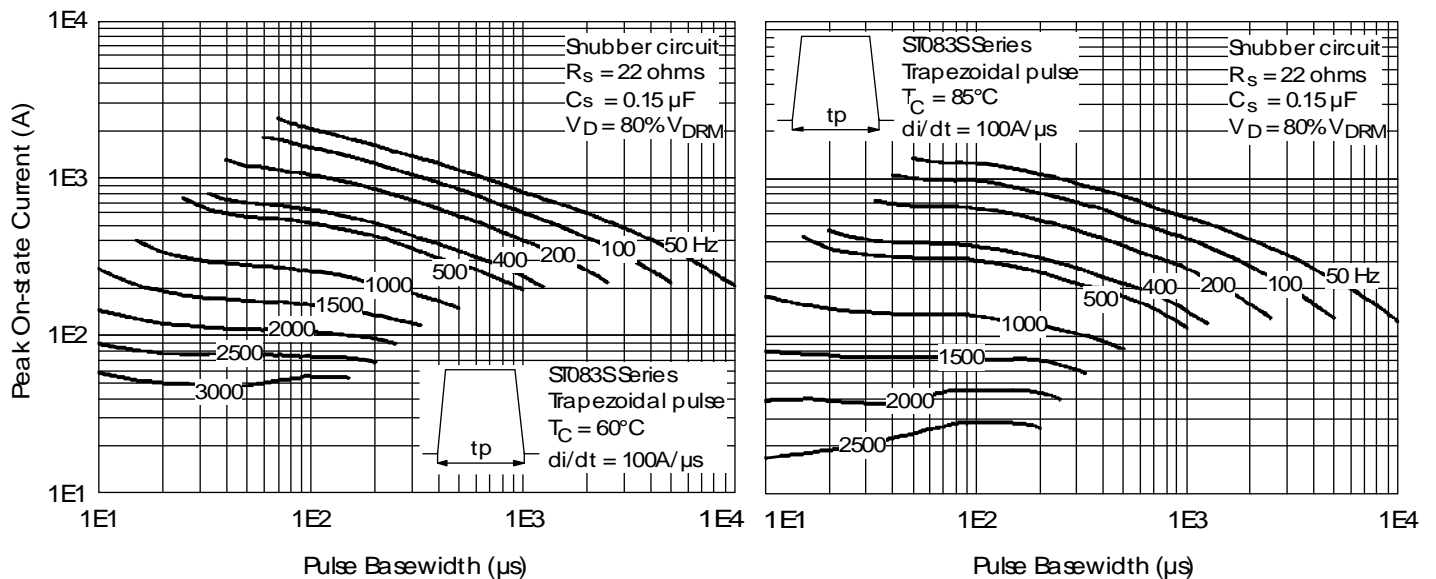

Fig. 13 - Frequency Characteristics

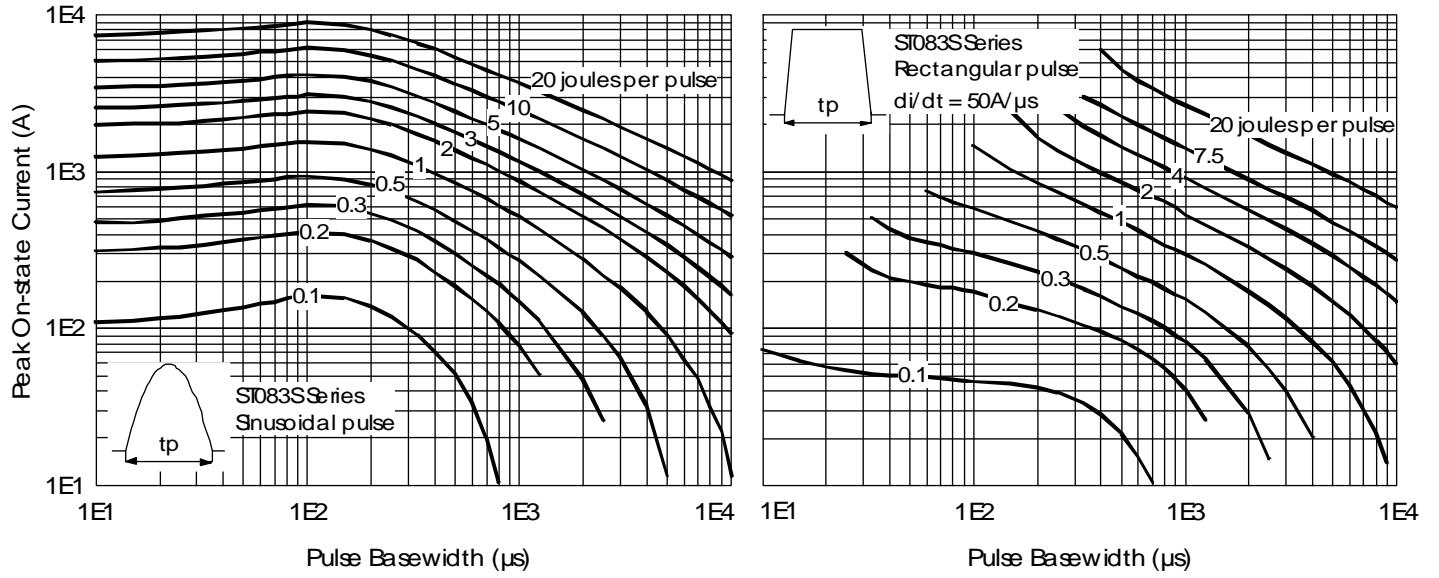

Fig. 14 - Maximum On-state Energy Power Loss Characteristics

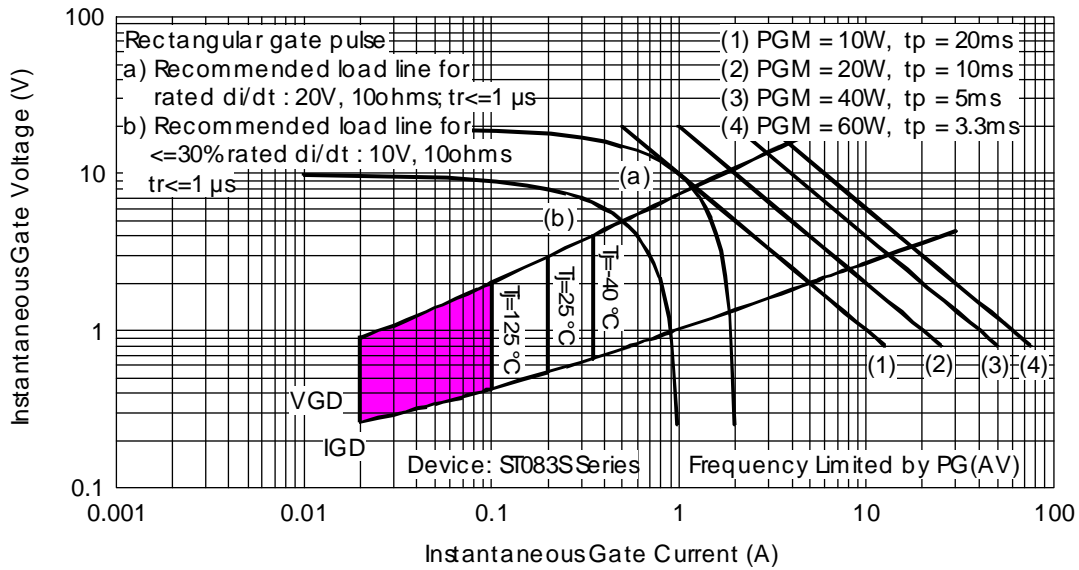

Fig. 15 - Gate Characteristics