

Remote I/O R7G4H Series

MECHATROLINK I/O MODULE

(high-speed DC voltage output, 4 points, isolated, screw terminal block, MECHATROLINK- III use)

Functions & Features

- 4 points high-speed DC voltage output for MECHATROLINK- III
- Easy parameter setting of individual channels with M-System's configurator software

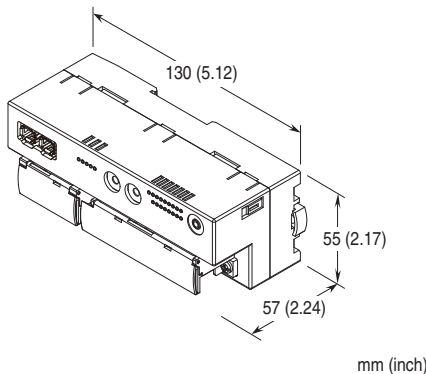

MODEL: R7G4HML3-6-YVF4-R[1]

ORDERING INFORMATION

- Code number: R7G4HML3-6-YVF4-R[1]
Specify a code from below for [1].
(e.g. R7G4HML3-6-YVF4-R/UL/Q)
- Specify the specification for option code /Q
(e.g. /C01/SET)

TERMINAL BLOCK

- 6: Screw terminal block for power supply
Connector for MECHATROLINK- III
Screw terminal block for I/O

I/O TYPE

YVF4: DC voltage output, high-speed, 4 points

POWER INPUT

DC Power

R: 24 V DC

(Operational voltage range 24 V \pm 10 %, ripple 10 %p-p max.)

[1] OPTIONS (multiple selections)

Standards & Approvals

blank: CE marking

/UL: UL approval, CE marking

Other Options

blank: none

/Q: Option other than the above (specify the specification)

SPECIFICATIONS OF OPTION: Q (multiple selections)

COATING (For the detail, refer to M-System's web site.)

/C01: Silicone coating

/C02: Polyurethane coating

/C03: Rubber coating (UL not available)

EX-FACTORY SETTING

/SET: Preset according to the Ordering Information Sheet
(No. ESU-7772-YVF4)

RELATED PRODUCTS

- PC configurator software (model: R7CFG)

Downloadable at M-System's web site.

A dedicated cable is required to connect the module to the PC. Please refer to the internet software download site or the users manual for the PC configurator for applicable cable types.

GENERAL SPECIFICATIONS

Connection

MECHATROLINK-III: MECHATROLINK-III connector

Power input, output: M3 separable screw terminal (torque 0.5 N·m)

Solderless terminal: Refer to the drawing at the end of the section.

Recommended manufacturer: Japan Solderless Terminal MFG.Co.Ltd, Nichifu Co.,Ltd

Applicable wire size: 0.25 to 1.65 mm² (AWG 22 to 16)

Screw terminal: Nickel-plated steel

Housing material: Flame-resistant resin (gray)

Isolation: Output 0 to output 1 to output 2 to output 3 to MECHATROLINK or FE to power

Zero adjustments: Configurable via R7CFG

Span adjustments: Configurable via R7CFG

Output range: Configurable via R7CFG

Output at the loss of communication: Configurable via R7CFG

Output reset value: Configurable via R7CFG

Status indicator LEDs: PWR, ERR, CON, LNK1, LNK2
(Refer to the instruction manual for details)

MODEL: R7G4HML3-6-YVF4

■ Recommended solderless terminal

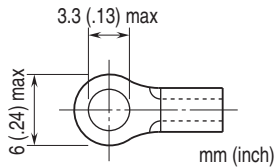

Weight: 220 g (0.49 lb)

MECHATROLINK-III COMMUNICATION

Baud rate: 100 Mbps

Transmission distance: 6300 m max.

Distance between stations: 100 m max.

Transmission media: MECHATROLINK cable (Model JEPMC-W6013-x-E, Yaskawa Controls Co., Ltd.)

Connector: TYCO AMP Industrial mini I/O connector

Max. number of slaves: 62

(The maximum number of slaves might change depending on the master unit. Refer to the manual of the master unit)

Transmission cycle: 125 μ sec., 250 μ sec., 500 μ sec., 1 - 64 msec. (with 1 msec. increments)

Communication cycle: 125 μ sec. through 64 msec.

Applicable profile: Standard I/O profile (cyclic communication)

Event-driven communication acquiring ID profile (event-driven communication)

Transmission bytes: 16 bytes

Station address: 03H through EFH (set with rotary switches)

Cyclic communication: Available

Event-driven communication: Available

Slave monitoring: None

OUTPUT SPECIFICATIONS

■ Narrow Span voltage

Output range: -1 - +1 V DC, 0 - 1 V DC, -0.5 - +0.5 V DC

Load resistance: 100 k Ω min.

■ Wide Span voltage

Output range: -10 - +10 V DC, -5 - +5 V DC, 0 - 10 V DC, 0 - 5 V DC, 1 - 5 V DC

Load resistance: 100 k Ω min.

■ Operational range

Except -10 to +10 V DC: -15 to +115 % of output range

-10 to +10 V DC: Approx. -11.5 to +11.5 V DC

INSTALLATION

Current consumption

•DC: Approx. 100 mA

Operating temperature: -10 to +55°C (14 to 131°F)

Storage temperature: -20 to +65°C (-4 to +149°F)

Operating humidity: 30 to 90 %RH (non-condensing)

Atmosphere: No corrosive gas or heavy dust

Mounting: Surface or DIN rail (35 mm rail)

PERFORMANCE

Conversion accuracy: ± 0.1 %

Conversion rate: 200 μ sec. per 4 channels

Data range: 0 - 10000 of the output range

Temp. coefficient: ± 0.015 %/°C (± 0.008 %/°F)

Output delay time: ≤ 250 μ sec. (0 - 90 %)

Insulation resistance: ≥ 100 M Ω with 500 V DC

Isolation: 1500 V AC @ 1 minute

(output 0 to output 1 to output 2 to output 3 MECHATROLINK or FE to power)

STANDARDS & APPROVALS

EU conformity:

EMC Directive

EMI EN 61000-6-4

EMS EN 61000-6-2

RoHS Directive

EN 50581

Approval:

UL/C-UL general safety requirements

(UL 61010-1, CAN/CSA-C22.2 No.61010-1-12)

(UL 61010-2-201, CAN/CSA-C22.2 No.61010-2-201)

PC CONFIGURATOR

The following parameters can be set with using PC Configurator Software (model: R7CFG)

Refer to the users manual for the R7CFG for detailed operation of the software program.

■ SETTINGS FOR INDIVIDUAL CHANNELS

PARAMETER	SETTING RANGE	DEFAULT SETTING
Validating/ Invalidating	Valid Invalid	Valid
Output range	-10 - +10 V DC -5 - +5 V DC -1 - +1 V DC 0 - 10 V DC 0 - 5 V DC 1 - 5 V DC 0 - 1 V DC -0.5 - +0.5 V DC	-10 - +10 V DC
Bias adjustment	-320.00 - +320.00 (%)	0.00 (%)
Gain adjustment	-3.2000 - +3.2000	1.0000
Zero scale	-32 000 - +32 000	0
Full scale	-32 000 - +32 000	10 000
Output reset value*1	-15.00 - +115.00 (%)	-15.00 (%)

■ SETTINGS FOR ALL CHANNELS

PARAMETER	SETTING RANGE	DEFAULT SETTING
Setting indication for output function at the loss of communication	Hold the output Output reset value	Hold the output

*1. When output range is -10 - +10 V DC, approx. -115 V DC at approx. -7.5 - -15% and approx. +11.5 V DC at approx. 107.5 - 115% are outputted respectively.

EXTERNAL VIEW

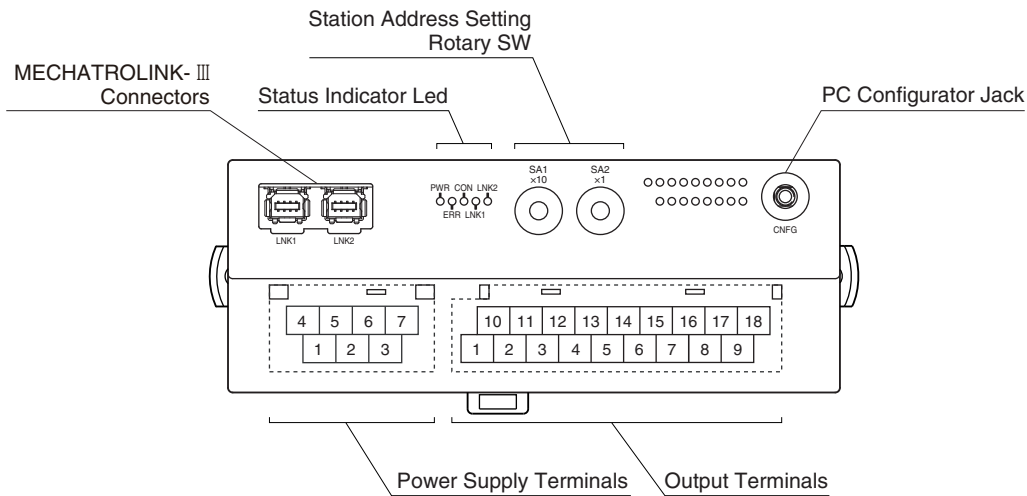

TERMINAL ASSIGNMENTS

OUTPUT TERMINAL ASSIGNMENT

10	11	12	13	14	15	16	17	18
NC	VH0	NC	VH1	NC	VH2	NC	VH3	NC
1	2	3	4	5	6	7	8	9
NC	COM0	VL0	COM1	VL1	COM2	VL2	COM3	VL3

NO.	ID	FUNCTION	NO.	ID	FUNCTION
1	NC	No connection	10	NC	No connection
2	COM0	Common 0	11	VH0	Wide span vlot. 0
3	VL0	Narrow span volt. 0	12	NC	No connection
4	COM1	Common 1	13	VH1	Wide span vlot. 1
5	VL1	Narrow span volt. 1	14	NC	No connection
6	COM2	Common 2	15	VH2	Wide span vlot. 2
7	VL2	Narrow span volt. 2	16	NC	No connection
8	COM3	Common 3	17	VH3	Wide span vlot. 3
9	VL3	Narrow span volt. 3	18	NC	No connection

POWER SUPPLY TERMINAL ASSIGNMENT

4	5	6	7
NC	NC	+24V	0V
1	2	3	
NC	NC	FE	

- 1. NC
- 2. NC
- 3. FE Functional earth
- 4. NC
- 5. NC
- 6. +24V Power supply (24V DC)
- 7. 0V Power supply (0V)

MECHATROLINK RELATED COMMANDS

Commands available with the unit are as follow.

PROFILE	COMMAND	CODE	FUNCTION
Common command	NOP	00H	No operation command
	ID_RD	03H	Read ID command
	CONFIG	04H	Setup device command
	ALM_RD	05H	Read alarm or warning command
	ALM_CLR	06H	Clear alarm or warning command
	CONNECT	0EH	Establish connection command
	DISCONNECT	0FH	Release connection command
Standard I/O profile	DATA_RWA	20H	Transmit I/O data

DATA CONVERSION

■ OUTPUT RANGE AND DATA CONVERSION (FACTORY DEFAULT SETTING)

Discrete output data is converted into analog representations of 0 – 100% proportional to each scaled range.

Overrange output is possible from -15 to +115% of the nominal range.

When the signal exceeds the limit, the data is fixed at -15% or +115%.

(approx. -11.5 V or 11.5 V when the output range is -10 - +10 V)

- Output Range 0 – 5V DC

Digital Value, Decimal	Digital Value, HEX	Output Value, Engineering Unit	Output value, %
-1500	FA24	≤ -0.75V	-15%
0	0	0V	0%
10000	2710	5V	100%
11500	2CEC	≥ 5.75V	115%

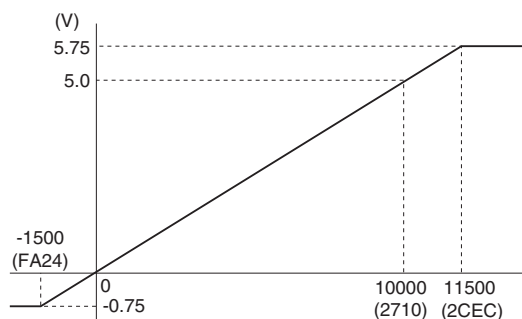

RESPONSE TIME

Response time of analog output module is time form when 0 to 100% stepwise signal change is received by the communication ASIC of the module (slave) till when the analog output signal reaches 90%.

T_{COM} : MECHATROLINK-III transmission cycle set at master
(depends on system and configuration)

T_{OUT} : Output module response time \leq Output internal processing delay time (T_d) (one minimum transmission cycle the unit can handle) + Conversion rate (T_e) + Output Delay time (T_f)

E.g.: MECHATROLINK-III transmission cycle of 1 msec.

Output module response time (T_{OUT}): Output internal processing delay time (0.125 msec.) Conversion rate (0.2 msec.) + Output Delay time (0.25 msec.) = 0.575 [msec.]

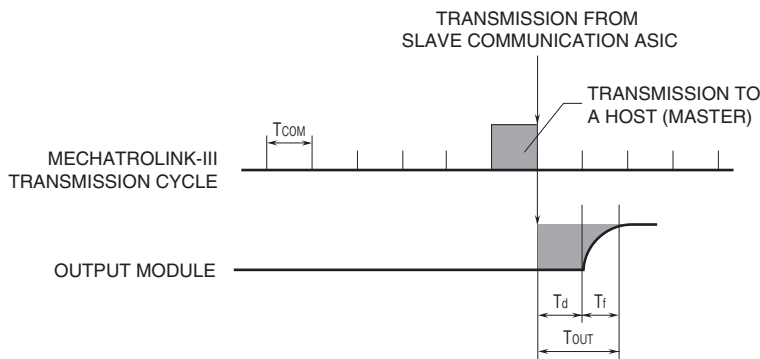

I/O DATA DESCRIPTIONS

Scaling of analog output module is configurable with the configurator software (model: R7CFG). Refer to the software manual for details.

ANALOG OUTPUT

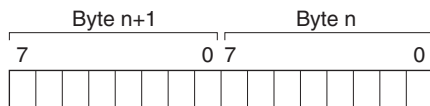

Data is represented in 16-bit binary. Negative value is represented in 2's complements.

STATUS

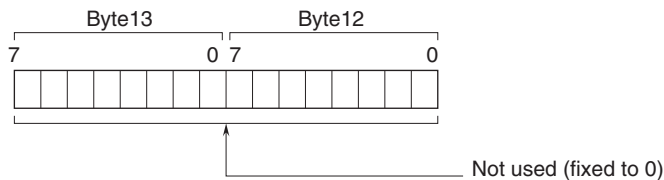

MODEL: R7G4HML3-6-YVF4

EXTERNAL DIMENSIONS & TERMINAL ASSIGNMENTS unit: mm (inch)

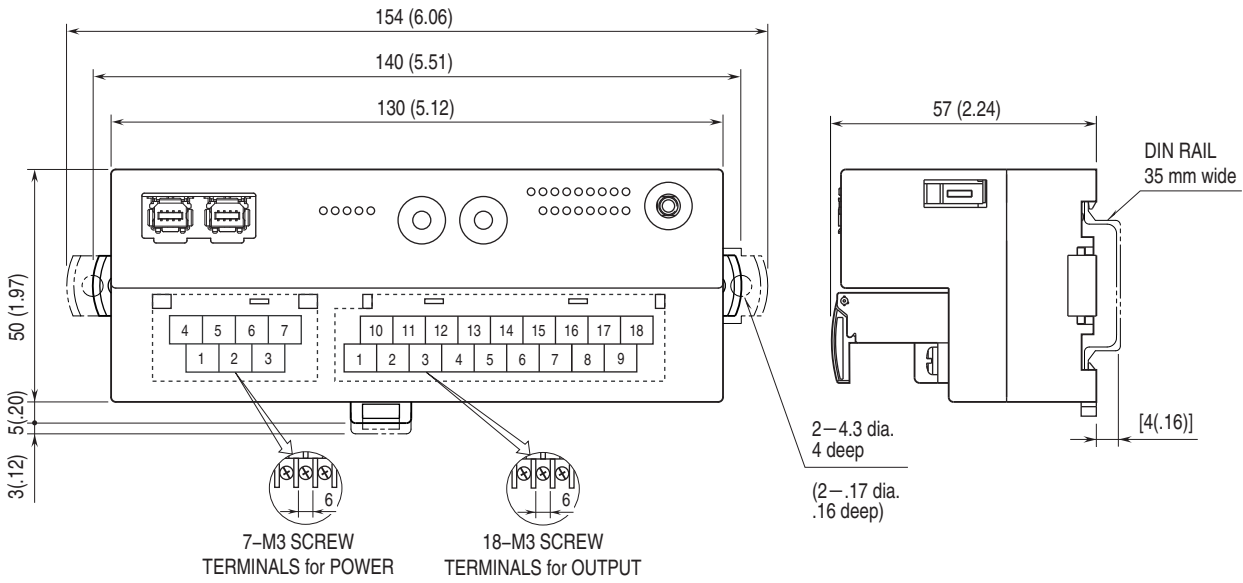

MOUNTING REQUIREMENTS unit: mm (inch)

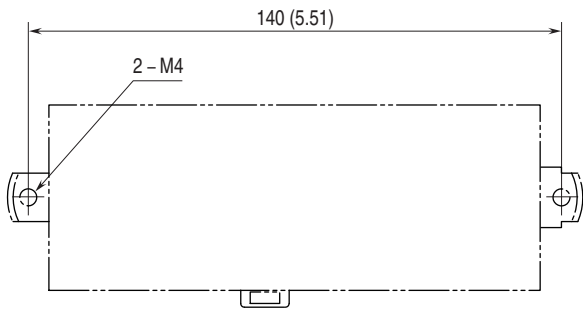

SCHEMATIC CIRCUITRY & CONNECTION DIAGRAM

Note: In order to improve EMC performance, bond the FE terminal to ground.

Caution: FE terminal is NOT a protective conductor terminal.

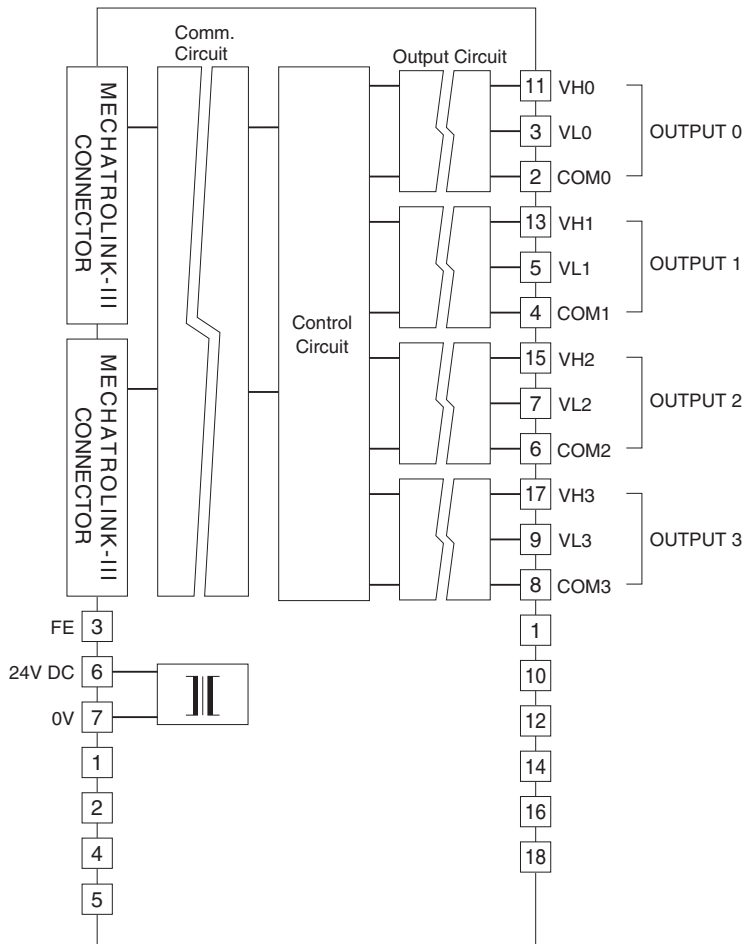

Output Connection Examples

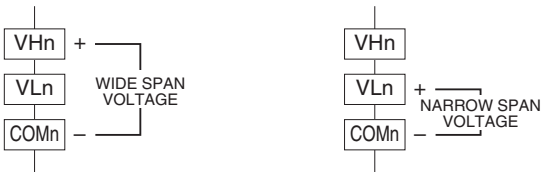

Specifications are subject to change without notice.