

0° (Hatched=NO)

| TER | ANG | (20°) | (15°) | (15°) | (20°) |
|-----|-----|-------|-------|-------|-------|
| ① | | | | | |
| ② | | | | | |
| ③ | | | | | |

CCW ————— CW

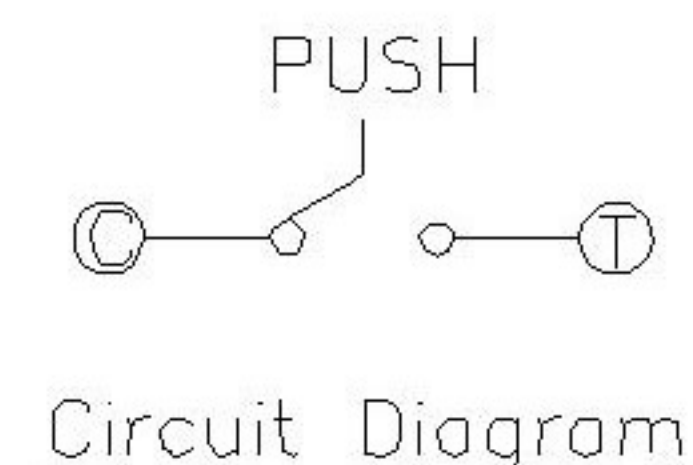

NOTE:
 Operating Force.
 lever portion 100 ± 30 gf
 Push portion 205 ± 50 gf

CODE TABLE

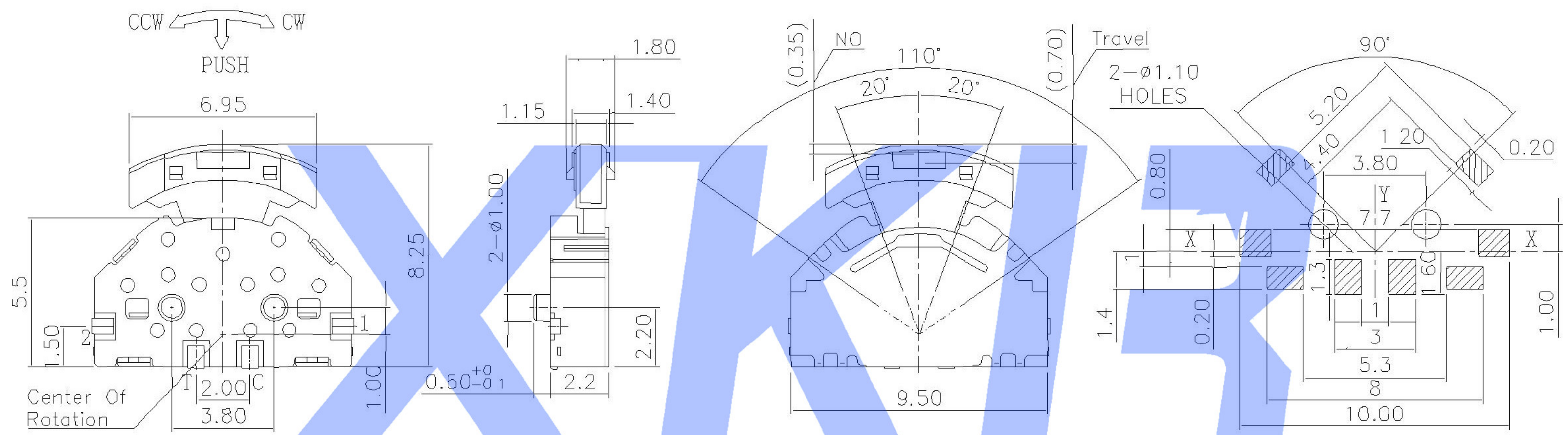

P C B Mounting
Pattern Dimension

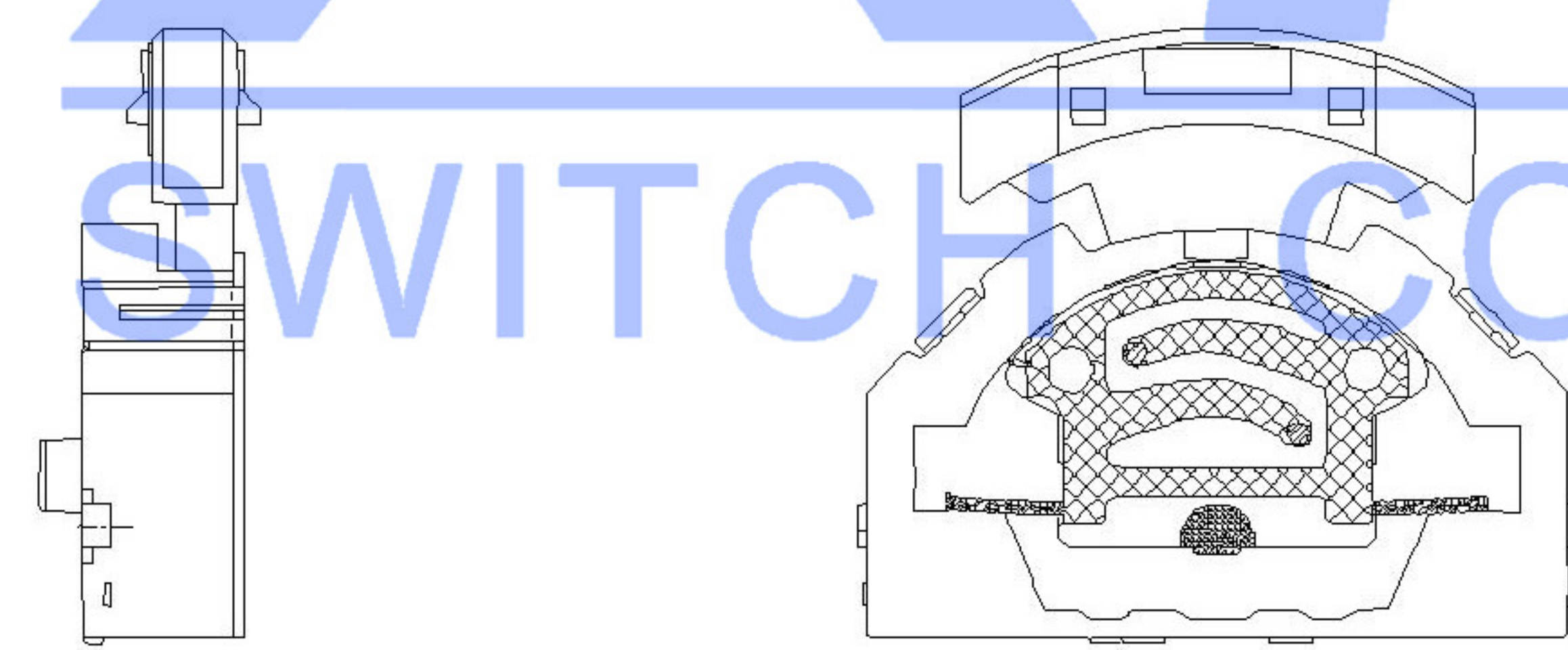

| ITEM | PAPT NAMF | TER,NO | QTY | MATERIAL | FINISHING | REMARK |
|------|-----------|--------|-----|--------------|----------------|--------|
| ⑥ | Terminal | — | 4 | Brass(0.15t) | Plating silver | — |
| ⑤ | Contact | — | 1 | F.ag/Brass | Plating silver | — |
| ④ | Base | — | 1 | Nylon | | — |
| ③ | Spring | — | 1 | Sus | Natural | — |
| ② | Cover | — | 1 | Sus | Natural | — |
| ① | Keystake | — | 1 | Nylon | | — |

| MARK | DESCRIPTION | DATE | REVISED | APPROVED | ANGULAR | ±5° | DSND | DATE | SCALE: N/A | MODEL TYPE: MULTI-FUNCTIONAL SWITCH | | |
|---|-------------|------|---------|----------|---------|---------|------------------------|------|------------|--|--------------|----------------|
| Δx | | | | | X.X | ±0.2mm | DWN | DATE | VIEW: | PART NO.: | | |
| Δx | | | | | X.XX | ±0.1mm | CHKD | DATE | UNIT: mm | DWG NO.: | | |
| Δx | | | | | X.XXX | ±0.05mm | APPD | DATE | SIZE: A4 | TM-2024 | | |
| REVISIONS | | | | | | | UNSPECIFIED TOLERANCES | | | XKB INDUSTRIAL PRECISION CO.,LIMITED | | |
| www.xk-dg.cn www.helloxkb.com www.helloxkb.cn | | | | | | | | | | WEIGHT 1.0g | SHEET 1/1 | REVISION A0 |