

SPS-9110FG / SPS-9110AFG (RoHS Compliant)

3.3V / 1310 nm / 2.125 Gbps LC SFP SINGLE-MODE TRANSCEIVER

FEATURES

- | Hot-Pluggable SFP Footprint LC Optical Transceiver
- | Small Form-Factor Pluggable (SFP) MSA compatible
- | Compliant with Fibre Channel 1X/2X SM-LC-L FC-PI
- | Compliant with IEEE 802.3z 1000BASE-LX
- | 1310 nm LD Transmitter
- | Distance up to 10 km
- | AC/AC Coupling according to MSA
- | Single +3.3 V Power Supply
- | RoHS Compliant
- | -10 to 85°C Operation: SPS-9110FG
- | -40 to 85°C Operation: SPS-9110AFG
- | Class 1 Laser International Safety Standard IEC 60825 Compliant

APPLICATIONS

- | ATM Switches and Routers
- | SONET / SDH Switch Infrastructure
- | XDSL Applications
- | Metro Edge Switching

DESCRIPTION

The SPS-9110FG series single mode transceivers is small form factor pluggable module for bi-directional serial optical data communications such as Gigabit Ethernet 1000BASE-LX and Fibre Channel 1x/2x SM-LC-L FC-PI. It is with the SFP 20-pin connector to allow hot plug capability. This module is designed for single mode fiber and operates at a nominal wavelength of 1310 nm. The transmitter section uses a multiple quantum well laser and is a class 1 laser compliant according to International Safety Standard IEC-60825. The receiver section uses an integrated InGaAs detector preamplifier (IDP) mounted in an optical header and a limiting post-amplifier IC.

LASER SAFETY

This single mode transceiver is a Class 1 laser product. It complies with IEC 60825 and FDA 21 CFR 1040.10 and 1040.11. The transceiver must be operated within the specified temperature and voltage limits. The optical ports of the module shall be terminated with an optical connector or with a dust plug.

ORDER INFORMATION

| P/No. | Bit Rate (Gb/s) | FC-PI | Distance (km) | Wavelength (nm) | Package | Temp. (°C) | TX Power (dBm) | RX Sens. (dBm) | RoHS Compliant |
|-------------|-----------------|---------|---------------|-----------------|---------|------------|----------------|----------------|----------------|
| SPS-9110FG | 2.125/1.063 | 200/100 | 10 | 1310 | LC SFP | -10 to 85 | -3 to -8 | -21 | Yes |
| SPS-9110AFG | 2.125/1.063 | 200/100 | 10 | 1310 | LC SFP | -40 to 85 | -3 to -8 | -21 | Yes |

| Absolute Maximum Ratings | | | | | |
|----------------------------|--------|------------|----------|-------|---------------------------|
| Parameter | Symbol | Min | Max | Units | Notes |
| Storage Temperature | Tstg | -40 | 85 | °C | |
| Operating Case Temperature | Topr | -10 -40 | 85 85 | °C | SPS-9110FG SPS-9110AFG |
| Power Supply Voltage | Vcc | -0.5 | 3.6 | V | |

| Recommended Operating Conditions | | | | | |
|----------------------------------|------------|------------|------|----------|-------------------------------------|
| Parameter | Symbol | Min | Typ | Max | Units / Notes |
| Power Supply Voltage | Vcc | 3.1 | 3.3 | 3.5 | V |
| Operating Case Temperature | Topr | -10 -40 | | 85 85 | °C / SPS-9110FG °C / SPS-9110AFG |
| Power Supply Current | ICC(TX+RX) | | 200 | 300 | mA |
| Data Rate | | 1000 | 2125 | | Mb/s |

| Transmitter Specifications (-10°C < Topr < 85°C, 3.1V < Vcc < 3.5V) | | | | | | |
|---|-----------------------------------|------|------|----------------------|---------|--------------------|
| Parameter | Symbol | Min | Typ | Max | Units | Notes |
| Optical | | | | | | |
| Optical Transmit Power | Po | -8 | --- | -3 | dBm | 1 |
| Output Center Wavelength | λ | 1270 | 1310 | 1350 | nm | |
| Output Spectrum Width | $\Delta\lambda$ | --- | --- | 2.5 | nm | RMS (σ) |
| Extinction Ratio | ER | | 9 | --- | dB | |
| Optical Modulation Amplitude (Peak-to-Peak) | OMA | 174 | | | μ W | FC-PI Standard |
| Optical Rise Time | t_r | | | 160 | ps | 20 % to 80% Values |
| Optical Fall Time | t_f | | | 160 | ps | 20 % to 80% Values |
| Relative Intensity Noise | RIN | | | -120 | dB/Hz | |
| Electrical | | | | | | |
| Data Input Current – Low | I _{IL} | -350 | | | μ A | |
| Data Input Current – High | I _{IH} | | | 350 | μ A | |
| Differential Input Voltage | V _{IH} - V _{IL} | 0.5 | | 2.4 | V | Peak-to-Peak |
| TX Disable Input Voltage – Low | T _{DIS, L} | 0 | | 0.5 | V | 2 |
| TX Disable Input Voltage – High | T _{DIS, H} | 2.0 | | V _{cc} | V | 2 |
| TX Disable Assert Time | T _{ASSERT} | | | 10 | μ s | |
| TX Disable Deassert Time | T _{DEASSERT} | | | 1 | ms | |
| TX Fault Output Voltage -- Low | T _{FaultL} | 0 | | 0.8 | V | 3 |
| TX Fault Output Voltage -- High | T _{FaultH} | 2.0 | | V _{cc} +0.3 | V | 3 |

1. Output power is power coupled into a 9/125 μ m single mode fiber.
2. There is an internal 4.7K to 10K ohm pull-up resistor to VccTX.
3. Open collector compatible, 4.7K to 10K ohm pull-up to Vcc (Host Supply Voltage).

| Receiver Specifications (-10°C < Topr < 85°C, 3.1V < Vcc < 3.5V) | | | | | | |
|--|-----------------------------------|------|-----|----------------------|-------|-------------------------|
| Parameter | Symbol | Min | Typ | Max | Units | Notes |
| Optical | | | | | | |
| Sensitivity @2.125Gb/s @ BER=10 ⁻¹² | SENS (2X) | --- | --- | -21 | dBm | 4 |
| Sensitivity @1.25Gb/s @ BER=10 ⁻¹² | SENS (1X) | | | -22 | dBm | 4 |
| Maximum Input Power | Pin | -3 | | | dBm | 4 |
| Signal Detect -- Asserted | Pa | --- | | -21 | dBm | Transition: low to high |
| Signal Detect -- Deasserted | Pd | -30 | --- | --- | dBm | Transition: high to low |
| Signal detect -- Hysteresis | | 1.0 | --- | | dB | |
| Wavelength of Operation | | 1100 | --- | 1600 | nm | |
| Electrical | | | | | | |
| Differential Output Voltage | V _{OH} - V _{OL} | 0.6 | | 2.0 | V | |
| Output LOS Voltage -- Low | V _{OL} | 0 | | 0.8 | V | 5 |
| Output LOS Voltage -- High | V _{OH} | 2.0 | | V _{cc} +0.3 | V | 5 |

4. Measured at 2⁻¹-1 PRBS at BER 1E-12 @ 1300 nm.
5. Open collector compatible, 4.7K to 10K ohm pull-up to Vcc (Host Supply Voltage).

CONNECTION DIAGRAM

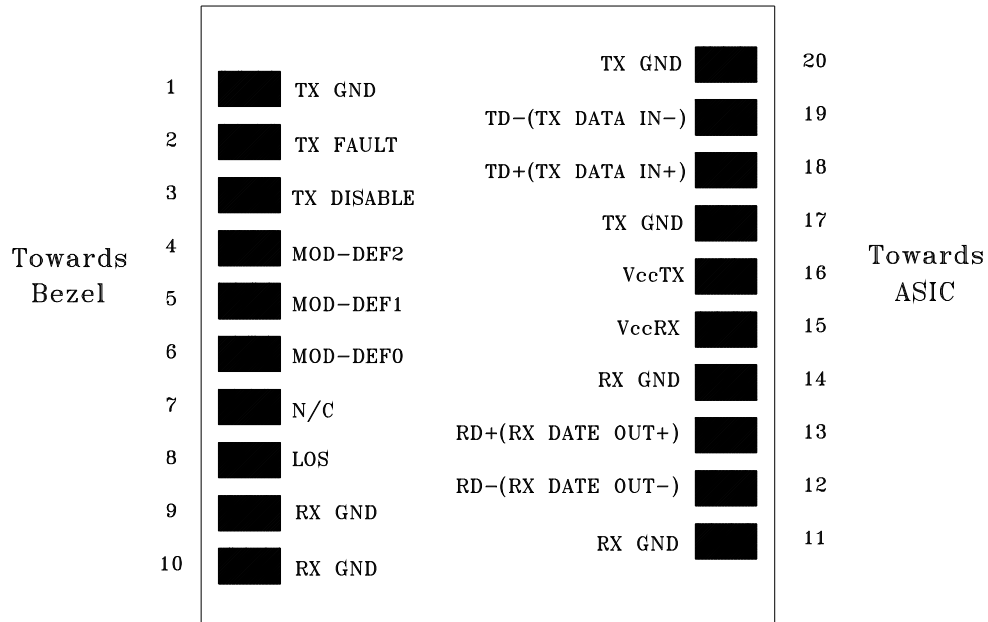

| PIN | Signal Name | Description | PIN | Signal Name | Description |
|-----|-------------|---|-----|--------------|-----------------------------|
| 1 | TX GND | Transmitter Ground | 11 | RX GND | Receiver Ground |
| 2 | TX Fault | Transmitter Fault Indication | 12 | RX DATA OUT- | Inverse Receiver Data Out |
| 3 | TX Disable | Transmitter Disable (Module disables on high or open) | 13 | RX DATA OUT+ | Receiver Data Out |
| 4 | MOD-DFE2 | Modulation Definition 2 – Two wires serial ID Interface | 14 | RX GND | Receiver Ground |
| 5 | MOD-DEF1 | Modulation Definition 1 – Two wires serial ID Interface | 15 | Vcc RX | Receiver Power – 3.3V±5% |
| 6 | MOD-DEF0 | Modulation Definition 0 – Ground in Module | 16 | Vcc TX | Transmitter Power – 3.3V±5% |
| 7 | N/C | Not Connected | 17 | TX GND | Transmitter Ground |
| 8 | LOS | Loss of Signal | 18 | TX DATA IN+ | Transmitter Data In |
| 9 | RX GND | Receiver Ground | 19 | TX DATA IN- | Inverse Transmitter Data In |
| 10 | RX GND | Receiver Ground | 20 | TX GND | Transmitter Ground |

Module Definition

| Module Definition | MOD-DEF2 PIN 4 | MOD-DEF1 PIN 5 | MOD-DEF0 PIN 6 | Interpretation by Host |
|-------------------|-------------------|-------------------|-------------------|-----------------------------------|
| 4 | SDA | SCL | LV-TTL Low | Serial module definition protocol |

Module Definition 4 specifies a serial definition protocol. For this definition, upon power up, MOD-DEF(1:2) appear as no connector (NC) and MOD-DEF(0) is TTL LOW. When the host system detects this condition, it activates the serial protocol. The protocol uses the 2-wire serial CMOS E²PROM protocol of the ATMEL AT24C01A/02/04 family of components.

RECOMMENDED CIRCUIT SCHEMATIC

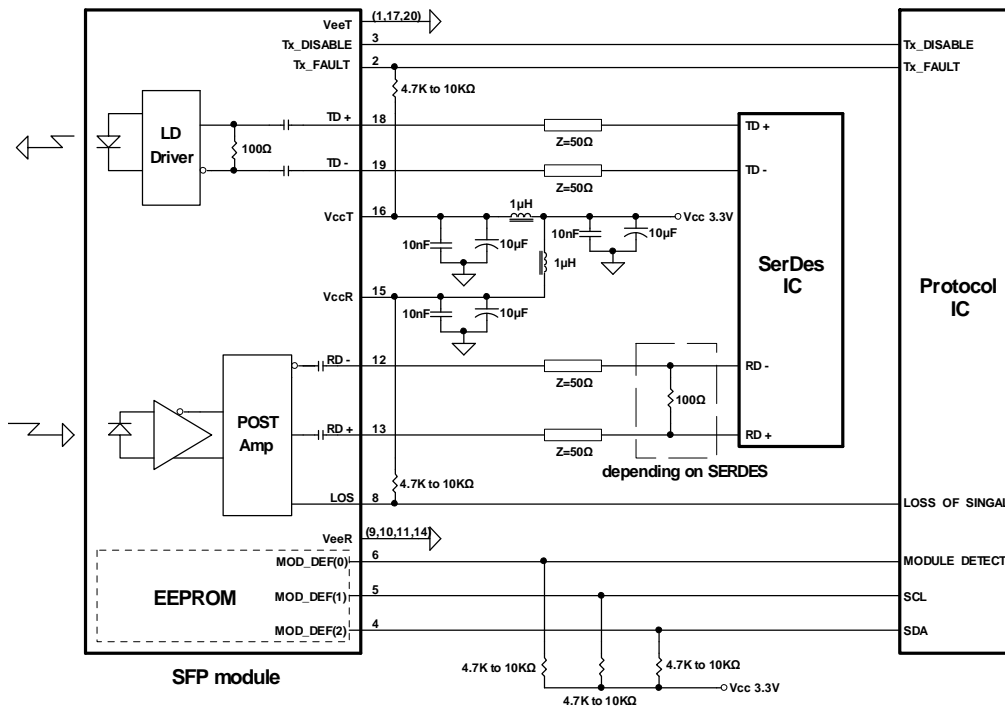

PACKAGE DIAGRAM

Units in mm

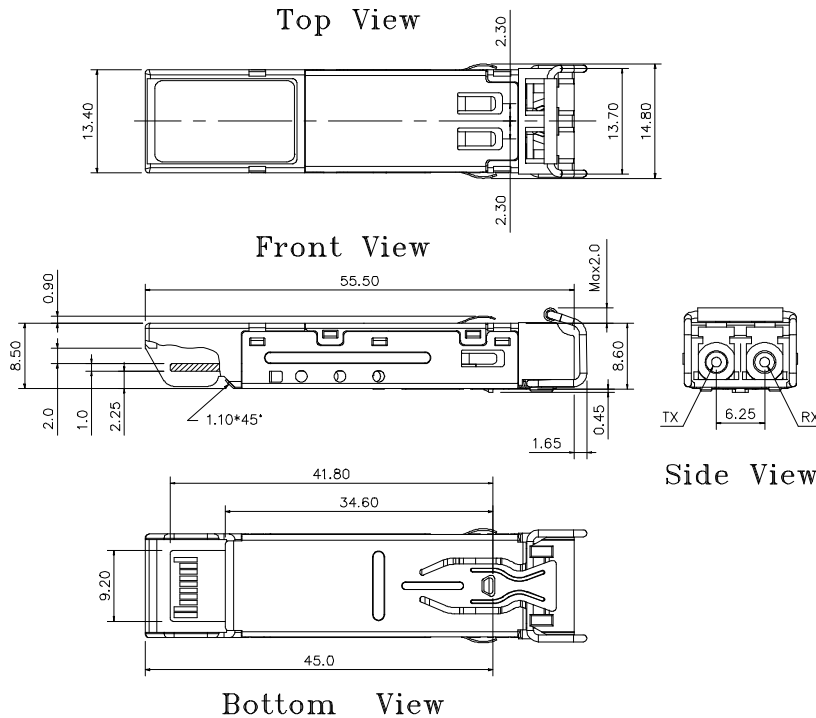

Note: Specifications subject to change without notice.