

DATA SHEET

ER9.5/2.5/5

Planar ER cores and accessories

Supersedes data of September 2004

2008 Sep 01



FERROXCUBE
A YAGEO COMPANY

CORE SETS

Effective core parameters

SYMBOL	PARAMETER	VALUE	UNIT
$\Sigma(l/A)$	core factor (C1)	1.67	mm ⁻¹
V_e	effective volume	120	mm ³
l_e	effective length	14.2	mm
A_e	effective area	8.47	mm ²
A_{min}	minimum area	7.60	mm ²
m	mass of core half	≈ 0.35	g

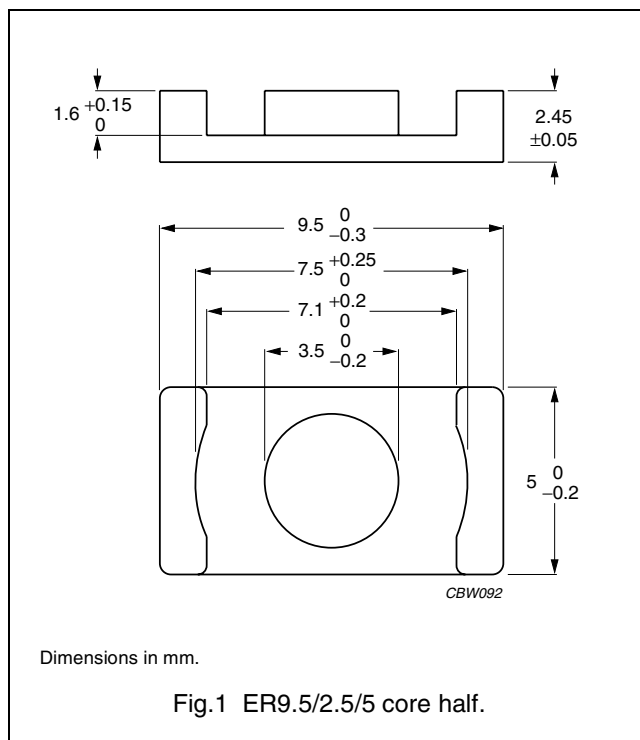

Core sets for general purpose transformers and power applications

Clamping force for A_L measurements, 10 ± 5 N.

GRADE	A_L (nH)	μ_e	AIR GAP (μm)	TYPE NUMBER
3C92 des	750 ±25%	≈ 1000	≈ 0	ER9.5/2.5/5-3C92-S
3C93 des	850 ±25%	≈ 1130	≈ 0	ER9.5/2.5/5-3C93-S
3C94	63 ±3%	≈ 84	≈ 200	ER9.5/2.5/5-3C94-A63-S
	100 ±5%	≈ 133	≈ 120	ER9.5/2.5/5-3C94-A100-S
	160 ±8%	≈ 213	≈ 70	ER9.5/2.5/5-3C94-A160-S
	1000 ±25%	≈ 1330	≈ 0	ER9.5/2.5/5-3C94-S
3C95 des	1150 ±25%	≈ 1540	≈ 0	ER9.5/2.5/5-3C95-S
3C96 des	900 ±25%	≈ 1200	≈ 0	ER9.5/2.5/5-3C96-S
3F3	63 ±3%	≈ 84	≈ 200	ER9.5/2.5/5-3F3-A63-S
	100 ±5%	≈ 133	≈ 120	ER9.5/2.5/5-3F3-A100-S
	160 ±8%	≈ 213	≈ 70	ER9.5/2.5/5-3F3-A160-S
	850 ±25%	≈ 1130	≈ 0	ER9.5/2.5/5-3F3-S
3F35 des	700 ±25%	≈ 930	≈ 0	ER9.5/2.5/5-3F35-S
3F4 des	40 ±3%	≈ 53	≈ 340	ER9.5/2.5/5-3F4-A40-S
	63 ±5%	≈ 84	≈ 190	ER9.5/2.5/5-3F4-A63-S
	100 ±5%	≈ 133	≈ 100	ER9.5/2.5/5-3F4-A100-S
	525 ±25%	≈ 700	≈ 0	ER9.5/2.5/5-3F4-S
3F45 prot	525 ±25%	≈ 700	≈ 0	ER9.5/2.5/5-3F45-S

Planar ER cores and accessories

ER9.5/2.5/5

Core sets of high permeability gradesClamping force for A_L measurements, 10 ± 5 N.

GRADE	A_L (nH)	μ_e	AIR GAP (μm)	TYPE NUMBER
3E5	3600 +40/-30%	≈ 4800	≈ 0	ER9.5/2.5/5-3E5-S
3E6	4800 +40/-30%	≈ 6400	≈ 0	ER9.5/2.5/5-3E6-S

Properties of core sets under power conditions

GRADE	B (mT) at	CORE LOSS (W) at				
	H = 250 A/m; f = 25 kHz; T = 100 °C	f = 100 kHz; B = 100 mT; T = 100 °C	f = 100 kHz; B = 200 mT; T = 25 °C	f = 100 kHz; B = 200 mT; T = 100 °C	f = 400 kHz; B = 50 mT; T = 100 °C	f = 500 kHz; B = 50 mT; T = 100 °C
3C92	≥ 370	≤ 0.011	–	≤ 0.072	–	–
3C93	≥ 320	$\leq 0.011^{(1)}$	–	$\leq 0.072^{(1)}$	–	–
3C94	≥ 320	≤ 0.011	–	≤ 0.072	–	–
3C95	≥ 320	–	≤ 0.07	≤ 0.07	–	–
3C96	≥ 340	≤ 0.0085	–	≤ 0.058	≤ 0.018	≤ 0.045
3F3	≥ 300	≤ 0.015	–	–	≤ 0.025	–
3F35	≥ 300	–	–	–	≤ 0.011	≤ 0.016
3F4	≥ 250	–	–	–	–	–

1. Measured at 140 °C.

Properties of core sets under power conditions (continued)

GRADE	B (mT) at	CORE LOSS (W) at			
	H = 250 A/m; f = 25 kHz; T = 100 °C	f = 500 kHz; B = 100 mT; T = 100 °C	f = 1 MHz; B = 30 mT; T = 100 °C	f = 1 MHz; B = 50 mT; T = 100 °C	f = 3 MHz; B = 10 mT; T = 100 °C
3F35	≥ 300	≤ 0.13	–	–	–
3F4	≥ 250	–	≤ 0.036	–	≤ 0.056
3F45	≥ 250	–	≤ 0.027	≤ 0.1	≤ 0.048

COIL FORMERS

General data

PARAMETER	SPECIFICATION
Coil former material	liquid crystal polymer (LCP), glass reinforced, flame retardant in accordance with "UL 94V-0"; UL file number E54705(M)
Pin material	copper-tin alloy (CuSn), tin (Sn) plated
Maximum operating temperature	155 °C, "IEC 60085", class F
Resistance to soldering heat	"IEC 60068-2-20", Part 2, Test Tb, method 1B: 350 °C, 3.5 s
Solderability	"IEC 60068-2-20", Part 2, Test Ta, method 1: 235 °C, 2 s

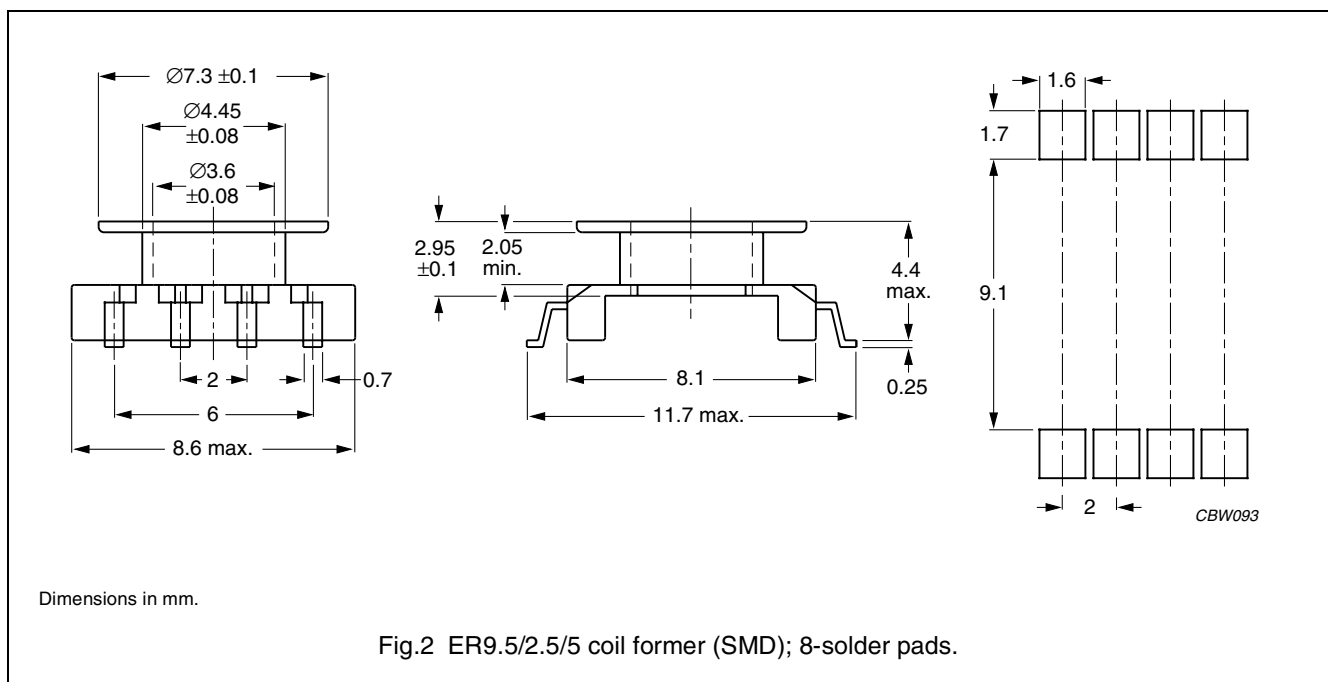

Winding data and area product for ER9.5/2.5/5 coil former (SMD) with 8 solder pads

NUMBER OF SECTIONS	WINDING AREA (mm ²)	MINIMUM WINDING WIDTH (mm)	AVERAGE LENGTH OF TURN (mm)	AREA PRODUCT Ae x Aw (mm ⁴)	TYPE NUMBER
1	2.8	2.05	18.4	23.7	CPVS-ER9.5-1S-8P-Z

MOUNTING PARTS

General data and ordering information

ITEM	REMARKS	FIGURE	TYPE NUMBER
Clamp	stainless steel (CrNi); clamping force \approx 20 N	3	CLM-ER9.5

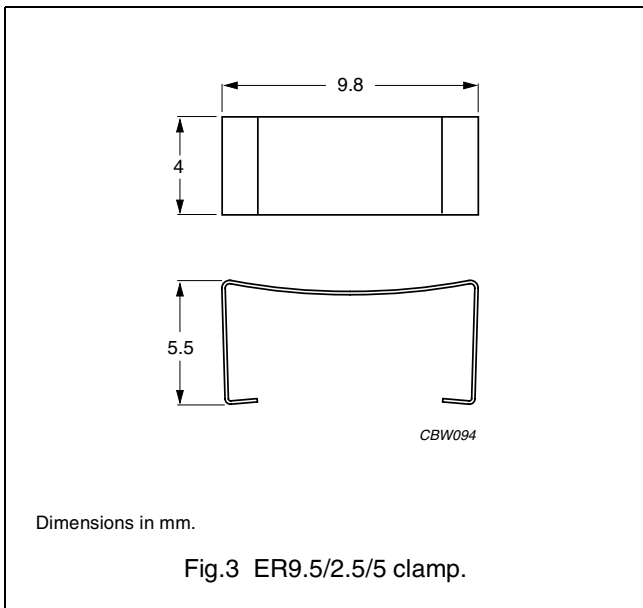



DATA SHEET STATUS DEFINITIONS

DATA SHEET STATUS	PRODUCT STATUS	DEFINITIONS
Preliminary specification	Development	This data sheet contains preliminary data. Ferroxcube reserves the right to make changes at any time without notice in order to improve design and supply the best possible product.
Product specification	Production	This data sheet contains final specifications. Ferroxcube reserves the right to make changes at any time without notice in order to improve design and supply the best possible product.

DISCLAIMER

Life support applications — These products are not designed for use in life support appliances, devices, or systems where malfunction of these products can reasonably be expected to result in personal injury. Ferroxcube customers using or selling these products for use in such applications do so at their own risk and agree to fully indemnify Ferroxcube for any damages resulting from such application.

PRODUCT STATUS DEFINITIONS

STATUS	INDICATION	DEFINITION
Prototype		These are products that have been made as development samples for the purposes of technical evaluation only. The data for these types is provisional and is subject to change.
Design-in		These products are recommended for new designs.
Preferred		These products are recommended for use in current designs and are available via our sales channels.
Support		These products are not recommended for new designs and may not be available through all of our sales channels. Customers are advised to check for availability.