

**8-bit Constant Current LED Sink Driver****Features**

- I 8 constant-current output channels
- I Constant output current invariant to load voltage change
- I Excellent output current accuracy:
between channels: $< \pm 3\%$ (max.), and
between ICs: $< \pm 6\%$ (max.)
- I Output current adjusted through an external resistor
- I Constant output current range: 5 -120 mA
- I Fast response of output current,
 \overline{OE} (min.): 200 ns @ $I_{out} < 60\text{mA}$
 \overline{OE} (min.): 400 ns @ $I_{out} = 60\sim 100\text{mA}$
- I 25MHz clock frequency
- I Schmitt trigger input
- I 5V supply voltage

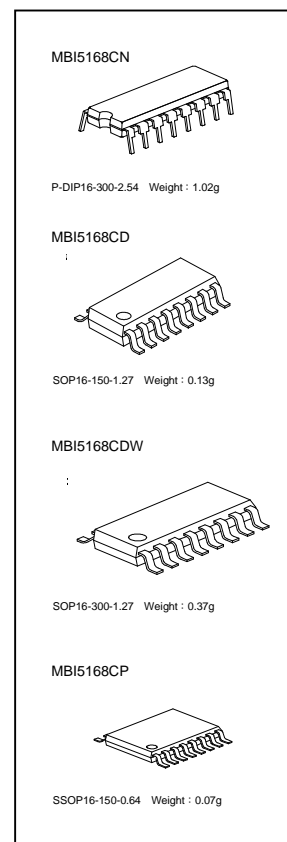

Current Accuracy		Conditions
Between Channels	Between ICs	
$< \pm 3\%$	$< \pm 6\%$	$I_{OUT} = 10 \sim 100 \text{ mA}$, $V_{DS} = 0.8\text{V}$

Product Description

MBI5168 is designed for LED display applications. As an enhancement of its predecessor, MBI5001, MBI5168 exploits PrecisionDrive™ technology to enhance its output characteristics. MBI5168 contains a serial buffer and data latches, which convert serial input data into parallel output format. At MBI5168 output stage, eight regulated current ports are designed to provide uniform and constant current sinks for driving LEDs within a large range of V_f variations.

MBI5168 provides users with great flexibility and device performance while using MBI5168 in their system design for LED display applications, e.g. LED panels. Users may adjust the output current from 5 mA to 120 mA through an external resistor R_{ext} , which gives users flexibility in controlling the light intensity of LEDs. MBI5168 guarantees to endure maximum 17V at the output ports. The high clock frequency up to 25 MHz also satisfies the system requirements of high volume data transmission.

Terminal Description

Pin No.	Pin Name	Function
1	GND	Ground terminal for control logic and current sinks
2	SDI	Serial-data input to the shift register
3	CLK	Clock input terminal for data shift on rising edge
4	LE	Data strobe input terminal Serial data is transferred to the respective latch when LE is high. The data is latched when LE goes low.
5-12	$\overline{\text{OUT0}} \sim \overline{\text{OUT7}}$	Constant current output terminals
13	$\overline{\text{OE}}$	Output enable terminal When (active) low, the output drivers are enabled; when high, all output drivers are turned OFF (blanked).
14	SDO	Serial-data output to the following SDI of next driver IC
15	R-EXT	Input terminal used to connect an external resistor for setting up output current for all output channels
16	VDD	5V supply voltage terminal

Pin Description

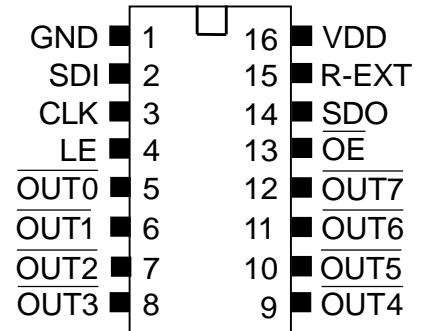

Block Diagram

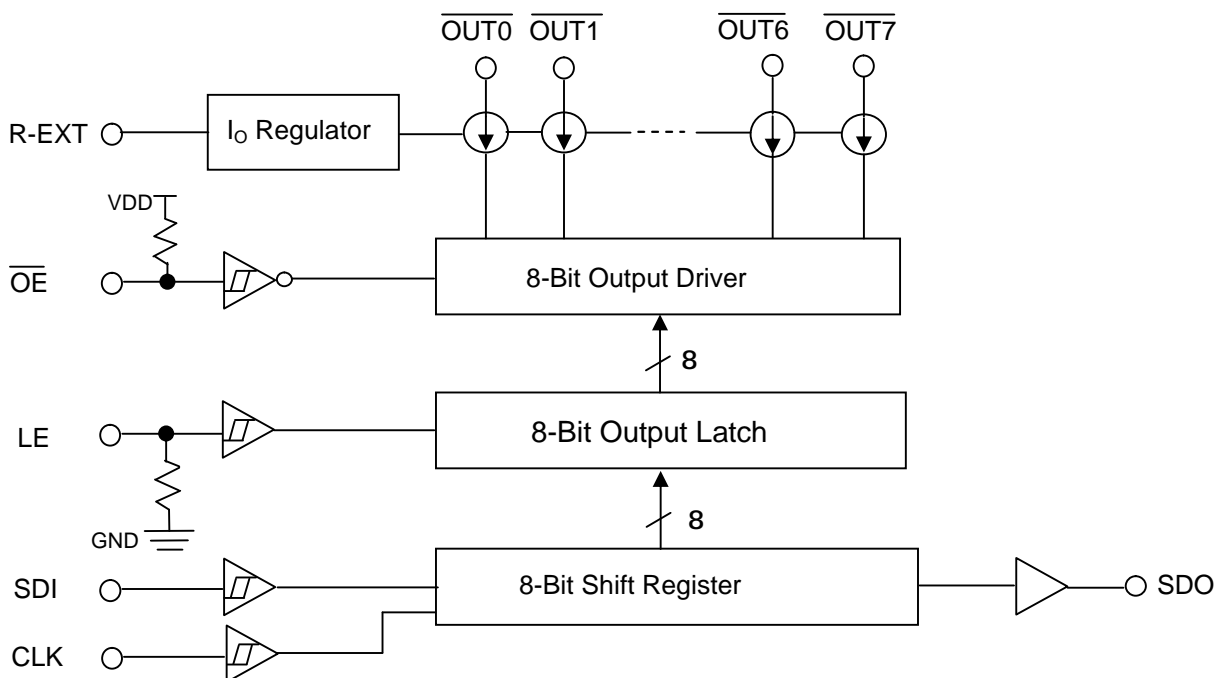

Equivalent Circuits of Inputs and Outputs

\overline{OE} terminal

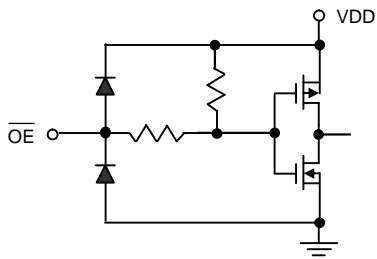

LE terminal

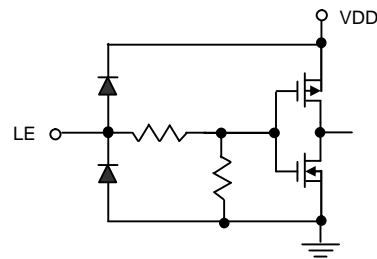

CLK, SDI terminal

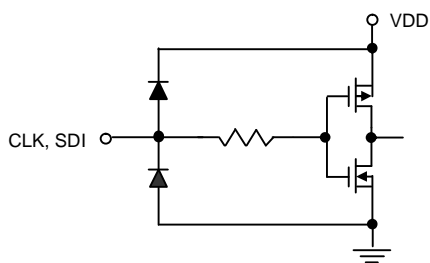



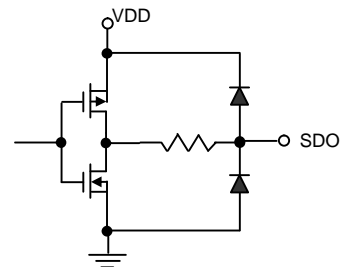

SDO terminal

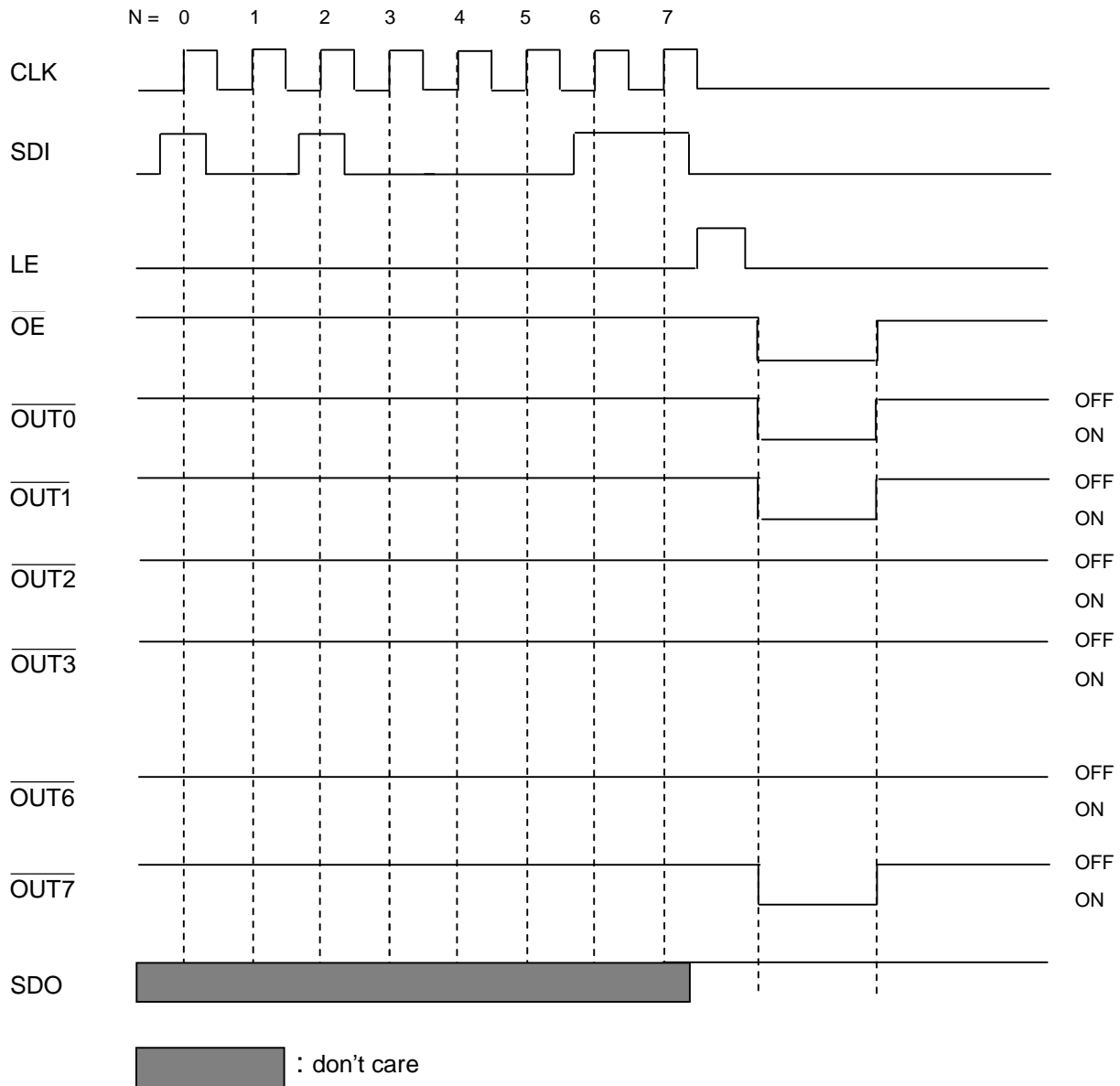

Timing Diagram



Truth Table

CLK	LE	OE	SDI	OUT0 ... OUT5 ... OUT7	SDO
	H	L	D_n	$\overline{D_n} \dots \overline{D_{n-5}} \dots \overline{D_{n-7}}$	D_{n-7}
	L	L	D_{n+1}	No Change	D_{n-6}
	H	L	D_{n+2}	$\overline{D_{n+2}} \dots \overline{D_{n-3}} \dots \overline{D_{n-5}}$	D_{n-5}
	X	L	D_{n+3}	$\overline{D_{n+2}} \dots \overline{D_{n-3}} \dots \overline{D_{n-5}}$	D_{n-5}
	X	H	D_{n+3}	Off	D_{n-5}

Maximum Ratings

Characteristic		Symbol	Rating	Unit
Supply Voltage		V_{DD}	0 ~ 7.0	V
Input Voltage		V_{IN}	-0.4 ~ $V_{DD}+0.4$	V
Output Current		I_{OUT}	+120	mA
Output Voltage		V_{DS}	-0.5 ~ +20.0	V
Clock Frequency		F_{CLK}	25	MHz
GND Terminal Current		I_{GND}	1000	mA
Power Dissipation (On PCB, $T_a=25^\circ\text{C}$)	CN – type	P_D	2.03	W
	CD – type		1.46	
	CDW – type		2.03	
	CP – type		1.32	
Thermal Resistance (On PCB, $T_a=25^\circ\text{C}$)	CN – type	$R_{th(j-a)}$	61.65	$^\circ\text{C/W}$
	CD – type		85.82	
	CDW – type		61.63	
	CP – type		94.91	
Operating Temperature		T_{opr}	-40 ~ +85	$^\circ\text{C}$
Storage Temperature		T_{stg}	-55 ~ +150	$^\circ\text{C}$

Electrical Characteristics

Characteristic		Symbol	Condition		Min.	Typ.	Max.	Unit
Supply Voltage		V_{DD}	-		4.5	5.0	5.5	V
Output Voltage		V_{DS}	$\overline{OUT0} \sim \overline{OUT7}$		-	-	17.0	V
Output Current		I_{OUT}	Test Circuit for Electrical Characteristics		5	-	120	mA
		I_{OH}	SDO		-	-	-1.0	mA
		I_{OL}	SDO		-	-	1.0	mA
Input Voltage	“H” level	V_{IH}	$T_a = -40 \sim 85^\circ C$		$0.8V_{DD}$	-	V_{DD}	V
	“L” level	V_{IL}	$T_a = -40 \sim 85^\circ C$		GND	-	$0.3V_{DD}$	V
Output Leakage Current			$V_{OH} = 17.0V$ and channel off		-	-	0.5	μA
Output Voltage	SDO	V_{OL}	$I_{OL} = +1.0mA$		-	-	0.4	V
		V_{OH}	$I_{OH} = -1.0mA$		4.6	-	-	V
Output Current 1		I_{OUT1}	$V_{DS} = 0.5V$	$R_{ext} = 744 \Omega$	-	25.26	-	mA
Current Skew (between channels)		dI_{OUT1}	$I_{OUT} = 25.26mA$ $V_{DS} \geq 0.5V$	$R_{ext} = 744 \Omega$	-	± 1	± 3	%
Output Current 2		I_{OUT2}	$V_{DS} = 0.6V$	$R_{ext} = 372 \Omega$	-	50.52	-	mA
Current Skew (between channels)		dI_{OUT2}	$I_{OUT} = 50.52mA$ $V_{DS} \geq 0.6V$	$R_{ext} = 372 \Omega$	-	± 1	± 3	%
Output Current 3		I_{OUT3}	$V_{DS} = 0.8V$	$R_{ext} = 186 \Omega$	-	101.0	-	mA
Current Skew (between channels)		dI_{OUT3}	$I_{OUT} = 101.0mA$ $V_{DS} \geq 0.8V$	$R_{ext} = 186 \Omega$	-	± 1	± 3	%
Output Current vs. Output Voltage Regulation		$\%/dV_{DS}$	V_{DS} within 1.0V and 3.0V		-	± 0.1	-	% / V
Output Current vs. Supply Voltage Regulation		$\%/dV_{DD}$	V_{DD} within 4.5V and 5.5V		-	± 1	-	% / V
Pull-up Resistor		$R_{IN(up)}$	\overline{OE}		250	500	800	K Ω
Pull-down Resistor		$R_{IN(down)}$	LE		250	500	800	K Ω
Supply Current	“OFF”	$I_{DD(off) 1}$	$R_{ext} = \text{Open}, \overline{OUT0} \sim \overline{OUT7} = \text{Off}$		-	3.25	-	mA
		$I_{DD(off) 2}$	$R_{ext} = 744 \Omega, \overline{OUT0} \sim \overline{OUT7} = \text{Off}$		-	5	-	
		$I_{DD(off) 3}$	$R_{ext} = 372 \Omega, \overline{OUT0} \sim \overline{OUT7} = \text{Off}$		-	6.8	-	
		$I_{DD(off) 4}$	$R_{ext} = 186 \Omega, \overline{OUT0} \sim \overline{OUT7} = \text{Off}$		-	10.5	-	
	“ON”	$I_{DD(on) 1}$	$R_{ext} = 744 \Omega, \overline{OUT0} \sim \overline{OUT7} = \text{On}$		-	5	-	
		$I_{DD(on) 2}$	$R_{ext} = 372 \Omega, \overline{OUT0} \sim \overline{OUT7} = \text{On}$		-	6.8	-	
		$I_{DD(on) 3}$	$R_{ext} = 186 \Omega, \overline{OUT0} \sim \overline{OUT7} = \text{On}$		-	10.5	-	

Test Circuit for Electrical Characteristics

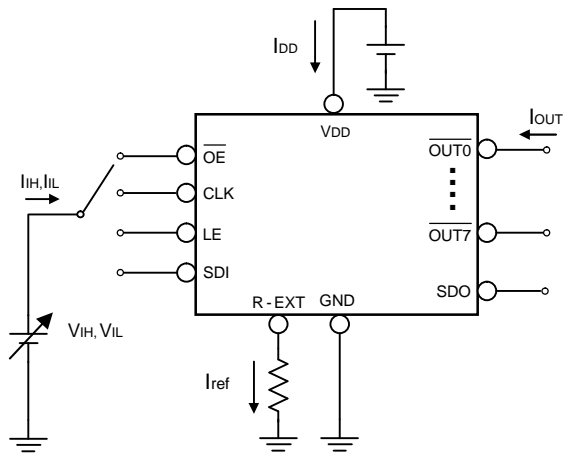

Switching Characteristics

Characteristic		Symbol	Condition	Min.	Typ.	Max.	Unit
Propagation Delay Time ("L" to "H")	CLK - $\overline{\text{OUTn}}$	t_{pLH1}	Test Circuit for Switching Characteristics $V_{DD} = 5.0\text{ V}$ $V_{DS} = 0.8\text{ V}$ $V_{IH} = V_{DD}$ $V_{IL} = \text{GND}$ $R_{ext} = 372\ \Omega$ $V_L = 4.0\text{ V}$ $R_L = 64\ \Omega$ $C_L = 10\text{ pF}$	-	50	100	ns
	LE - $\overline{\text{OUTn}}$	t_{pLH2}		-	50	100	ns
	$\overline{\text{OE}}$ - $\overline{\text{OUTn}}$	t_{pLH3}		-	20	100	ns
	CLK - SDO	t_{pLH}		15	20	-	ns
Propagation Delay Time ("H" to "L")	CLK - $\overline{\text{OUTn}}$	t_{pHL1}		-	100	150	ns
	LE - $\overline{\text{OUTn}}$	t_{pHL2}		-	100	150	ns
	$\overline{\text{OE}}$ - $\overline{\text{OUTn}}$	t_{pHL3}		-	50	150	ns
	CLK - SDO	t_{pHL}		15	20	-	ns
Pulse Width	CLK	$t_w(\text{CLK})$		20	-	-	ns
	LE	$t_w(\text{L})$		20	-	-	ns
	$\overline{\text{OE}}$ (@ $I_{out} < 60\text{mA}$)	$t_w(\text{OE})$		200	-	-	ns
Hold Time for LE		$t_h(\text{L})$		10	-	-	ns
Setup Time for LE		$t_{su}(\text{L})$		5	-	-	ns
Hold Time for SDI		$t_h(\text{D})$		10	-	-	ns
Setup Time for SDI		$t_{su}(\text{D})$		5	-	-	ns
Maximum CLK Rise Time		t_r^{**}		-	-	500	ns
Maximum CLK Fall Time		t_f^{**}	-	-	500	ns	
Output Rise Time of Vout (turn off)		t_{or}	-	40	120	ns	
Output Fall Time of Vout (turn on)		t_{of}	-	70	200	ns	
Clock Frequency		F_{CLK}	Cascade Operation	-	-	25.0	MHz

**If the devices are connected in cascade and t_r or t_f is large, it may be critical to achieve the timing required for data transfer between two cascaded devices.

Test Circuit for Switching Characteristics

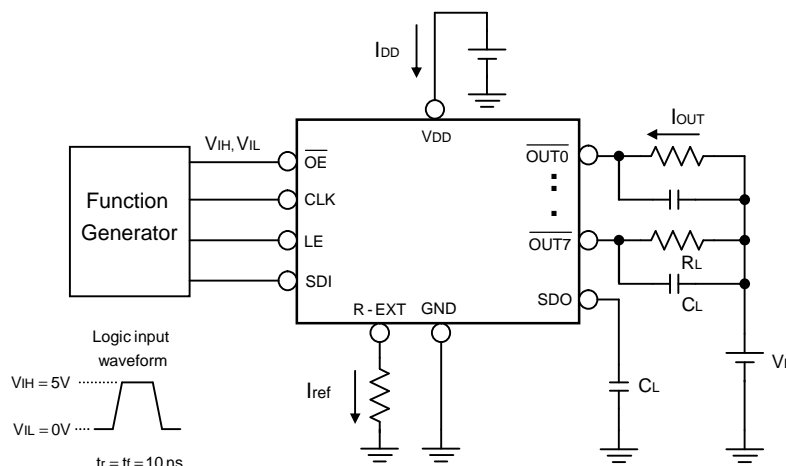

Timing Waveform

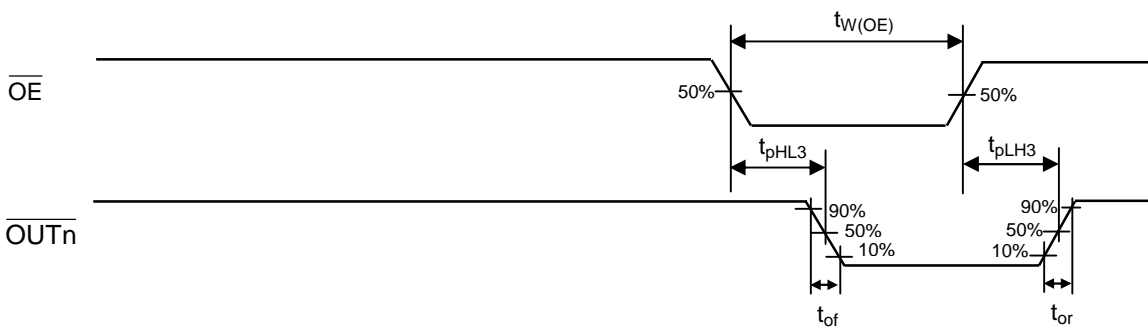
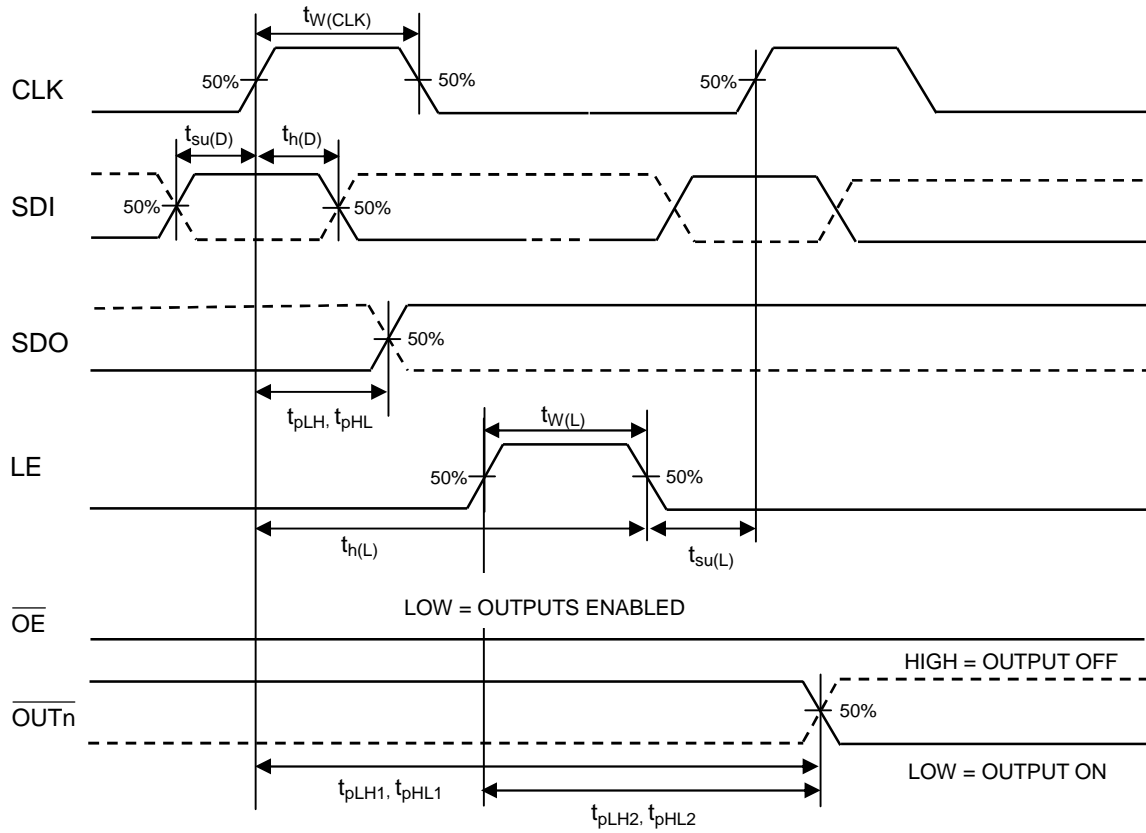

Application Information

Constant Current

In LED display application, MBI5168 provides nearly no variations in current from channel to channel and from IC to IC. This can be achieved by:

- 1) While $I_{OUT} \leq 100\text{mA}$, the maximum current variation between channels is less than $\pm 3\%$, and that between ICs is less than $\pm 6\%$.
- 2) In addition, the characteristics curve of output stage in the saturation region is flat and users can refer to the figure as shown below. Thus, the output current can be kept constant regardless of the variations of LED forward voltages (V_f).

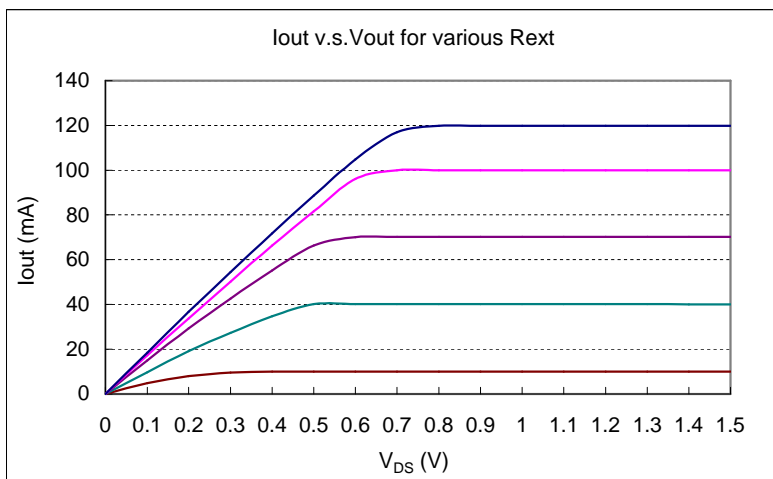

Adjusting Output Current

The output current of each channel (I_{OUT}) is set by an external resistor, R_{ext} . The relationship between I_{out} and R_{ext} is shown in the following figure.

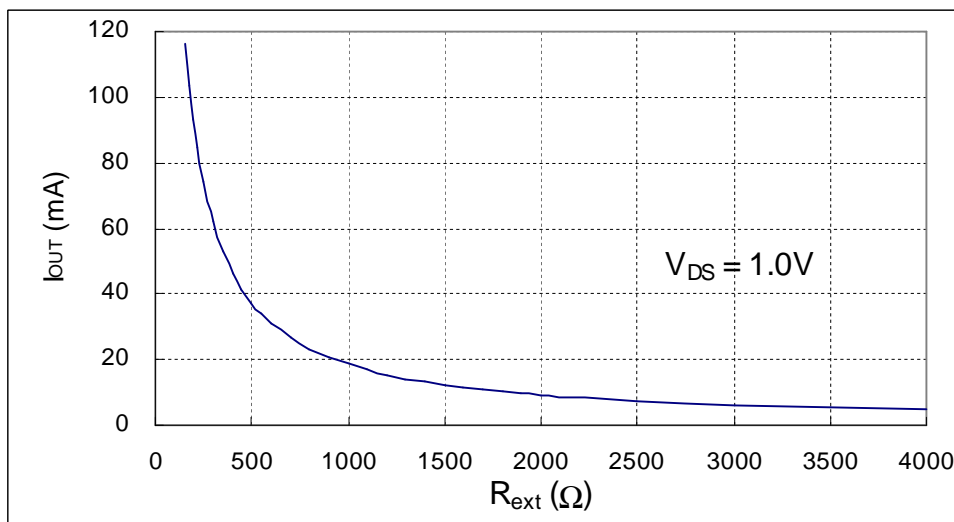

Resistance of the external resistor, R_{ext} , in Ω

Also, the output current can be calculated from the equation:

$$V_{R-EXT} = 1.253\text{Volt}$$

$$I_{ref} = V_{R-EXT} / R_{ext} \quad \text{if another end of the external resistor } R_{ext} \text{ is connected to ground.}$$

$$I_{OUT} = I_{ref} \times 15 = 1.253\text{Volt} / R_{ext} \times 15.$$

where R_{ext} is the resistance of the external resistor connected to R-EXT terminal and V_{R-EXT} is the voltage of R-EXT terminal. The magnitude of current (as a function of R_{ext}) is around 50.52mA at 372 Ω and 25.26mA at 744 Ω .

Package Power Dissipation (P_D)

The maximum allowable package power dissipation is determined as $P_D(max) = (T_j - T_a) / R_{th(j-a)}$. When 8 output channels are turned on simultaneously, the actual package power dissipation is $P_D(act) = (I_{DD} \times V_{DD}) + (I_{OUT} \times Duty \times V_{DS} \times 8)$. Therefore, to keep $P_D(act) \leq P_D(max)$, the allowable maximum output current as a function of duty cycle is:

$$I_{OUT} = \{ [(T_j - T_a) / R_{th(j-a)}] - (I_{DD} \times V_{DD}) \} / V_{DS} / Duty / 8,$$

where $T_j = 150^\circ C$.

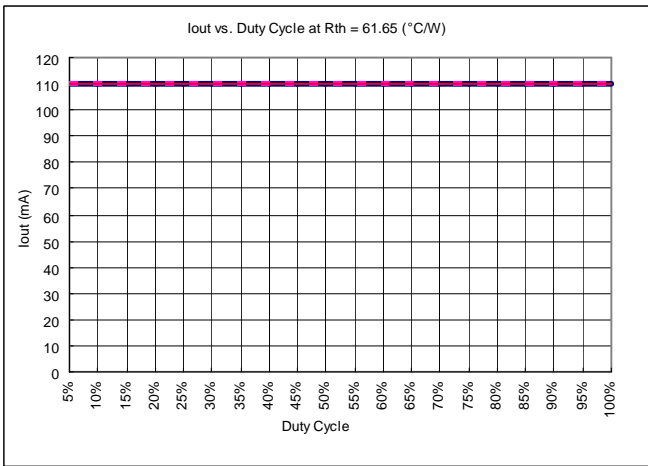

CN Device Type

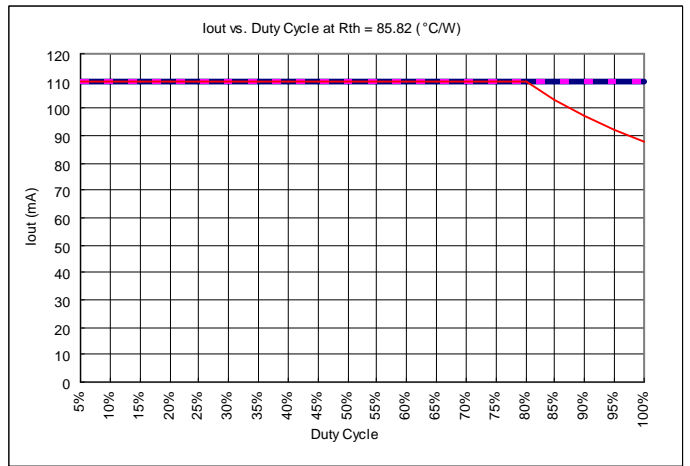

CD Device Type

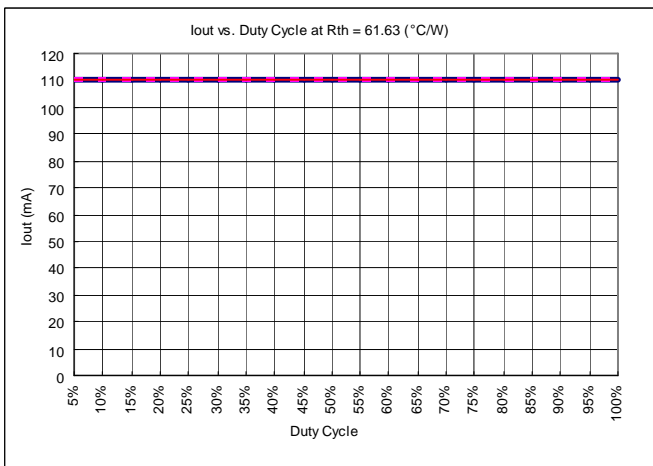

CDW Device Type

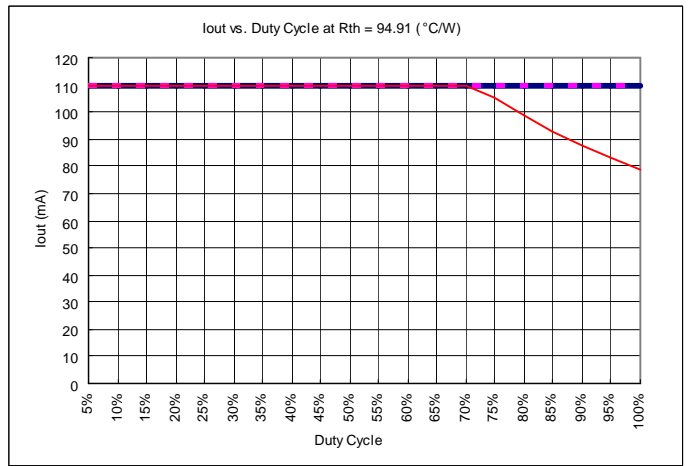

CP Device Type

Condition : $V_{DS} = 1.0V$, 8 output channels active ,
 T_a is listed in the below legends.

Device Type	$R_{th(j-a)}$ (°C/W)	Note
CN	61.65	
CD	85.82	
CDW	61.63	
CP	94.91	

The maximum power dissipation, $P_D(max) = (T_j - T_a) / R_{th(j-a)}$, decreases as the ambient temperature increases.

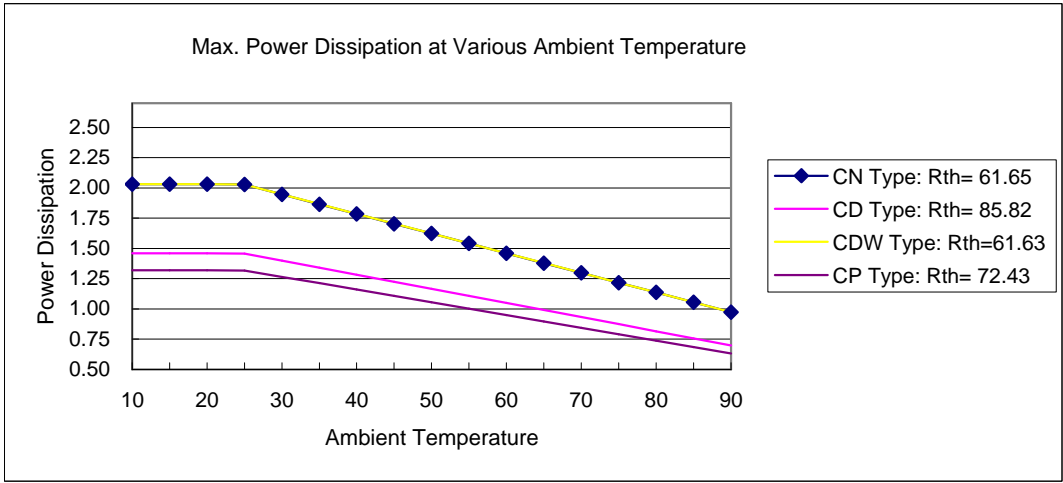

Load Supply Voltage (V_{LED})

MBI5168 are designed to operate with V_{DS} ranging from 0.4V to 1.0V considering the package power dissipating limits. V_{DS} may be so high as to make P_{D(act)} > P_{D(max)} under higher V_{LED}, for instance, than 5V, where V_{DS} = V_{LED} - V_f and V_{LED} is the load supply voltage. In this case, it is recommended to use the lowest possible supply voltage or to set an external voltage reducer, V_{DROP}.

A voltage reducer lets V_{DS} = (V_{LED} - V_f) - V_{DROP}.

Resistors or Zener diode can be used in the applications as shown in the following figures.

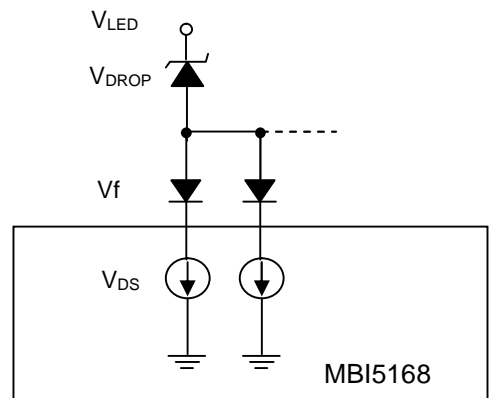
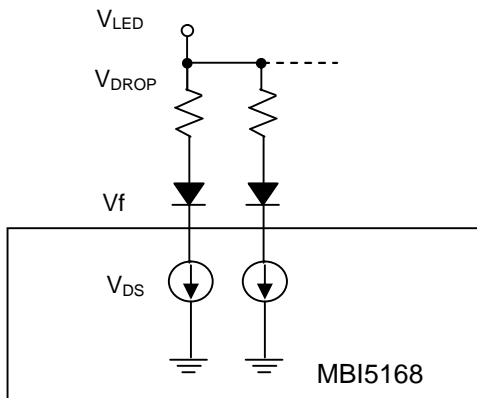

Outline Drawings

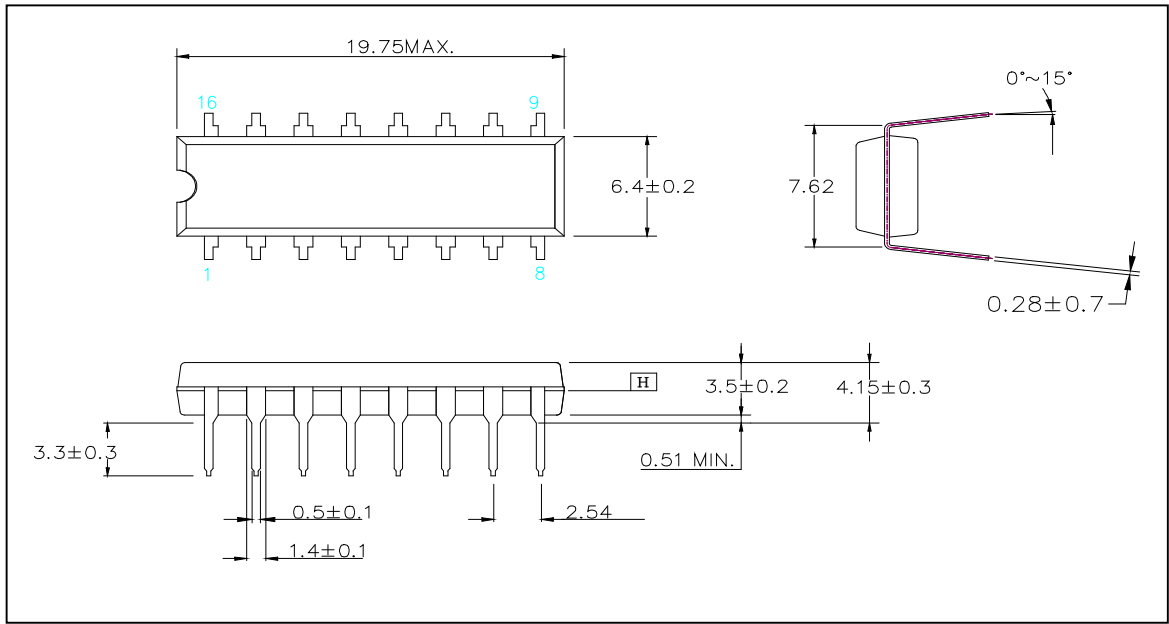

MBI5168CN Outline Drawing

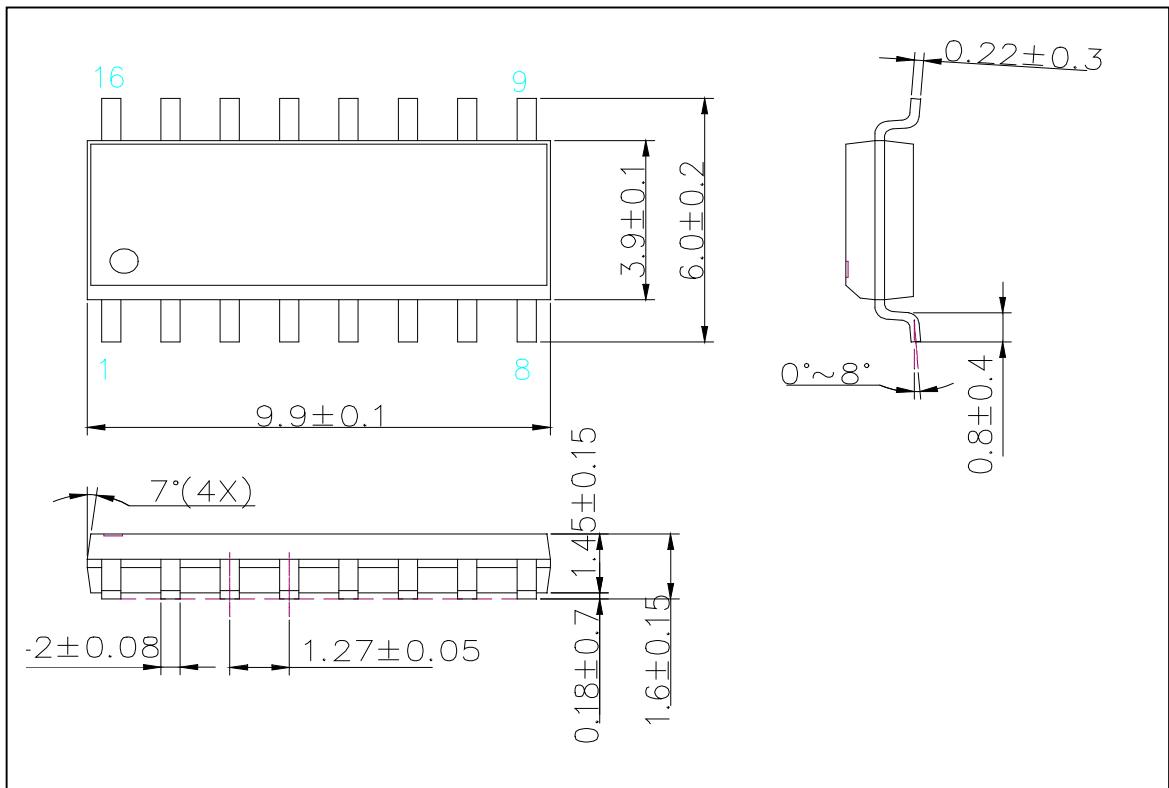

MBI5168CD Outline Drawing

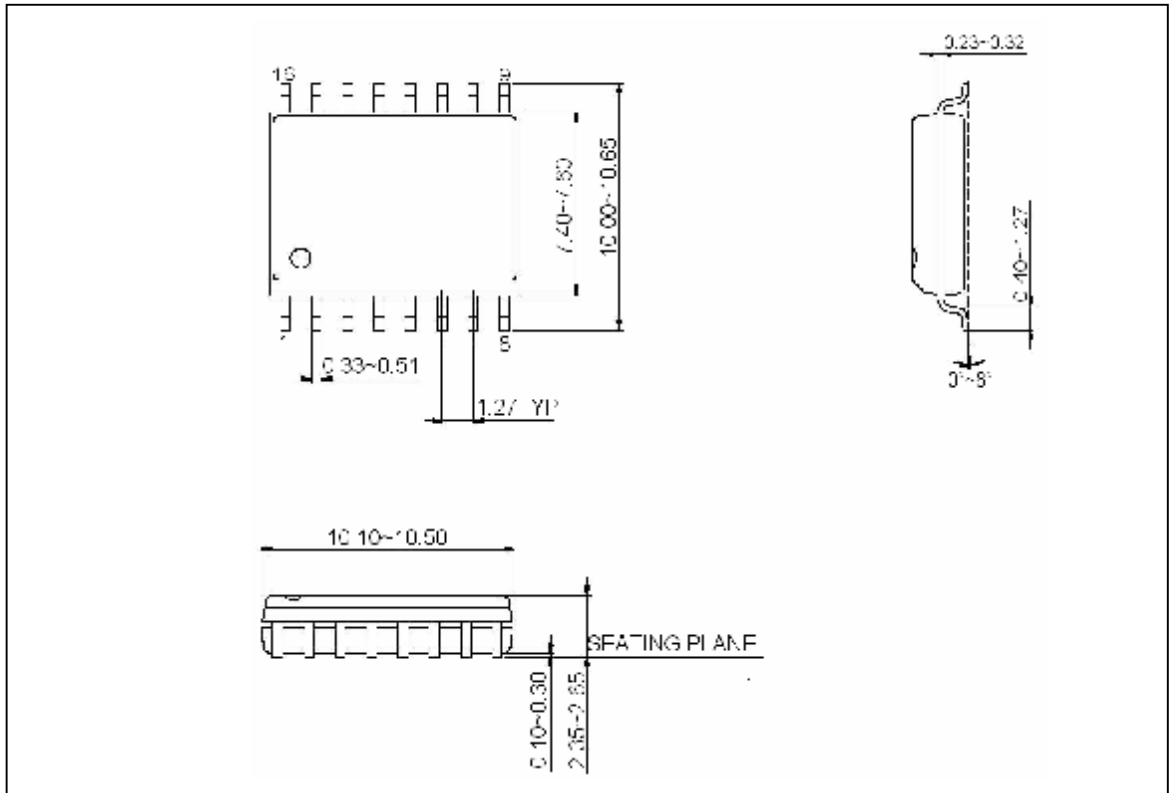

MBI5168CDW Outline Drawing

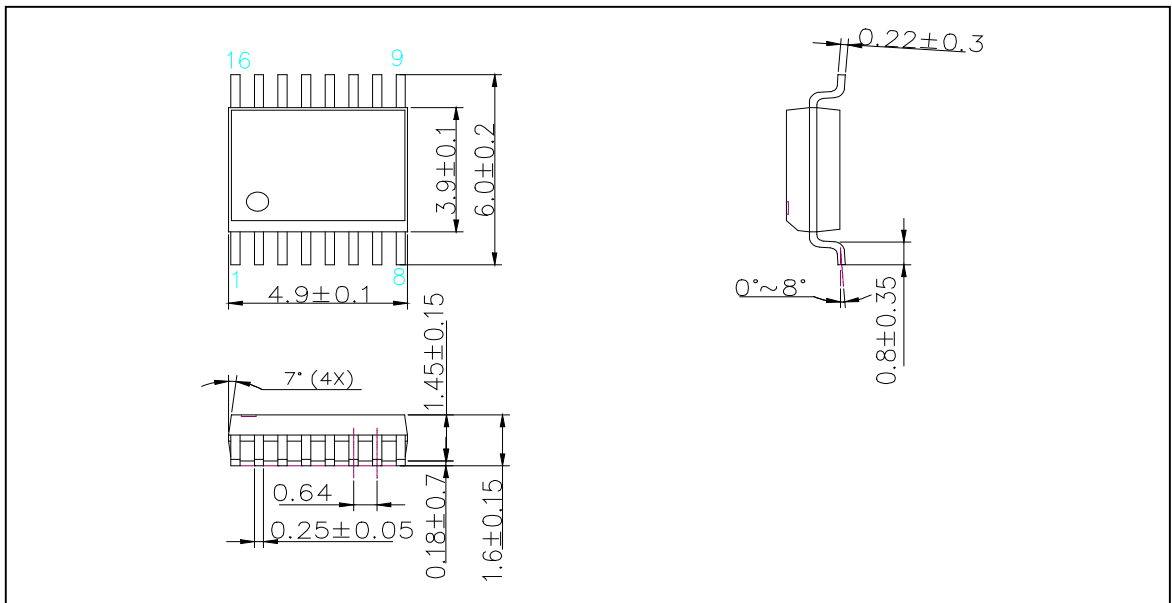

MBI5168CP Outline Drawing

MBI5168 Package Information

Device Type	Package Type	Weight(g)
CN	P-DIP16-300-2.54	1.02
CD	SOP16-150-1.27	0.13
CDW	SOP16-300-1.27	0.37
CP	SSOP16-150-0.64	0.07

Note: The unit for the outline drawing is mm.