

### Primax

Synonymous with function and performance, enter the Primax, the new era of high intensity illumination in LED. With its high flux output and high luminous intensity, Primax transcends today LED lightings technology and how we perceive it. The small package outline and high intensity make it an ideal choice for backlighting, signage, exterior automotive lighting and decorative lighting.



### Features:

- > Super high brightness surface mount LED
- > 120° viewing angle.
- > Compact package outline (LxW) of 3.7 x 3.5 mm.
- > Ultra low height profile - 0.8mm.
- > Low thermal resistance.
- > Compatible to IR reflow soldering.
- > Environmental friendly; RoHS compliance.
- > Compliance to automotive standard; AEC-Q101.
- > Passed Corrosion Resistant Test. *Appx. 4.1*

### Applications:

- > Automotive Interior Lighting  
(Dome lamp, map lighting, and trunk lighting)
- > Industrial Illumination.
- > White Goods Lighting.

### Optical Characteristics at Tj=25°C

Part Ordering Number	Color	Viewing Angle°	Luminous Flux @ 100mA (lm) <i>Appx. 1.2</i>		
			Min.	Typ.	Max.
PQW-SSG-QR3-1	White	120	30.6	39.8	51.7

Notes:

1. High color rendering index (CRI). Minimum CRI of 80.

### Electrical Characteristics at Tj=25°C

Part Number	Vf @ If = 100 mA <i>Appx. 3.1</i>			Vr @ Ir = 10uA
	Min. (V)	Typ. (V)	Max. (V)	Min. (V)
PQW-SSG	2.8	3.1	3.4	5

### Absolute Maximum Ratings

	Maximum Value	Unit
DC forward current	180	mA
Peak pulse current (tp ≤ 10ms, Duty cycle = 0.5)	360	mA
Reverse voltage	5	V
ESD threshold (HBM)	2000	V
LED junction temperature	150	°C
Operating temperature	-40 ... +125	°C
Storage temperature	-40 ... +125	°C
Thermal resistance		
- Real Thermal Resistance		
Junction / ambient, R <sub>th JA real</sub> (Typ = 90K/W)	120	K/W
Junction / solder point, R <sub>th JS real</sub> (Typ = 30K/W)	45	K/W
(Mounting on DOMINANT standard PCB)		

**PQW-SSG, Color Grouping** *Appx. 2.1*

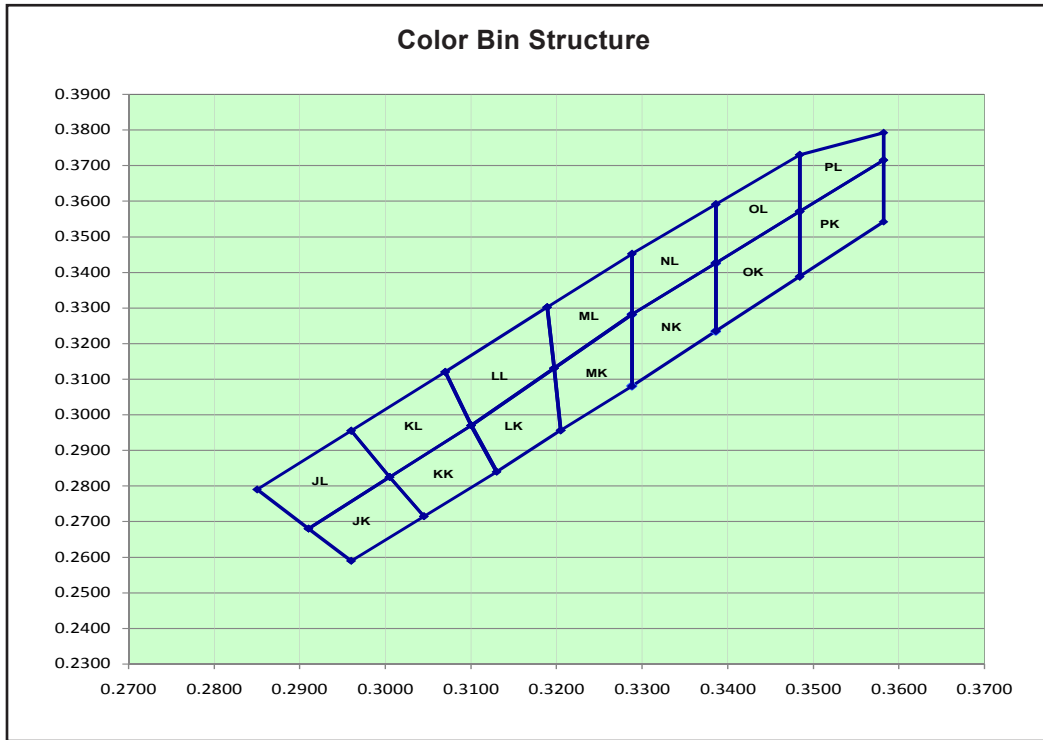

Bin		1	2	3	4
JK	Cx	0.2960	0.2910	0.3005	0.3045
	Cy	0.2590	0.2680	0.2825	0.2715
JL	Cx	0.291	0.2850	0.2960	0.3005
	Cy	0.2680	0.2790	0.2955	0.2825
KK	Cx	0.3045	0.3005	0.3100	0.3130
	Cy	0.2715	0.2825	0.2970	0.2840
KL	Cx	0.3005	0.2960	0.3070	0.3100
	Cy	0.2825	0.2955	0.3120	0.2970
NK	Cx	0.3288	0.3288	0.3386	0.3386
	Cy	0.3081	0.3282	0.3426	0.3235
NL	Cx	0.3288	0.3288	0.3386	0.3386
	Cy	0.3282	0.3453	0.3591	0.3426
OK	Cx	0.3386	0.3386	0.3484	0.3484
	Cy	0.3235	0.3426	0.3571	0.3388
OL	Cx	0.3386	0.3386	0.3484	0.3484
	Cy	0.3426	0.3591	0.3730	0.3571
LK	Cx	0.3100	0.3197	0.3205	0.3130
	Cy	0.2970	0.3131	0.2956	0.2840
LL	Cx	0.3070	0.3189	0.3197	0.3100
	Cy	0.3120	0.3302	0.3131	0.2970

Bin		1	2	3	4
MK	Cx	0.3197	0.3288	0.3288	0.3205
	Cy	0.3131	0.3282	0.3081	0.2956
ML	Cx	0.3189	0.3288	0.3288	0.3197
	Cy	0.3302	0.3452	0.3282	0.3131
PK	Cx	0.3484	0.3484	0.3582	0.3582
	Cy	0.3388	0.3571	0.3715	0.3542
PL	Cx	0.3484	0.3484	0.3582	0.3582
	Cy	0.3571	0.3730	0.3792	0.3715

InGaN wavelength is very sensitive to drive current. Operating at lower current is not recommended and may yield unpredictable performance. Current pulsing should be used for dimming purposes.

**Luminous Intensity Group at Tj=25°C**

Brightness Group	Luminous Flux (lm) <i>Appx. 1.2</i>
Q2	30.6 ... 34.8
Q3	34.8 ... 39.8
R2	39.8 ... 45.2
R3	45.2 ... 51.7

**Vf Binning (Optional)**

Vf @ If = 100mA	Forward Voltage (V) <i>Appx. 3.1</i>
V1	2.80 ... 3.00
V2	3.00 ... 3.20
V3	3.20 ... 3.40

Please consult sales and marketing for special part number to incorporate Vf binning.

**Relative Luminous Flux Vs Forward Current**

$\Phi_V/\Phi_V(100\text{mA}) = f(I_F); T_j = 25^\circ\text{C}$

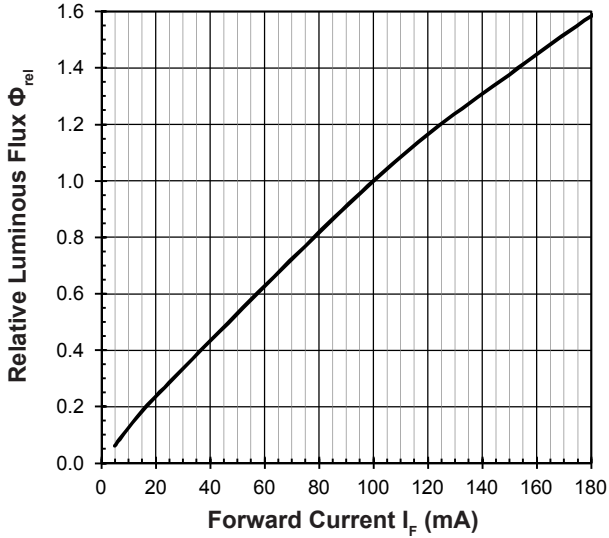

**Forward Current Vs Forward Voltage**

$I_F = f(V_F); T_j = 25^\circ\text{C}$

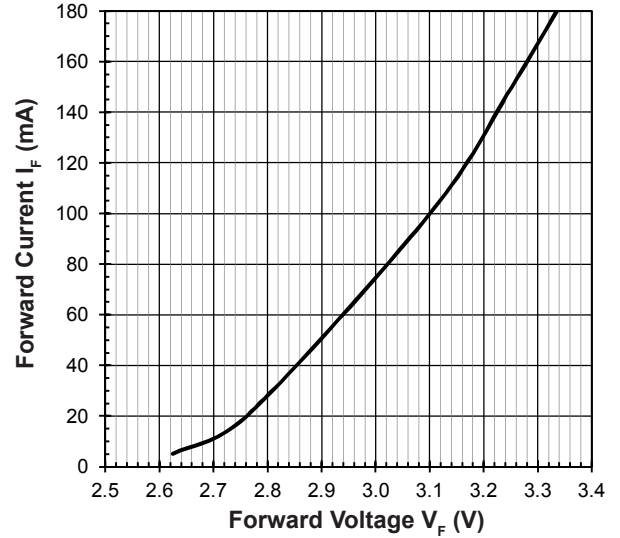

**Maximum Current Vs Temperature**

$I_F = f(T)$

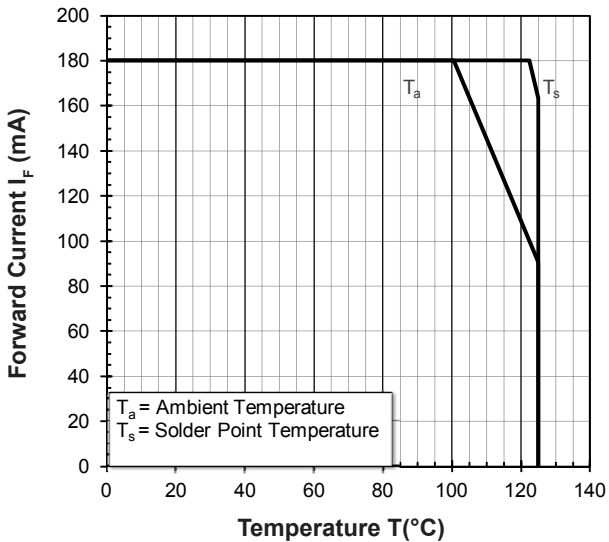

**Relative Spectral Emission**

$\Phi_{rel} = f(\lambda); T_j = 25^\circ\text{C}; I_F = 100\text{mA}$

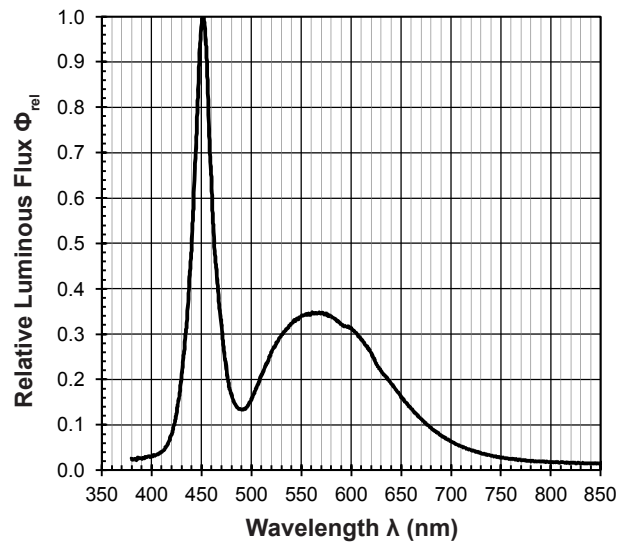

**Chromaticity Coordinate Shift Vs Forward Current**

$\Delta Cx, \Delta Cy = f(I_F); T_j = 25^\circ\text{C}$

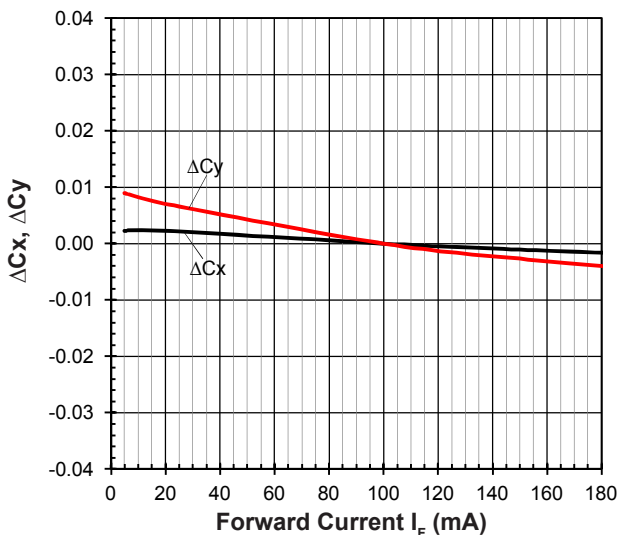

**Allowable Forward Current Vs Duty Ratio**

$(T_j = 25^\circ\text{C}; t_p \leq 10\text{ms})$



**Radiation Pattern**

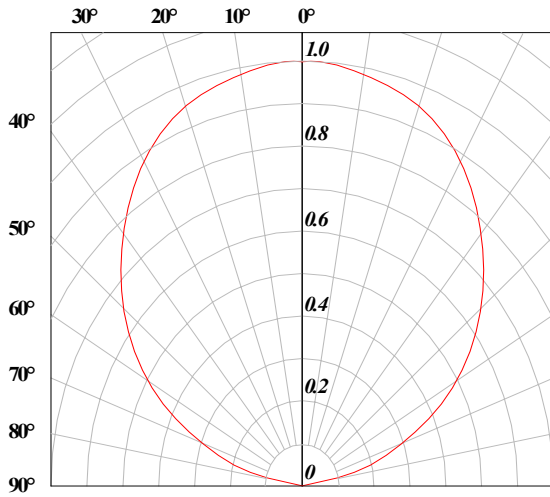

**Relative Forward Voltage Vs Junction Temperature**

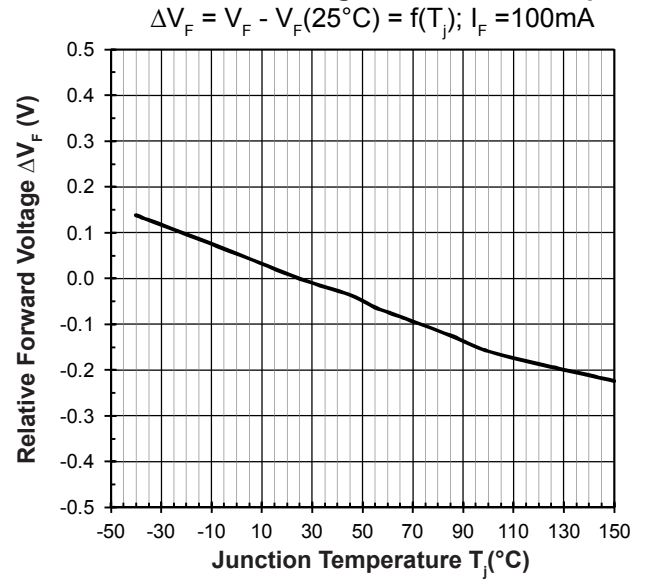

**Relative Luminous Flux Vs Junction Temperature**

$\Phi_V/\Phi_V(25^\circ\text{C}) = f(T_j); I_F = 100\text{mA}$

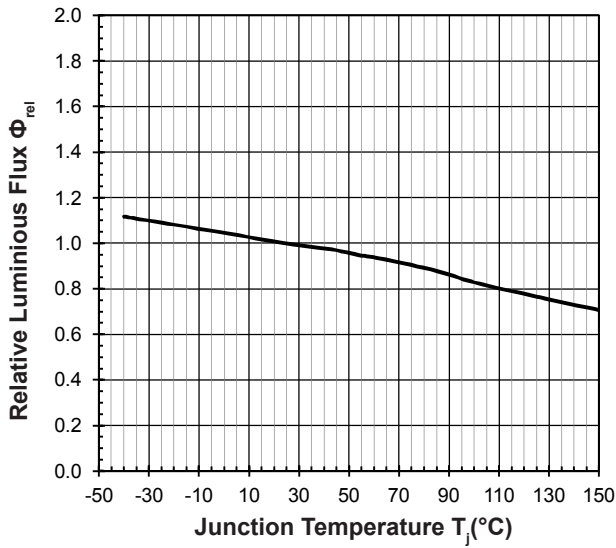

**Chromaticity Coordinate Shift Vs Junction Temperature**

$\Delta C_x, \Delta C_y = f(T_j); I_F = 100\text{mA}$

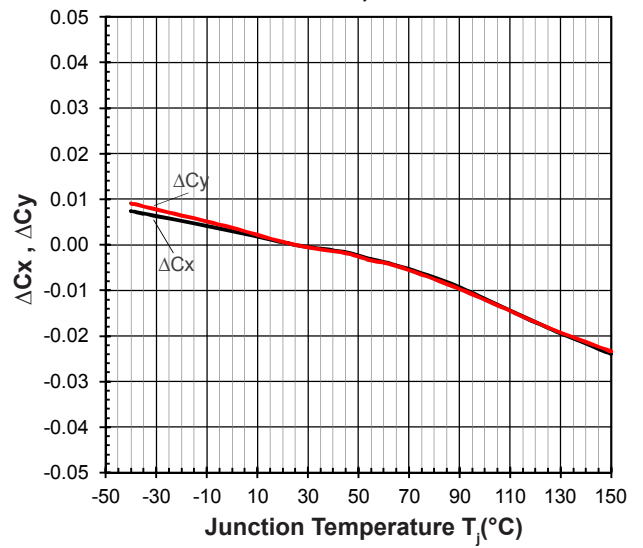

**PrimaxPlus 100 InGaN White: PQW-SSG Package Outlines**

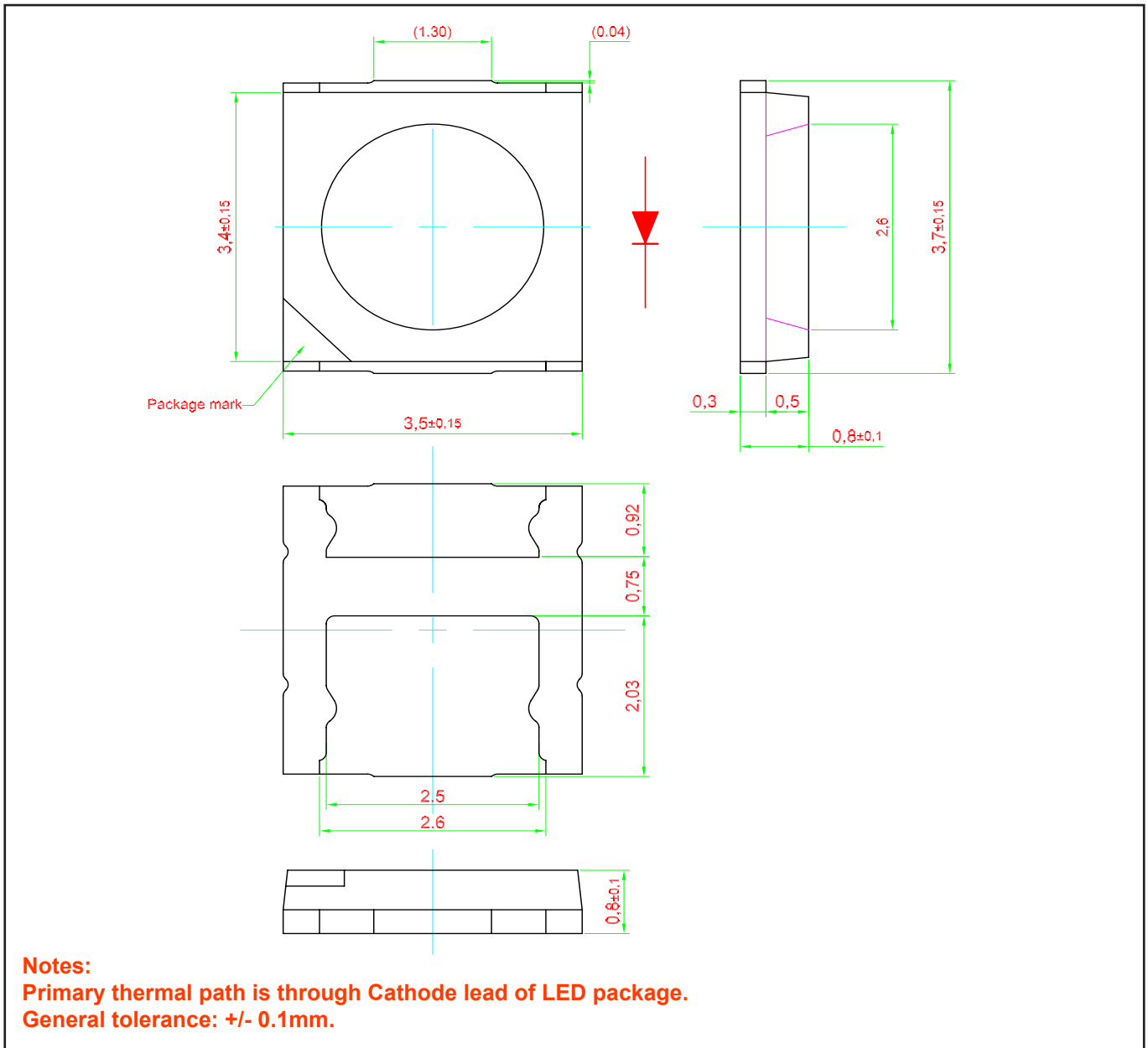

**Material**

Material	
Lead-frame	Cu Alloy With Ag Plating
Package	High Temperature Resistant Plastic
Encapsulant	Silicone Resin
Soldering Leads	NiPdAu Plating

Note: This product is Pb free



**Recommended Solder Pad**

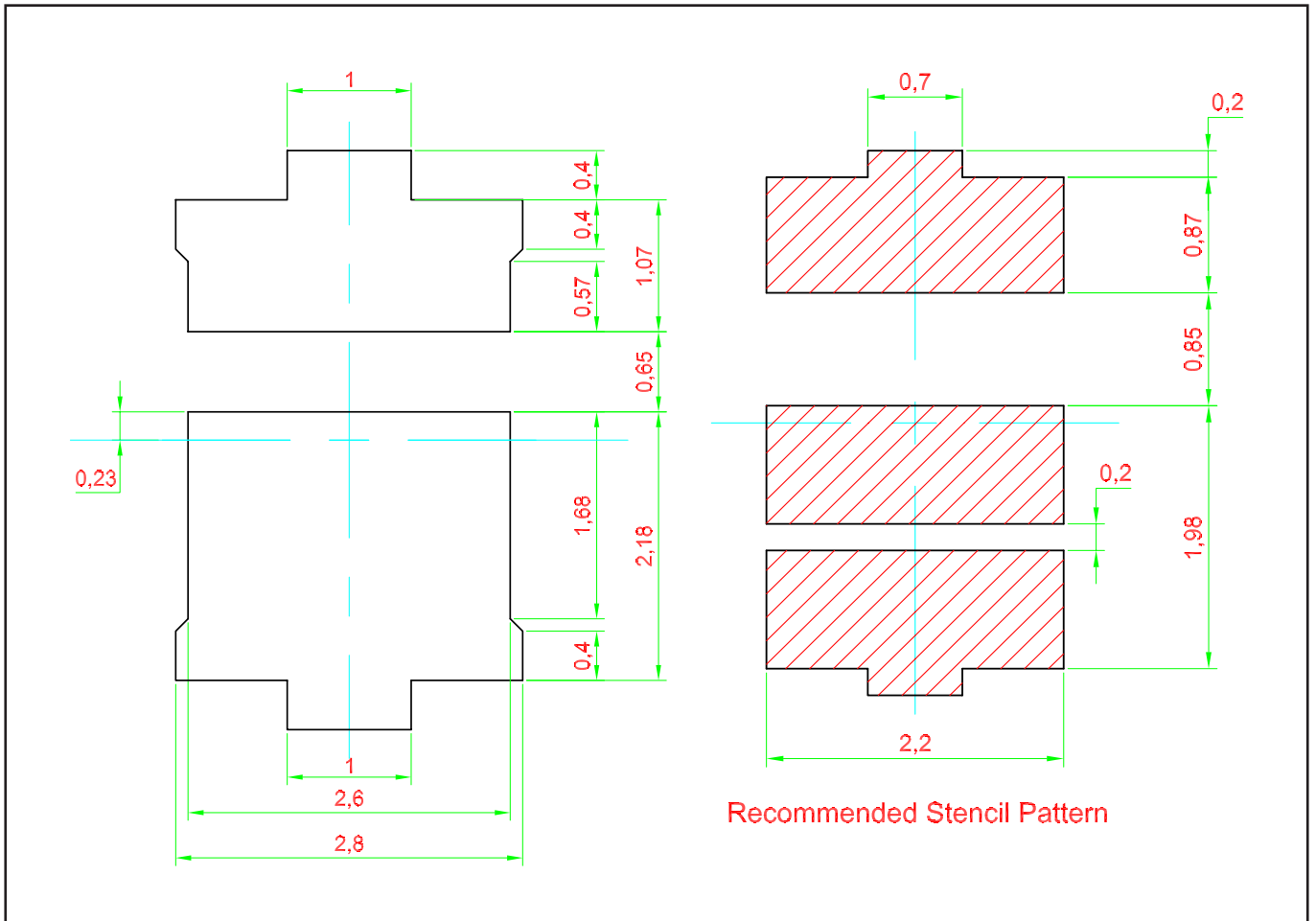

## Taping and orientation

- Reels come in quantity of 1000 units.
- Reel diameter is 180 mm.

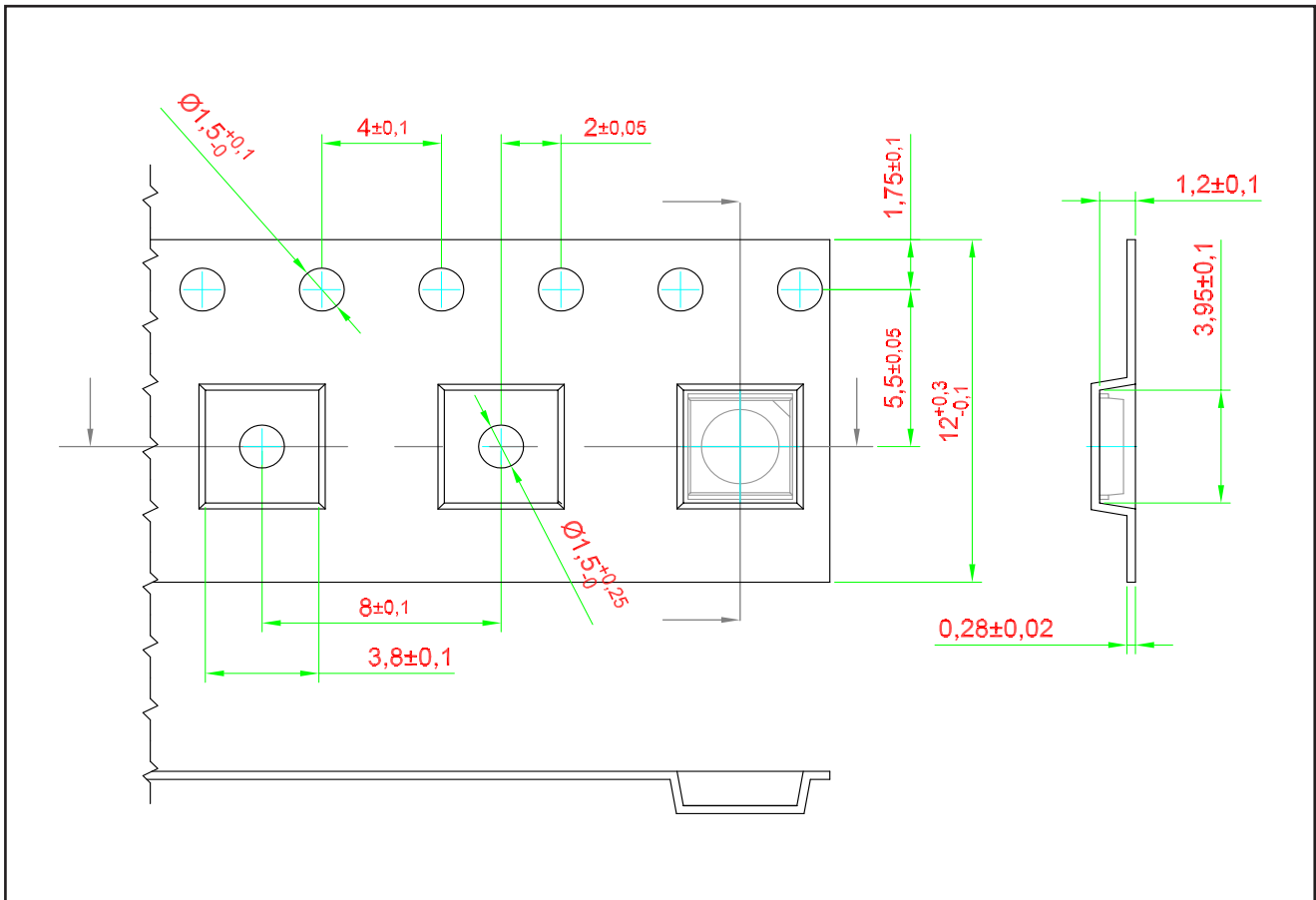

**Packaging Specification**

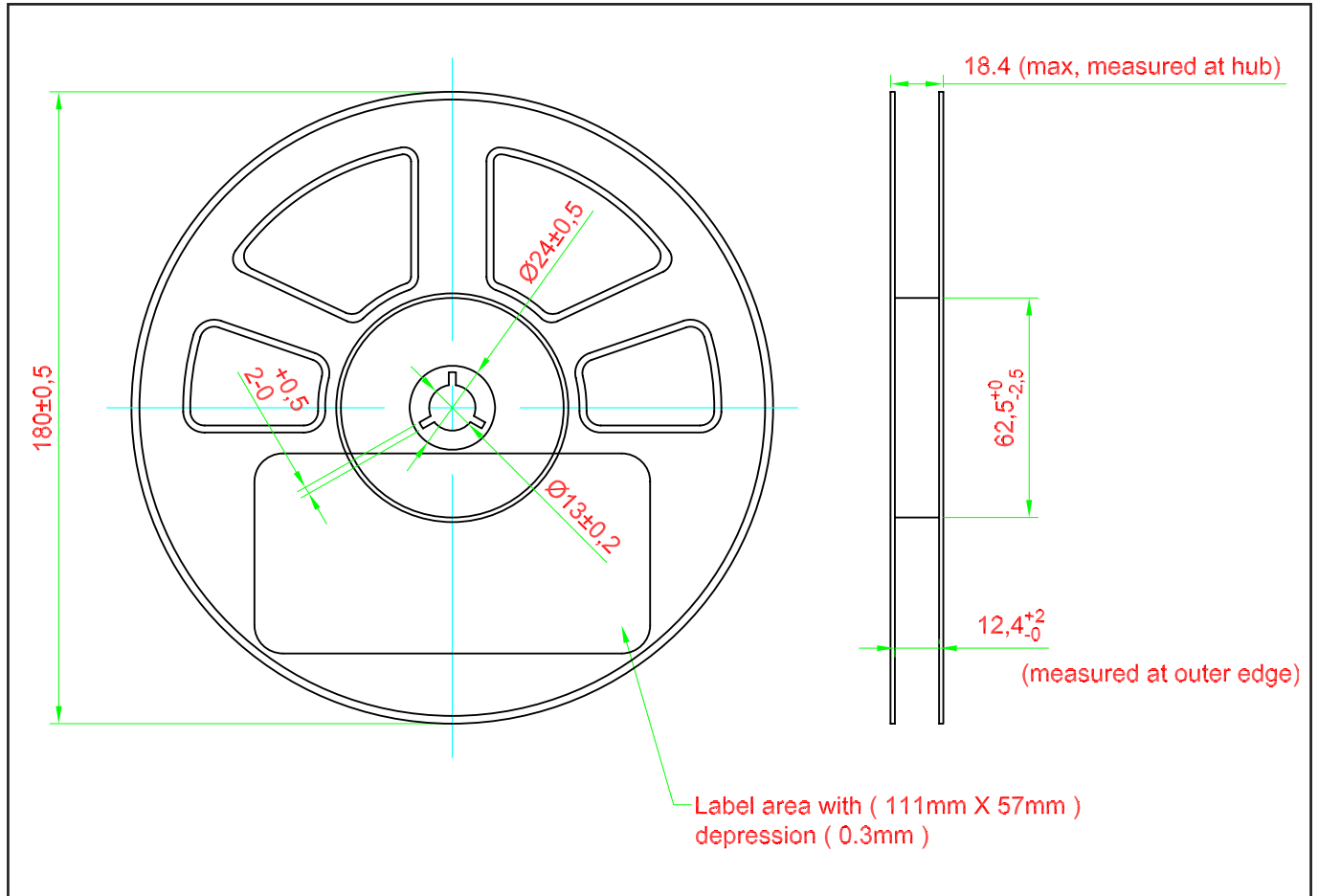

**Packaging Specification**

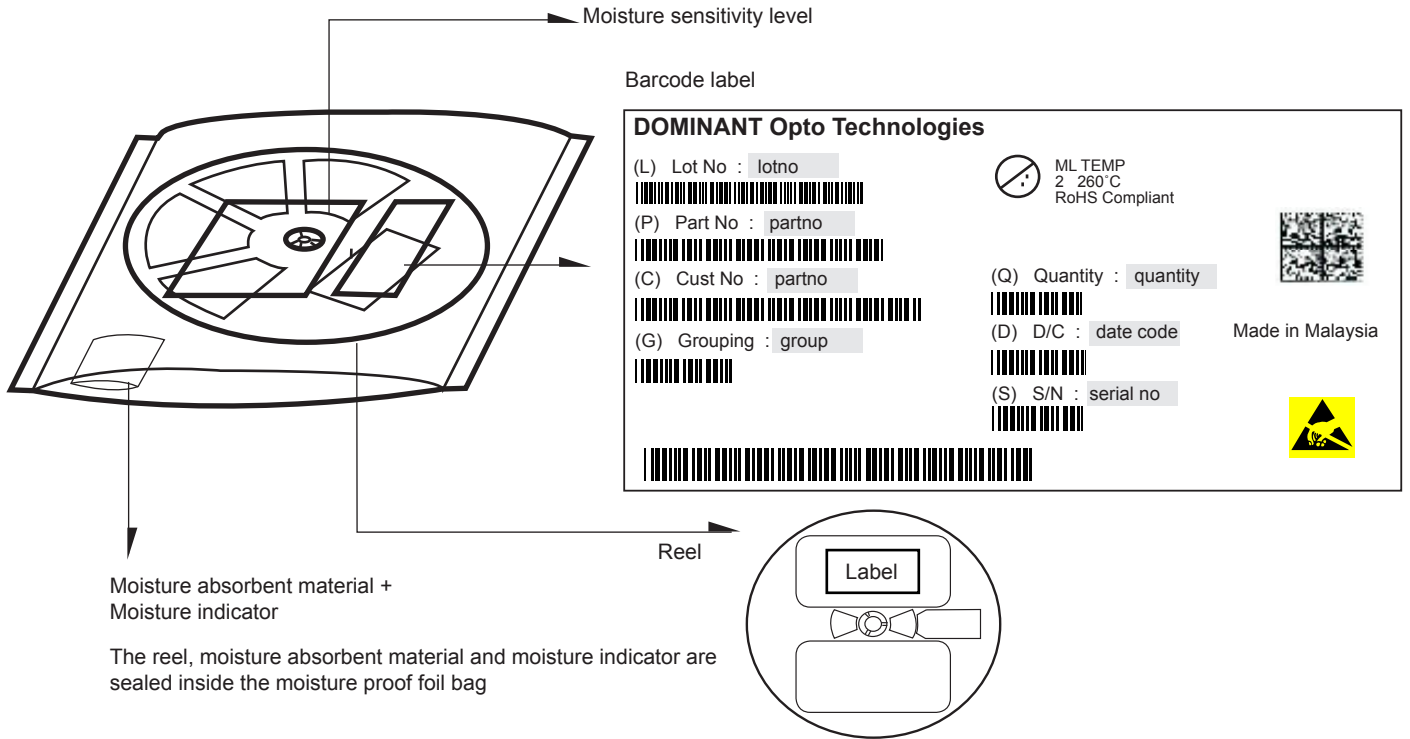

	Average 1pc PrimaxPlus	1 completed bag (1000pcs)
Weight (gram)	0.034	230 ± 10

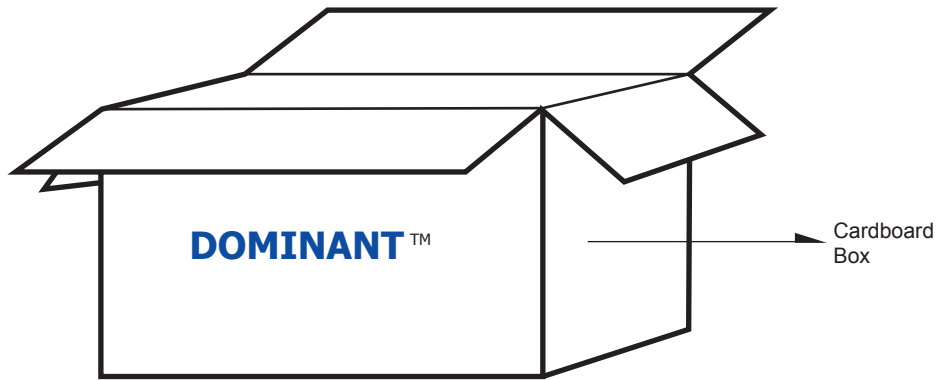

**For PrimaxPlus**

Cardboard Box Size	Dimensions (mm)	Empty Box Weight (kg)	Reel / Box
Super Small	325 x 225 x 190	0.38	7 reels MAX
Small	325 x 225 x 280	0.54	11 reels MAX
Medium	570 x 440 x 230	1.46	48 reels MAX
Large	570 x 440 x 460	1.92	96 reels MAX

**Recommended Pb-free Soldering Profile**

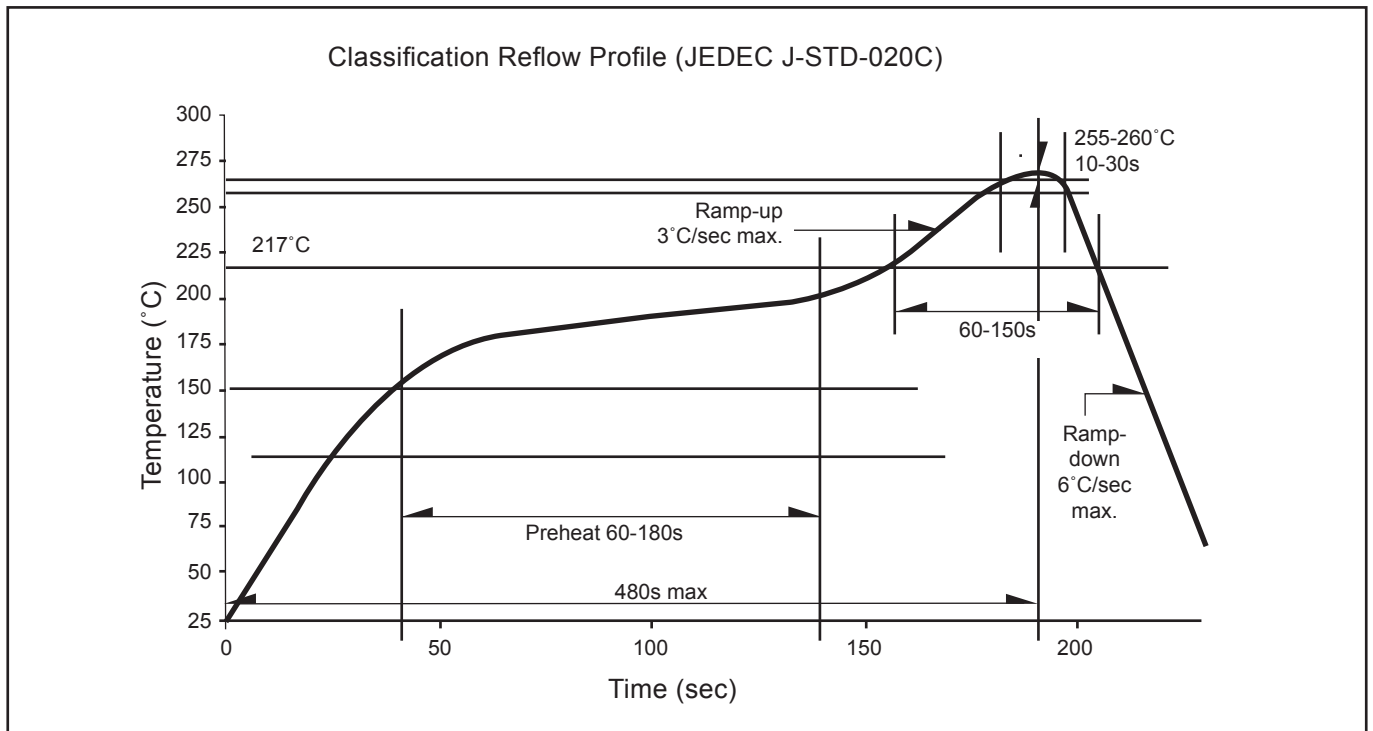

## Appendix

### 1) **Brightness:**

- 1.1 Luminous intensity is measured with an internal reproducibility of  $\pm 8\%$  and an expanded uncertainty of  $\pm 11\%$  (according to GUM with a coverage factor of  $k=3$ ).
- 1.2 Luminous flux is measured with an internal reproducibility of  $\pm 8\%$  and an expanded uncertainty of  $\pm 11\%$  (according to GUM with a coverage factor of  $k=3$ ).

### 2) **Color:**

- 2.1 Chromaticity coordinate groups are measured with an internal reproducibility of  $\pm 0.005$  and an expanded uncertainty of  $\pm 0.01$  (accordingly to GUM with a coverage factor of  $k=3$ ).
- 2.2 DOMINANT wavelength is measured with an internal reproducibility of  $\pm 0.5\text{nm}$  and an expanded uncertainty of  $\pm 1\text{nm}$  (accordingly to GUM with a coverage factor of  $k=3$ ).

### 3) **Voltage:**

- 3.1 Forward Voltage,  $V_f$  is measured with an internal reproducibility of  $\pm 0.05\text{V}$  and an expanded uncertainty of  $\pm 0.1\text{V}$  (accordingly to GUM with a coverage factor of  $k=3$ ).

### 4) **Corrosion Robustness:**

- 4.1 Test conditions:  $40\text{ }^\circ\text{C} / 90\% \text{ rh} / 15 \text{ ppm H}_2\text{S} / 336 \text{ h}$ .  
= Stricter than IEC 60068-2-43 ( $\text{H}_2\text{S}$ ) [ $25\text{ }^\circ\text{C} / 75\% \text{ rh} / 10 \text{ ppm H}_2\text{S} / 21 \text{ days}$ ].

**Revision History**

Page	Subjects	Date of Modification
-	Initial release	18 Apr 2016
8	Typo error on material	10 May 2016
12	Typo error on weight per unit	22 Jun 2016
1, 2, 6, 7, 14	Add Features Update Peak Pulse Current Update Real Thermal Resistance Update Graph: Maximum Current Vs Temperature Add Graph: Allowable Forward Current Vs Duty Ratio Add Appendix	19 Dec 2016
1, 6, 8, 9	Update Product Photo Update Graph: Forward Current Vs Forward Voltage Update Package Outline Update Recommended Solder Pad	17 May 2017
2	Add Notes: Minimum CRI of 80	10 Jul 2017

**NOTE**

All the information contained in this document is considered to be reliable at the time of publishing. However, DOMINANT Opto Technologies does not assume any liability arising out of the application or use of any product described herein.

DOMINANT Opto Technologies reserves the right to make changes to any products in order to improve reliability, function or design.

DOMINANT Opto Technologies products are not authorized for use as critical components in life support devices or systems without the express written approval from the Managing Director of DOMINANT Opto Technologies.

## About Us

DOMINANT Opto Technologies is a dynamic company that is amongst the world's leading automotive LED manufacturers. With an extensive industry experience and relentless pursuit of innovation, DOMINANT's state-of-art manufacturing and development capabilities have become a trusted and reliable brand across the globe. More information about DOMINANT Opto Technologies, a ISO/TS 16949 and ISO 14001 certified company, can be found under <http://www.dominant-semi.com>.

### **Please contact us for more information:**

DOMINANT Opto Technologies Sdn. Bhd  
Lot 6, Batu Berendam, FTZ Phase III, 75350 Melaka, Malaysia.  
Tel: +606 283 3566 Fax: +606 283 0566  
E-mail: [sales@dominant-semi.com](mailto:sales@dominant-semi.com)

---