

INTRODUCTION

The S1L9223B01 is a 1-chip BICMOS integrated circuit to perform the function of RF amp and servo signal processor for compact disc player applications.

It consists of blocks for RF signal processing, focus, tracking, sled and spindle servo. Also this IC has adjustment free function and embedded OP-AMP for audio post filter.

FEATURES

- RF amplifier & RF equalizer
- Focus error amplifier & servo control
- Tracking error amplifier & servo control
- Mirror & defect detector circuit
- Focus OK detector circuit
- APC (Auto Laser Power Control) circuit for constant laser power
- FE bias & focus servo offset adjustment free
- EF balance & tracking error gain adjustment free
- Embedded audio post filter
- The circuit for Interruption countermeasure
- Double speed play available
- Operating voltage range: S1L9223B01: 5V

80-QFP-1420C

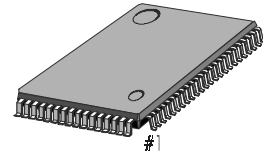

ORDERING INFORMATION

| Device | Package | Temperature Range |
|-----------------|--------------|-------------------|
| S1L9223B01-Q0R0 | 80-QFP-1420C | -20 to +70 °C |

RELATED PRODUCT

- S5L9286F01 Data Processor
- S5L9284D Data Processor
- KA9258D/KA9259D Motor Driver

BLOCK DIAGRAM

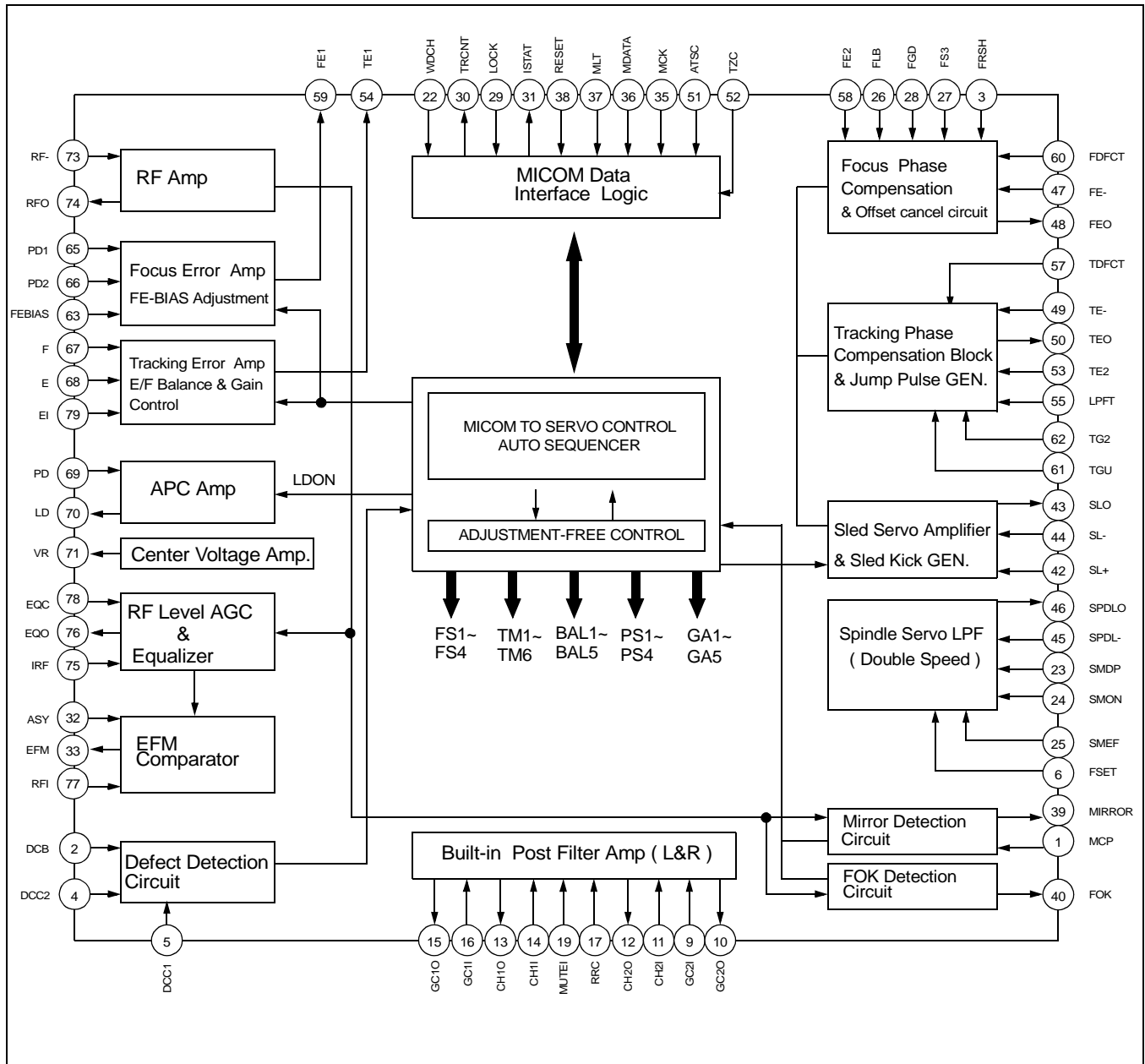

PIN CONFIGURATION

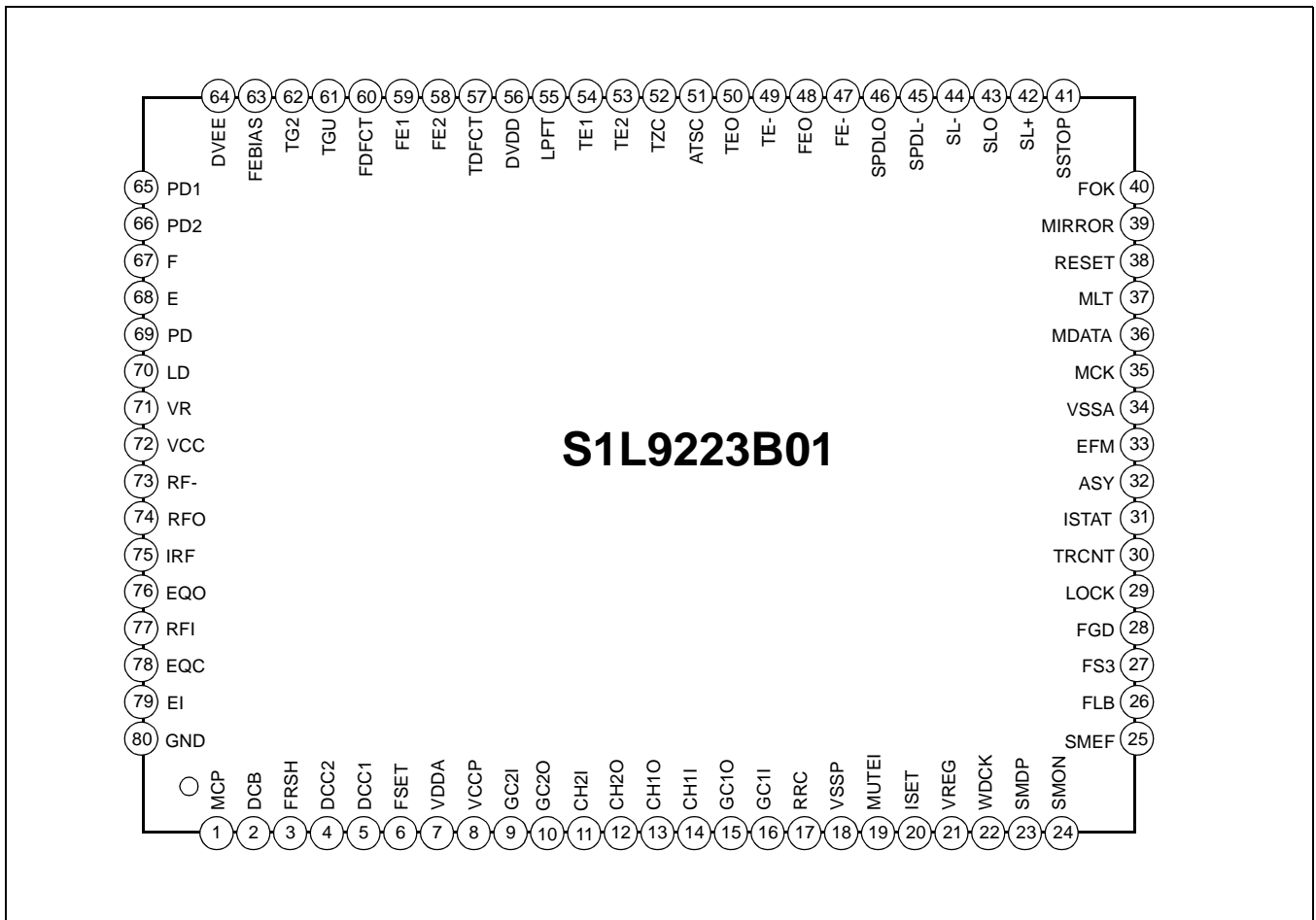

PIN DESCRIPTION

| Pin No. | Symbol | Description |
|---------|--------|---|
| 1 | MCP | Capacitor connection pin for mirror hold |
| 2 | DCB | Capacitor connection pin for defect Bottom hold |
| 3 | FRSH | Capacitor connection pin for time constant to generate focus search waveform |
| 4 | DCC2 | The input pin through capacitor of defect bottom hold output |
| 5 | DCC1 | The output pin of defect bottom hold |
| 6 | FSET | The peak frequency setting pin for focus, tracking servo and cut off frequency of CLV LPF |
| 7 | VDDA | Analog VCC for servo part |
| 8 | VCCP | VCC for post filter |
| 9 | GC2I | Amplifier negative input pin for gain and low pass filtering of DAC output CH2 |
| 10 | GC2O | Amplifier output pin for gain and low pass filtering of DAC output CH2 |
| 11 | CH2I | The input pin for post filter channel2 |
| 12 | CH2O | The output pin for post filter channel2 |
| 13 | CH1O | The output pin for post filter channel1 |
| 14 | CH1I | The input pin for post filter channel1 |
| 15 | GC1O | Amplifier output pin for gain and low pass filtering of DAC output CH1 |
| 16 | GC1I | Amplifier negative input pin for gain and low pass filtering of DAC output CH1 |
| 17 | RRC | The pin for noise reduction of post filter bias |
| 18 | VSSP | VSS for post filter |
| 19 | MUTEI | The input pin for post filter muting control |
| 20 | ISET | The input pin for current setting of focus search, track jump and sled kick voltage |
| 21 | VREG | The output pin of regulator |
| 22 | WDCK | The clock input pin for auto sequence |
| 23 | SMDP | The input pin of CLV control output pin SMDP of DSP |
| 24 | SMON | The input pin for spindle servo ON through SMON of DSP |
| 25 | SMEF | The input pin of provide for an external LPF time constant |
| 26 | FLB | Capacitor connection pin to perform rising low bandwidth of focus loop |
| 27 | FS3 | The pin for high frequency gain change of focus loop with internal FS3 switch |
| 28 | FGD | Reducing high frequency gain with capacitor between FS3 pin |
| 29 | LOCK | Sled runaway prevention pin |
| 30 | TRCNT | Track count output pin |
| 31 | ISTAT | Internal status output pin |

PIN DESCRIPTION (Continued)

| Pin No. | Symbol | Description |
|---------|--------|--|
| 32 | ASY | The input pin for asymmetry control |
| 33 | EFM | EFM comparator output pin |
| 34 | VSSA | Analog VSS for servo part |
| 35 | MCK | MICOM clock input pin |
| 36 | MDATA | MICOM data input pin |
| 37 | MLT | MICOM data latch input pin |
| 38 | RESET | Reset input pin |
| 39 | MIRROR | The mirror output for test |
| 40 | FOK | The output pin of focus OK comparator |
| 41 | SSTOP | The pin for detection whether pick_up position is innermost or not |
| 42 | SL+ | The noninverting input pin of sled servo amplifier |
| 43 | SLO | The output pin of sled servo amplifier |
| 44 | SL- | The inverting input pin of sled servo amplifier |
| 45 | SPDL- | The noninverting input pin of spindle servo amplifier |
| 46 | SPDLO | The output pin of spindle servo amplifier |
| 47 | FE- | The inverting input pin of focus servo amplifier |
| 48 | FEO | The output pin of focus servo amplifier |
| 49 | TE- | The inverting input pin of tracking servo amplifier |
| 50 | TEO | The output pin of tracking servo amplifier |
| 51 | ATSC | The input pin for Anti-shock detection |
| 52 | TZC | The comparator input pin for tracking zero crossing detection |
| 53 | TE2 | Tracking servo input pin |
| 54 | TE1 | Tracking error amplifier output pin |
| 55 | LPFT | The input pin of tracking error low pass filtering signal |
| 56 | DVDD | The power supply pin for logic circuit |
| 57 | TDFCT | The capacitor connection pin for tracking defect compensation |
| 58 | FE2 | Focus servo input pin |
| 59 | FE1 | Focus error amplifier output pin |
| 60 | FDFCT | The capacitor connection pin for focus defect compensation |
| 61 | TGU | The capacitor connection pin for high frequency tracking gain switch |
| 62 | TG2 | The pin for high frequency gain change of tracking servo loop with internal TG2 switch |

PIN DESCRIPTION (Continued)

| Pin No. | Symbol | Description |
|---------|--------|--|
| 63 | FEBIAS | Focus error bias voltage control pin |
| 64 | DVEE | The DVEE pin for logic circuit |
| 65 | PD1 | The negative input pin of RF I/V amplifier1(A+C signal) |
| 66 | PD2 | The negative input pin of RF I/V amplifier2(B+D signal) |
| 67 | F | The negative input pin of F I/V amplifier (F signal) |
| 68 | E | The negative input pin of E I/V amplifier (E signal) |
| 69 | PD | The input pin for APC |
| 70 | LD | The output pin for APC |
| 71 | VR | The output pin of $(AVEE+AVCC)/2$ voltage |
| 72 | VCC | VCC for RF part |
| 73 | RF- | RF summing amplifier inverting input pin |
| 74 | RFO | RF summing amplifier output pin |
| 75 | IRF | The input pin for AGC |
| 76 | EQO | The output pin for AGC |
| 77 | RFI | The input pin for EFM comparison |
| 78 | EQC | The capacitor connection pin for AGC |
| 79 | EI | Feedback input pin of E I/V amplifier for EF Balance control |
| 80 | GND | GND for RF part |

ABSOLUTE MAXIMUM RATINGS

| Characteristic | Symbol | Value | Unit |
|-----------------------|-----------|--------------|------|
| Supply Voltage | V_{MAX} | 6 | V |
| Power Dissipation | P_D | 200 | mW |
| Operating Temperature | T_{OPR} | -20 to + 70 | °C |
| Storage temperature | T_{STG} | -55 to + 150 | °C |

ELECTRICAL CHARACTERISTICS

($T_a=25^\circ\text{C}$, $V_{DD} = D_{VDD} = V_{CC} = +5\text{V}$, $V_{SS} = D_{VSS} = \text{GND} = V_{SSP} = 0\text{V}$)

| Characteristic | Symbol | Test Conditions | Output | Min. | Typ. | Max. | Unit |
|-------------------------------------|--------------|----------------------------------|--------|------|------|------|------|
| Supply Current High | ICCHI | $V_{CC} = 6\text{V}$, No load | – | 20 | 40 | 60 | mA |
| Supply Current Typ | ICCTY | $V_{CC} = 5\text{V}$, No Load | – | 12 | 30 | 48 | mA |
| Supply Current Low | ICCLO | $V_{CC} = 3.4\text{V}$, No Load | – | 10 | 25 | 40 | mA |
| RF Amp Offset Voltage | Vrfo | Input open | pin 74 | -80 | 0 | +80 | mV |
| RF Amp Voltage Gain | Grf | SG3 f = 10kHz, 40mVp-p, sine | pin 74 | 25.1 | 28.1 | 31.1 | dB |
| RF THD | Grfmd | SG3 f = 1kHz, 40mVp-p,sine | pin 74 | – | – | 5 | % |
| RF Amp Max. Output Voltage | Vrfpp1 | SG3 DC 2.7V | pin 74 | 3.8 | – | – | V |
| RF Amp Min. Output Voltage | Vrfpp2 | SG3 DC 2.3V | pin 74 | – | – | 1.2 | V |
| Focus Error Amp Offset Voltage | Vfeo1 | input open | pin 59 | -450 | -250 | -50 | mV |
| Focus Error Amp Auto Offset Voltage | Vfeo2 | WDCH=88.2kHz Pulse, \$841 | pin 59 | -35 | 0 | 35 | mV |
| Focus Error Amp PD1 Voltage Gain | Gfe1 | SG3 f=10kHz, 32mVp-p, sine | pin 59 | 27 | 30 | 33 | dB |
| Focus Error Amp PD2 Voltage Gain | Gfe2 | SG3 f = 10kHz, 32mVp-p, sine | pin 59 | 27 | 30 | 33 | dB |
| Focus Error Amp Voltage Difference | Gfe Δ | $\Delta Gfe1 - \Delta Gfe1$ | pin 59 | -3 | 0 | +3 | dB |
| Focus Error Amp Max. Output Voltage | Gfepp1 | SG3 DC 2.7V | pin 59 | 4.4 | – | – | V |
| Focus Error Amp Min. Output Voltage | Gfepp2 | SG3 DC2.3V | pin 59 | – | – | 0.6 | V |

ELECTRICAL CHARACTERISTICS (Continued)(Ta=25°C, V_{DD} = D_{VDD} = V_{CC} = +5V, V_{SS} = D_{VSS} = GND = V_{SSP} = 0V)

| Characteristic | Symbol | Test Conditions | Output | Min. | Typ. | Max. | Unit |
|---|--------|---|--------|-------|------|------|------|
| AGC Max Gain | Gagc | SG4 f = 500kHz, 20mVp-p, sine | pin 76 | 16 | 19 | 22 | dB |
| AGC EQ Gain | Geq | Gain Difference of Gagc at f = 1.5MHz | pin 76 | 0 | 1 | 2 | dB |
| AGC Gain2 | Gagc2 | SG4 f = 500kHz, 0.5Vp-p, sine | pin 76 | 3.5 | 6 | 9 | dB |
| AGC Compress Ratio | Cagc | Gain Difference of Gagc2 at 0.1Vp-p | pin 76 | 0 | 2.5 | 5 | dB |
| AGC Frequency | Fagc | Gain Difference SG4 f=1.5MHz,0.1Vp-p,sine and f=500kHz,0.1Vp-p,sine | pin 76 | -1.5 | 0 | 2.5 | dB |
| Tracking Error Offset Voltage | Vteo | \$800, \$820, input open | pin 54 | -50 | 0 | +50 | mV |
| Tracking Error Amp Voltage Gain F | Gtef | \$800, \$820 SG3 0.3Vp-p, 10kHz, sine | pin 54 | 2.1 | 5.1 | 8.1 | dB |
| Tracking Error Amp Voltage Gain E | Gtee | SG3 0.3Vp-p, 40kHz, sine | pin 54 | -0.75 | 2.25 | 5.25 | dB |
| Tracking Error Amp Voltage Gain Difference | GteΔ | Gtef-Gtee | pin 54 | -0.25 | 2.75 | 5.75 | dB |
| Tracking Error Amp Maximum Output Voltage H | Vtepp1 | DG3 DC 4.5V | pin 54 | 3.5 | - | - | V |
| Tracking Error Amp Minimum Output Voltage L | Vtepp2 | SG3 DC 0.5V | pin 54 | - | - | 1.5 | V |
| Tracking Error Amp Gain up F | Tguf | \$830 SG3 0.3Vp-p, 10kHz, sine | pin 54 | 8.0 | 11.0 | 14.0 | dB |
| Tracking Error Amp Gain up E | Tgue | \$830 SG3 0.3Vp-p, 10kHz, sine | pin 54 | 5.3 | 8.3 | 11.3 | dB |
| Tracking Gain Normal | Fgfn | SG3 0.3Vp-p, 10kHz, sine, \$820 | pin 54 | 2.1 | 5.1 | 8.1 | dB |
| Tracking F Gain 1 | Fgf1 | SG3 0.3Vp-p, 10kHz, sine, \$821 | pin 54 | 0.1 | 3.1 | 6.1 | dB |
| Tracking F Gain 2 | Fgf2 | SG3 0.3Vp-p, 10kHz, sine, \$822 | pin 54 | -1.7 | 1.3 | 4.3 | dB |
| Tracking F Gain 3 | Fgf3 | SG3 0.3Vp-p, 10kHz, sine, \$824 | pin 54 | -5.0 | -2.0 | 1.0 | dB |
| Tracking F Gain 4 | Fgf4 | SG3 0.3Vp-p, 10kHz, sine, \$824 | pin 54 | -9.2 | -6.2 | -3.2 | dB |

ELECTRICAL CHARACTERISTICS (Continued)(Ta=25°C, V_{DD} = D_{VDD} = V_{CC} = +5V, V_{SS} = D_{VSS} = GND = V_{SSP} = 0V)

| Characteristic | Symbol | Test Conditions | Output | Min. | Typ. | Max. | Unit |
|------------------------------|--------|---------------------------------------|--------|-------|------|------|------|
| Tracking E Balance Normal | Tben | SG3 0.3Vp-p, 10kHz, sine, \$800 | pin 54 | -0.27 | 2.27 | 5.27 | dB |
| Tracking E Balance 1 | Tbe1 | SG3 0.3Vp-p, 10kHz, sine, \$801 | pin 54 | -0.51 | 2.51 | 5.51 | dB |
| Tracking E Balance 2 | Tbe2 | SG3 0.3Vp-p, 10kHz, sine, \$802 | pin 54 | -0.74 | 2.74 | 5.74 | dB |
| Tracking E Balance 3 | Tbe3 | SG3 0.3Vp-p, 10kHz, sine, \$804 | pin 54 | 0.17 | 3.17 | 6.17 | dB |
| Tracking E Balance 4 | Tbe4 | SG3 0.3Vp-p, 10kHz, sine, \$808 | pin 54 | 1.03 | 4.03 | 7.03 | dB |
| Tracking E Balance 5 | Tbe5 | SG3 0.3Vp-p, 10kHz, sine, \$810 | pin 54 | 2.63 | 5.63 | 8.63 | dB |
| FGFN-FGF1 | ΔFG1 | - | - | 0 | 1.5 | 3 | dB |
| FGFN-FGF2 | ΔFG2 | - | - | 0.5 | 2.0 | 3.5 | dB |
| FGFN-FGF3 | ΔFG3 | - | - | 2.0 | 3.2 | 4.5 | dB |
| FGFN-FGF4 | ΔFG4 | - | - | 3.0 | 4.25 | 5.5 | dB |
| TBE5 – TBE4 | ΔTB1 | - | - | 0.6 | 1.6 | 2.6 | dB |
| TBE4 – TBE3 | ΔTB2 | - | - | -0.14 | 0.86 | 1.86 | dB |
| TBE3 – TBE2 | ΔTB3 | - | - | -0.57 | 0.43 | 1.43 | dB |
| TBE2 – TBE1 | ΔTB4 | - | - | -0.77 | 0.23 | 1.23 | dB |
| APC PSUB Voltage 1 | Vapc1 | LDON, \$853, PN=open, SG4 GND+85mV | pin 70 | - | - | 1.2 | V |
| APC PSUB Voltage 2 | Vapc2 | LDON, \$853, PN=open, SG4 GND+185mV | pin 70 | 3.8 | - | - | V |
| APC NSUB Voltage 1 | Vapc3 | LDON, \$857, PN=2.5V, SG4 GND+95mV | pin 70 | 3.8 | - | - | V |
| APC NSUB Voltage 2 | Vapc4 | LDON, \$857, PN=2.5V, SG4 GND+165mV | pin 70 | - | - | 1.2 | V |
| APC LD Off Voltage 1 | Vapc5 | LDOFF, \$85C, PN=open, SG4 2.5V | pin 70 | 4.0 | - | - | V |
| APC LD Off Voltage 2 | Vapc6 | LDOFF, \$858, PN=2.5V. SG4 2.5V | pin 70 | - | - | 1.0 | V |
| APC Maximum Output Current H | Vapc7 | LDON, \$854, PN=open, SG4 GND + 185mV | pin 70 | 2.5 | - | - | V |

ELECTRICAL CHARACTERISTICS (Continued)(Ta=25°C, V_{DD} = D_{VDD} = V_{CC} = +5V, V_{SS} = D_{VSS} = GND = V_{SSP} = 0V)

| Characteristic | Symbol | Test Conditions | Output | Min. | Typ. | Max. | Unit |
|------------------------------------|--------|--|--------|------|------|------|------|
| APC Minimum Output Current L | Vapc8 | LDON, \$854, SG4 GND + 85mV | pin 70 | – | – | 2.5 | V |
| Mirror Maximum Output Voltage H | Vmirh | SG4 2.1V+0.8Vp-p, 1kHz,sine | pin 39 | 4.3 | – | – | V |
| Mirror Minimum Output Voltage L | VmirL | SG4 2.1V+0.8Vp-p, 1kHz,sine | pin 39 | – | – | 0.7 | V |
| Mirror Minimum Operating Frequency | Fmirh | SG4 2.1V + 0.8Vp-p, 900Hz,sine | pin 39 | – | 550 | 900 | Hz |
| Mirror Maximum Operating Frequency | Fmirb | SG4 2.1V+0.8Vp-p, 30kHz,sine | pin 39 | 30 | 75 | – | KHz |
| Mirror AM Frequency Characteristic | Fmir | SG4 2.1V+0.8Vp-p 600Hz, fc=500kHz 55% modulation | pin 39 | – | 400 | 600 | Hz |
| Mirror Minimum Input Voltage | Vmir | SG4 2.1V + 0.2Vp-p, 10kHz,sine | pin 39 | – | 0.1 | 0.2 | V |
| Mirror Maximum Input Voltage | Vmih | SG4 2.1V+1.8Vp-p, 10kHz,sine | pin 39 | 1.8 | – | – | V |
| FOK Threshold Voltage | Vfokt | SG4 2.25V~2.0V,DCsweep, 10mV step | pin 40 | –420 | –360 | –300 | mV |
| FOK Output Voltage H | Vfokh | SG4 DC 1.5V | pin 40 | 4.3 | – | – | V |
| FOK Output Voltage L | VfokL | SG4 DC 2.5V | pin 40 | – | – | 0.7 | V |
| Defect Output Voltage H | Vdfcth | \$863,SG3 2.520V+0.04Vp-p f = 1kHz,sine | pin 41 | 4.3 | – | – | V |
| Output Voltage L | Vdfcth | \$863,SG3 2.520V+0.04Vp-p f = 1kHz,sine | pin 41 | – | – | 0.7 | V |
| Focus Loop Mute | Fmute | SG2 2.5V+0.1Vp-p 1kHz,sine | pin 48 | –100 | 0 | 100 | mV |
| Tracking Loop Mute | Tmute | SG2 2.5V+0.1Vp-p 1kHz,sine | pin 50 | –100 | 0 | 100 | mV |
| Interruption | Imute | SG2 2.5V+0.1Vp-p 1kHz,sine | pin 50 | –100 | 0 | 120 | mV |
| Defect Bottom Voltage | Fdfct1 | SG3 2.520 V+0.04Vp-p, 1kHz,sine | pin 41 | – | 670 | 1000 | Hz |
| Defect Max Freq. Voltage | Fdfct2 | SG3 2.520V+0.04Vp-p, 2kHz,sine | pin 41 | 2.0 | 4.7 | – | KHz |

ELECTRICAL CHARACTERISTICS (Continued)(Ta=25°C, V_{DD} = D_{VDD} = V_{CC} = +5V, V_{SS} = D_{VSS} = GND = V_{SSP} = 0V)

| Characteristic | Symbol | Test Conditions | Output | Min. | Typ. | Max. | Unit |
|---------------------------------|---------|---|--------|------|------|------|------|
| Defect Minimum Input Voltage | Vdfct1 | SG 3 2.510V+0.020Vp-p, 1kHz,sine | pin 41 | – | 0.3 | 0.5 | V |
| Defect Maximum Input Voltage | Vdfct2 | SG32.535V+0.070Vp-p, 1kHz,sine | pin 41 | 1.8 | – | – | V |
| EFM Duty Voltage 1 | Defm1 | SG4 2.5V+0.75Vp-p, 750kHz,sine | pin 32 | –50 | 0 | 50 | mV |
| EFM Duty Voltage 2 | Defm2 | SG42.75V+0.75Vp-p, 750kHz,sine | pin 32 | 0 | 50 | 100 | mV |
| EFM Minimum input Voltage | Vefm1 | SG4 2.5V+0.12Vp-p, 750kHz,sine | pin 33 | – | – | 0.12 | V |
| EFM Maximum input Voltage | Vefm2 | SG4 2.5V+1.8Vp-p 750kHz,sine | pin 33 | 1.8 | – | – | V |
| EFM Maximum Operating Frequency | Fefm | SG4 2.5V+0.75Vp-p 4MHz | pin 33 | 4 | – | – | MHz |
| FZC Threshold Voltage | Vfzc | DC 2.5V+38mV,100mV | pin 31 | 35 | 69 | 100 | mV |
| ATSC Threshold Voltage 1 | Vatasc1 | \$10,SG2 DC 2.5V-6mV –45mV | pin 31 | –67 | –32 | –7 | mV |
| ATSC Threshold Voltage 2 | Vatasc2 | SG2 DC 2.5V+6mV,+45mV | pin 33 | 7 | 32 | 67 | mV |
| TZC Threshold Voltage | Vtzc | \$20,SG2 DC 2.5V-20mV +20mV | pin 31 | –30 | 0 | 30 | mV |
| SSTOP Threshold Voltage | Vsstop | \$30,SG2 DC 2.5V-71mV –30mV | pin 31 | –100 | –50 | –30 | mV |
| Tracking gain window voltage | VtGW | \$840+\$830 SG2 2.5V 2.9V 5mV DC | pin 30 | 200 | 250 | 300 | mV |
| Tracking gain window range | VTGW2 | \$848+\$830 SG2 2.5V 5mV DC sweep | pin 30 | 100 | 150 | 200 | mV |
| Tracking balance window voltage | VTBW | \$844+\$810 SG2 2.555V ~ 2.475V 5mV DC sweep | pin 31 | –25 | 15 | 55 | mV |
| Tracking balance window range | VTBW2 | \$844+\$810 SG2 2.555V ~ 2.470V 5mV DC sweep | pin 31 | –25 | 15 | 55 | mV |
| Vreg Threshold Voltage | Vreg | – | pin 21 | 3.2 | 3.4 | 3.6 | V |

ELECTRICAL CHARACTERISTICS (Continued)(Ta=25°C, V_{DD} = D_{VDD} = V_{CC} = +5V, V_{SS} = D_{VSS} = GND = V_{SSP} = 0V)

| Characteristic | Symbol | Test Conditions | Output | Min. | Typ. | Max. | Unit |
|-------------------------------|--------|---|--------|------|------|------|------|
| Center Voltage | VCVO | 2.5V Reference | pin 71 | -100 | 0 | 100 | mV |
| VREF Current Drive Voltage 1 | VCVO1 | 2.5V Reference | pin 71 | -100 | 0 | 100 | mV |
| VREF Current Drive Voltage 2 | VCVO2 | 2.5V Reference | pin 71 | -100 | 0 | 100 | mV |
| Post CH1 Freq. Characteristic | Fpos1 | SG1 2.5V+1Vp-p 40kHz,sine | pin 13 | -4.5 | -3.0 | -1.5 | dB |
| Post CH2 Freq. Characteristic | Fpos2 | SG1 2.5V+1Vp-p 40kHz,sine | pin 12 | -4.5 | -3.0 | -1.5 | dB |
| Post CH1 Mute | Mute1 | Mute=5V SG1 2.5V+1Vp-p,1kHz,sine | pin13 | - | - | -35 | dB |
| Post CH2 Mute | Mute2 | Mute=5V SG1 2.5V+1Vp-p,1kHz,sine | pin 12 | - | - | -35 | dB |
| Focus Loop DC Gain | Gf | \$08, SG2 DC 2.6V, 2.4V average | pin 48 | 19.0 | 21.5 | 24.0 | dB |
| Focus Off Offset | Vosf1 | \$00 | pin 48 | -100 | 0 | 100 | mV |
| Focus On Offset | Vofs2 | \$08,DC 2.5V | pn 48 | 0 | 250 | 500 | mV |
| Focus Auto Offset | Vaof | \$842, WDCK, after100ms | pin 48 | -65 | 0 | 65 | mV |
| Focus Output Voltage H | Vfoh1 | \$08, DC 3.0V | pin 48 | 4.40 | - | - | V |
| Focus Output Voltage L | Vfol1 | \$08, DC 2.0V | pin 48 | - | - | 0.60 | V |
| Focus Output Drive Voltage H | Vfoh2 | \$08, DC 3.0V | pin 48 | 3.68 | - | - | V |
| Focus Output Drive Voltage L | Vfol2 | \$08, DC 2.0V | pin 48 | - | - | 1.32 | V |
| Focus Oscillation Voltage | Vosc | \$08, DC2.5V | pin 48 | 0 | 100 | 200 | mV |
| Focus Feed Through | Gff | Gain Difference at Servo on and off | pin 48 | - | - | -35 | dB |
| Focus AC Gain 1 | Gfa1 | \$08, SG2 2.5V+0.1Vp-p 1.2kHz,sine | pin 48 | 19.0 | 23.0 | 27.0 | dB |
| Focus AC Phase 1 | Pfa1 | \$08, SG2 2.5V + 0.1Vp-p 1.2kHz,sine | pin 48 | 40 | 65 | 90 | deg |
| Focus AC Gain 2 | Gfa2 | \$08, SG2 2.5V + 0.1Vp-p 2.7kHz,sine | pin 48 | 14.0 | 18.5 | 23.0 | dB |
| Focus AC Phase 2 | Pfa2 | \$08, SG2 2.5V+0.1Vp-p 2.7kHz,sine | pin 48 | 40 | 65 | 90 | deg |

ELECTRICAL CHARACTERISTICS (Continued)(Ta=25°C, V_{DD} = D_{VDD} = V_{CC} = +5V, V_{SS} = D_{VSS} = GND = V_{SSP} = 0V)

| Characteristic | Symbol | Test Conditions | Output | Min. | Typ. | Max. | Unit |
|---------------------------------|--------|--|--------|-------|-------|-------|------|
| Focus Search Voltage1 | Vfs1 | \$30+\$02 | pin 48 | -0.64 | -0.50 | -0.36 | V |
| Focus Search Voltage2 | Vfs2 | \$30+\$03 | pin 48 | 0.36 | 0.50 | 0.64 | V |
| Focus Loop Total Gain | Gftg | Focus PD gain + Focus loop DC gain | pin 48 | 49.5 | 51.5 | 53.5 | dB |
| Tracking DC Gain | Gto | \$25 SG2 DC 2.3V,2.7V average gain | pin 50 | 13.5 | 15.5 | 17.5 | dB |
| Tracking Off Offset | Vost1 | \$20 | pin 50 | -100 | 0 | 100 | mV |
| Tracking On Offset | Vost2 | SG2, DC 2.5V, \$25 | pin 50 | -100 | 0 | 120 | mV |
| Tracking Oscillation Voltage | Vosa1 | \$25, SG2 DC2.5V | pin 50 | 0 | 100 | 200 | mV |
| Tracking gain boost for ATSC | Gatasc | 2.5V + 0.1Vp-p, 1kHz, sine | pin 50 | 17.5 | 20.5 | 23.5 | dB |
| Tracking gain boost on LOCK (L) | Glock | 2.5V + 0.1Vp-p,1kHz,sine | pin 50 | 17.5 | 20.5 | 23.5 | dB |
| Tracking Output Voltage H | Vth1 | \$25,SG2 DC 1.0V | pin 50 | 4.48 | - | - | V |
| Tracking Output Voltage L | Vtl1 | \$25, SG2 , DC 4.0V | pin 50 | - | - | 0.52 | V |
| Tracking Output Drive Voltage H | Vth2 | \$25, SG2 DC2.0V | pin 50 | 3.68 | - | - | V |
| Tracking Output Drive Voltage L | Vtl2 | \$25, SG2 DC3.0V | pin 50 | - | - | 1.32 | V |
| Tracking Jump Voltage 1 | Vtj1 | \$2C | pin 50 | -0.64 | -0.5 | -0.36 | V |
| Tracking Jump Voltage 2 | Vtj2 | \$28 | pin 50 | 0.36 | 0.5 | 0.64 | V |
| Tracking Feed Through | Gtf | Gain Difference at Tracking servo on and off | pin 50 | - | - | -39 | dB |
| Tracking AC Gain 1 | Gta1 | \$10,\$25,SG2 2.5V + 0.1Vp-p, 1.2kHz,sine | pin 50 | 9.0 | 12.5 | 16.0 | dB |
| Tracking AC Phase 1 | Pta1 | \$10, \$25, SG2 2.5V+ 0.1Vp-p, 1.2kHz,sine | pin 50 | -140 | -115 | -90 | deg |
| Tracking AC Gain 2 | Gta2 | \$10, \$25, SG2 2.5V+ 0.1Vp-p, 2.7kHz, sine | pin 50 | 17.5 | 21.5 | 25.5 | dB |
| Tracking AC Phase 2 | Pta2 | \$10,\$25,SG2 2.5V + 0.1Vp-p, 2.7kHz,sine | pin 50 | -195 | -150 | -100 | deg |
| Tracking Loop Gain | Gtrt | tracking Amp F gain+ servo DC gain | - | 18.5 | 20.5 | 22.5 | dB |

ELECTRICAL CHARACTERISTICS (Continued)(Ta=25°C, V_{DD} = D_{VDD} = V_{CC} = +5V, V_{SS} = D_{VSS} = GND = V_{SSP} = 0V)

| Characteristic | Symbol | Test Conditions | Output | Min. | Typ. | Max. | Unit |
|--------------------------------|--------|---|--------|-------|------|-------|------|
| Sled DC Gain | Gsl | SG2 DC 2.6V,2.4V | pin 43 | 20.5 | 22.5 | 24.5 | dB |
| Sled Feed Through | Gslf | Gain Difference at sled servo on and off SG2 2.5V + 0.1Vp-p 1.2kHz,sine | pin 43 | – | – | –34 | dB |
| Sled Output Voltage H | Vslh1 | \$25, SG2 DC 2.9V | pin 43 | 4.48 | – | – | V |
| Sled Output Voltage L | Vsll1 | \$25, SG2 DC 2.1V | pin 43 | – | – | 0.52 | V |
| Sled Output Drive Voltage H | Vslh2 | \$25, SG2 DC 2.9V | pin 43 | 3.68 | – | – | V |
| Sled Output Drive Voltage L | Vsll2 | \$25, SG2 DC 2.1V | pin 43 | – | – | 1.32 | V |
| Sled Forward Kick Voltage | Vsk1 | \$22 | pin 43 | 0.38 | 0.60 | 0.75 | V |
| Sled Reverse Kick Voltage | Vsk2 | \$23 | pin 43 | –0.75 | –0.6 | –0.38 | V |
| Spindle Normal Speed Gain | Gsp | \$F0 SG1 DC 2.6V, 2.4V, average gain | pin 46 | 14.0 | 16.5 | 19.0 | dB |
| Spindle Double Speed Gain | Gsp2 | \$F3 SG1 DC 2.6V, 2.4V, average gain | pin 46 | 19.0 | 23.0 | 27.0 | dB |
| Spindle Output Voltage H | Gsph1 | \$F0, SG1 DC 3.5V | pin 46 | 4.48 | – | – | V |
| Spindle Output Voltage L | Gspl1 | \$F0, SG1 DC 1.5V | pin 46 | – | – | 0.52 | V |
| Spindle Output Drive Voltage H | Gsph2 | \$F0,SG1 DC 3.5V | pin 46 | 3.68 | – | – | V |
| Spindle Output Drive Voltage L | Gspl2 | \$F0,SG1 DC 1.5V | pin 46 | – | – | 1.32 | V |
| Spindle AC Gain | Gspa | \$F0,SG1 2.5V + 0.2Vp-p, 2kHz,sine | pin 46 | –7.0 | –3.5 | 0 | dB |
| Spindle AC Phase | Pspa | \$F0,SG1 2.5V + 0.2Vp-p, 2kHz,sine | pin 46 | –120 | –90 | –60 | deg |

ELECTRICAL CHARACTERISTICS (Continued)(Ta=25°C, V_{DD} = D_{VDD} = V_{CC} = +5V, V_{SS} = D_{VSS} = GND = V_{SSP} = 0V)

| Characteristic | Symbol | Test Conditions | Output | Min. | Typ. | Max. | Unit |
|-----------------------------------|--------|---|--------|-------|------|-------|------|
| Post Filter Output Voltage max. 1 | Vpom1 | SG1 2.5V + 3.2Vp-p, 1kHz, within THD 1% | pin 13 | 1.1 | 1.3 | – | Vrms |
| Post Filter Output Voltage max. 2 | Vpom2 | SG1 2.5V + 3.2Vp-p, 1kHz, within THD 1% | pin 12 | 1.1 | 1.3 | – | Vrms |
| Total Harmonic Distortion 1 | THD11 | SG1 f = 100Hz, 0dBm | pin 13 | – | 0.01 | 0.05 | % |
| Total Harmonic Distortion 1 | THD12 | SG1 f=1kHz,0dBm | pin 13 | – | 0.01 | 0.05 | % |
| Total Harmonic Distortion 1 | THD13 | SG1 f = 10kHz, 0dBm | pin 13 | – | 0.05 | 0.1 | % |
| Total Harmonic Distortion 1 | THD14 | SG1 f = 16kHz, 0dBm | pin 13 | – | 0.1 | 0.2 | % |
| Total Harmonic Distortion 1 | THD15 | SG1 f = 20kHz, 0dBm | pin 13 | – | 0.1 | 0.2 | % |
| Total Harmonic Distortion 2 | THD21 | SG1 f = 100Hz, 0dBm | Pin 12 | – | 0.01 | 0.05 | % |
| Total Harmonic Distortion 2 | THD22 | SG1 f = 1kHz, 0dBm | Pin 12 | – | 0.01 | 0.05 | % |
| Total Harmonic Distortion 2 | THD23 | SG1 f = 10kHz, 0dBm | Pin 12 | – | 0.05 | 0.1 | % |
| Total Harmonic Distortion 2 | THD24 | SG1 f = 16kHz, 0dBm | Pin 12 | – | 0.1 | 0.2 | % |
| Total Harmonic Distortion 2 | THD25 | SG1 f = 20kHz, 0dBm | Pin 12 | – | 0.1 | 0.2 | % |
| Frequency Characteristics 1 | fv11 | SG1 f = 100Hz, 0dBm | pin 13 | –0.1 | 0 | 0.1 | dB |
| Frequency Characteristics 1 | fv12 | SG1 f = 1kHz, 0dBm | pin 13 | –0.25 | 0 | +0.25 | dB |
| Frequency Characteristics 1 | fv13 | SG1 f = 10kHz, 0dBm | pin 13 | –0.5 | 0 | 0.5 | dB |
| Frequency Characteristics 1 | fv14 | SG1 f = 16kHz, 0dBm | pin 13 | –1.0 | 0 | 1.0 | dB |
| Frequency Characteristics 1 | fv15 | SG1 f = 20kHz, 0dBm | pin 13 | –1.5 | 0 | 1.5 | dB |
| Frequency Characteristics 2 | fv21 | SG1 f = 100Hz, 0dBm | Pin 12 | –0.1 | 0 | 0.1 | dB |
| Frequency Characteristics 2 | fv22 | SG1 f = 1kHz, 0dBm | Pin 12 | –0.25 | 0 | +0.25 | dB |
| Frequency Characteristics 2 | fv23 | SG1 f = 10kHz, 0dBm | Pin 12 | –0.5 | 0 | 0.5 | dB |
| Frequency Characteristics 2 | fv24 | SG1 f = 16kHz, 0dBm | Pin 12 | –1.0 | 0 | 1.0 | dB |
| Frequency Characteristics 2 | fv25 | SG1 f = 20kHz, 0dBm | Pin 12 | –1.5 | 0 | 1.5 | dB |
| Crosstalk 1 | CT11 | SG1 100Hz, 0dBm, ratio on Ch2 | pin 13 | 70 | 80 | – | dB |
| Crosstalk 1 | CT12 | SG1 1kHz, 0dBm, ratio on Ch2 | pin 13 | 65 | 75 | – | dB |
| Crosstalk 1 | CT13 | SG1 10kHz, 0dBm, ratio on Ch2 | pin 13 | 60 | 65 | – | dB |

ELECTRICAL CHARACTERISTICS (Continued)(Ta=25°C, V_{DD} = D_{VDD} = V_{CC} = +5V, V_{SS} = D_{VSS} = GND = V_{SSP} = 0V)

| Characteristic | Symbol | Test Conditions | Output | Min. | Typ. | Max. | Unit |
|-------------------------|--------|------------------------------|--------|------|------|------|------|
| Crosstalk 2 | CT21 | SG1 100Hz,0dBm,ratio on Ch1 | pin 12 | 70 | 80 | – | dB |
| Crosstalk 2 | CT22 | SG1 1kHz,0dBm,ratio on Ch1 | pin 12 | 65 | 75 | – | dB |
| Crosstalk 2 | CT23 | SG1 10kHz,0dBm, ratio on Ch1 | pin 12 | 60 | 65 | – | dB |
| Signal to Noise Ratio 1 | S/N 1 | DC 2.5V 0dbm, ratio on Noise | pin 13 | 73 | 80 | – | dB |
| Signal to Noise Ratio 2 | S/N 2 | DC 2.5V 0dbm, ratio on Noise | pin 12 | 73 | 80 | – | dB |
| Channel Balance | CB | Gain Difference Ch1 and Ch2 | – | –0.1 | 0 | +0.1 | dB |

TEST CIRCUIT

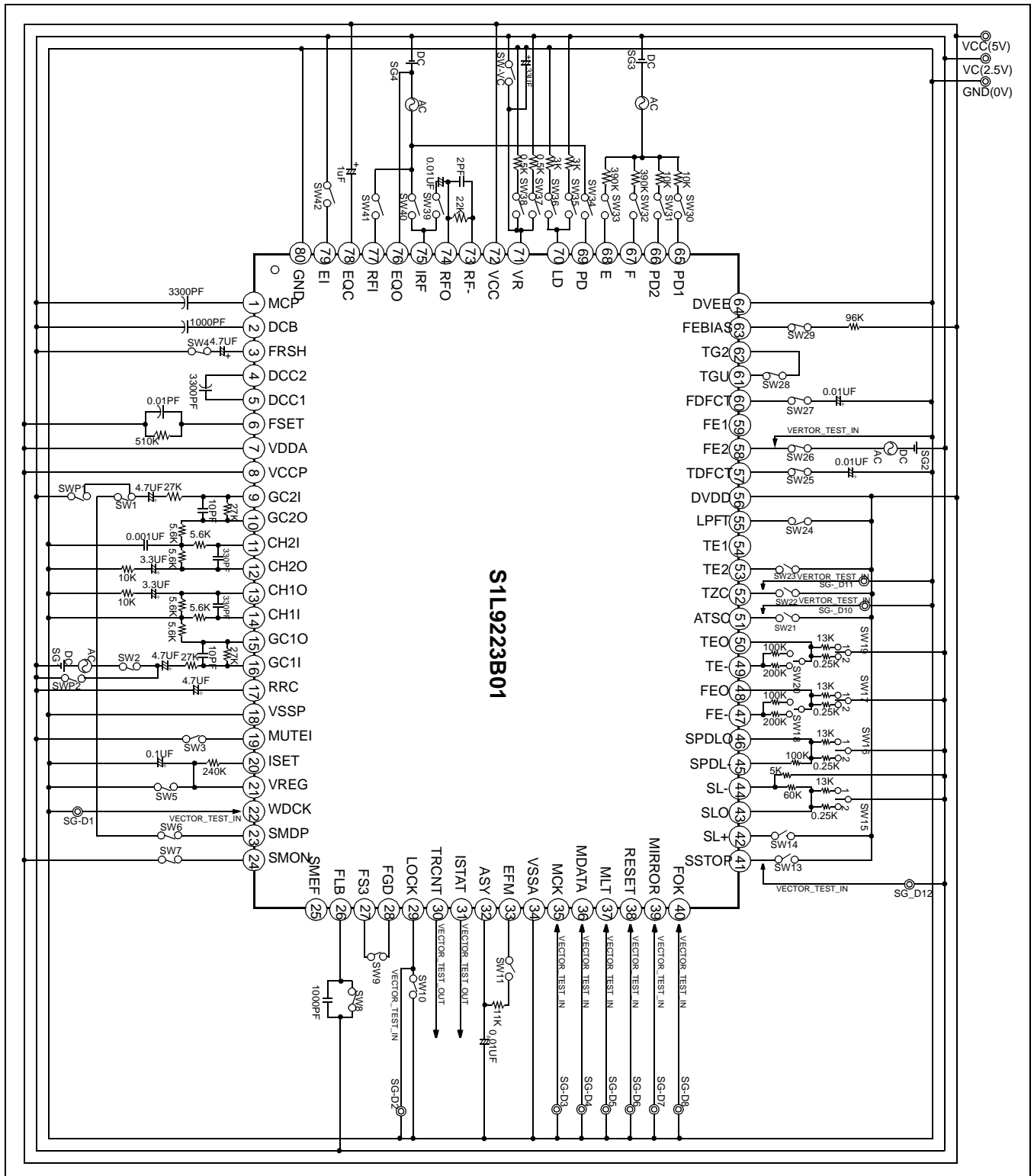

FUNCTIONAL DESCRIPTION

RF AMP BLOCK

RF AMPLIFIER

The optical currents input through pins PD1(A+C) and PD2(B+D) are converted into voltages through I-V amp, and they are added to RF summing amp. The voltage, converted from the photo diode (A+B+C+D) signal, is output through RFO (pin74) and the eye pattern can be checked at this pin.

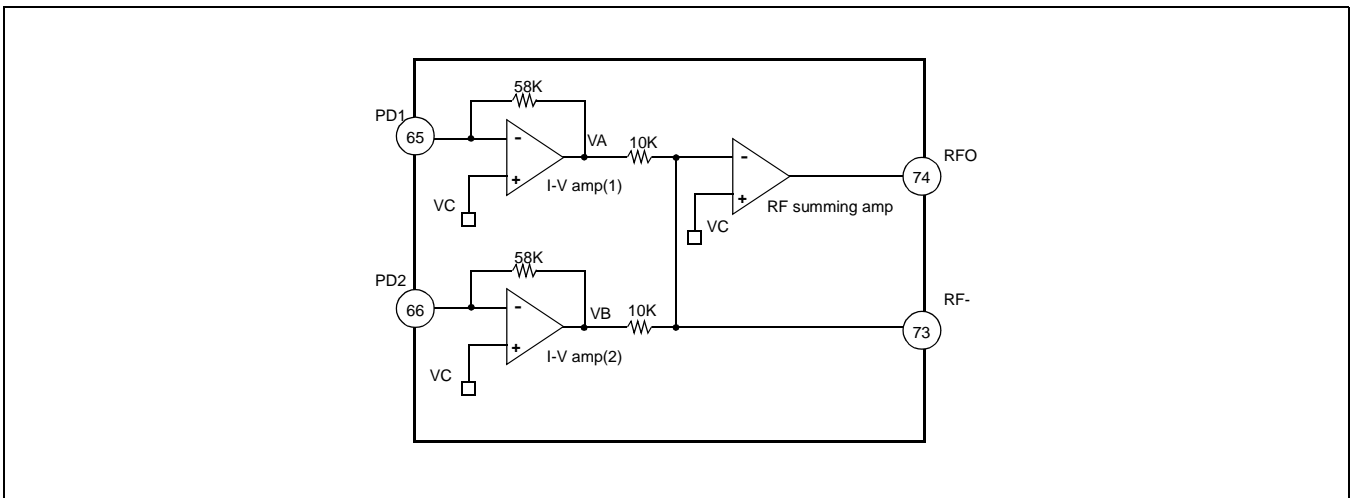

Figure 1. RF Amplifier Circuit

FOCUS ERROR AMP

The output of the focus error amp is the difference between I-V amp(1) output VA and

RF I-V amp(2) output VB. The focus error bias voltage applied to the (+) of focus error amp can be changed by output voltage of D/A converter as shown in diagram, so that the offset of focus error amp can be adjusted automatically by controlling 5 bits counter switches. Focus error bias can be adjusted from the range of +100mV — -100mV by connecting the resistor on pin 63 (FEBIAS).

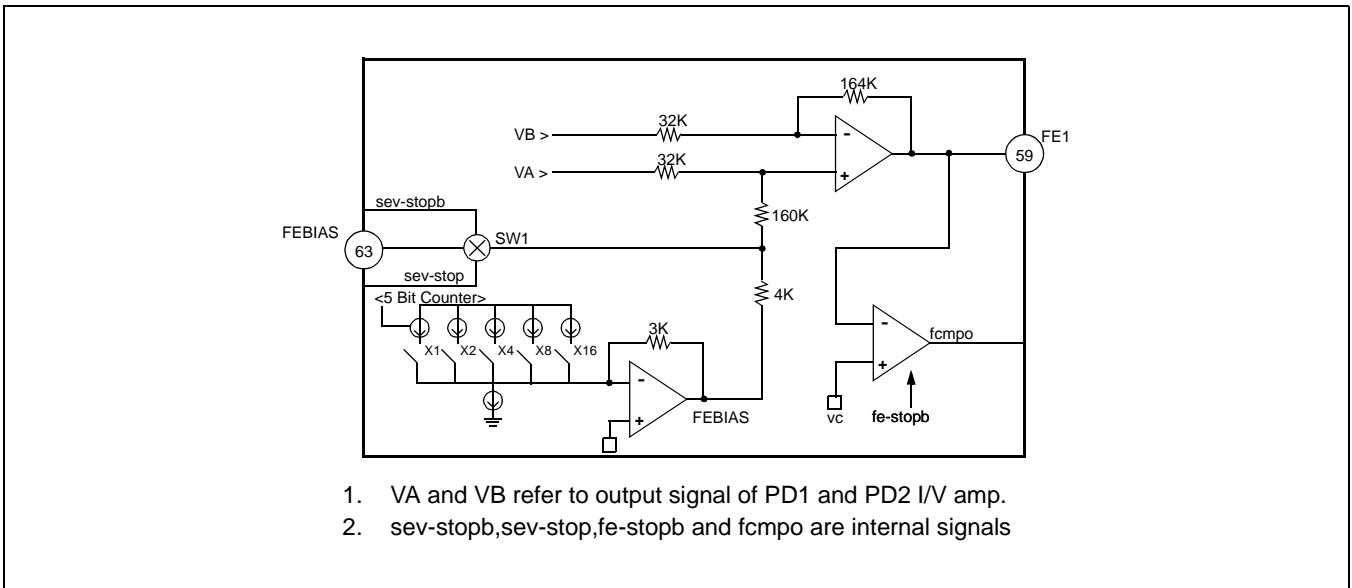

Figure 2. Focus Error Amplifier Circuit

TRACKING ERROR AMP

The optical currents detected from the side photo diode (E and F) pf pick-up are input to the E and F pin and converted into voltage signals by E I-V and F I-V amp. The output of tracking error amp generates the difference between E I-V AMP and F I-V AMP voltage output.

The E-F balance can be adjusted by modifying the gain of E I-V AMP, and the tracking gain can be adjusted automatically by controlling the peak voltage at pin TE2 by MICOM program.

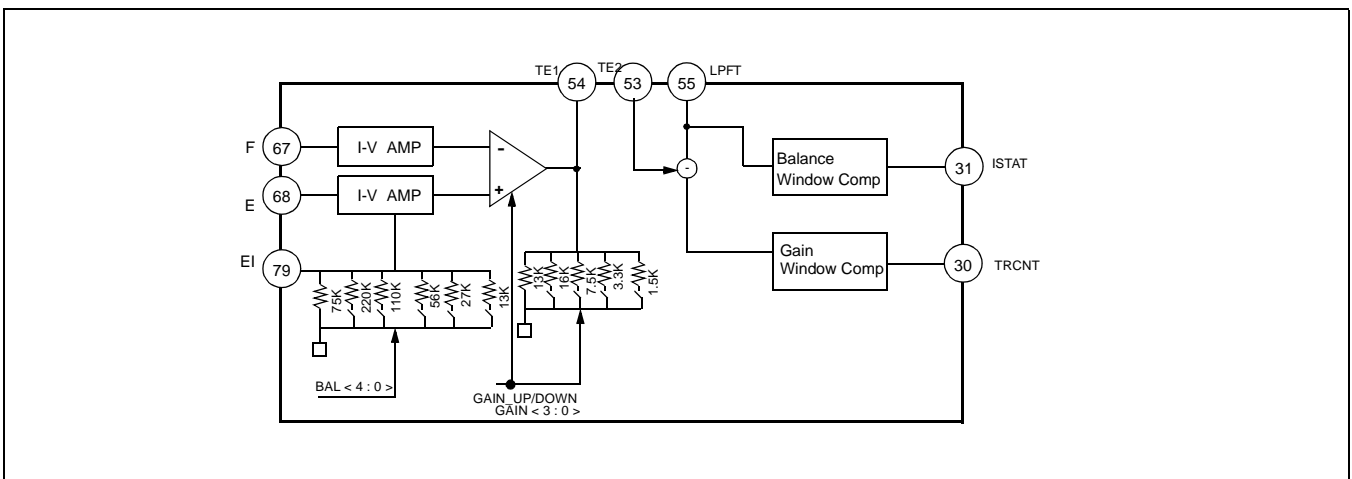

Figure 3. Tracking Error Amplifier Circuit

FOCUS OK CIRCUIT

The FOK is the output. The focus OK circuit generates a timing window to enable focus servo operation from focus search status. When the difference of the RFO (pin74) signal and DC coupled signal IRF (pin75) are above the predefined voltage the Focus OK circuit output (pin40) becomes active (High output). The predefined voltage is - 0.39V

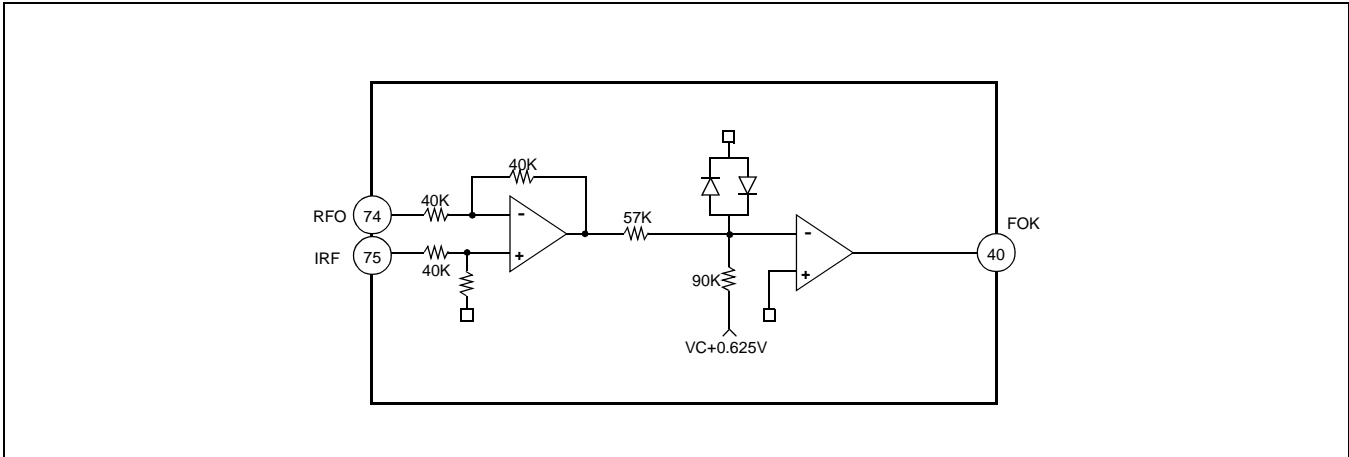

Figure 4. Focus OK Circuit

MIRROR CIRCUIT

IRF signal is amplified by the mirror amp, and the peak and bottom component of amplified signal are detected by peak and bottom hold circuit. The peak hold circuit covers traverse signal of up to 100KHz component and bottom hold circuit capable of covering the envelope frequency of disc rotation. The time constant for the mirror hold must be sufficiently larger than that of the traverse signal.

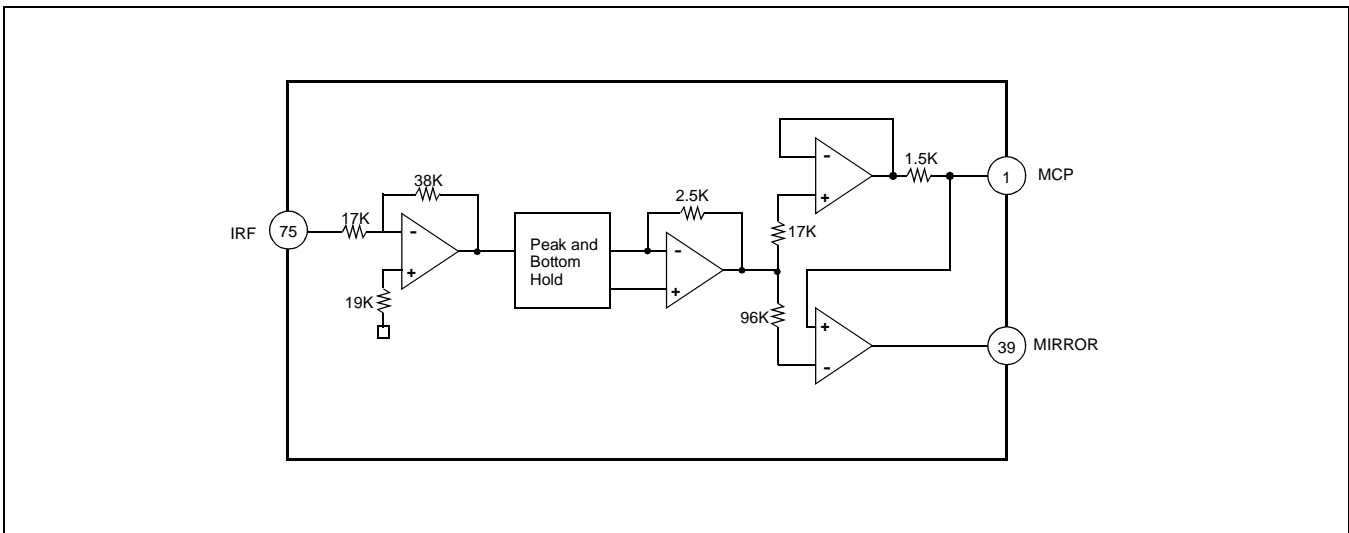

Figure 5. Mirror Circuit

EFM COMPARATOR

The EFM comparator converts a RF signal into a binary signal.

Because the asymmetry generated due to variations in disc manufacturing can not be eliminated by the AC coupling alone, this circuit uses to control reference voltage of EFM comparator for eliminating asymmetry.

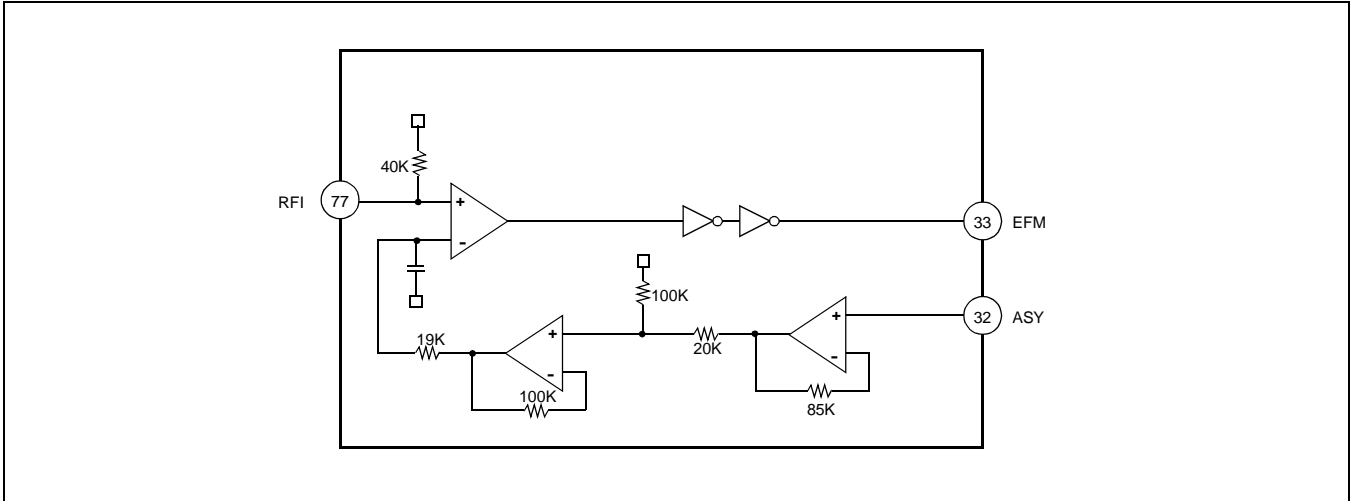

Figure 6. EFM Comparator & Asymmetry Circuit

DEFECT CIRCUIT

The RFO signal bottom, after being inverted, is held with two time constants of long and short.

The short time-constant bottom hold is done for a disc mirror defect more than 0.1msec, the long time-constant bottom hold is done with the mirror level prior to the defect. By differentiating this with a capacitor coupling and shifting the level, both signals are compared to generate the mirror defect detection signal.

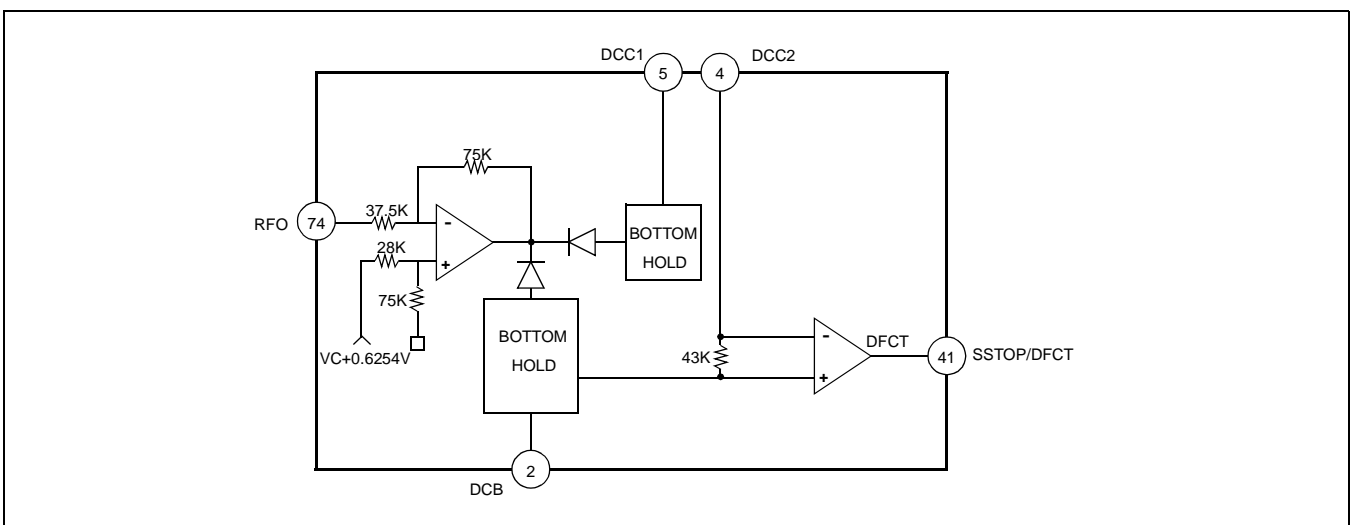

Figure 7. Defect Circuit

APC (AUTO POWER CONTROL) CIRCUIT

The laser diode has large negative temperature characteristic in its optical output when driven with a constant current on laser diode. Therefore, the output on processing monitor photo diode, must be a controlled current for getting regular output power, thus the APC (Auto Power Control) circuit is composed.

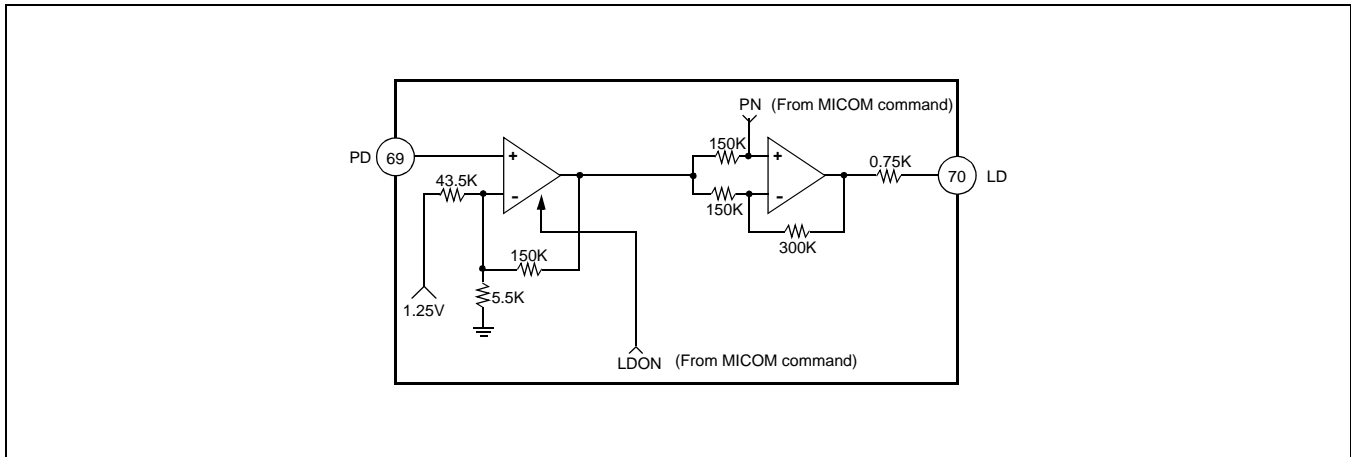

Figure 8. APC Circuit

AGC STABILITY CIRCUIT

The AGC block is the function used to maintain the constant level of RF peak to peak voltage. After the operation of RF envelop detection and comparing with reference voltage, RFO level is kept stable in 1Vp-p, and input to EFM Slice.

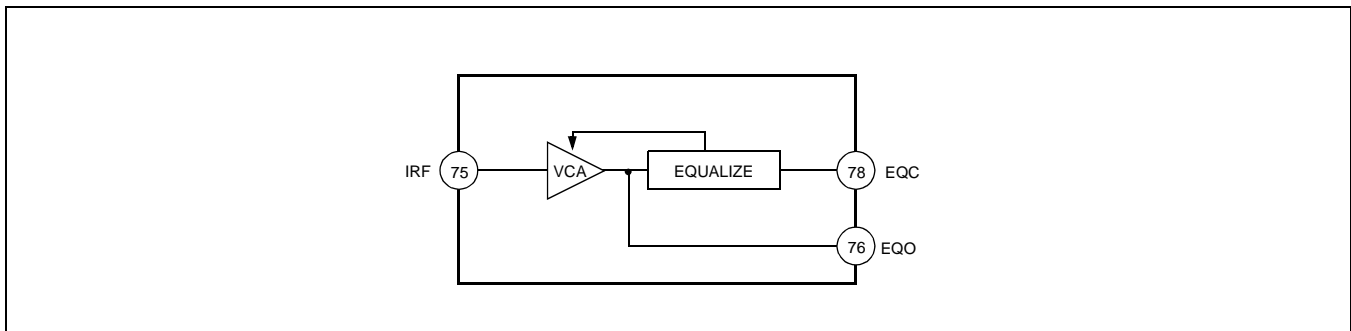

Figure 9. AGC Block

POST FILTER

The adjustment of audio output gain and the integration of possible de-emphasis output are executed by this circuit. This block has amps of 2 channel for gain and filter setting and mute pin for audio signal muting.

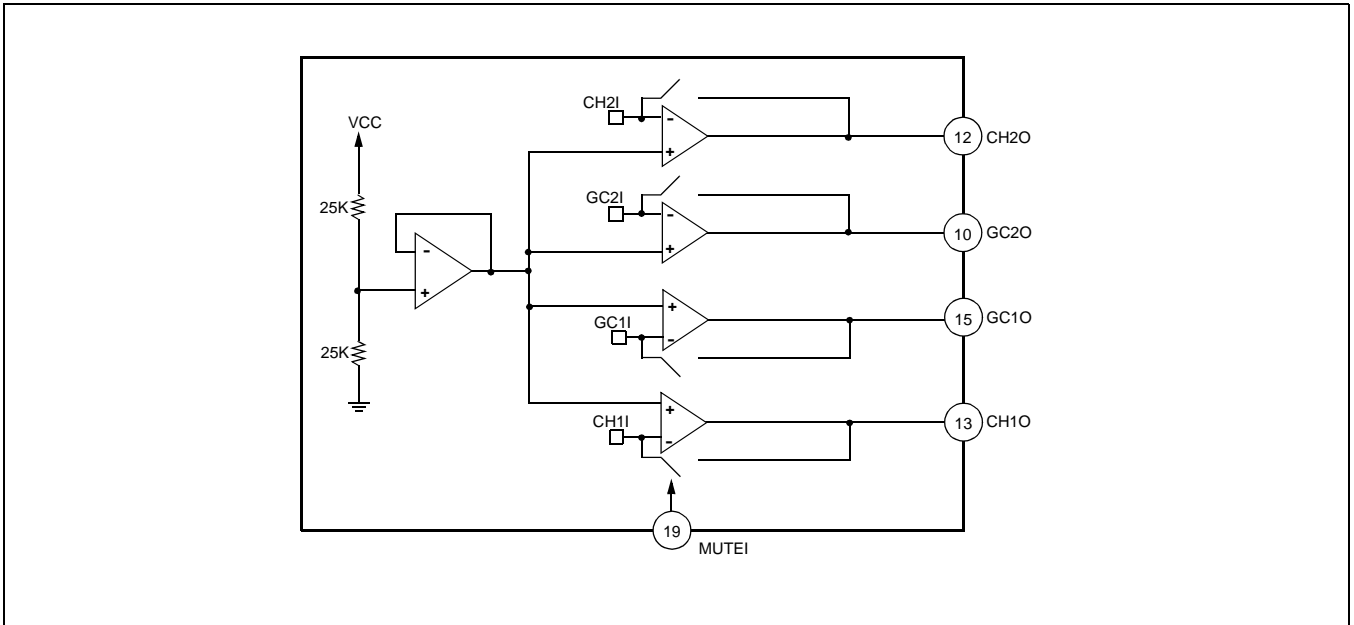

Figure 10. Post Filter Circuit

CENTER VOLTAGE GENERATION CIRCUIT

The center voltage is generated by voltage divide using resistor.

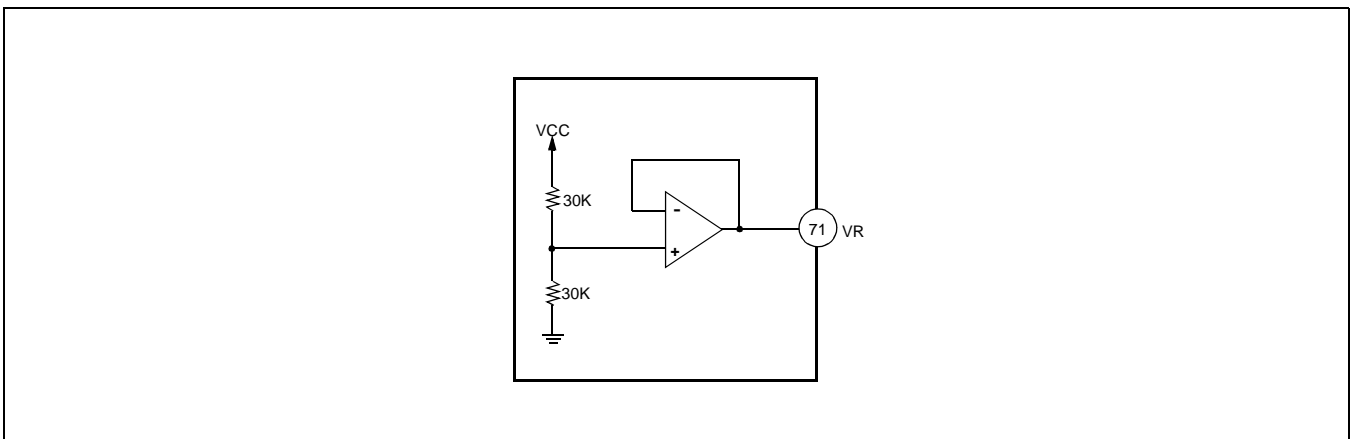

Figure 11. Center Voltage Generation Circuit

SERVO BLOCK

FOCUS SERVO BLOCK

When defect is "H" (the defect signal is detected), the focus servo loop is muting in case of focus phase compensation. At this time, the focus error signal is output through the low pass filter formed by connecting a capacitor (0.1μF) and a built-in 470KΩ resistor to the FDFCT pin (pin 60). Accordingly, the focus error output is held at the error value just before defect error during defect occurring. The peak frequency of focus loop phase compensation is at about 1.2KHz when the resistor connected to FSET pin (pin 6) is 510KΩ, and it is inversely proportional to the resistor connected to the FSET pin. While the focus search is operating, the FS4 switch is on and then the focus error signal is isolated, accordingly the focus search signal is output by FEO pin (pin 48). When the FS2 switch is on (focus on), the focus servo loop is on and the focus error signal from FE2 pin (pin 58) is output through the focus servo loop.

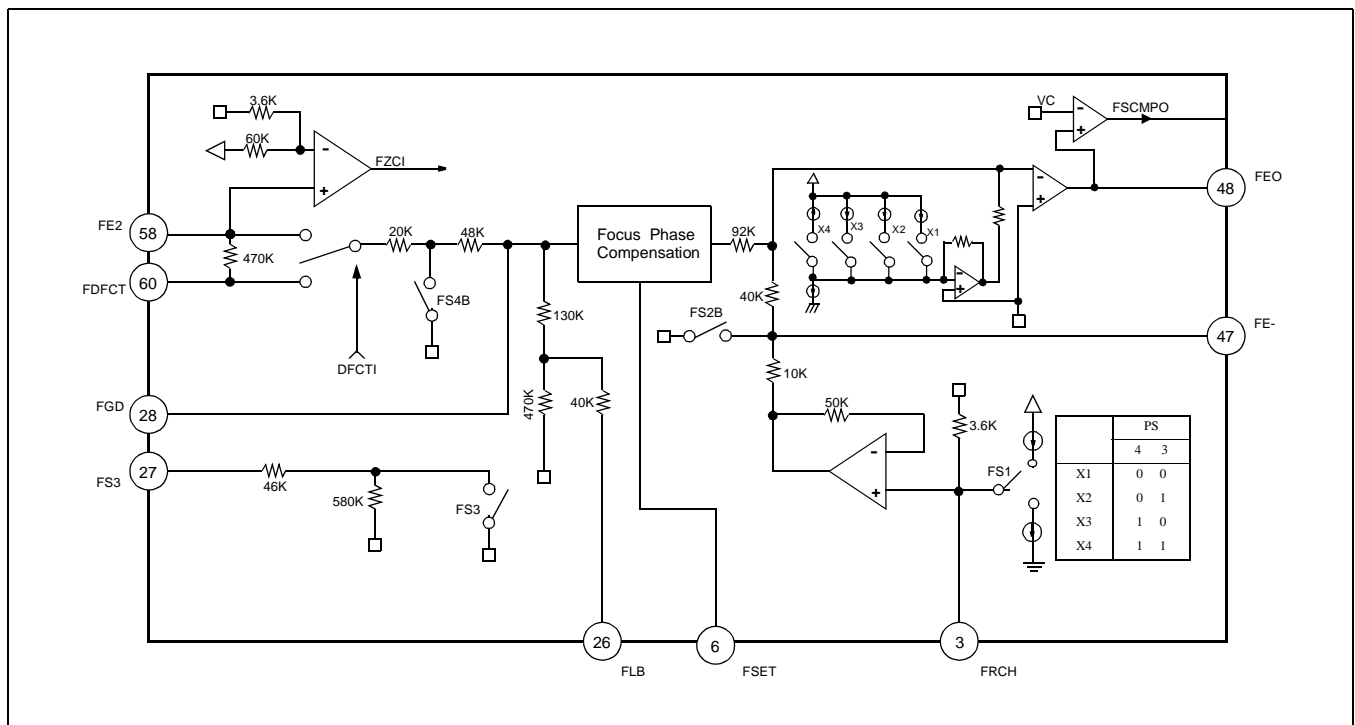

Figure 12. Focus Servo Block

TRACKING SERVO BLOCK

During detection of defect, the tracking error signal is output through the tracking servo loop after passing the low pass filter formed by connecting a capacitor (0.1 μ F) and a built-in 470K Ω resistor to the TDFCT pin (pin57) in case of tracking phase compensation. The value of tracking gain up/down can be controlled by TGU and TG2 pin. The peak frequency of tracking loop phase compensation, the dynamic range and offset of OP AMP can be adjusted by changing the value of resistor connected to FSET pin same as focus loop. In case of unstable status of actuator after jumping, the ON/OFF of tracking loop is controlled by TM7 switch of break circuit.

After 10-track jumping, servo circuit gets out of the liner range and actuator's tracking becomes occasionally unstable. Hence unnecessary jumping with many tracking error should be prevented.

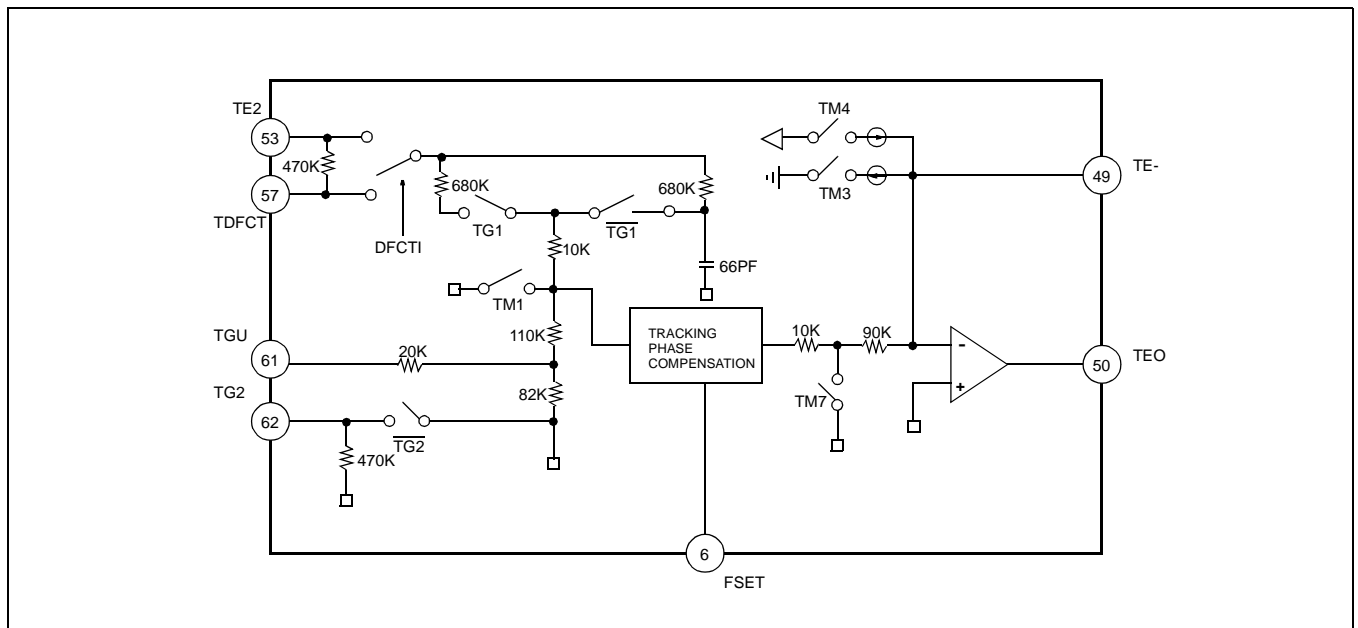

Figure 13. Tracking Servo Block

SLED SERVO BLOCK

The moving of pick-up is controlled by tracking servo output through a low pass filter. The sled kick voltage is output for track jump operation.

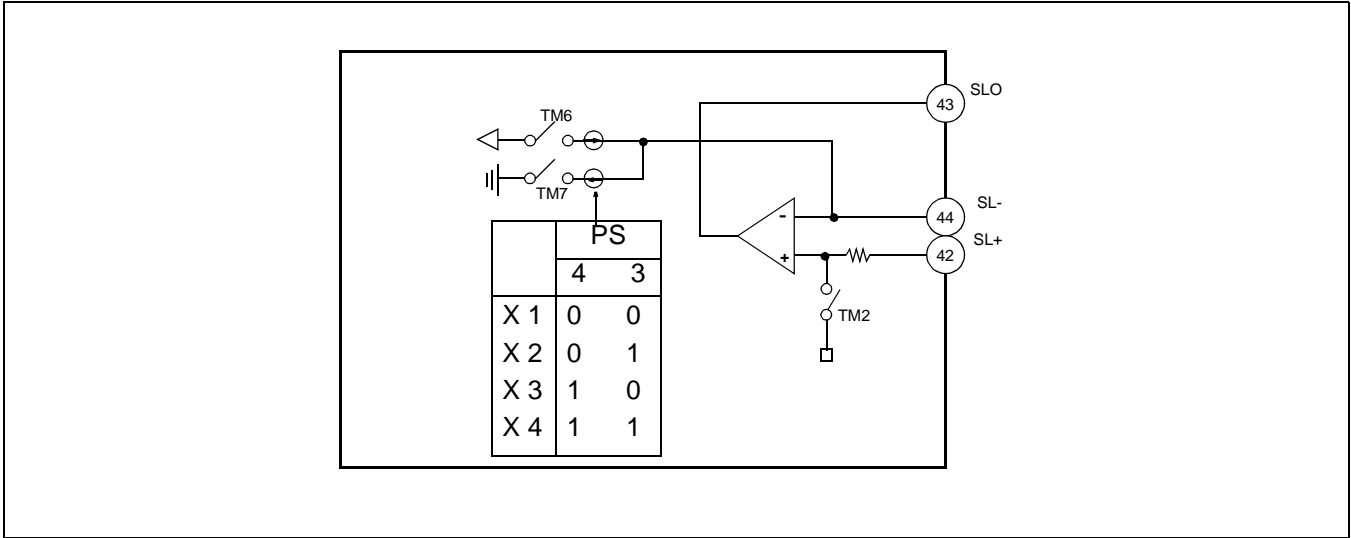

Figure 14. Sled Servo Block

SPINDLE SERVO BLOCK

The 20KΩ resistor and 0.33uF capacitor form the 200Hz low pass filter, and the carrier component of spindle servo error signals is eliminated. In CLV-S mode, SMEF becomes "L" and pin 25 low pass filter fc lowers, strengthening the filter further. The characteristics of high frequency phase compensation in focus tracking servo and the characteristics of cut off frequency in CLV low pass filter are tested by FSET pin.

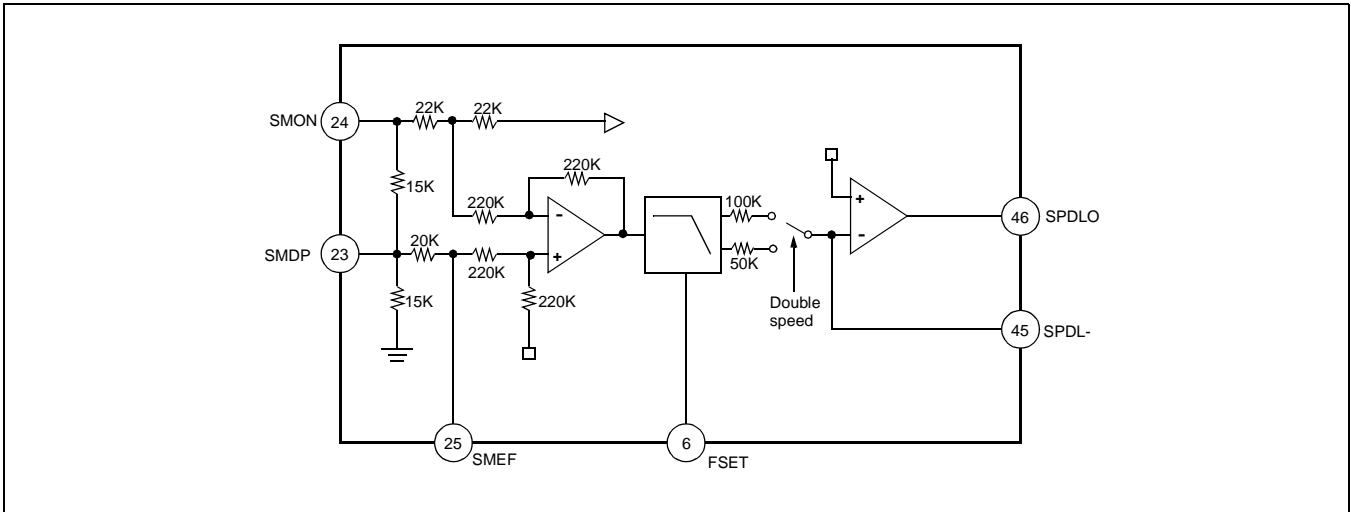

Figure 15. Spindle Servo Block

DIGITAL BLOCK

DESCRIPTION

Digital block is transferred serial data by MICOM and 8-bit serial data is converted to parallel data by serial to parallel register. This data is decoded by latch signal. The status output of focus servo, tracking servo and sled servo system,etc. It is determined by each data. The auto-sequence function process 2 — 4 MICOM command by one auto-sequence command.

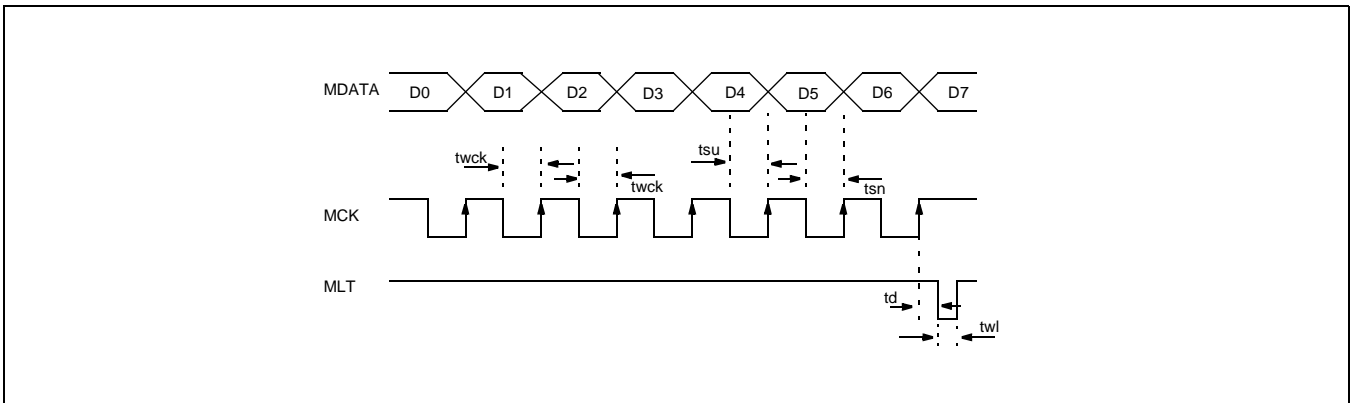

Figure 16. CPU Serial Interface Timing Chart

| Item | Symbol | Min | Typ | Max | Unit |
|-------------------|--------|------|-----|-----|------|
| Clock Frequency | fck | — | — | 1 | MHz |
| Clock Pulse Width | fwck | 500 | — | — | ns |
| Hold Time | tsu | 500 | — | — | ns |
| Setup Time | tn | 500 | — | — | ns |
| Delay Time | td | 500 | — | — | ns |
| Latch Pulse Width | twl | 1000 | — | — | ns |

MICOM COMMAND SET

| Item | Hexa | Address | | | | Data | | | | ISTAT Out | |
|--------------------------------|--------------------|---------|----|----|----|--|-----------------------|--------------------|--------------------|-----------|------|
| | | D7 | D6 | D5 | D4 | D3 | D2 | D1 | D0 | | |
| Focus Control | \$0X | 0 | 0 | 0 | 0 | FS4 Focus On | FS3 Gain Down | FS2 Search On | FS1 Search Up | FZC | |
| Tracking Control | \$1X | 0 | 0 | 0 | 1 | Anti Shock | Brake On | TG2 Gain Set | TG1 Gain Set | A.S | |
| Tracking Mode | \$2X | 0 | 0 | 1 | 0 | Tracking Mode | | Sled Mode | | TZC | |
| Select | \$3X | 0 | 0 | 1 | 1 | PS4 Focus Search+2 | PS3 Focus Search+2 | PS2 Sled Kick+2 | PS1 Sled Kick+1 | STOP | |
| Auto Sequence | \$4X | 0 | 1 | 0 | 0 | AS3 | AS2 | AS1 | AS0 | /BUSY | |
| R A M S E T | Blind/ overflow | \$5X | 0 | 1 | 0 | 1 | 0.18ms | 0.09ms | 0.045ms | 0.022ms | Hi-Z |
| | Break | | | | | | 0.36ms | 0.18ms | 0.09ms | 0.045ms | |
| | Kick | \$6X | 0 | 1 | 1 | 0 | 11.6ms | 5.80ms | 0.09ms | 0.045ms | |
| | 2N jump | \$7X | 0 | 1 | 1 | 1 | 64 | 32 | 16 | 8 | |
| | move (M) | | | | | | 128 | 64 | 32 | 16 | |
| Auto Adj. | \$8XX | 1 | 0 | 0 | 0 | Offset, Balance, Gain, APC Control | | | | - | |
| Speed | \$FX | 1 | 1 | 1 | 1 | \$F0: Normal Speed \$F3: Double Speed | | | | - | |

Focus Control (\$0X)

This command consists of 8 bits data and expressed by two hexa \$0X.

| D7 | D6 | D5 | D4 | D3 | D2 | D1 | D0 | ISTAT |
|----|----|----|----|-----|-----|-----|-----|-------|
| 0 | 0 | 0 | 0 | FS4 | FS3 | FS2 | FS1 | FZC |

FS4, FS3, FS2, FS1: internal switch for focus control

- Focus Search Operation (FS2,FS1)
 - \$02: FS2 switch become off and the value of servo output pin is as below.
(10 μ A-5 μ A)*50k*(feedback Resistor/50k)
 - \$03: If FS1 switch is 1, the current supply is cut off and the discharge is performed.
The waveform is as below and the time constant is determined by internal resistor 50K and external Cap.

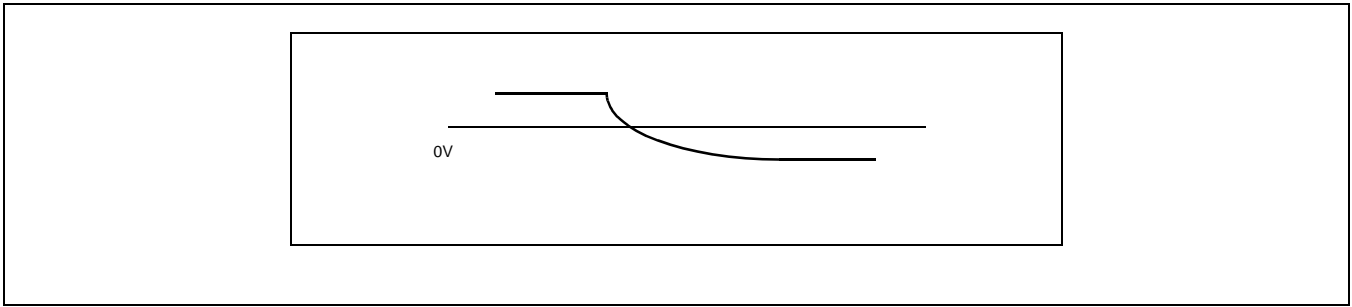

Figure 17. Waveform at Pin 3 When FS1 Is Switched from 0 to 1

The waveform of servo output pin according to FS1 and FS2 switches is as below.

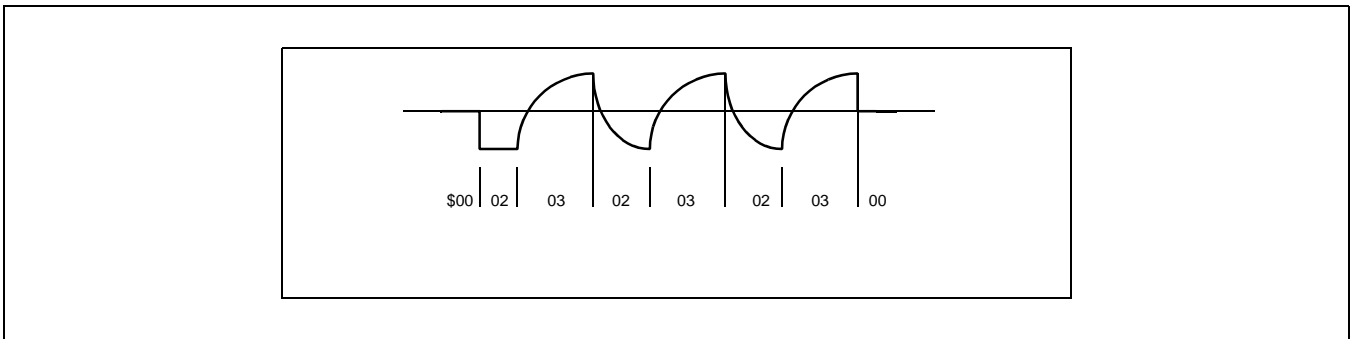

Figure 18. Focus Search Waveform at Pin 48 by \$02 and \$03

FS4 is switch for on/off control of focus servo loop

\$00: Focus servo off

\$08: Focus servo on

Tracking Control (\$1X)

This command is used for tracking loop gain control, break circuit and anti-shock on/off control.

| | | | | | | | | |
|----|----|----|----|-------------------|----------------------|-----|-----|------------|
| D7 | D6 | D5 | D4 | D3 | D2 | D1 | D0 | ISTAT |
| 0 | 0 | 0 | 1 | Anti shock on/off | Break circuit on/off | TG2 | TG1 | Anti shock |

TG2 and TG1 are internal switch for tracking gain set.

Tracking mode (\$2X)

This command is used for tracking and sled servo on/off and jump for searching track.

| | | | | | | | | |
|----|----|----|----|------------------|----|--------------|----|-------|
| D7 | D6 | D5 | D4 | D3 | D2 | D1 | D0 | ISTAT |
| 0 | 0 | 1 | 0 | Tracking control | | Sled control | | TZC |

<Tracking control & Sled control>

| D3 | D2 | Tracking mode | D1 | D0 | Sled mode |
|----|----|--------------------|----|----|----------------|
| 0 | 0 | Tracking servo off | 0 | 0 | Sled servo off |
| 0 | 1 | servo on | 0 | 1 | servo on |
| 1 | 0 | Forward jump | 1 | 0 | Forward kick |
| 1 | 1 | Reverse jump | 1 | 1 | Reverse kick |

Peak value set (\$3X)

This command is used for the peak value setting of focus search and sled kick.

D0, D1: Sled kick

D2, D3: Focus search peak value

Auto Sequencer command (\$4X)

This command is used for reducing control time and replacing several command by one auto- sequence command.

- Auto sequencer mode is performed from the first falling edge of WDCK clock after the falling of the latch pulse.
- Auto sequencer does not carry out tracking gain up, brake, anti-shock and focus gain down.
- MICOM checks ISTAT pin (/BUSY) and sends to \$40 command to reset preceding auto sequencer status

| | Hexa | AS3 | AS2 | AS1 | AS0 | Remark |
|---------------|------|-----|-----|-----|-----|---------|
| Cancel | \$40 | 0 | 0 | 0 | 0 | Reset |
| Auto focus | \$47 | 0 | 1 | 1 | 1 | – |
| 1 Track jump | \$48 | 1 | 0 | 0 | 0 | Forward |
| | \$49 | 1 | 0 | 0 | 1 | Reverse |
| 10 Track jump | \$4A | 1 | 0 | 1 | 0 | Forward |
| | \$4B | 1 | 0 | 1 | 1 | Reverse |
| 2N track jump | \$4C | 1 | 1 | 0 | 0 | Forward |
| | \$4D | 1 | 1 | 0 | 1 | Reverse |
| M track move | \$4E | 1 | 1 | 1 | 0 | Forward |
| | \$4F | 1 | 1 | 1 | 1 | Reverse |

RAM Set (\$5X — \$7X)

The value of RAM set is somewhat different to the actual count and the initial value is like below

| Item | Initial value | Actual Count Value |
|------------------|---------------|-----------------------------|
| Blind | \$55 | Set value +4 — 5 WDCK clock |
| overflow, Brake | | Set value +3 WDCK clock |
| Kick | \$67 | Set value +5 WDCK clock |
| 2N, M Track jump | \$7E | Set value +3 WDCK clock |

AUTO ADJUSTMENT COMMAND

This command is used for auto control of offset, balance, gain adjustment and reference voltage setting. This command is also in control of on/off and sub type of laser diode and test or set mode.

TRACKING BALANCE (\$800 — \$81F)

| Item | Hexa | Data (5bits) | Initial value | ISTAT (pin31) | TRCNT (pin30) |
|------------------|---------------|--------------|---------------|---------------|---------------|
| Tracking balance | \$800 — \$81F | D4 — D0 | \$81F | BAL | TRCNT |

TRACKING GAIN (\$820 — \$83F)

| Item | Hexa | Data 5bits) | Initial value | ISTAT (pin31) | TRCNT (pin30) |
|---------------|---------------|-------------|---------------|---------------|---------------|
| Tracking gain | \$820 — \$83F | D4 — D0 | \$820 | GAIN | TGL |

TRACKING BALANCE & GAIN WINDOW LEVEL SETTING

| Item | Hexa | D3 | D2 | D1 | D0 | Initial value |
|----------------------|-------|------|---------|----|----|---------------|
| window level setting | \$84X | gain | balance | 0 | 0 | \$840 |

NOTE: The tracking balance and gain window level is set by D2,D3 data and the value has two kinds of window levels set

TRACKING BALANCE WINDOW LEVEL

| D2 Data | 0 | 1 |
|-------------------------------|---------------|---------------|
| Tracking balance window level | -10 to +15 mV | -20 to +20 mV |

TRACKING GAIN WINDOW LEVEL

| D3 Data | 0 | 1 |
|----------------------------|---------------|---------------|
| Tracking gain window level | 250 to 400 mV | 150 to 300 mV |

FOCUS LOOP OFFSET ADJUSTMENT START COMMAND (\$841, \$842)

This command is used for adjusting focus error bias and removing focus servo offset. It is executed during laser diode off.

| Hexa command | meaning |
|--------------|--|
| \$841 | Focus error bias adjustment start command |
| \$842 | Focus servo offset cancel adjustment start command |

APC CIRCUIT OPERATION AND INTERRUPTION ON/OFF SETTING CONDITION (\$85X)

This command is used for setting of laser diode on/off, sub type (P_sub or N_sub) of laser diode and interruption countermeasure circuit on/off.

| Item | Hexa | D3 | D2 | D1 | D0 | Initial value |
|-------------------------------------|-------|------------------------------|----------------------------------|--------------------------------------|----|---------------|
| APC & Interruption on/off condition | \$85X | LD on/off 0: On 1: Off | Sub-type 0: N_sub 1: P_sub | Interruption ON/OFF and time setting | | \$858 |

Time setting for Interruption countermeasure circuit on/off

| D1 | D0 | Meaning |
|----|----|---|
| 0 | 0 | Countermeasure circuit on for all mirror signal |
| 0 | 1 | Countermeasure circuit on up to 20kHz mirror signal |
| 1 | 0 | Countermeasure circuit off |
| 1 | 1 | Countermeasure circuit on up to 10kHz mirror signal |

FOCUS SERVO OFFSET RESET COMMAND AND SET MODE COMMAND (86X)

This command is used for set and release before focus servo loop offset adjustment and mode change.

| Item | Hexa | D3 | D2 | D1 | D0 |
|---|-------|--------------------------------------|---|----|----|
| Set mode & Focus servo offset reset command | \$86X | 0: offset release 1: offset reset | option(Pin41 output) 0: Defect 1: SSTOP | 1 | 1 |

NOTES:

1. The set mode command is sent by MICOM right after tracking gain is tuned.
2. The ISTAT pin is outputted the internal status of \$00 ~ \$7X command.

DIRECT COMMAND (DIRC) AND FOCUS BIAS RESET COMMAND (\$87X)

This command is used for direct 1 track jump on/off setting and focus bias adjustment set and release

| Item | Hexa | D3 | D2 | D1 | D0 |
|-------------------------|-------|--------------------------|------------------------------|----|----|
| DIRC & focus bias reset | \$87X | 0: DIRC On 1:DIRC Off | 0: reset 1: reset release | X | X |

THE EXAMPLE OF ADJUSTMENT FREE ALGORITHM

FOCUS ERROR BIAS & SERVO OFFSET CANCEL ADJUSTMENT

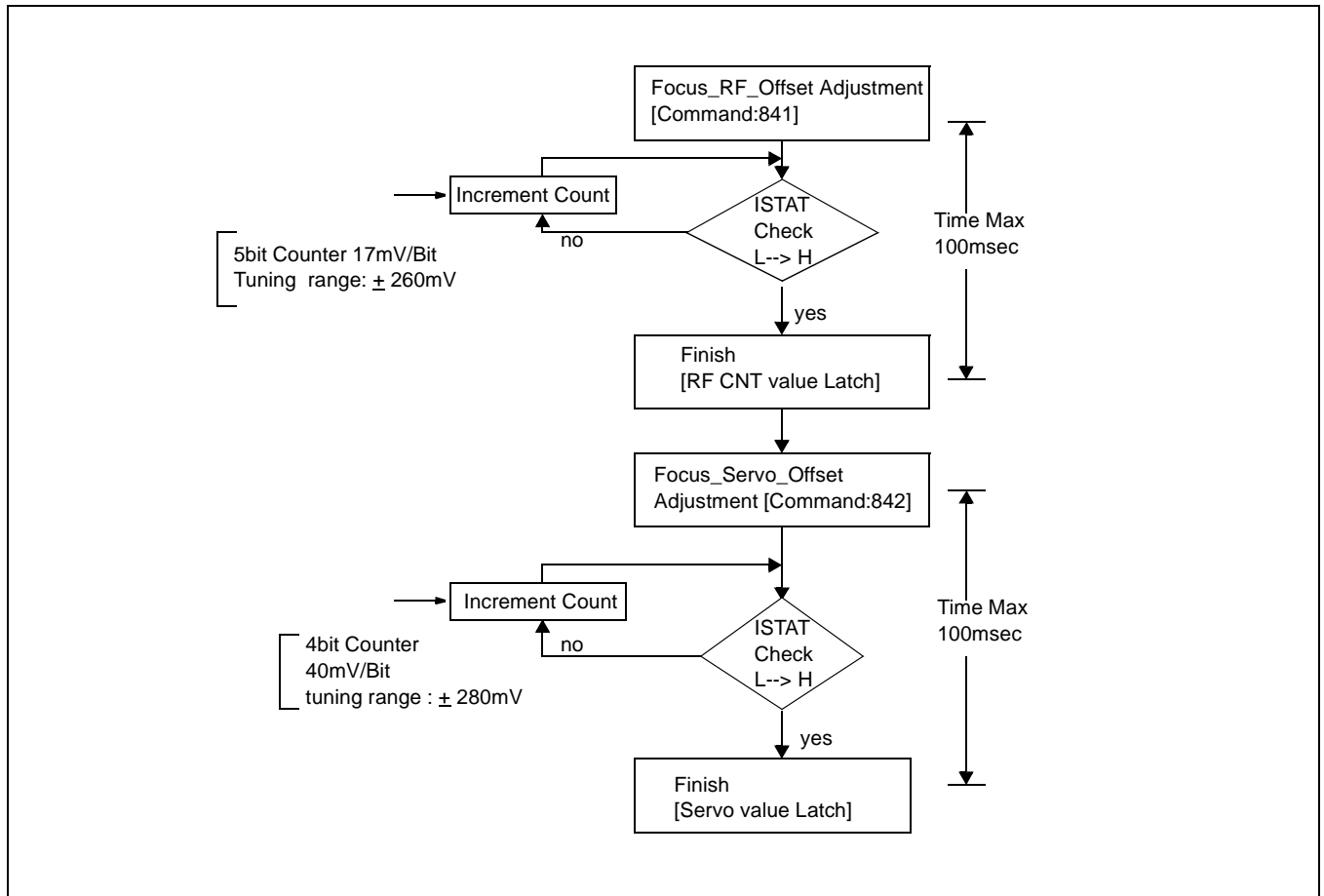

Figure 19. Focus Error Bias & Servo Offset Cancel Adjustment Flow Chart

TRACKING BALANCE ADJUSTMENT

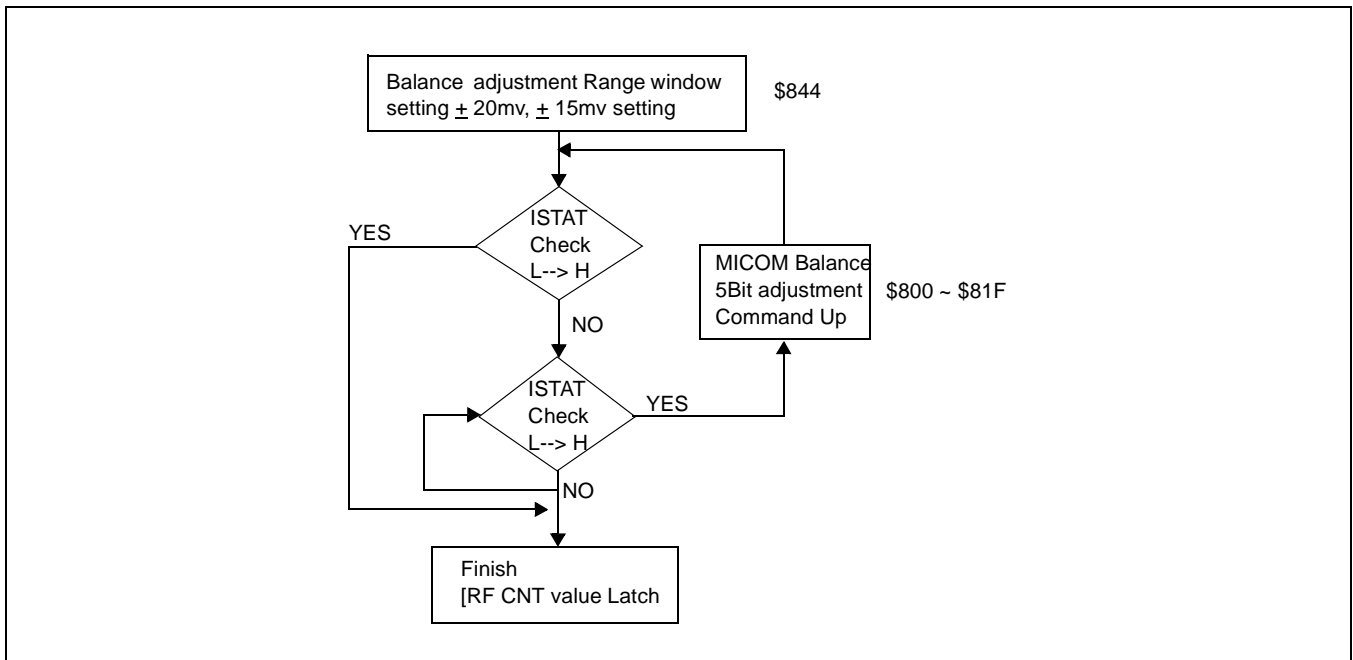

Figure 20. Tracking Balance Adjustment Flow Chart

TRACKING GAIN ADJUSTMENT

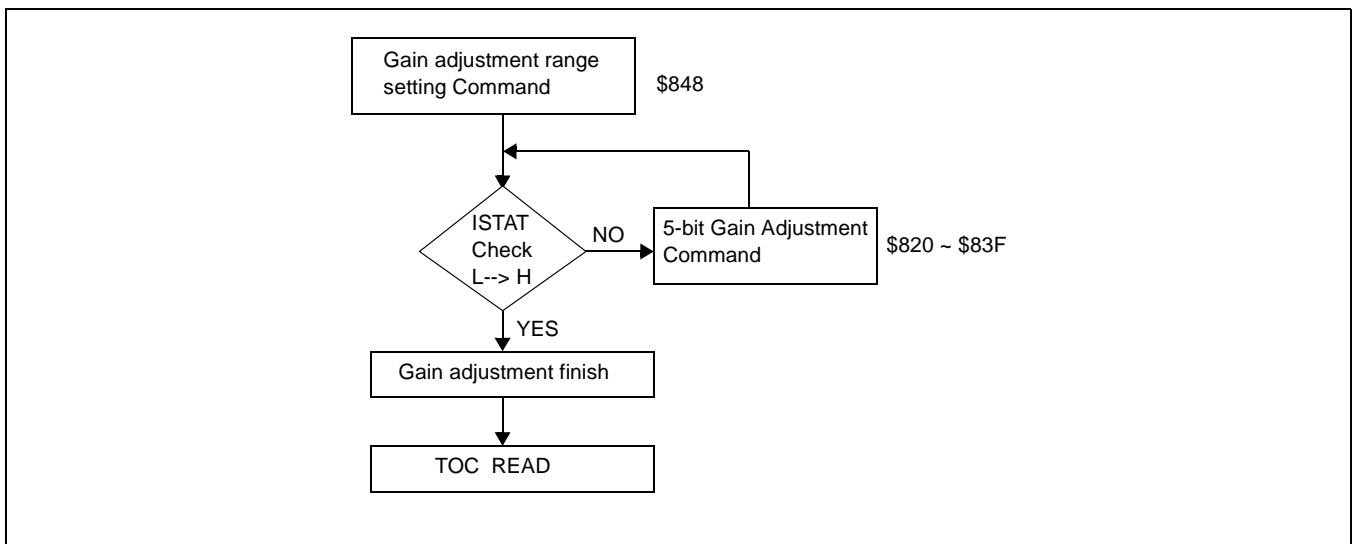
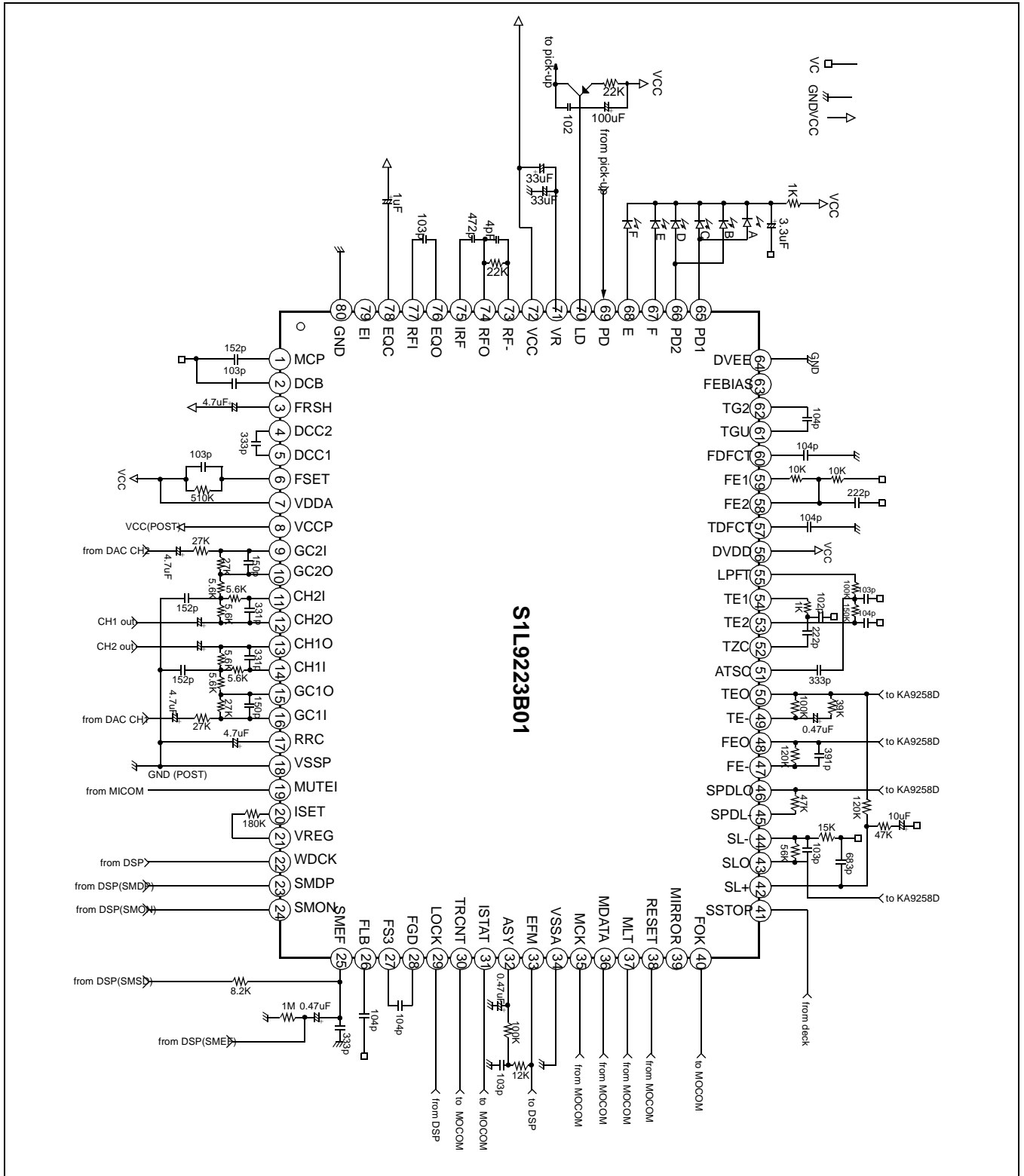

Figure 21. Tracking Gain Adjustment Flow Chart

APPLICATION CIRCUIT



PACKAGE DIMENSION

