

## SPST High Isolation CATV Switch 5 - 1000 MHz

Rev. V1

### Features

- 75 Ohm Impedance
- Positive Voltage Control (0 / +5 V)
- Input Terminated (Off State)
- Low Insertion Loss: 0.62 dB at 870 MHz
- High Isolation: 54 dB at 870 MHz
- 3 mm FQFP-N 12 Lead Package
- 0.5 micron GaAs PHEMT Process

### Description

M/A-COM's MASWSS0067 is a GaAs PHEMT MMIC single pole single throw (SPST) switch in a low cost 3 mm FQFP-N 12 lead package. The MASWSS0067 is ideally suited for applications where low control voltage, low insertion loss, high isolation, small size and low cost are required. Typical applications are to replace mechanical relays in CATV systems. This part can be used in all 75 ohm systems operating up to 1.0 GHz.

The MASWSS0067 is fabricated using a 0.5 micron gate length GaAs PHEMT process. The process features full passivation for performance and reliability.

### Ordering Information <sup>1</sup>

Part Number	Package
MASWSS0067	FQFP-N 12-lead Plastic Package
MASWSS0067TR	7 inch, 1000 piece reel
MASWSS0067TR-3000	13 inch, 3000 piece reel
MASWSS0067SMB	Sample Test Board (Includes 5 Samples)

1. Reference Application Note M513 for reel size information.

### Functional Schematic

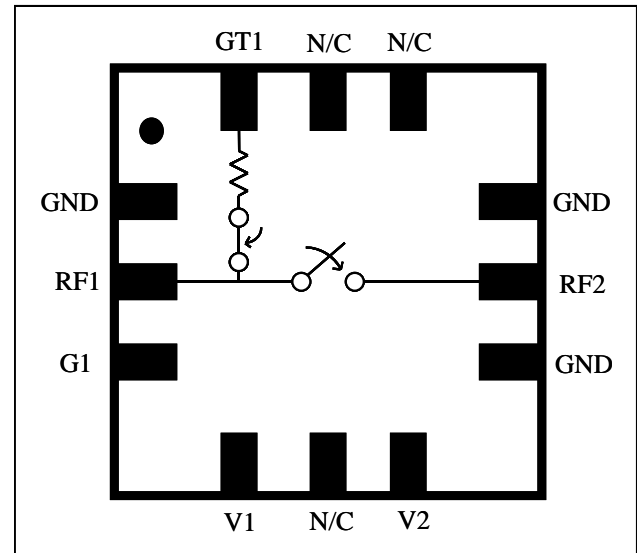

### Pin Configuration <sup>2</sup>

PIN No.	PIN Name	Description
1	GND	Ground
2	RF1	RF In
3	G1	RF Ground
4	V1	Control 1
5	N/C	No Connection
6	V2	Control 2
7	GND	Ground
8	RF2	RF Out
9	GND	Ground
10	N/C	No Connection
11	N/C	No Connection
12	GT1	RF Ground

2. The exposed pad centered on the package bottom must be connected to both RF and DC ground.

## SPST High Isolation CATV Switch 5 - 1000 MHz

Rev. V1

### Electrical Specifications: $T_A = 25^\circ\text{C}$ , $V_C = 0\text{V} / 5\text{V}$ , $Z_0 = 75 \Omega$ <sup>3</sup>

Parameter	Test Conditions	Units	Min.	Typ.	Max.
Insertion Loss	5 - 50 MHz	dB	—	0.45	—
	50 - 1000 MHz	dB	—	0.65	0.9
Isolation	5 - 50 MHz	dB	—	70	—
	50 - 1000 MHz	dB	50	53	—
Return Loss (On)	5 - 50 MHz	dB	—	30	—
	50 - 1000 MHz	dB	—	16	—
Return Loss (Off) (RF1 only)	5 - 50 MHz	dB	—	30	—
	50 - 1000 MHz	dB	—	18	—
IP3	Two Tone, +10 dBm / tone, 6 MHz Spacing, > 50 MHz	dBm	—	52	—
Trise, Tfall	10% to 90% RF, 90% to 10% RF	nS	—	20	—
Ton, Toff	50% control to 90% RF, and 50% control to 10% RF	nS	—	40	—
Transients	In Band	mV	—	30	—
Control Current	$ V_C  = 5\text{V}$	$\mu\text{A}$	—	10	25

3. External DC blocking capacitors are required on all RF ports.

### Absolute Maximum Ratings<sup>4</sup>

Parameter	Absolute Maximum
Max Input Power (5 - 1000 MHz, 2.5V Control)	+32 dBm
Operating Voltage	+8.5 volts
Operating Temperature	-40 °C to +85 °C
Storage Temperature	-65 °C to +150 °C

4. Exceeding any one or combination of these limits may cause permanent damage to this device.

### Truth Table<sup>5</sup>

V1	V2	RF1—RF2
1	0	On
0	1	Off

5. 0 = 0 V  $\pm$  0.2 V; 1 = +2.5 V to +5.0 V.

### Qualification

Qualified to M/A-COM Specification Rel 201, Process Flow -2.

### Handling Procedures

Please observe the following precautions to avoid damage:

### Static Sensitivity

Gallium arsenide integrated circuits are sensitive to electrostatic discharge (ESD) and can be damaged by static electricity. Use proper ESD control precautions when handling these devices.

## Typical Performance Curves

**Insertion Loss vs. Frequency over Temperature**

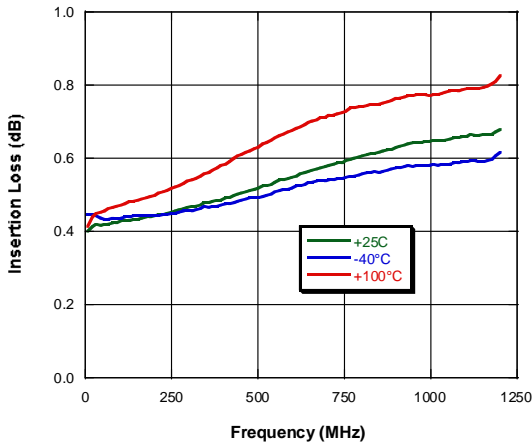

**S11 (Switch On) vs. Frequency over Temperature**

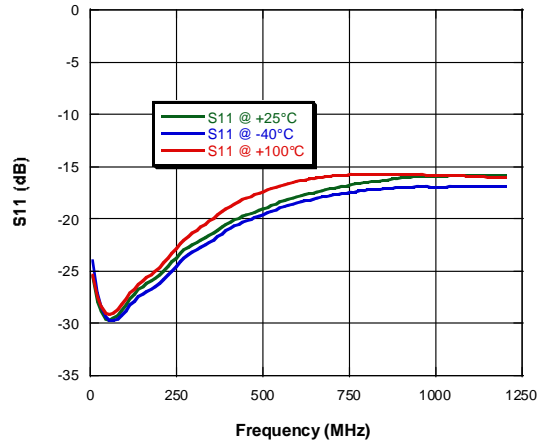

**Isolation vs. Frequency over Temperature**

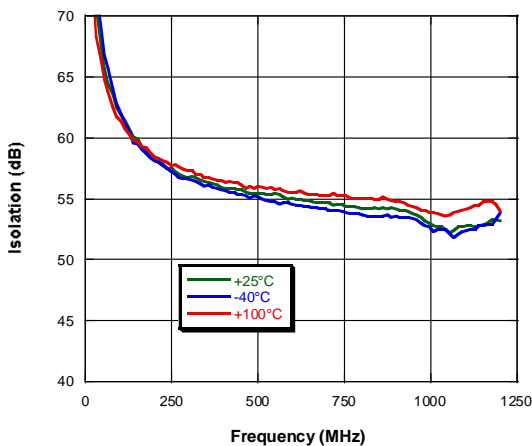

**S11 (Switch Off) vs. Frequency over Temperature**

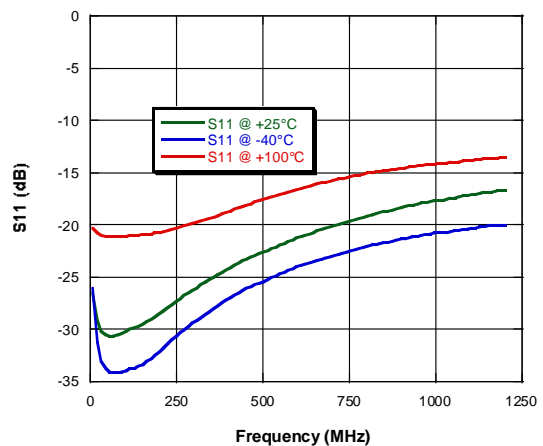

## SPST High Isolation CATV Switch 5 - 1000 MHz

Rev. V1

### 3 mm PQFN 12 Lead

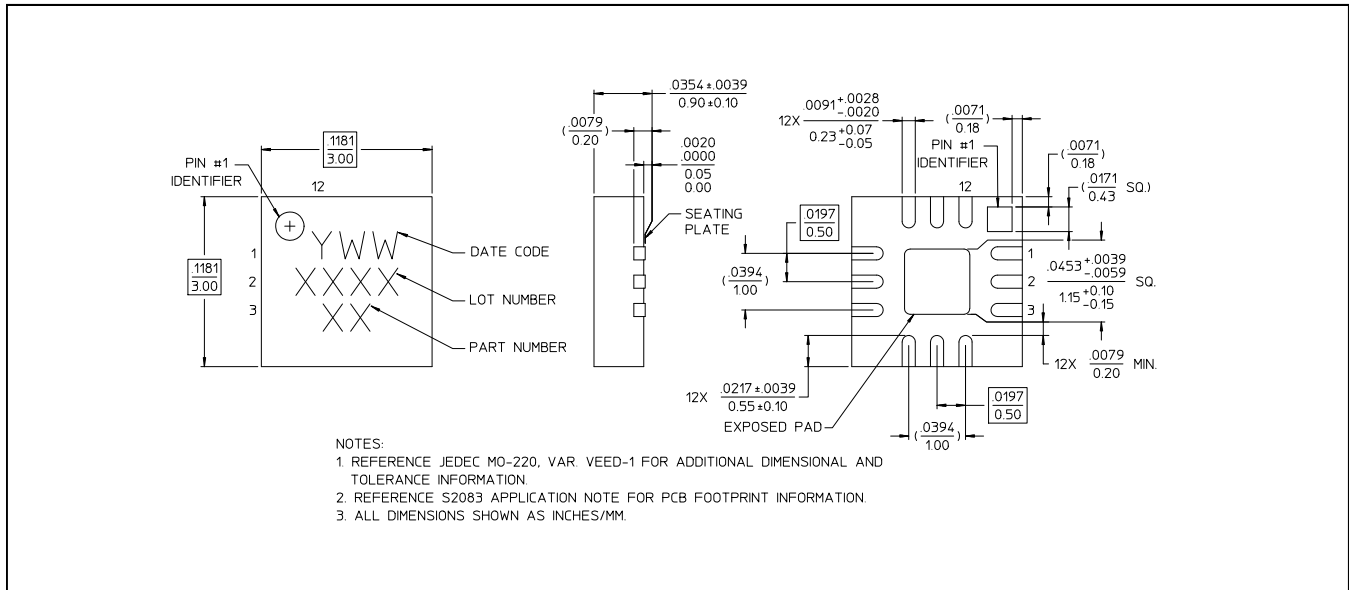

### Application Schematic

