

MS48P25

P-Channel 30-V (D-S) MOSFET

Description

These miniature surface mount MOSFETs utilize a high cell density trench process to provide low $R_{DS(on)}$ and to ensure minimal power loss and heat dissipation. Typical applications are DC-DC converters and power management in portable and battery-powered products such as computers, printers, and PCMCIA cards, cellular and cordless telephones.

Features

- Low $r_{DS(on)}$ provides higher efficiency and extends battery life
- Low thermal impedance copper lead frame SOIC-8 saves board space
- Fast switching speed
- RoHS compliant package

Packing & Order Information

3,000/Reel



**RoHS
COMPLIANT**

Graphic symbol

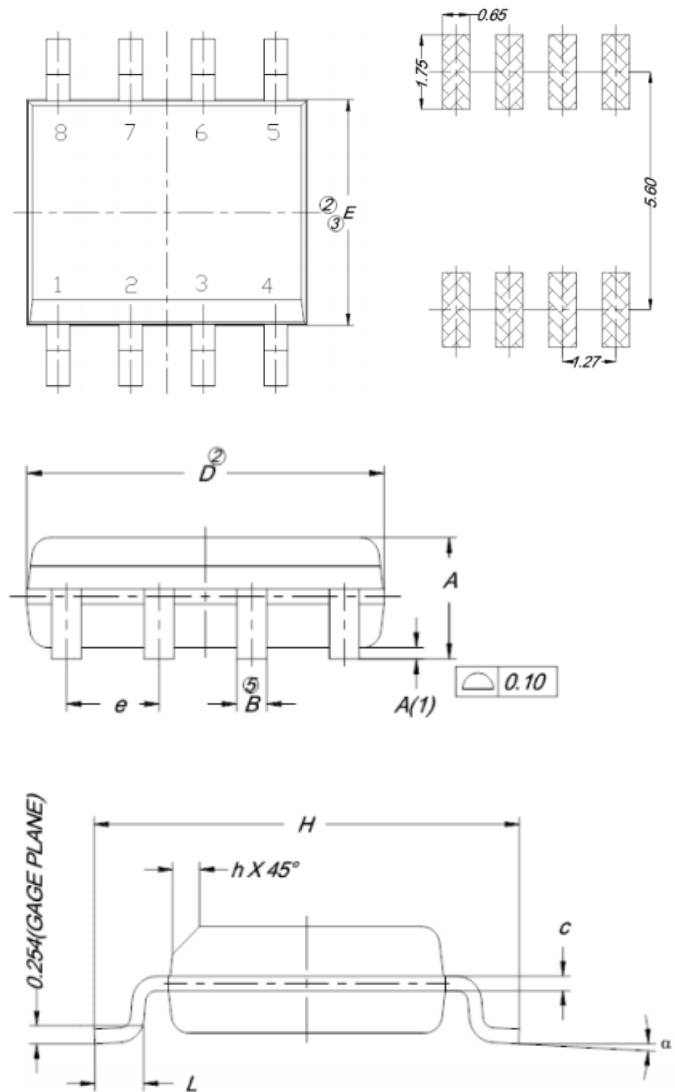
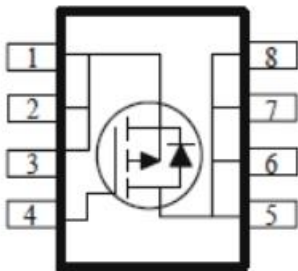

| DIM. | MILLIMETERS | | |
|----------|-------------|------|------|
| | MIN. | NOM. | MAX. |
| A | 1.35 | 1.55 | 1.75 |
| A(1) | 0.10 | 0.18 | 0.25 |
| B | 0.38 | 0.45 | 0.51 |
| C | 0.19 | 0.22 | 0.25 |
| D | 4.80 | 4.90 | 5.00 |
| E | 3.80 | 3.90 | 4.00 |
| e | 1.27 BSC | | |
| H | 5.80 | 6.00 | 6.20 |
| L | 0.50 | 0.72 | 0.93 |
| α | 0° | 4° | 8° |
| h | 0.25 | 0.38 | 0.50 |

MS48P25

P-Channel 30-V (D-S) MOSFET

MAXIMUM RATINGS AND ELECTRICAL CHARACTERISTICS

Absolute Maximum Ratings ($T_A=25^\circ\text{C}$ unless otherwise specified)

| Symbol | Parameter | Value | Unit |
|---------------|--|-------------|------------------|
| V_{DS} | Drain-Source Voltage | -30 | V |
| V_{GS} | Gate-Source Voltage | ± 25 | V |
| I_D | Continuous Drain Current ^a ($T_A=25^\circ\text{C}$) | -11.5 | A |
| | Continuous Drain Current ^a ($T_A=70^\circ\text{C}$) | -9.3 | A |
| I_{DM} | Pulsed Drain Current ^b | -50 | A |
| I_S | Continuous Source Current (Diode Conduction) ^a | ± 4.3 | A |
| P_D | Power Dissipation ^a ($T_A=25^\circ\text{C}$) | 3.1 | W |
| | Power Dissipation ^a ($T_A=70^\circ\text{C}$) | 2.2 | W |
| T_J/T_{STG} | Operating Junction and Storage Temperature | -55 to +150 | $^\circ\text{C}$ |

Thermal characteristics ($T_c=25^\circ\text{C}$ unless otherwise noted)

| Symbol | Parameter | Maximum | Units |
|-----------------|---|---------|--------------------|
| $R_{\theta JA}$ | Maximum Junction-to-Ambient C/W ^a ($t \leq 10$ sec) | 40 | $^\circ\text{C/W}$ |
| | Maximum Junction-to-Ambient C/W ^a (Steady-State) | 80 | |

Notes

- Surface Mounted on 1" x 1" FR4 Board.
- Pulse width limited by maximum junction temperature

Static

| Symbol | Parameter | Test Conditions | Min | Typ. | Max. | Units |
|--------------|---------------------------------|--|-------|------|-----------|---------------|
| $V_{GS(th)}$ | Gate-Source Threshold Voltage | $V_{DS} = V_{GS}$, $I_D = -250\mu\text{A}$ | -1.0 | | | V |
| I_{GSS} | Gate-Body Leakage | $V_{DS} = 0$ V, $V_{GS} = \pm 25$ V | | | ± 100 | nA |
| I_{DSS} | Zero Gate Voltage Drain Current | $V_{DS} = -24$ V, $V_{GS} = 0$ V $V_{DS} = -24$ V, $V_{GS} = 0$ V, $T_J = 55^\circ\text{C}$ | | | -1 -25 | μA |
| $I_{D(on)}$ | On-State Drain Current | $V_{DS} = 5$ V, $V_{GS} = 10$ V | -5.75 | | | A |
| $I_{DS(on)}$ | Drain-Source On-Resistance | $V_{DS} = 10$ V, $I_D = -9.2$ A $V_{DS} = -4.5$ V, $I_D = -7.5$ A | | | 13 19 | m Ω |
| g_{fs} | Forward Transconductance | $V_{GS} = -15$ V, $I_D = -9.2$ A | | 40 | | S |
| V_{SD} | Diode Forward Voltage | $I_S = -2.2$ A, $V_{GS} = 0$ V | | -0.7 | | V |

Dynamic

| Symbol | Parameter | Test Conditions | Min | Typ. | Max. | Units |
|----------|--------------------|--|-----|------|------|-------|
| Q_g | Total Gate Charge | $V_{DS} = -15$ V, $I_D = -9.2$ A, $V_{GS} = -4.5$ V | -- | 42 | -- | nC |
| Q_{gs} | Gate-Source Charge | | -- | 13 | -- | nC |
| Q_{gd} | Gate-Drain Charge | | -- | 20 | -- | nC |

MS48P25

P-Channel 30-V (D-S) MOSFET

| Dynamic | | | | | | |
|--------------|------------------------------|---|-----|------|------|-------|
| Symbol | Parameter | Test Conditions | Min | Typ. | Max. | Units |
| $t_{d(on)}$ | Turn-On Delay Time | $I_D = -9.2 \text{ A}$, $R_L = 1.7 \Omega$, $V_{GEN} = -10 \text{ V}$, $R_{GEN} = 6 \Omega$ $V_{DS} = -15 \text{ V}$ | -- | 9 | -- | ns |
| t_r | Rise Time | | -- | 48 | -- | ns |
| $t_{d(off)}$ | Turn-Off Delay Time | | -- | 104 | -- | ns |
| t_f | Fall Time | | -- | 59 | -- | ns |
| C_{ISS} | Input Capacitance | $V_{DS} = -15 \text{ V}$ $f = 1 \text{ MHz}$, $V_{GS} = 0 \text{ V}$ | -- | 2380 | -- | pF |
| C_{OSS} | Output Capacitance | | -- | 369 | -- | pF |
| C_{RSS} | Reverse Transfer Capacitance | | -- | 350 | -- | pF |

Notes

- Pulse test: $PW \leq 300\mu s$ duty cycle $\leq 2\%$.
- Guaranteed by design, not subject to production testing.

MS48P25

P-Channel 30-V (D-S) MOSFET

Typical Electrical Characteristics

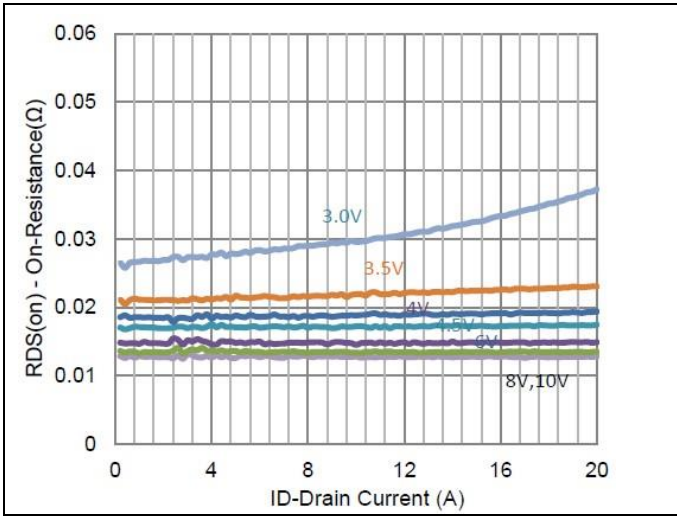

FIG.1-ON REGION CHARACTERISTICS

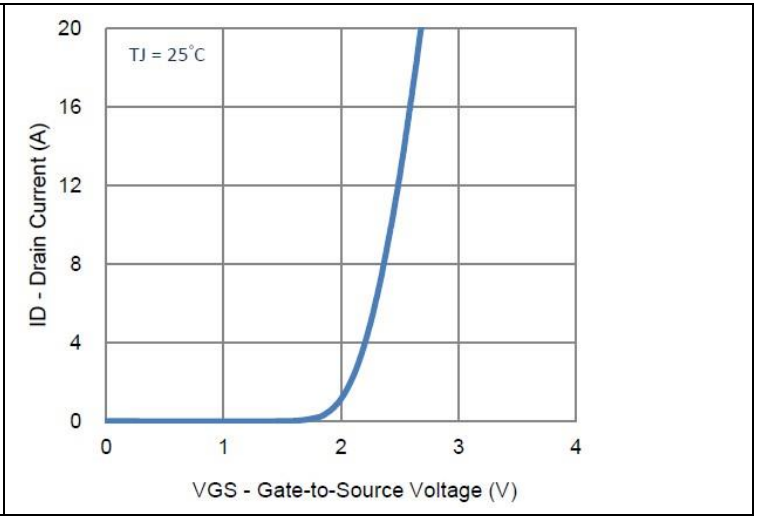

FIG.2-TRANSFER CHARACTERISTICS

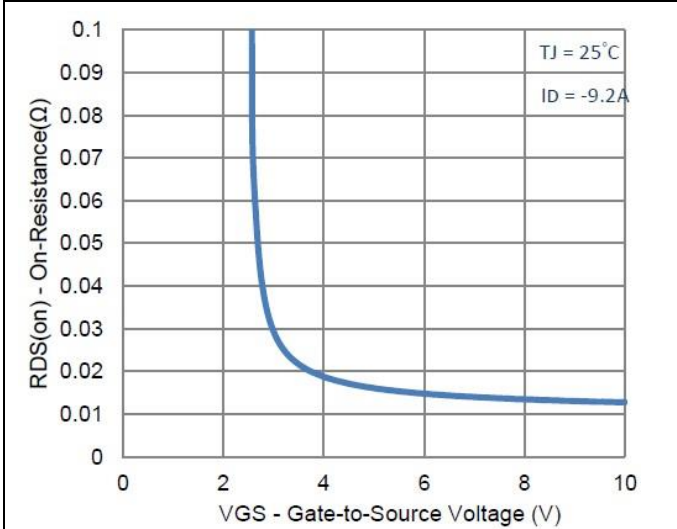

FIG.3-ON RESISTANCE VARIATION VS DRAIN CURRENT AND GATE VOLTAGE

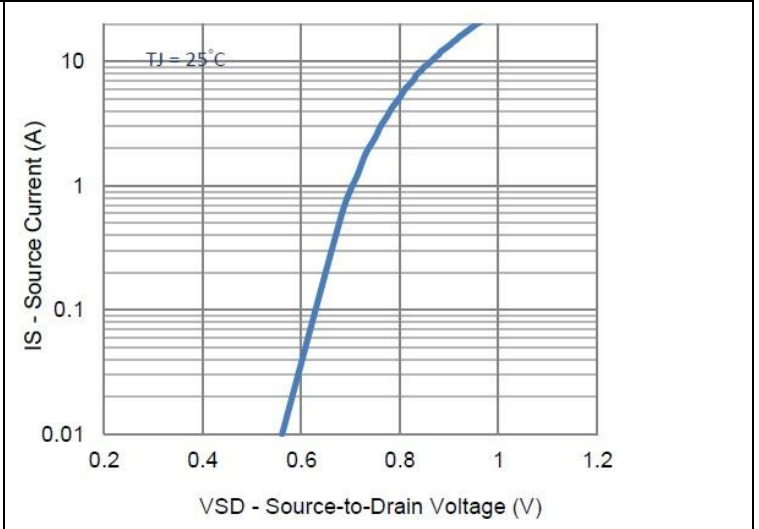

FIG.4-BODY DIODE FORWARD VOLTAGE VARIATION WITH SOURCE CURRENT AND TEMPERATURE

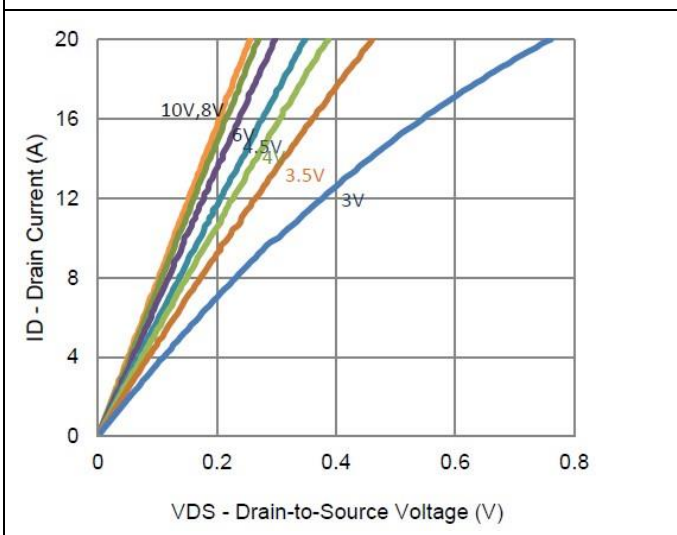

FIG.5-CAPACITANCE CHARACTERISTICS

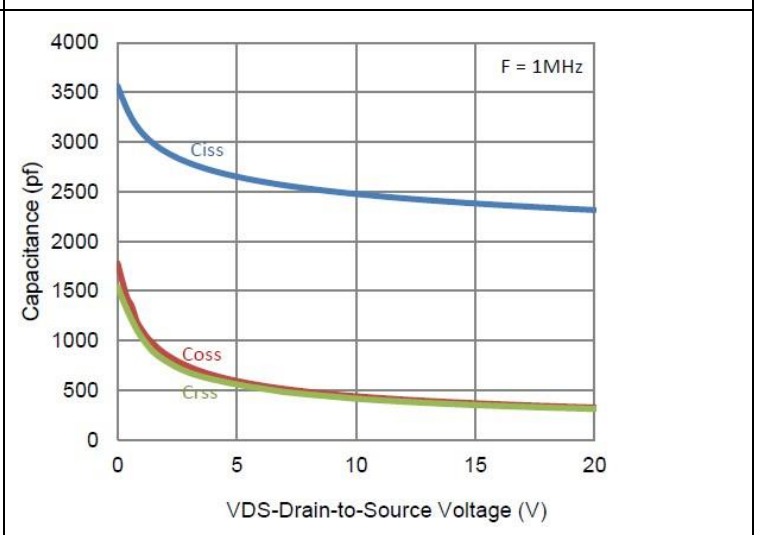

FIG.6-GATE CHARGE CHARACTERISTICS

MS48P25

P-Channel 30-V (D-S) MOSFET

MS48P25

P-Channel 30-V (D-S) MOSFET

■ Typical Electrical Characteristics

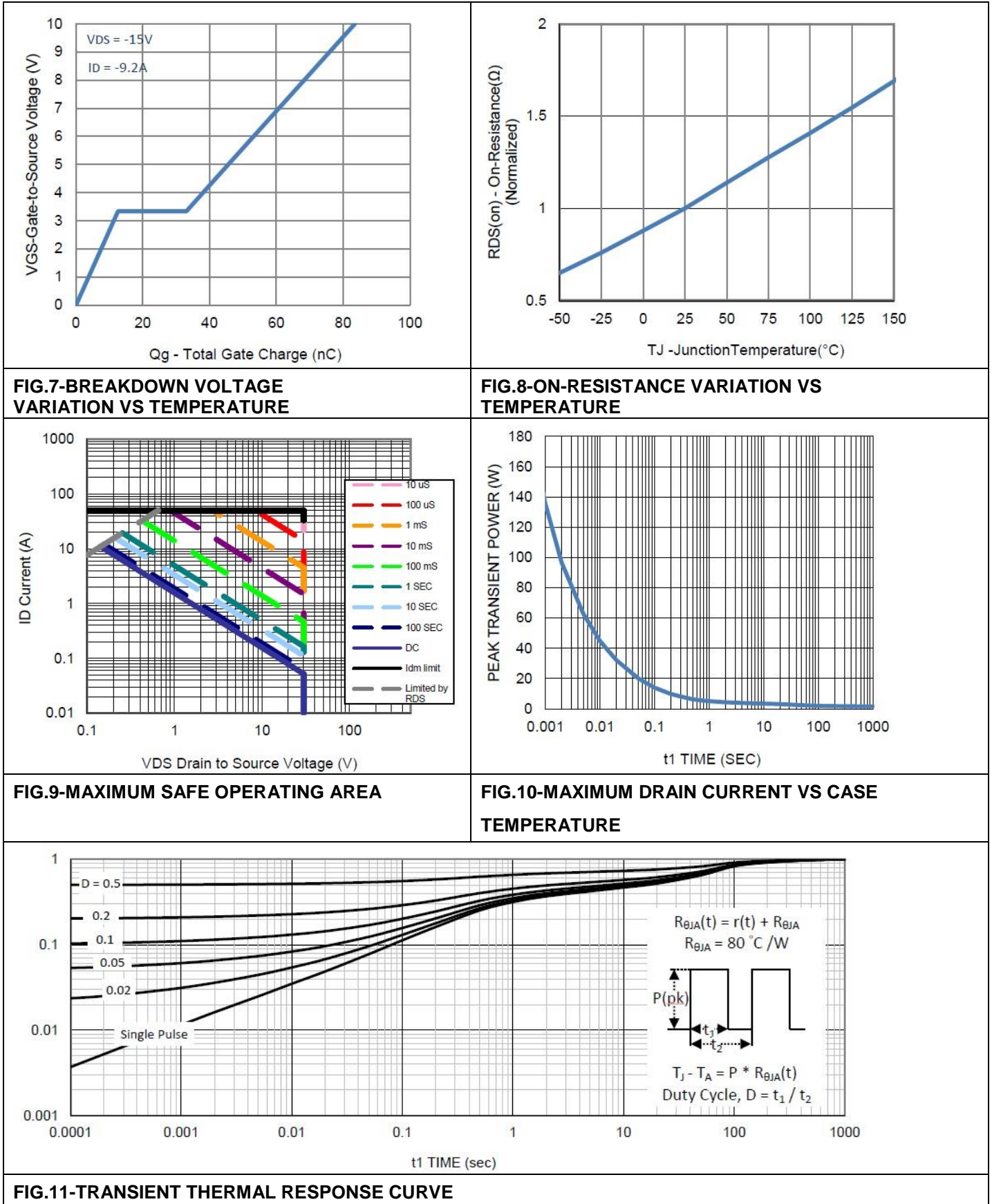

MS48P25

P-Channel 30-V (D-S) MOSFET

Disclaimer

ALL PRODUCT, PRODUCT SPECIFICATIONS AND DATA ARE SUBJECT TO CHANGE WITHOUT NOTICE TO IMPROVE RELIABILITY, FUNCTION OR DESIGN OR OTHERWISE.

Bruckewell Technology Inc., its affiliates, agents, and employees, and all persons acting on its or their behalf (collectively, "Bruckewell"), disclaim any and all liability for any errors, inaccuracies or incompleteness contained in any datasheet or in any other disclosure relating to any product.

Bruckewell makes no warranty, representation or guarantee regarding the suitability of the products for any particular purpose or the continuing production of any product. To the maximum extent permitted by applicable law, Bruckewell disclaims

- (i) Any and all liability arising out of the application or use of any product.
- (ii) Any and all liability, including without limitation special, consequential or incidental damages.
- (iii) Any and all implied warranties, including warranties of fitness for particular purpose, non-infringement and merchantability.

Statements regarding the suitability of products for certain types of applications are based on Bruckewell's knowledge of typical requirements that are often placed on Bruckewell products in generic applications.

Such statements are not binding statements about the suitability of products for a particular application. It is the customer's responsibility to validate that a particular product with the properties described in the product specification is suitable for use in a particular application. Parameters provided in datasheets and/or specifications may vary in different applications and performance may vary over time.

Product specifications do not expand or otherwise modify Bruckewell's terms and conditions of purchase, including but not limited to the warranty expressed therein.