

Figure 1

1. INTRODUCTION

This instruction sheet covers application, inspection and maintenance procedures for Hydraulic Crimping Head PN 1752786-1 shown in Figure 1.

The crimping head accepts interchangeable die sets for a variety of terminals and splices for large wire sizes - 4/0 through 1000 MCM range. Refer to the instructions packaged with the specific die sets for compatible products, wire ranges, strip dimensions, and application procedures.

This crimping head is designed for use with Foot Hydraulic Pump PN 1583659-1, Hand Hydraulic Pump PN 1583661-1, or Electric Hydraulic Pumps; PN 1804700-1 (115 VAC) and PN 1804700-2 (220 VAC).

Warning: To avoid personal injury and potential damage to the crimp head, TE Connectivity (TE) requires the crimp head to operate at 9,800 to 10,200 PSI [676 to 703 bar]. TE recommends using 10,000 PSI [689 bar] TE Hydraulic Pumps as other manufacturers' pumps may apply insufficient pressure (resulting in an inadequate crimp) or excessive pressure (resulting in failure of the head). Additionally, the TE pump must be used to maintain CE certification; if using other manufacturers' pumps, the user is responsible for self-certification.

Read these instructions, and all applicable references before inserting any die set assemblies and crimping any terminals or splices.



NOTE

Dimensions in this instruction sheet are in millimeters [with inches in brackets]. Illustrations and figures are for reference only and are not drawn to scale.

Reasons for reissue of this Instruction Sheet are provided in Section 9; REVISION SUMMARY

2. DESCRIPTION

Main components of this crimping head include a “C”-Head, which houses the stationary die, a cylinder which contains the hydraulic chamber, a piston (ram) which holds and controls the moving die, and a quick-disconnect coupling (cylinder half) which mates with the coupling on the hose to release or supply pressure. A dust cap covers the quick-disconnect coupling.

3. CRIMPING HEAD INSTALLATION



DANGER

Verify that the hydraulic pressure to hose or handle control is released and that power supply is disconnected from electric power unit, if applicable.



CAUTION

Prior to installing the head, verify that the pump and hose being used are working properly, and are adjusted to and rated at 68948 kPa [10,000 psi]. An incorrectly adjusted or rated pump/hose could result in severe tooling damage, as well as personal injury.

1. Remove protective dust caps from both quick connect/disconnect couplers.
2. Thoroughly clean the coupling on the pump/hose and the coupling on the crimping head.
3. Mate both quick-disconnect couplers and tighten the collar of the coupler assembly on the crimping head (see Figure 1).



CAUTION

Oil flow must be unobstructed between power unit and crimping head. Verify that all couplers are fully mated and tightened.



NOTE

If crimping head must be removed after being in production, pressure must be released in the hydraulic system before head is removed. If using Electric Hydraulic Power Unit-1804700-1 or 2, disconnect power unit from power supply. When using Hydraulic Foot Pump PN 1583659-1 or Hydraulic Hand Pump PN 1583661-1, depress the pressure release pedal to release pressure.

4. DIE INSTALLATION AND REMOVAL (FIGURE 2)



DANGER

To avoid personal injury, avoid accidentally depressing foot switch or handle control of power unit when changing dies.



CAUTION

Operating the crimping head WITHOUT the dies installed will damage the “C”-Head or ram.

A. Installation

1. Back out the set screws in the crimping head and ram (the ram must be raised slightly to gain access to the set screw).
2. Insert the dies into the crimping head and the ram, ensuring the “flats” of the die shanks are facing the set screws. Tighten the set screws.
3. Activate the power unit and slowly close the dies to verify proper alignment.
4. Complete the cycle and allow the ram to return to the “DOWN” position.

B. Removal



DANGER

To avoid personal injury, avoid accidentally depressing foot switch or handle control of power unit when changing dies.



CAUTION

Operating the crimping head WITHOUT the dies installed will damage the “C”-Head or ram.

1. Back out the set screw in the crimping head and remove the stationary die.
2. Raise the ram enough to expose the set screw and back it out until the moving die can be removed.

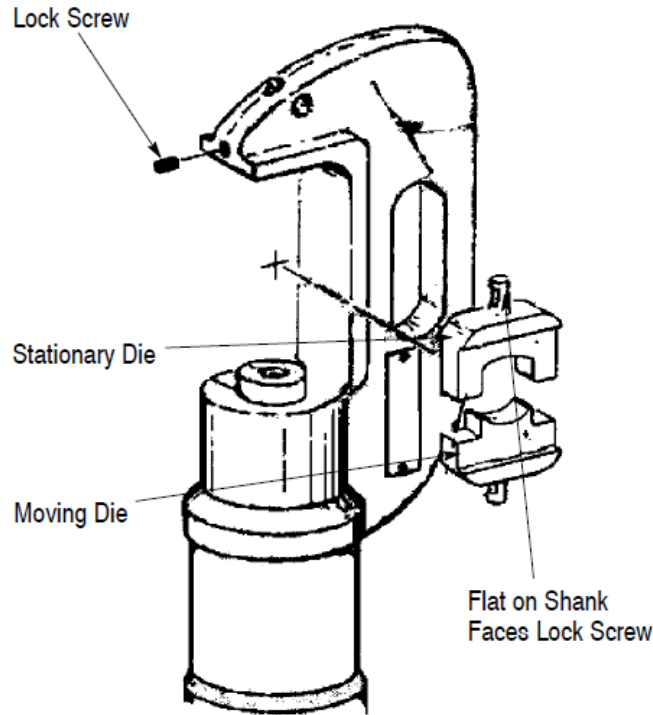

Figure 2

5. CRIMPING PROCEDURE

The following procedure provides only general information concerning crimping. Refer to instructional material packaged with the dies and power unit for more detailed information including wire stripping dimensions and how to position terminals or splices in the dies.



CAUTION

Never operate the power unit without having a crimping head attached to the handle control or crimping head coupling.

1. Insert a terminal or splice in the stationary die in accordance with instructions packaged with the dies.
2. Activate the power unit to advance the dies and hold terminal or splice in place.
3. Insert the stripped wire into the terminal or splice.
4. Activate the power unit to complete the crimp.

6. INSPECTION AND MAINTENANCE



DANGER

Verify hydraulic pressure is released and power supply is disconnected before following inspection and maintenance procedures, unless otherwise specified in the procedure.

Each crimping head is assembled and inspected before shipment. TE Connectivity recommends that the crimping head be inspected immediately upon its arrival at the facility of use, and at regularly scheduled intervals to ensure the head has not been damaged during handling and use. Frequency of inspection depends upon the following: care, amount of use, and handling of the head; type and size of products crimped; degree of operator skill; and environmental conditions.

6.1. Visual Inspection

Refer to Figures 3 and 5; proceed as follows:

1. Inspect the assembled crimping head for nicks, scratches, cracks, and excessive wear, especially where sliding contact occurs.
2. Inspect for cracks particularly at the corners of the "C"-Head and around the top of the cylinder.



NOTE

Once per year, or every 7,500 cycles (whichever comes first), the hydraulic head should be returned to TE for magnetic particle inspection. Additionally, inspect and service the head every month or 1,000 cycles.

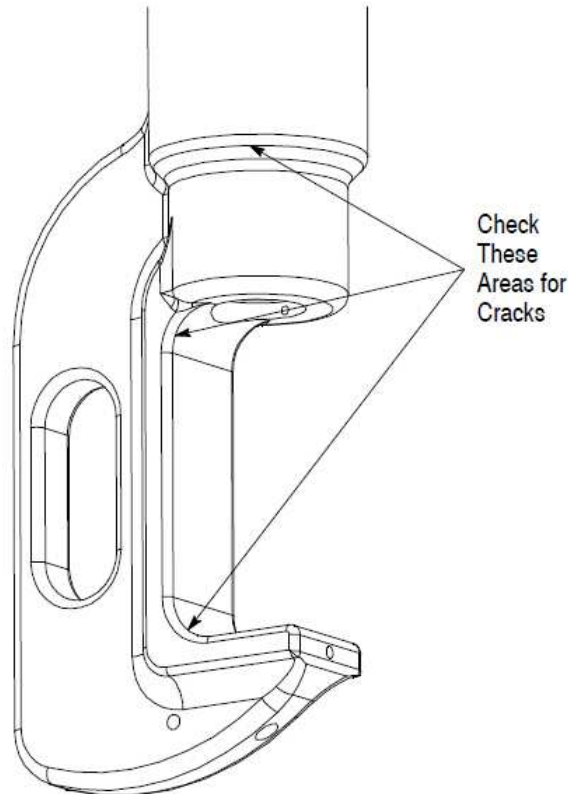

Figure 3

6.2. Cleaning

1. Remove accumulations of dirt and grease on the crimping head; especially in areas where dies are installed and terminals are crimped.
2. Clean the entire head frequently with a clean, lint-free cloth.

6.3. Crimping Head Check-Out Procedure

If the ram fails to retract after completion of a crimping cycle, the cause may be in the crimping head. To determine whether the trouble is in the crimping head or not, release pressure in the power unit.

If the ram retracts, the trouble is not in the crimping head.

If ram does not retract, refer to paragraph 7. REPLACEMENT and REPAIR

7. REPLACEMENT AND REPAIR

Customer-replaceable parts are listed in Figure 4. A complete inventory should be stocked and controlled to prevent lost time when replacement of parts is necessary. Order parts through your TE representative or call 1-800-526-5142, or send a facsimile of your purchase order to 1-717-986-7605, or write, or return the entire tool for evaluation and repair, with a written description of the problem to:

CUSTOMER SERVICE (38-35)
 TE CONNECTIVITY CORPORATION
 P.O. BOX 3608
 HARRISBURG, PA 17105-3608

Tools may also be returned for evaluation and repair. For tool repair service, contact a TE representative at 1-800-526-5136.

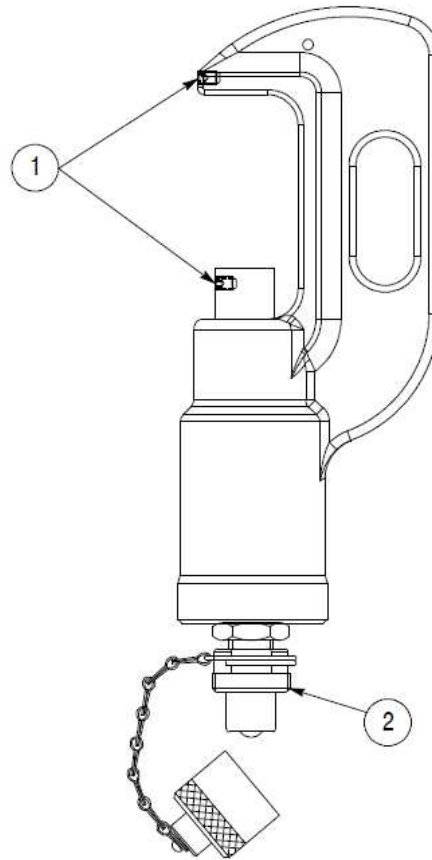

Item Number	Part Number	Description	Quantity Per Head
1	21013-4	Screw, Socket Head, Self-Locking, 1/4-20 UNC x 9.52 mm [.375 in] Long	2
2	311470-1	Coupler, Quick-Disconnect, Cylinder Half	1

Figure 4

8. TROUBLESHOOTING

Part	Inspection and Problem	Possible Solution
"C"-Head	Inspect for cracks, gouges, nicks, or galling on the "C"-Head or where the "C"-Head contacts dies	Return tool for repair (see Section 7)
	Check to see if the upper die retaining pin does not hold the stationary die in place	Return tool for repair (see Section 7)
	Check to see if the upper die release button sticks (it should normally move in and out easily when moderate pressure is applied)	Return tool for repair (see Section 7)
Cylinder	Inspect for evidence of cracks, gouges, nicks, or galling	If there are cracks, return the tool for repair (see Section 7)
		For traces of gouges, nicks, or galling: remove any sharp edges using a fine emery cloth
	Inspect for oil leaks between the cylinder and coupling	For oil leaks and a sticky coupling, tighten or replace the coupling
	Check to see if the coupling sticks to the cylinder (it should normally turn on and off freely when moderate pressure is applied with a wrench)	
Quick-Disconnect Coupling	The coupling mates hard or will not mate or release, or it leaks oil, or it sticks at the hose connection	Replace coupling
Ram	Inspect the ram in the Power "ON" (ram advanced) position for evidence of galling, cracks, or oil leaks between the ram and the cylinder	If there are cracks or leaks, return the tool for repair (see Section 7)
		If there is galling, remove any sharp edges using a fine emery cloth
	Check to see if the lower die retaining pin does not hold the moving die in place	Return tool for repair (see Section 7)
	Check to see if the lower die release button sticks (it should normally move in and out easily when moderate pressure is applied)	Return tool for repair (see Section 7)
	Inspect the ram in the Power "OFF" (ram retracted) position to ensure that the ram returns freely to its original position	Return tool for repair (see Section 7)

Figure 5

9. REVISION SUMMARY

- ◆ Latest TE logo and formatting resulting in numbering changes of some paragraphs
- ◆ Added Warning (paragraph 1)
- ◆ Moved info on magnetic particle inspection from previous paragraph 5 to new paragraph 6.1.as a NOTE
- ◆ Added Section 8 TROUBLESHOOTING and Figure 5