

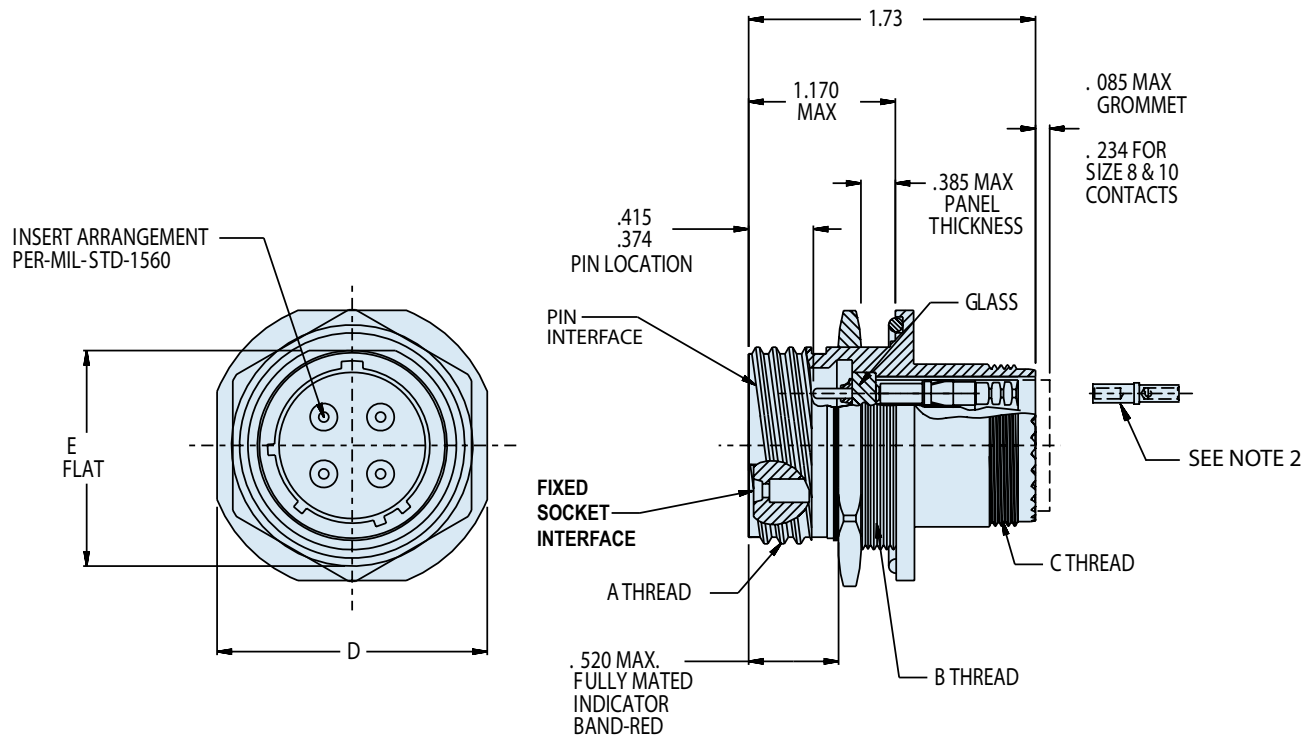

257-216
Jam Nut Mount Hermetic Receptacles
with Crimp Removable Socket Contacts
MIL-DTL-38999 Series III Type

B

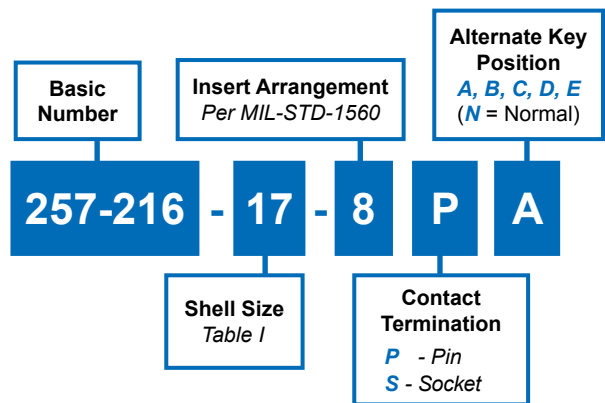

Dimensions in Inches (millimeters) are subject to change without notice.

257-216

**Jam Nut Mount Hermetic Receptacles
with Crimp Removable Socket Contacts
MIL-DTL-38999 Series III Type**



MIL-DTL-38999 Type
Hermetic Connectors

B

TABLE I: CONNECTOR DIMENSIONS

SHELL SIZE	CODE	A THREAD 0.1 P-0.3L-TS-2A	B THREAD	C THREAD	D ± .016	E +.004 (0.1) -.006 (0.15)	F DIA ± .005 (0.1)
9	A	0.625	M17X1-6g 0.100R	M12X1-6g 0.100R	1.062	.657 (16.70)	.693 (17.60)
11	B	0.750	M20X1-6g 0.100R	M15X1-6g 0.100R	1.252	.771 (19.59)	.825 (20.96)
13	C	0.875	M25X1-6g 0.100R	M18X1-6g 0.100R	1.374	.955 (24.26)	1.010 (25.65)
15	D	1.000	M28X1-6g 0.100R	M22X1-6g 0.100R	1.500	1.085 (27.56)	1.135 (28.83)
17	E	1.187	M32X1-6g 0.100R	M25X1-6g 0.100R	1.626	1.210 (30.73)	1.260 (32.01)
19	F	1.250	M35X1-6g 0.100R	M28X1-6g 0.100R	1.811	1.335 (33.91)	1.385 (35.18)
21	G	1.375	M38X1-6g 0.100R	M31X1-6g 0.100R	1.937	1.460 (37.08)	1.510 (38.35)
23	H	1.500	M41X1-6g 0.100R	M34X1-6g 0.100R	2.063	1.585 (40.26)	1.635 (41.53)
25	J	1.625	M44X1-6g 0.100R	M37X1-6g 0.100R	2.190	1.710 (43.43)	1.760 (44.70)

HERMETIC LEAK RATE MOD CODES	
Designator	Required Leak Rate
-585A	1 x 10 ⁻¹⁰ cc Helium per second
-585B	1 x 10 ⁻⁹ cc Helium per second
-585C	1 x 10 ⁻⁸ cc Helium per second

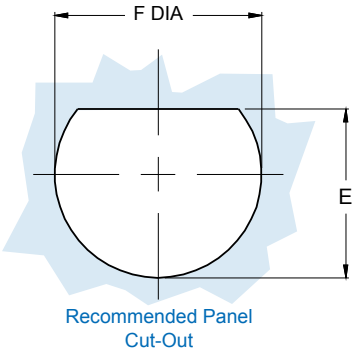

APPLICATION NOTES

- Assembly identified with manufacturer's name and PN, space permitting.
Material/Finish:
Shell, lock ring, jam nut—CRES/passivated
Contacts—alloy 52/gold plate
Sockets—copper alloy/gold plate
Hermetic Insulator—fused vitreous glass/N.A.
Socket Insulator—high grade rigid dielectric/N.A.
Seals—fluorosilicone/ N.A.
Hermeticity—1x10⁻⁷ cc/second
- Crimp removable socket contacts to conform to AS39029/57-359 size 12, MIL-C-39029/57-358, size 16, MIL-C-39029/57-357 size 20 and MIL-C-39029/57-354 size 22D (supplied loose)
- Metric dimensions (mm) are indicated in parentheses.

Dimensions in Inches (millimeters) are subject to change without notice.