



Is Now Part of



ON Semiconductor®

To learn more about ON Semiconductor, please visit our website at
www.onsemi.com

Please note: As part of the Fairchild Semiconductor integration, some of the Fairchild orderable part numbers will need to change in order to meet ON Semiconductor's system requirements. Since the ON Semiconductor product management systems do not have the ability to manage part nomenclature that utilizes an underscore (_), the underscore (_) in the Fairchild part numbers will be changed to a dash (-). This document may contain device numbers with an underscore (_). Please check the ON Semiconductor website to verify the updated device numbers. The most current and up-to-date ordering information can be found at www.onsemi.com. Please email any questions regarding the system integration to Fairchild_questions@onsemi.com.

ON Semiconductor and the ON Semiconductor logo are trademarks of Semiconductor Components Industries, LLC dba ON Semiconductor or its subsidiaries in the United States and/or other countries. ON Semiconductor owns the rights to a number of patents, trademarks, copyrights, trade secrets, and other intellectual property. A listing of ON Semiconductor's product/patent coverage may be accessed at www.onsemi.com/site/pdf/Patent-Marking.pdf. ON Semiconductor reserves the right to make changes without further notice to any products herein. ON Semiconductor makes no warranty, representation or guarantee regarding the suitability of its products for any particular purpose, nor does ON Semiconductor assume any liability arising out of the application or use of any product or circuit, and specifically disclaims any and all liability, including without limitation special, consequential or incidental damages. Buyer is responsible for its products and applications using ON Semiconductor products, including compliance with all laws, regulations and safety requirements or standards, regardless of any support or applications information provided by ON Semiconductor. "Typical" parameters which may be provided in ON Semiconductor data sheets and/or specifications can and do vary in different applications and actual performance may vary over time. All operating parameters, including "Typicals" must be validated for each customer application by customer's technical experts. ON Semiconductor does not convey any license under its patent rights nor the rights of others. ON Semiconductor products are not designed, intended, or authorized for use as a critical component in life support systems or any FDA Class 3 medical devices or medical devices with a same or similar classification in a foreign jurisdiction or any devices intended for implantation in the human body. Should Buyer purchase or use ON Semiconductor products for any such unintended or unauthorized application, Buyer shall indemnify and hold ON Semiconductor and its officers, employees, subsidiaries, affiliates, and distributors harmless against all claims, costs, damages, and expenses, and reasonable attorney fees arising out of, directly or indirectly, any claim of personal injury or death associated with such unintended or unauthorized use, even if such claim alleges that ON Semiconductor was negligent regarding the design or manufacture of the part. ON Semiconductor is an Equal Opportunity/Affirmative Action Employer. This literature is subject to all applicable copyright laws and is not for resale in any manner.

FSA806 — USB2.0 High-Speed (480Mbps), UART, and Audio Switch with Negative Signal Capability

Features

- 3:1 Switch Handles:
 - Audio Headsets
 - UART
 - Up to Two High- and Low-Speed USB Data
- Negative-Swing-Capable Audio Channel
- Built-in Termination Resistors for Audio Pop Reduction
- Simple Switch Control Using Two Select Pins

Description

The FSA806 is a 3:1 USB accessory switch that enables USB data, stereo and mono audio, and UART data to share a common connector port. Two ports are designed for high-speed USB 2.0 signaling, while also capable of full speed USB and UART communication. The architecture is designed to allow audio signals to swing below ground so a common USB and headphone jack can be used for personal media players and portable peripheral devices.

The FSA806 meets both USB Rev. 2.0 and micro-USB specifications.

Applications

- Cell Phones, MP3 Players, PDAs

Ordering Information

Part Number	Operating Temperature Range	Top Mark	Package
FSA806UMX	-40 to +85°C	KN	12-Lead Quad, 1.8 x 1.8mm Ultrathin Molded Leadless Package (UMLP)

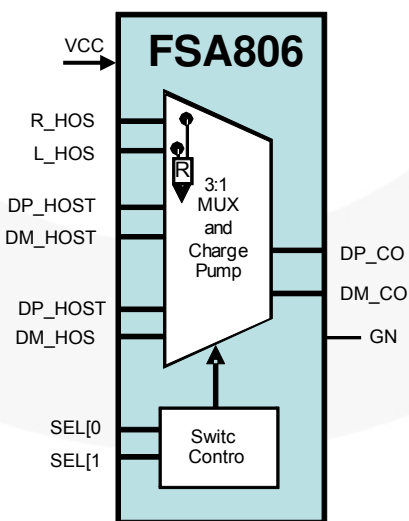

Figure 1. Functional Block Diagram

Application Diagram

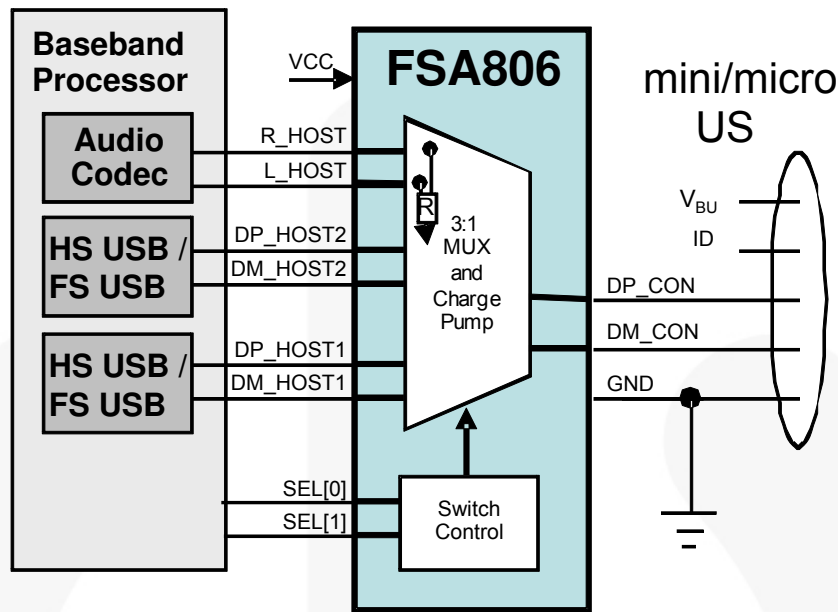

Figure 2. Typical Application

Functional Description

The FSA806 USB2.0 accessory switch is designed to consolidate wired accessories for portable devices, such as cellular telephones and portable audio players. The benefits of consolidation include reduced space requirements from a reduction of connectors and their size. The micro-USB connector, for example, reduces connector height and depth, allowing for slimmer overall designs. Using the USB industry standard and a common connector type, for accessories such as chargers and headsets, greatly reduces the waste associated with new phone purchases by allowing re-use of the accessories.

Using just five wires for all connection types considerably reduces the cost of wired accessories and simplifies their construction. The FSA806 facilitates adopting this methodology because it is designed to redirect the DP/DM pins from the USB connector to one of three ports at the baseband's discretion.

Applications with Multiple USB Controllers

When operating with two USB controllers, it is recommended to configure the switches to OPEN before switching to the other (second) USB interface. The OPEN setting duration should be long enough for the accessory to go to a SE0 state, when the switch is set to the other (second) USB port, the new controller re-enumerates.

Mode Descriptions

The FSA806 select pins control the switching operations, SEL[0] and SEL[1] described in Table 1

Table 1. Selection Truth Table

SEL[1]	SEL[0]	Switch Action	Description
0	0	OPEN	Open all switch paths (device in low-power mode)
0	1	USB1, UART	Closes USB1 path to D+/D-, default condition ⁽¹⁾ - DP_CON connected to DP_HOST1 - DM_CON connected to DM_HOST1
1	0	USB2, UART	Closes USB2 path to D+/D- - DP_CON connected to DP_HOST2 - DM_CON connected to DM_HOST2
1	1	AUDIO	Closes audio path to D+/D- only - DP_CON connected to R_HOST - DM_CON connected to L_HOST

Notes:

1. The SELECT pins are CMOS inputs and should not be left in a floating condition. Some applications require a UART path be in the CLOSED position on power-up for initial programming of the device under test. If that condition is desired, the two SELECT pins should be pulled to the correct levels with external resistors that should exceed 100K Ω to reduce the static power consumption. In other applications, adding weak pull-down resistors to GND defaults the device to all paths open (low-power mode).
2. When the audio switch is in the OPEN position, the R and L are terminated to GND with internal termination resistors to discharge any stray capacitance that could cause audio pop.

Pin Configuration

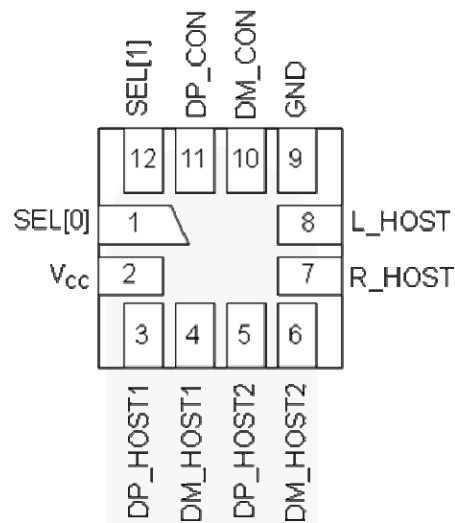

Figure 3. 12-Pin, UMLP Pin Assignments (Top-Through View)

Pin Descriptions

Name	Pin #	Description
USB, UART Interface		
DP_HOST1	3	D+ signal, dedicated USB port to be connected to the resident USB or UART transceiver on the phone.
DM_HOST1	4	D- signal, dedicated USB port to be connected to the resident USB or UART transceiver on the phone.
DP_HOST2	5	D+ signal, dedicated USB port to be connected to the resident USB or UART transceiver on the phone.
DM_HOST2	6	D- signal, dedicated USB port to be connected to the resident USB or UART transceiver on the phone.
Audio Interface		
R_HOST	7	Right audio channel from phone audio codec.
L_HOST	8	Left audio channel from phone audio codec.
Power Interface		
V _{CC}	2	Input voltage supply pin to be connected to the phone battery output.
Connector Interface		
GND	9	Ground
DP_CON	11	Connected to the USB connector D+ pin; depending on the FSA806 signaling mode, this pin can share DP_HOST1, DP_HOST2 or R_HOST signals.
DM_CON	10	Connected to the USB connector D- pin; depending on the FSA806 signaling mode, this pin can share DM_HOST1, DM_HOST2 or L_HOST signals.
Switch Control		
SEL[1:0]	12, 1	Switch selection pins; refer to Table 1 for truth table.

Absolute Maximum Ratings

Stresses exceeding the absolute maximum ratings may damage the device. The device may not function or be operable above the recommended operating conditions and stressing the parts to these levels is not recommended. In addition, extended exposure to stresses above the recommended operating conditions may affect device reliability. The absolute maximum ratings are stress ratings only.

Symbol	Parameter		Min.	Max.	Unit	
V_{CC}	Supply Voltage from Battery / Baseband		-0.5	6.0	V	
V_{SW}	Switch I/O Voltage	USB	-0.5	$V_{BUS}+0.5$	V	
		Stereo/Mono Audio Path Active	$V_{CC}-8.5$	$V_{CC}+0.5$		
		All Other Channels	-0.5	$V_{CC}+0.5$		
I_{IK}	Input Clamp Diode Current		-50		mA	
I_{SW}	Switch I/O Current (Continuous)	USB		50	mA	
		Audio		60		
		All Other Channels		50		
I_{SWPEAK}	Peak Switch Current (Pulsed at 1ms Duration, <10% Duty Cycle)	USB		150	mA	
		Audio		150	mA	
		All Other Channels		150	mA	
T_{STG}	Storage Temperature Range		-65	+150	°C	
T_J	Maximum Junction Temperature			+150	°C	
T_L	Lead Temperature (Soldering, 10 Seconds)			+260	°C	
ESD	IEC 61000-4-2 System	USB Connector Pins (D+, D-, V_{BUS})	Air Gap		15	kV
			Contact		8	
	Human Body Model, JEDEC JESD22-A114		All Pins		3	
	Charged Device Model, JEDEC JESD22-C101		All Pins		2	

Recommended Operating Conditions

The Recommended Operating Conditions table defines the conditions for actual device operation. Recommended operating conditions are specified to ensure optimal performance to the datasheet specifications. Fairchild does not recommend exceeding them or designing to Absolute Maximum Ratings.

Symbol	Parameter		Min.	Max.	Unit
V_{CC}	Battery Supply Voltage		2.7	4.4	V
V_{SW}	Switch I/O Voltage	USB/UART Path Active	0	4.4	V
		Audio Path Active	$V_{CC}-7$	2.0	V
T_A	Operating Temperature		-40	+85	°C

Switch Path DC Electrical Characteristics

All typical values are at 25°C unless otherwise specified.

Symbol	Parameter	V _{CC} (V)	Conditions	T _A = -40 to +85°C			Unit
				Min.	Typ.	Max.	
Host Interface Pins (SEL[2:0])							
V _{IH}	Input High Voltage	3.2 to 4.4		1.3			V
V _{IL}	Input Low Voltage	3.2 to 4.4				0.7	V
I _{IN}	Control Input Leakage	0 to 4.4	V _{SW} =0 to V _{CC}	-1		1	μA
I _{OZ}	Off-State Leakage	4.4	0 ≤ DP_CON, DM_CON, DP_HOSTn, DM_HOSTn, R_HOST, L_HOST ≤ 3.6V	-2		2	μA
Switch Off Characteristics							
I _{OFF}	Power-Off Leakage Current	0	All Ports Except MIC & Audio path V _{SW} =0V to 4.4V, Figure 8			10	μA
USB Switch On Paths							
R _{ONUSB}	HS USB Range Switch On Resistance	3.2 to 4.4	V _{DP_CON/DM_CON} =0V, 0.4V, I _{ON} =8mA, Figure 7		6	9	Ω
R _{ONUART}	UART Range Switch On Resistance	3.2 to 4.4	V _{DP_CON/DM_CON} =0V, 3.2V, I _{ON} =8mA, Figure 7		8		Ω
Audio R/L Switch On Paths							
R _{ONAUD}	Audio Switch On Resistance	3.2 to 4.4	V _{L/R} =-0.8V, 0.8V, I _{ON} =30mA, Figure 7			3	Ω
R _{FLAT}	Audio R _{ON} Flatness ⁽¹⁾	3.8			0.16		Ω
R _{TERM}	Internal Termination Resistors				1		kΩ
Total Switch Current Consumption							
I _{CCSL}	Battery Supply Sleep Mode Average Current	3.2 to 4.4	Static Current During Sleep Mode (SEL[2:0]=0)			1	μA
I _{CCWK}	Battery Supply Active Mode Average Current	3.2 to 4.4	USB/UART Mode		20	35	μA
			Audio Mode			1	μA
I _{CCSELT}	Increase in I _{CCSL} /I _{CCWK} Current per Control Voltage and V _{CC}	3.2 to 4.4	V _{SEL} =2.8V and V _{CC} =4.4V			8	μA
			V _{SEL} =1.8V and V _{CC} =4.4V			10	μA

Note:

- Flatness is defined as the difference between the maximum and minimum values of on resistance over the specified range of conditions.

Switch Path AC Electrical Characteristics⁽⁴⁾

All typical value are for $V_{CC} = 3.8V$ at 25°C unless otherwise specified.

Symbol	Parameter		V_{CC} (V)	Conditions	TA = -40 to +85°C			Unit	Figure
					Min.	Typ.	Max.		
Xtalk	Active Channel Crosstalk DP_CON to DM_CON	Audio Mode	3.8	f=20kHz, $R_T=32\Omega$, $C_L=0pF$		-95		dB	Figure 10
		USB Mode	3.8	f=1MHz, $R_T=50\Omega$, $C_L=0pF$		-75			
				f=240MHz, $R_T=50\Omega$, $C_L=0pF$		-36			
O_{IRR}	Off Isolation Rejection Ratio	Audio Rejection L_HOST to DM_CON, R_HOST to DP_CON	3.8	f=20kHz, $R_T=32\Omega$, $C_L=0pF$		-100		dB	Figure 9
		USB Rejection DM_HOST to DM_CON, DP_HOST to DP_CON	3.8	f=1 MHz, $R_T=50\Omega$, $C_L=0pF$		-85			
				f=240MHz, $R_T=50\Omega$, $C_L=0pF$		-35			
THD+N	Total Harmonic Distortion + Noise (Audio Path)	3.8	20Hz to 20kHz, $R_L=16\Omega$, Input Signal Range 1.6V _{PP}		0.10		%	Figure 14	
			20Hz to 20kHz, $R_L=32\Omega$, Input Signal Range 1.6V _{PP}		0.07		%	Figure 14	

Note:

4. Guaranteed by characterization; not production tested.

Capacitance

Symbol	Parameter	V_{CC} (V)	Conditions	TA = -40 to +85°C			Unit	Figure
				Min.	Typ.	Max.		
C_{IN}	Select Pins Capacitance ⁽⁵⁾	0	$V_{BIAS}=0.2V$		2.5		pF	Figure 12
$C_{OFF(D+, D-)}$	D+, D- On Capacitance (HS USB Mode) ⁽⁵⁾	3.8	$V_{BIAS}=0.2V$, f=1MHz		4.0		pF	Figure 12
$C_{ON(D+, D-)}$	D+, D- On Capacitance (HS USB Mode) ⁽⁵⁾	3.8	$V_{BIAS}=0.2V$, f=1MHz		6.8		pF	Figure 13

Note:

5. Guaranteed by characterization; not production tested.

High-Speed USB Eye Compliance Results

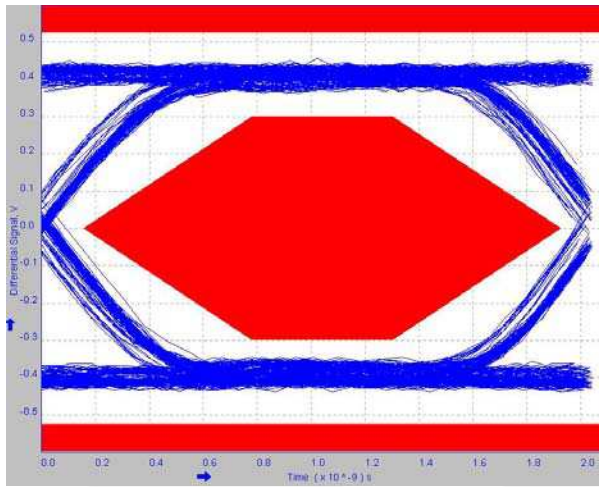

Figure 4. High-Speed Test Results (DP_CON/DM_CON – DP_HOST1/DM_HOST1)

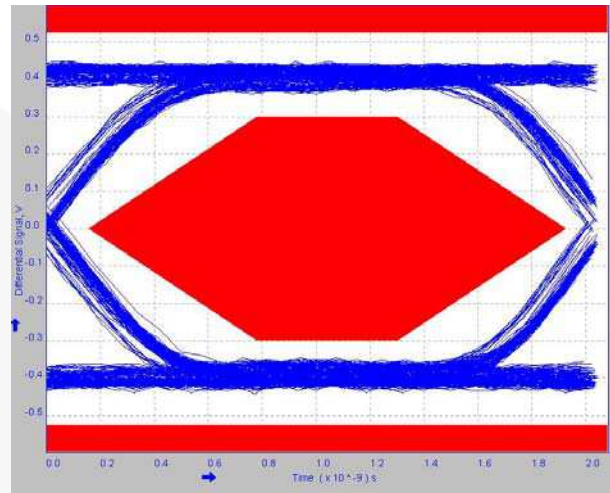

Figure 5. High-Speed Test Results (DP_CON/DM_CON – DP_HOST2/DM_HOST2)

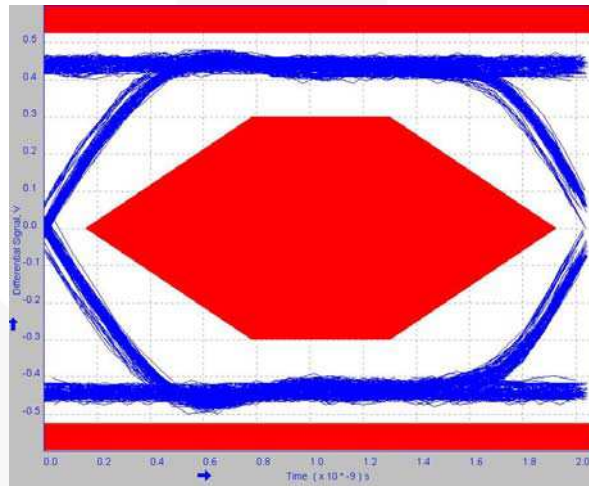

Figure 6. High-Speed Eye Compliance Input Signal

Test Diagrams

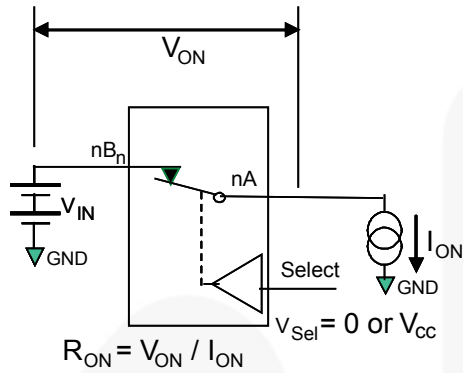
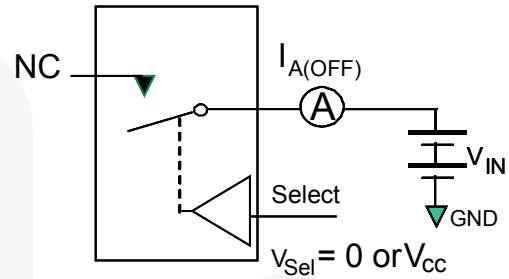

Figure 7. On Resistance



**Each switch port is tested separately.

Figure 8. Off Leakage

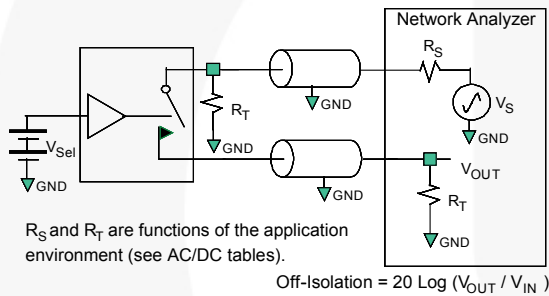

Figure 9. Channel Off Isolation

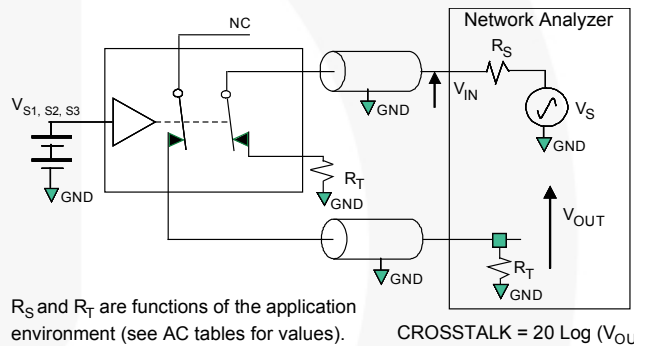

Figure 10. Active Channel Crosstalk

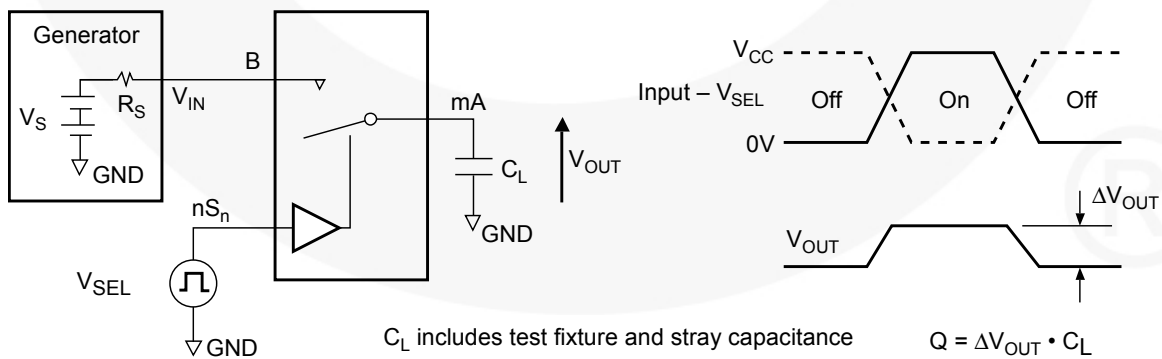

Figure 11. Charge Injection Test

Test Diagrams (Continued)

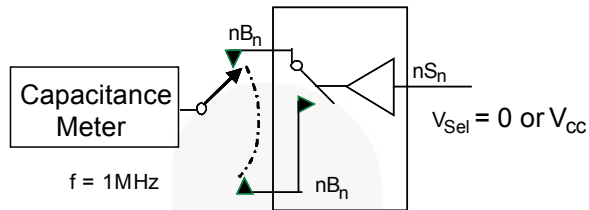

Figure 12. Channel Off Capacitance

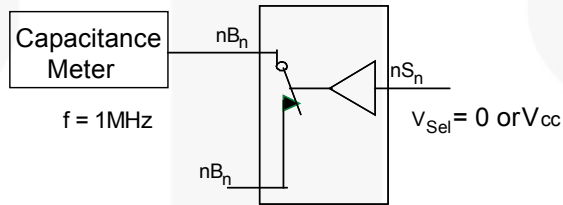

Figure 13. Channel On Capacitance

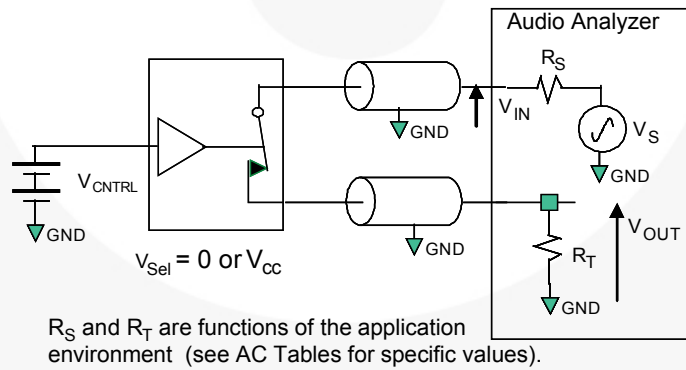

Figure 14. Total Harmonic Distortion + Noise

Physical Dimensions

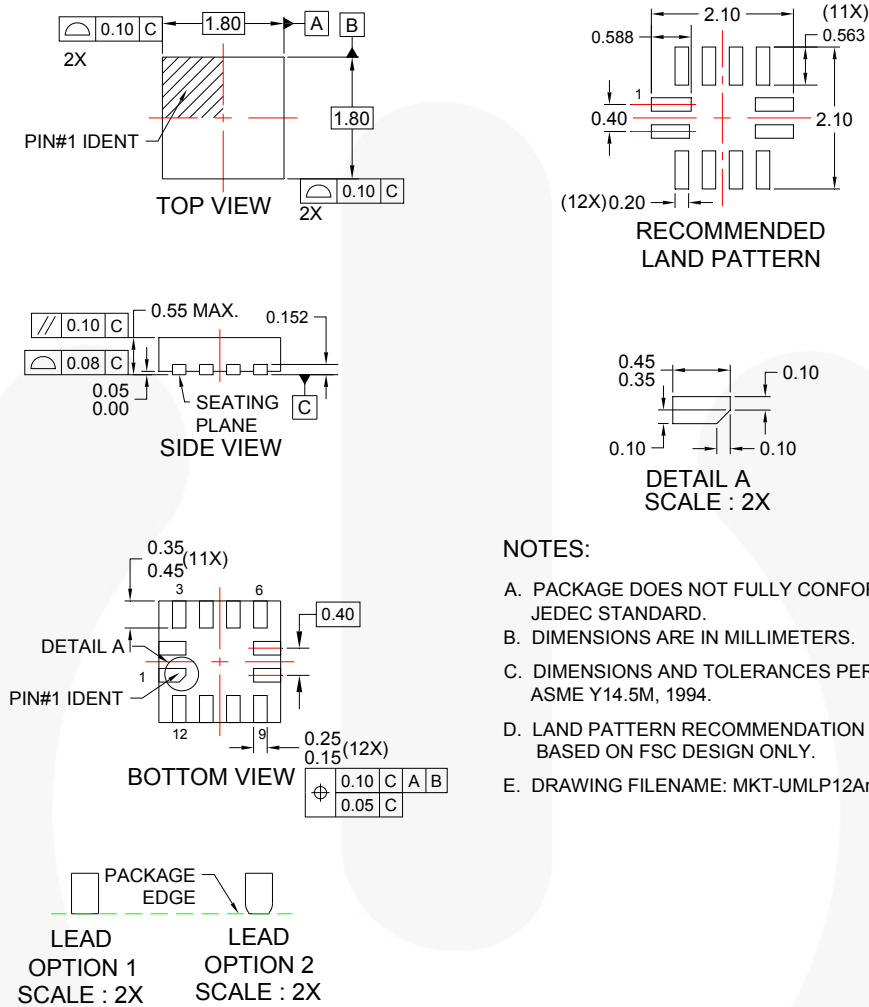

Figure 15. 12-Lead, Ultrathin Molded Leadless Package (UMLP)

Package drawings are provided as a service to customers considering Fairchild components. Drawings may change in any manner without notice. Please note the revision and/or date on the drawing and contact a Fairchild Semiconductor representative to verify or obtain the most recent revision. Package specifications do not expand the terms of Fairchild's worldwide terms and conditions, specifically the warranty therein, which covers Fairchild products.

Always visit Fairchild Semiconductor's online packaging area for the most recent package drawings:
<http://www.fairchildsemi.com/packaging/>



TRADEMARKS

The following includes registered and unregistered trademarks and service marks, owned by Fairchild Semiconductor and/or its global subsidiaries, and is not intended to be an exhaustive list of all such trademarks.

2Cool™
AccuPower™
AX-CAP™*
BITSiC™
Build it Now™
CorePLUS™
CorePOWER™
CROSSVOLT™
CTL™
Current Transfer Logic™
DEUXPEED®
Dual Cool™
EcoSPARK®
EfficientMax™
ESBC™
F®
Fairchild®
Fairchild Semiconductor®
FACT Quiet Series™
FACT®
FAST®
FastvCore™
FETBench™
FlashWriter®*
FPS™

F-PFS™
FRFET®
Global Power Resource™
GreenBridge™
Green FPS™
Green FPS™ e-Series™
Gmax™
GTO™
IntelliMAX™
ISOPLANAR™
Making Small Speakers Sound Louder and Better™
MegaBuck™
MICROCOUPLER™
MicroFET™
MicroPak™
MicroPak2™
MillerDrive™
MotionMax™
mWSaver™
OptoHIT™
OPTOLOGIC®
OPTOPLANAR®

PowerTrench®
PowerXS™
Programmable Active Droop™
QFET®
QS™
Quiet Series™
RapidConfigure™
™
Saving our world, 1mW/W/kW at a time™
SignalWise™
SmartMax™
SMART START™
Solutions for Your Success™
SPM®
STEALTH™
SuperFET®
SuperSOT™-3
SuperSOT™-6
SuperSOT™-8
SupreMOS®
SyncFET™
Sync-Lock™
 SYSTEM GENERAL®*

The Power Franchise®
the **power** franchise™
TinyBoost™
TinyBuck™
TinyCalc™
TinyLogic®
TINYOPTO™
TinyPower™
TinyPWM™
TinyWire™
TranSiC™
TriFault Detect™
TRUECURRENT®*
µSerDes™

UHC®
Ultra FRFET™
UniFET™
VCX™
VisualMax™
VoltagePlus™
XS™

* Trademarks of System General Corporation, used under license by Fairchild Semiconductor.

DISCLAIMER

FAIRCHILD SEMICONDUCTOR RESERVES THE RIGHT TO MAKE CHANGES WITHOUT FURTHER NOTICE TO ANY PRODUCTS HEREIN TO IMPROVE RELIABILITY, FUNCTION, OR DESIGN. FAIRCHILD DOES NOT ASSUME ANY LIABILITY ARISING OUT OF THE APPLICATION OR USE OF ANY PRODUCT OR CIRCUIT DESCRIBED HEREIN; NEITHER DOES IT CONVEY ANY LICENSE UNDER ITS PATENT RIGHTS, NOR THE RIGHTS OF OTHERS. THESE SPECIFICATIONS DO NOT EXPAND THE TERMS OF FAIRCHILD'S WORLDWIDE TERMS AND CONDITIONS, SPECIFICALLY THE WARRANTY THEREIN, WHICH COVERS THESE PRODUCTS.

LIFE SUPPORT POLICY

FAIRCHILD'S PRODUCTS ARE NOT AUTHORIZED FOR USE AS CRITICAL COMPONENTS IN LIFE SUPPORT DEVICES OR SYSTEMS WITHOUT THE EXPRESS WRITTEN APPROVAL OF FAIRCHILD SEMICONDUCTOR CORPORATION.

As used herein:

1. Life support devices or systems are devices or systems which, (a) are intended for surgical implant into the body or (b) support or sustain life, and (c) whose failure to perform when properly used in accordance with instructions for use provided in the labeling, can be reasonably expected to result in a significant injury of the user.
2. A critical component in any component of a life support, device, or system whose failure to perform can be reasonably expected to cause the failure of the life support device or system, or to affect its safety or effectiveness.

ANTI-COUNTERFEITING POLICY

Fairchild Semiconductor Corporation's Anti-Counterfeiting Policy. Fairchild's Anti-Counterfeiting Policy is also stated on our external website, www.fairchildsemi.com, under Sales Support.

Counterfeiting of semiconductor parts is a growing problem in the industry. All manufacturers of semiconductor products are experiencing counterfeiting of their parts. Customers who inadvertently purchase counterfeit parts experience many problems such as loss of brand reputation, substandard performance, failed applications, and increased cost of production and manufacturing delays. Fairchild is taking strong measures to protect ourselves and our customers from the proliferation of counterfeit parts. Fairchild strongly encourages customers to purchase Fairchild parts either directly from Fairchild or from Authorized Fairchild Distributors who are listed by country on our web page cited above. Products customers buy either from Fairchild directly or from Authorized Fairchild Distributors are genuine parts, have full traceability, meet Fairchild's quality standards for handling and storage and provide access to Fairchild's full range of up-to-date technical and product information. Fairchild and our Authorized Distributors will stand behind all warranties and will appropriately address any warranty issues that may arise. Fairchild will not provide any warranty coverage or other assistance for parts bought from Unauthorized Sources. Fairchild is committed to combat this global problem and encourage our customers to do their part in stopping this practice by buying direct or from authorized distributors.

PRODUCT STATUS DEFINITIONS

Definition of Terms

Datasheet Identification	Product Status	Definition
Advance Information	Formative / In Design	Datasheet contains the design specifications for product development. Specifications may change in any manner without notice.
Preliminary	First Production	Datasheet contains preliminary data; supplementary data will be published at a later date. Fairchild Semiconductor reserves the right to make changes at any time without notice to improve design.
No Identification Needed	Full Production	Datasheet contains final specifications. Fairchild Semiconductor reserves the right to make changes at any time without notice to improve the design.
Obsolete	Not In Production	Datasheet contains specifications on a product that is discontinued by Fairchild Semiconductor. The datasheet is for reference information only.

Rev. I62

ON Semiconductor and  are trademarks of Semiconductor Components Industries, LLC dba ON Semiconductor or its subsidiaries in the United States and/or other countries. ON Semiconductor owns the rights to a number of patents, trademarks, copyrights, trade secrets, and other intellectual property. A listing of ON Semiconductor's product/patent coverage may be accessed at www.onsemi.com/site/pdf/Patent-Marking.pdf. ON Semiconductor reserves the right to make changes without further notice to any products herein. ON Semiconductor makes no warranty, representation or guarantee regarding the suitability of its products for any particular purpose, nor does ON Semiconductor assume any liability arising out of the application or use of any product or circuit, and specifically disclaims any and all liability, including without limitation special, consequential or incidental damages. Buyer is responsible for its products and applications using ON Semiconductor products, including compliance with all laws, regulations and safety requirements or standards, regardless of any support or applications information provided by ON Semiconductor. "Typical" parameters which may be provided in ON Semiconductor data sheets and/or specifications can and do vary in different applications and actual performance may vary over time. All operating parameters, including "Typicals" must be validated for each customer application by customer's technical experts. ON Semiconductor does not convey any license under its patent rights nor the rights of others. ON Semiconductor products are not designed, intended, or authorized for use as a critical component in life support systems or any FDA Class 3 medical devices or medical devices with a same or similar classification in a foreign jurisdiction or any devices intended for implantation in the human body. Should Buyer purchase or use ON Semiconductor products for any such unintended or unauthorized application, Buyer shall indemnify and hold ON Semiconductor and its officers, employees, subsidiaries, affiliates, and distributors harmless against all claims, costs, damages, and expenses, and reasonable attorney fees arising out of, directly or indirectly, any claim of personal injury or death associated with such unintended or unauthorized use, even if such claim alleges that ON Semiconductor was negligent regarding the design or manufacture of the part. ON Semiconductor is an Equal Opportunity/Affirmative Action Employer. This literature is subject to all applicable copyright laws and is not for resale in any manner.

PUBLICATION ORDERING INFORMATION

LITERATURE FULFILLMENT:

Literature Distribution Center for ON Semiconductor
19521 E. 32nd Pkwy, Aurora, Colorado 80011 USA
Phone: 303-675-2175 or 800-344-3860 Toll Free USA/Canada
Fax: 303-675-2176 or 800-344-3867 Toll Free USA/Canada
Email: orderlit@onsemi.com

N. American Technical Support: 800-282-9855 Toll Free
USA/Canada
Europe, Middle East and Africa Technical Support:
Phone: 421 33 790 2910
Japan Customer Focus Center
Phone: 81-3-5817-1050

ON Semiconductor Website: www.onsemi.com
Order Literature: <http://www.onsemi.com/orderlit>
For additional information, please contact your local
Sales Representative