

Rev	AWO #	Description	Date	Appr
-		RELEASED	12/07/09	

APPROVED: \_\_\_\_\_  
 DATE: \_\_\_\_\_ TITLE: \_\_\_\_\_

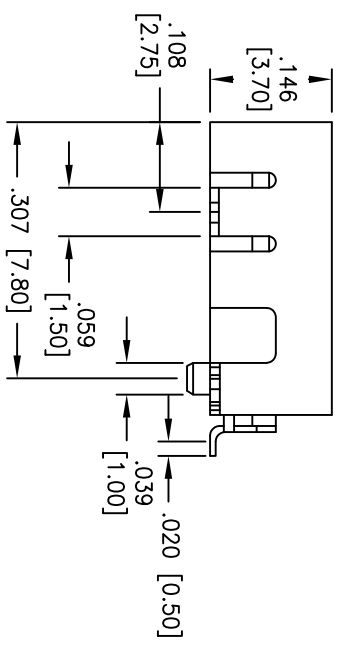
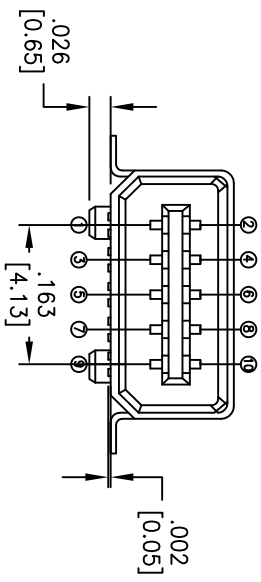
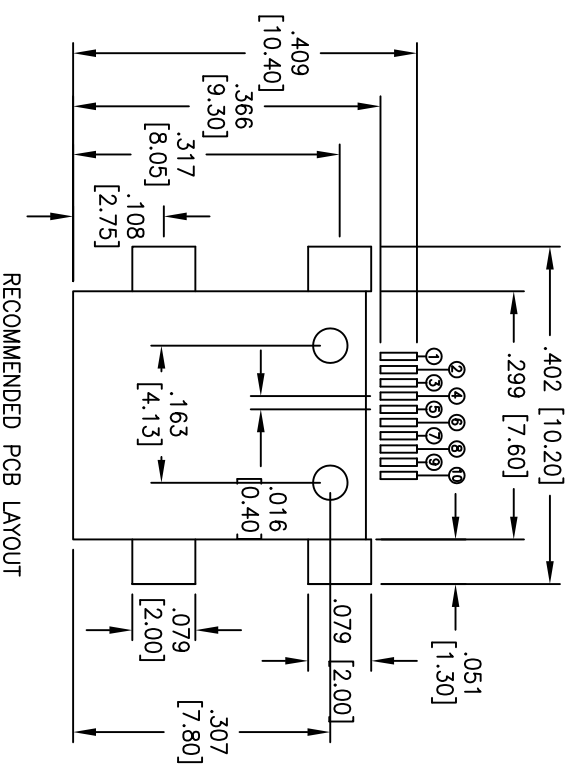
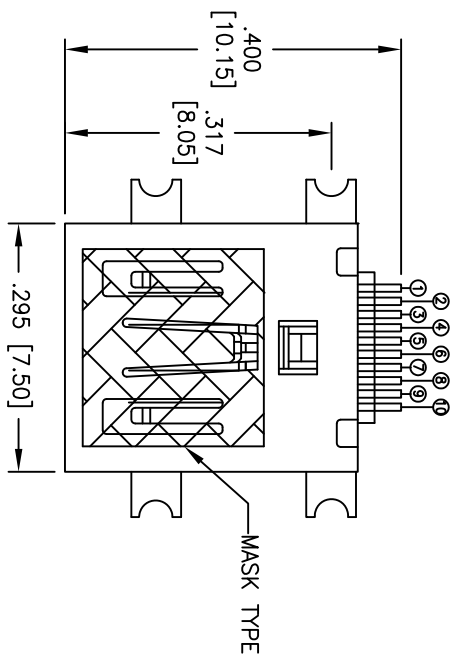

**SPECIFICATIONS:**

- Material: Insulator: LCP, rated UL 94V-0
- Insulator color: Black
- Contacts: Phosphor Bronze
- Shell: Brass, Nickel plated
- Plating: Gold flash over Nickel underplate overall

- Electrical: Contact resistance: 80 mohms max.
- Insulation resistance: 100 Mohms min.
- Dielectric withstanding voltage: 500 VAC for 1 minute
- Temperature Rating: Operating temperature: -55°C to +105°C



Lead free, RoHS compliant.  
 Recommended soldering temp: 260°C for 5 sec.

**ADAM TECH**

909 Railway Avenue, Union, NJ 07083  
 Phone: 908-687-5000 Fax: 908-687-5710

TITLE: MINI USB, 10P, FEMALE, SINGLE PORT  
 RIGHT ANGLE, TRUE SMT TYPE

UNLESS OTHERWISE SPECIFIED ALL DIMENSIONS ARE MM TOLERANCES: EXCEPT AS NOTED INCHES	
ØX ± .10	HOLES ± .10
.XX ± .020	ØXX ± .015
.XXX ± .015	ØXXX ± .010
APPROVALS	DATE
DRAWN DY	12/07/09
CHECKED	
APPROVED	

SIZE	PART NO.	REV.
X	MUSB-10P-S-RA-TSMT-1	-
REF: S000106T	SCALE: NTS	SHEET 1 OF 1