

Features

- Frequency Range: 32 to 38 GHz
- Small Signal Gain: 18 dB
- Saturated Power: 37 dBm
- Power Added Efficiency: 23%
- 100% On-Wafer RF and DC Testing
- 100% Visual Inspection to MIL-STD-883 Method 2010
- Bias $V_D = 6\text{ V}$, $I_D = 2.5\text{ A}$, $V_G = -0.9\text{ V}$
- Dimensions: 3.09 x 5.67 x 0.05 mm

Description

The MAAP-015016-DIE is a wideband power amplifier operating from 32 to 38 GHz, with a saturated output power of 37 dBm, 23% PAE and small signal gain of 18 dB.

The design is fully matched to 50 Ohms and includes on-chip ESD protection and integrated DC blocking caps on both I/O ports. The device is manufactured in 0.15 μm GaAs pHEMT device technology with BCB wafer coating to enhance ruggedness and repeatability of performance.

The part is well suited for Radar and Communications applications.

Ordering Information¹

Part Number	Package
MAAP-015016-DIE	Die in Gel Pack ¹
MAAP-015016-DIEEV1	Evaluation Module

1. Die quantity varies.

Functional Diagram

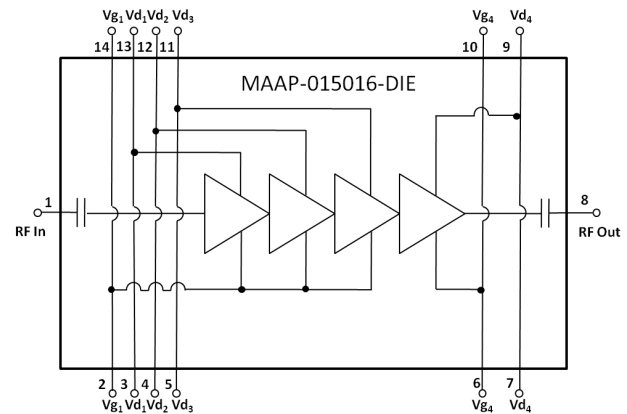

Pin Configuration²

Pad	Function	Description
1	RF _{IN}	Input, matched to 50 Ω
2,14	V _{G1,2,3}	Gate Voltage Stage 1 - 3
3,13	V _{D1}	Drain Voltage Stage 1
4,12	V _{D2}	Drain Voltage Stage 2
5,11	V _{D3}	Drain Voltage Stage 3
6,10	V _{G4}	Gate Voltage Stage 4
7,9	V _{D4}	Drain Voltage Stage 4
8	RF _{OUT}	Output, matched to 50 Ω

2. Backside metal is RF, DC and thermal ground.

* Restrictions on Hazardous Substances, European Union Directive 2011/65/EU

Electrical Specifications- Pulsed Operation:

Freq. = 32 - 38 GHz, $T_A = +25^\circ\text{C}$, $Z_0 = 50 \Omega$, Duty Cycle = 5%, Pulse = 5 μs , $P_{IN} = 20 \text{ dBm}$

Parameter	Test Conditions	Units	Min.	Typ.	Max.
Gain	—	dB	—	18	—
Input Return Loss	—	dB	—	10	—
Gain Flatness	—	dB	—	1.5	—
Output Return Loss	—	dB	—	14	—
Output Power at Saturation	33.0 - 36.0 GHz 36.0 - 36.5 GHz	dBm	35 34	37	—
PAE at Saturation	—	%	—	23	—
Drain Voltage	—	V	—	6	—
Gate Voltage	—	V	-1.1	-0.9	-0.8
Drain Current	—	A	-	2.5	-
Drain Current	Under RF Drive (33.0 - 36.5 GHz)	A	2	3.7	4.5

Electrical Specifications - CW Operation:

Freq. = 32 - 38 GHz, $T_A = +25^\circ\text{C}$, $Z_0 = 50 \Omega$, $P_{IN} = 20 \text{ dBm}$

Parameter	Test Conditions	Units	Min.	Typ.	Max.
Gain	—	dB	—	18	—
Gain Flatness	—	dB	—	1.5	—
Input Return Loss	—	dB	—	10	—
Output Return Loss	—	dB	—	14	—
Output Power at Saturation	—	dBm	—	36.5	—
PAE at Saturation	—	%	—	21	—
Drain Voltage	—	V	—	6	—
Gate Voltage	—	V	-1.1	-0.9	-0.8

Absolute Maximum Ratings^{2,3}

Parameter	Rating
Input Power, CW, 50 Ω	+23 dBm
Drain Voltage	+6.5 V
Gate Voltage	-2 to 0 V
Drain Current	4.5 A
Gate Current	-20 mA to 5 mA
Power Dissipation	20 W
Storage Temperature	-65°C to +165°C
Operating Temperature	-40°C to +85°C
Channel Temperature ^{4,5}	+175°C

- Exceeding any one or combination of these limits may cause permanent damage to this device.
- MACOM does not recommend sustained operation near these survivability limits.
- Operating at nominal conditions with $T_C \leq +175^\circ\text{C}$ will ensure $\text{MTTF} > 1 \times 10^6$ hours.
- Channel Temperature (T_C) = $T_A + \Theta_{jc} * ((V * I) - P_{out})$
 Typical thermal resistance (Θ_{jc}) = 4.3°C/W.
 - For $T_A = 25^\circ\text{C}$,
 $T_C = 90^\circ\text{C}$ @ 6 V, 2.5 A (Quiescent bias only)
 - For $T_A = 85^\circ\text{C}$,
 $T_C = 150^\circ\text{C}$ @ 6 V, 2.5 A (Quiescent bias only)

Recommended Operating Conditions

Parameter	Rating
Drain Voltage	+6 V
Gate Voltage	-0.9 V
Drain Current	2.5 A
Drain Current (Under RF Drive)	3.7 A

Handling Procedures

Please observe the following precautions to avoid damage:

Static Sensitivity

Gallium Arsenide Integrated Circuits are sensitive to electrostatic discharge (ESD) and can be damaged by static electricity. Proper ESD control techniques should be used when handling these HBM class 1B devices.

Application Circuit^{4,5,6,7}

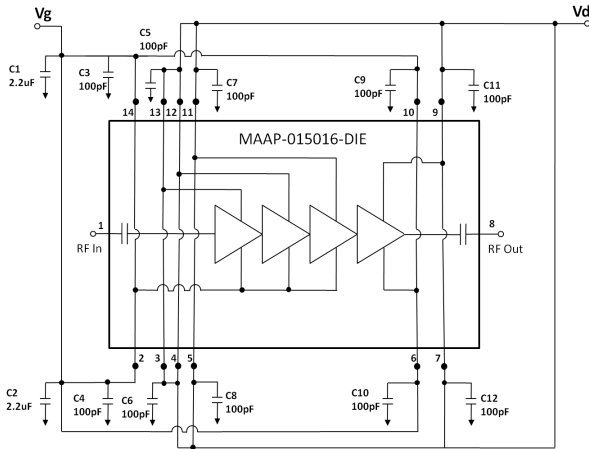

4. V_G must be biased from both sides (pins 2,6,10,14).
5. V_D must be biased from both sides (pins 3,4,5,7,9,11,12,13).
6. It is recommended that bias control circuits are used at V_G and V_D . Additional bypass capacitors may also be required depending on the application, 1 to 47 μF tantalum capacitors are commonly used here.
7. Each bias pad, V_G or V_D must have a decoupling capacitor as close to the device as possible, as is shown in the Assembly Drawing.

Assembly Drawing

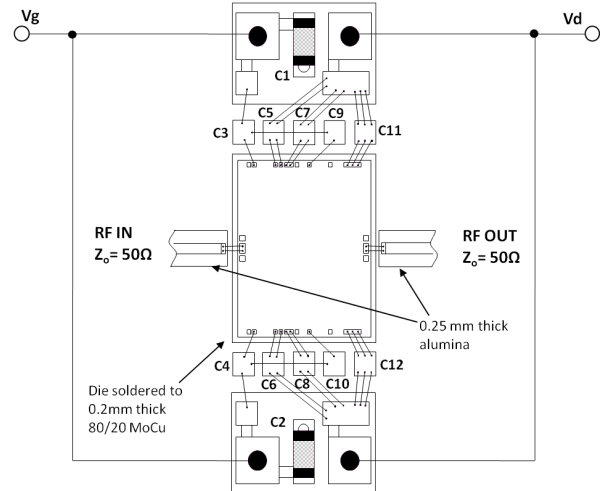

Parts List

Component	Value
C1, C2	2.2 μF
C3 - C12	100 pF

Operating the MAAP-015016

The MAAP-015016 is static sensitive. Please handle with care. To operate the device, follow these steps.

Using Up-Bias Procedure:

1. Set V_G to -1.5 V
2. Set V_D to +6 V
3. Adjust V_G positive until quiescent I_D is 2.5 A ($\sim V_G = -0.9$)
4. Apply RF signal to RF Input

Using Down-Bias Procedure:

1. Turn off RF supply
2. Reduce V_G to -1.5 V
3. Turn V_D to 0 V
4. Turn V_G to 0 V

Biasing -

It is recommended to use active biasing to keep the currents constant as the RF power and temperature vary; this gives the most reproducible results.

Pulse Operation -

The performance of the MAAP-015016-DIE is characterized under pulsed conditions with a duty cycle of 5% consisting of a pulse width of 5 μs applied to the drain. Under pulsed conditions the gate is constantly biased using a gate voltage directly applied to the PA. It is recommended that the die is mounted with an adequate thermal solution.

Typical Performance Curves - Pulsed Operation

S-Parameters vs. Frequency

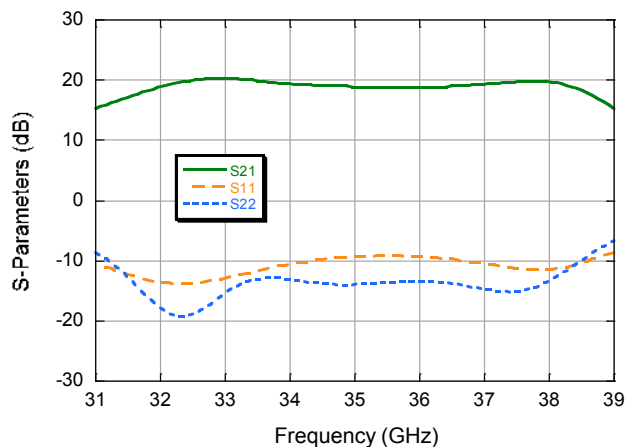

Output Power vs. Frequency

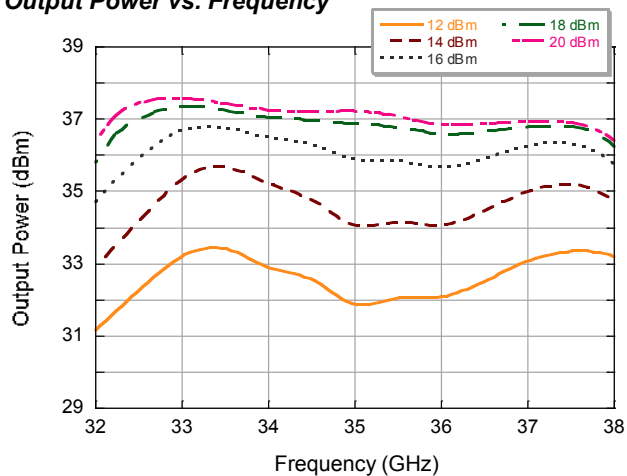

PAE vs. Frequency

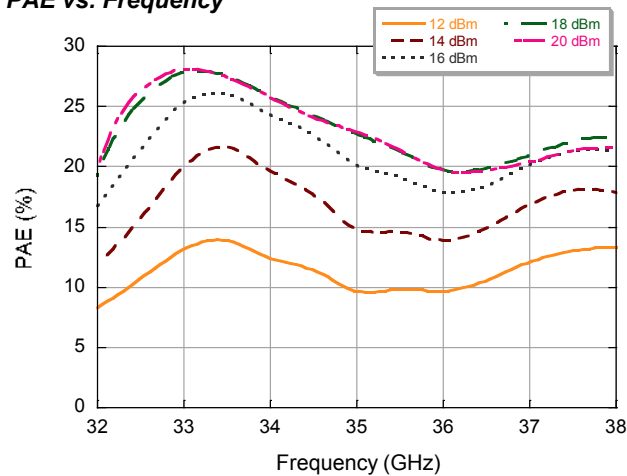

Typical Performance Curves - Pulsed Operation

Gain vs. Input Power

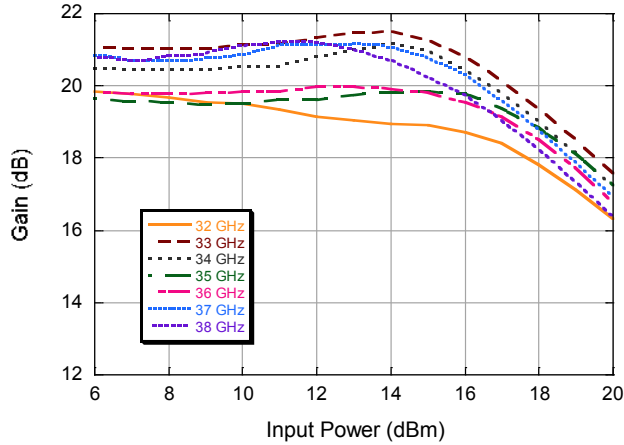

Output Power vs. Input Power

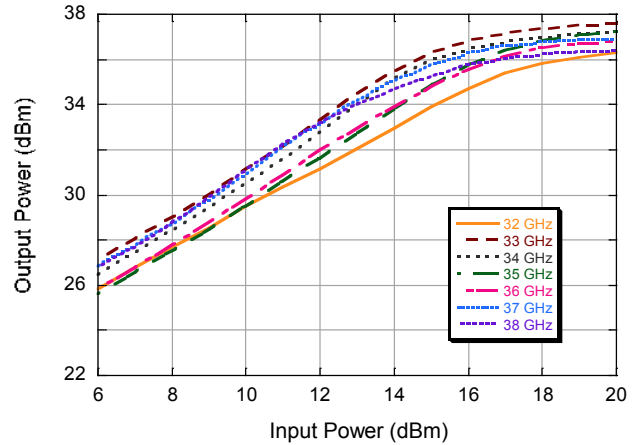

Drain Current vs. Input Power

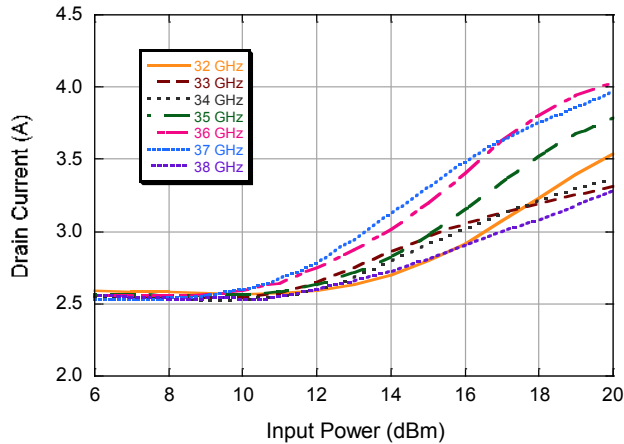

PAE vs. Input Power

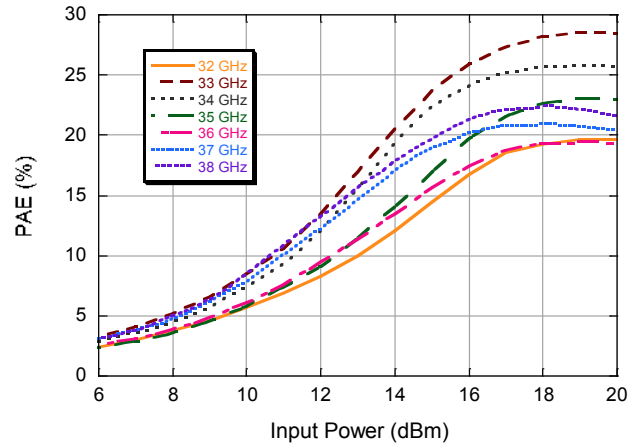

Typical Performance Curves- CW Operation

S-Parameters vs. Frequency

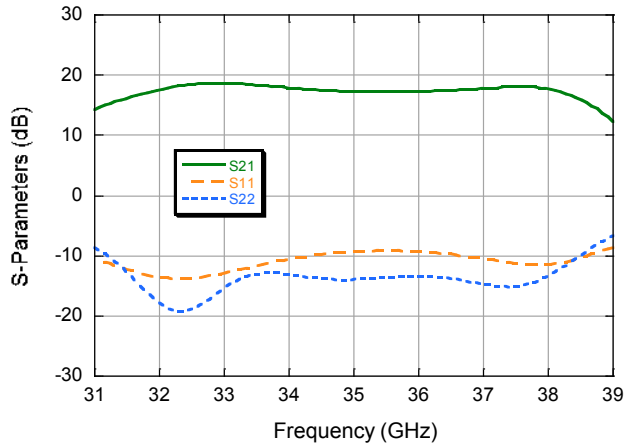

Output Power vs. Frequency

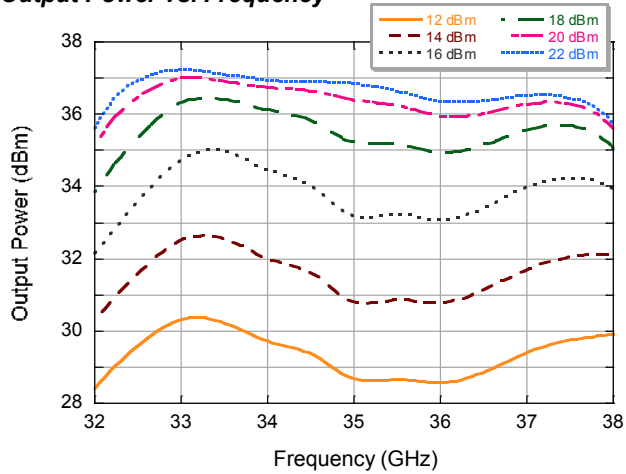

PAE vs. Frequency

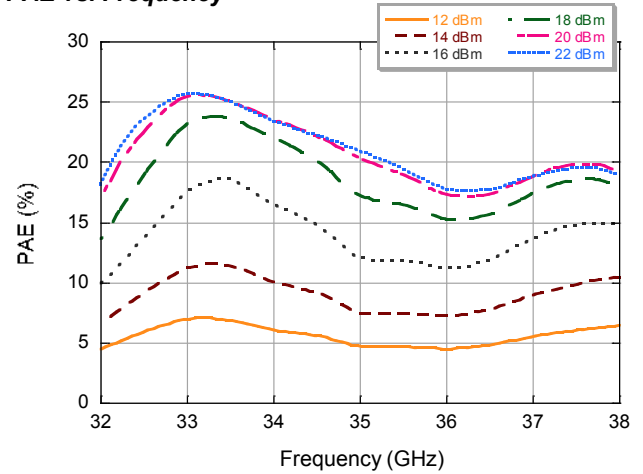

Typical Performance Curves- CW Operation

Gain vs. Input Power

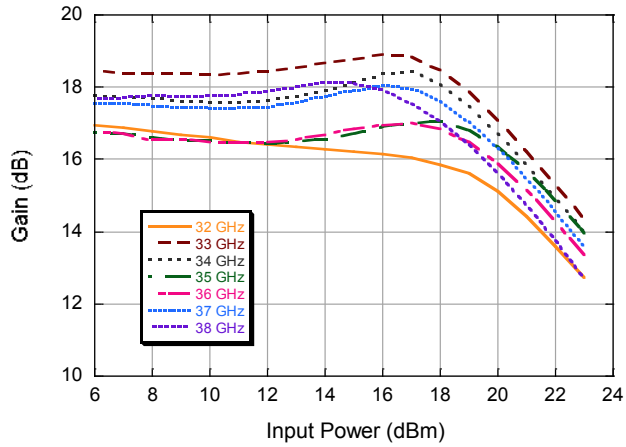

Output Power vs. Input Power

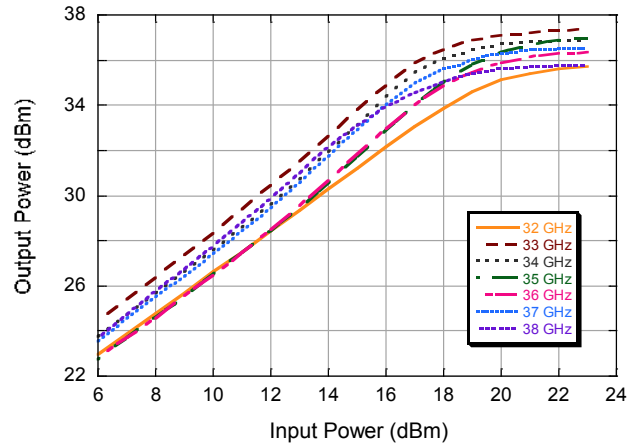

Drain Current vs. Input Power

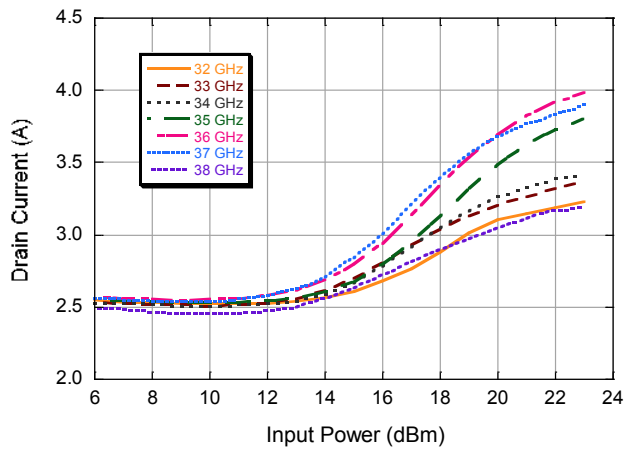

PAE vs. Input Power

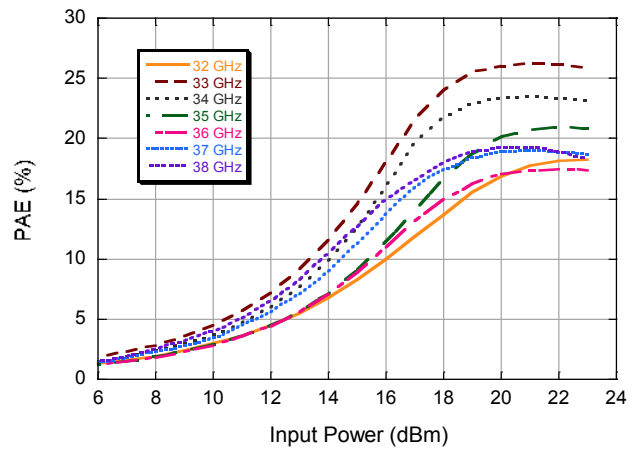

Die Outline

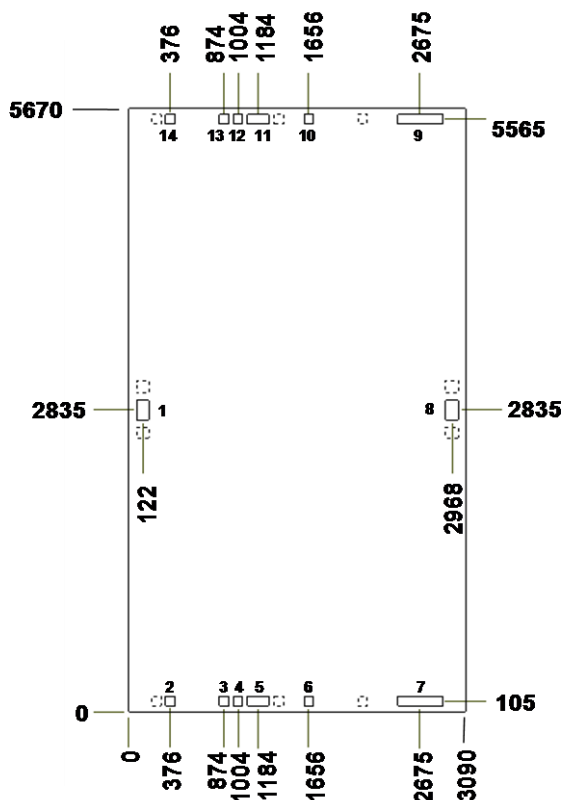

Thickness: 50 µm

Chip edge to bond pad dimensions are shown to center of pad

Ground is backside of die

Pad	Function	Pad Size	Description
1	RF _{IN}	117 x 197	Input, matched to 50 Ω
2,14	V _G 1,2,3	87 x 87	Gate Voltage Stage 1 - 3
3,13	V _D 1	87 x 87	Drain Voltage Stage 1
4,12	V _D 2	87 x 87	Drain Voltage Stage 2
5,11	V _D 3	207 x 87	Drain Voltage Stage 3
6,10	V _G 4	87 x 87	Gate Voltage Stage 4
7,9	V _D 4	407 x 87	Drain Voltage Stage 4
8	RF _{OUT}	117 x 197	Output, matched to 50 Ω

Applications Section

Handling and Assembly

Die Attachment

This product is 0.050 mm (0.002") thick and has vias through to the backside to enable grounding to the circuit. Microstrip substrates should be brought as close to the die as possible. The mounting surface should be clean and flat. If using conductive epoxy, recommended epoxies are Abletherm 2600A, Tanaka TS3332LD, Die Mat DM6030HK or DM6030HK-Pt cured in a nitrogen atmosphere per manufacturer's cure schedule. Apply epoxy sparingly to avoid getting any on to the top surface of the die. An epoxy fillet should be visible around the total die periphery. For additional information please see the MACOM "Epoxy Specifications for Bare Die" application note.

If eutectic mounting is preferred, then a flux-less gold-tin (AuSn) preform, approximately 0.0012 thick, placed between the die and the attachment surface should be used. A die bonder that utilizes a heated collet and provides scrubbing action to ensure total wetting to prevent void formation in a nitrogen atmosphere is recommended. The gold-tin eutectic (80% Au 20% Sn) has a melting point of approximately 280°C (Note: Gold Germanium should be avoided). The work station temperature should be 310°C +/- 10°C. Exposure to these extreme temperatures should be kept to minimum. The collet should be heated, and the die pre-heated to avoid excessive thermal shock. Avoidance of air bridges and force impact are critical during placement.

Wire Bonding

Windows in the surface passivation above the bond pads are provided to allow wire bonding to the die's gold bond pads. The recommended wire bonding procedure uses 0.076 mm x 0.013 mm (0.003" x 0.0005") 99.99% pure gold ribbon with 0.5-2% elongation to minimize RF port bond inductance. Gold 0.025 mm (0.001") diameter wedge or ball bonds are acceptable for DC Bias connections. Aluminium wire should be avoided. Thermo-compression bonding is recommended though thermo-sonic bonding may be used providing the ultrasonic content of the bond is minimized. Bond force, time and ultrasonic's are all critical parameters. Bonds should be made from the bond pads on the die to the package or substrate. All bonds should be as short as possible.

M/A-COM Technology Solutions Inc. All rights reserved.

Information in this document is provided in connection with M/A-COM Technology Solutions Inc ("MACOM") products. These materials are provided by MACOM as a service to its customers and may be used for informational purposes only. Except as provided in MACOM's Terms and Conditions of Sale for such products or in any separate agreement related to this document, MACOM assumes no liability whatsoever. MACOM assumes no responsibility for errors or omissions in these materials. MACOM may make changes to specifications and product descriptions at any time, without notice. MACOM makes no commitment to update the information and shall have no responsibility whatsoever for conflicts or incompatibilities arising from future changes to its specifications and product descriptions. No license, express or implied, by estoppel or otherwise, to any intellectual property rights is granted by this document.

THESE MATERIALS ARE PROVIDED "AS IS" WITHOUT WARRANTY OF ANY KIND, EITHER EXPRESS OR IMPLIED, RELATING TO SALE AND/OR USE OF MACOM PRODUCTS INCLUDING LIABILITY OR WARRANTIES RELATING TO FITNESS FOR A PARTICULAR PURPOSE, CONSEQUENTIAL OR INCIDENTAL DAMAGES, MERCHANTABILITY, OR INFRINGEMENT OF ANY PATENT, COPYRIGHT OR OTHER INTELLECTUAL PROPERTY RIGHT. MACOM FURTHER DOES NOT WARRANT THE ACCURACY OR COMPLETENESS OF THE INFORMATION, TEXT, GRAPHICS OR OTHER ITEMS CONTAINED WITHIN THESE MATERIALS. MACOM SHALL NOT BE LIABLE FOR ANY SPECIAL, INDIRECT, INCIDENTAL, OR CONSEQUENTIAL DAMAGES, INCLUDING WITHOUT LIMITATION, LOST REVENUES OR LOST PROFITS, WHICH MAY RESULT FROM THE USE OF THESE MATERIALS.

MACOM products are not intended for use in medical, lifesaving or life sustaining applications. MACOM customers using or selling MACOM products for use in such applications do so at their own risk and agree to fully indemnify MACOM for any damages resulting from such improper use or sale.