

Description

The power distribution system has been designed to accommodate plug-in type thermal circuit breakers type 1170-21, 1180 and 1610. It is a printed circuit board module for rail mounting. Typical applications are mainly in control cabinets for utility vehicles and special vehicles and for mobile construction machinery.

The current supplied by a power supply is distributed onto 5 ways/slots. There are two LEDs per circuit breaker. The red LED is lighted when the circuit breaker has tripped. The green LED is lighted when the circuit breaker is in ON condition. Group signalling is generated via the distributor. This signal can be enquired via a potential-free relay. The jumpers allow bridging the signalling for individual circuit breakers if those are not fitted.

Benefits

- Ease of cable management, reduced weight
- The circuit breakers can be plugged in in OFF condition with the system live
- One red and/or green LED per circuit breaker (ON/OFF)
- Potential-free group signalling
- Signalling can be bridged with a jumper in the event of empty slots
- Other population versions available upon request

Ordering information

Type

SBG power distribution

1170 thermal circuit breaker

Version, max. number of circuit breakers on the power distribution system

05 number of slots

0060 Ausführung

Signalisation

A Version A with signalling, red LED, 24 V DC

B Version B with signalling, green and red LED, 24 V DC

C Version C without signalling, without LED 12 V DC / 24 V DC

D Version D with signalling, green and red LED, 12 V DC

SBG-1170-05-V0060-A example

Preferred types

SBG-1170-05-V0060-B	With signalling (relay) with green and red LED, 24 V DC
SBG-1170-05-V0060-D	With signalling (relay) with green and red LED, 12 V DC

Overview of connections (terminals)

Model	terminals	supply terminals	load terminals	signalisation
SBG-1170-05-V0060-A/B/C/D	Federkraft	up to 16 mm ² (10 mm ² with wire end ferrule with plastic collar)	up to 6 mm ² (4 mm ² with wire end ferrule with plastic collar)	up to 2.5 mm ² (1.5 mm ² with wire end ferrule with plastic collar)

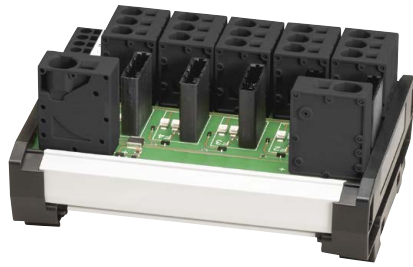

Technical Data

Dimensions including circuit breakers	121 x 92.3 x 66.2 bis 94 mm (l x w x h)
Rated voltage:	12 V DC / 24 V DC
Supply:	75 A spring-loaded terminal, a second terminal allows looping through
Load terminals:	5 ways per max. 25 A 3 spring-loaded terminals per way
Group signalling:	changeover contact 0.5 A (12 V DC / DC 24 V) spring-loaded terminals
Temperature range:	-20 ... +70 °C pcb protected against condensation by surface coating

Derating table

temperature	ambient	60 °C	70 °C
supply	75 A	60 A	50 A
load output	25 A	18.5 A	16 A

Note

- The circuit breakers must only be plugged in or removed in the OFF condition.
- The max. supply current of the individual printed circuit boards has to be observed when looping through several distribution modules.
- The LEDs and the signalling require a mass potential (0 V), max. 2 A connected via spring-loaded terminals up to 2.5 mm² (1.5 mm² with wire end ferrule with plastic collar), a second terminal allows looping through.
- Circuit breakers are not included in delivery.

Schematic diagram

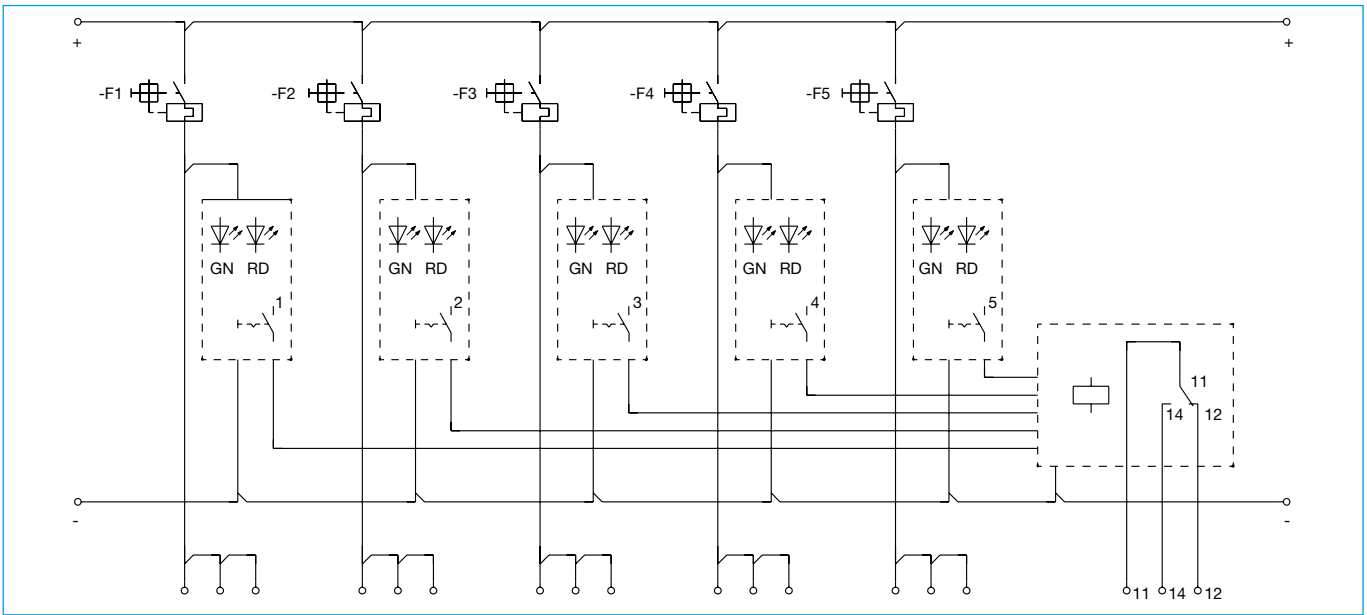

Dimensions

