

LOC	DIST	REVISIONS			
CM	00	REV	DATE	BY	APPV
		R	30AUG2012	KH	SM

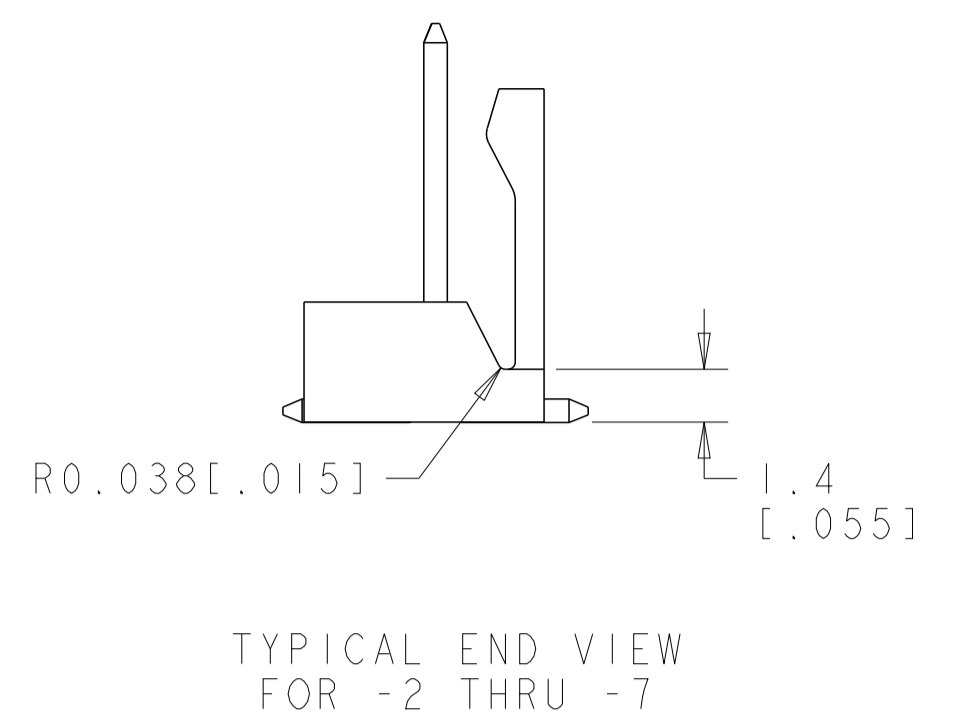

- 1. POST WITHSTAND 13 NEWTONS (3 LBS) MIN AXIAL FORCE IN DIRECTION SHOWN WITHOUT DISLODGING.
- 2. MEASURED AT [-A-].
- 3. PARTS COMPLY WITH SOLDERABILITY SPEC 109-11-2.
- 4. MATERIAL: HOUSING: NYLON, 4/6, HIGH TEMP, BLACK.
POST -2 THRU -12 COPPER ALLOY TIN LEAD (93/7) PLATING.
POST -32 THRU -42 COPPER ALLOY TIN PLATING.
- 5. COORDINATE DIMENSION APPLIES FROM CENTER OF ACTUAL FEATURE.
- 6. POSTS TO BE MEASURED WHEN STRIP HELD FLAT.
- 7. DIMENSIONS IN BRACKETS ARE IN INCHES.
- 8. TE LOGO, UL, AND CSA TRADEMARKS TO APPEAR ON THIS SURFACE.

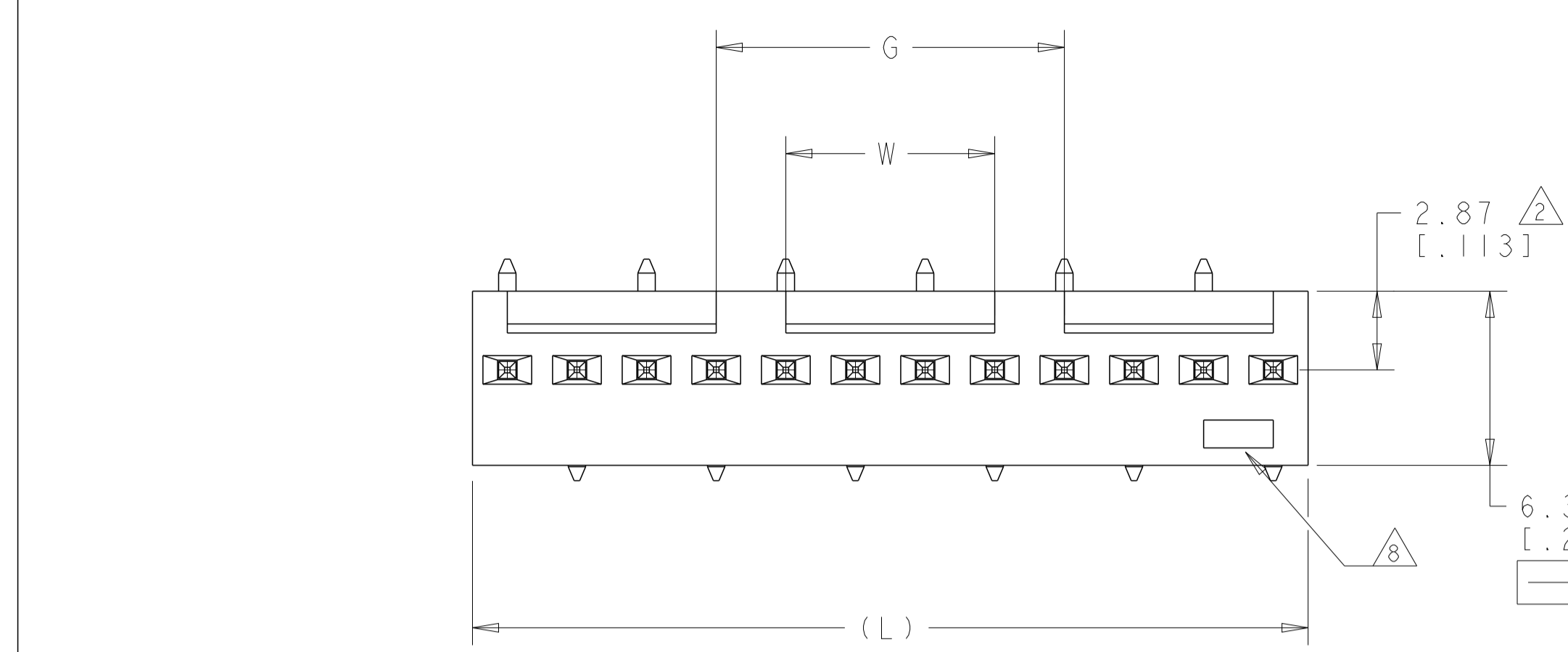
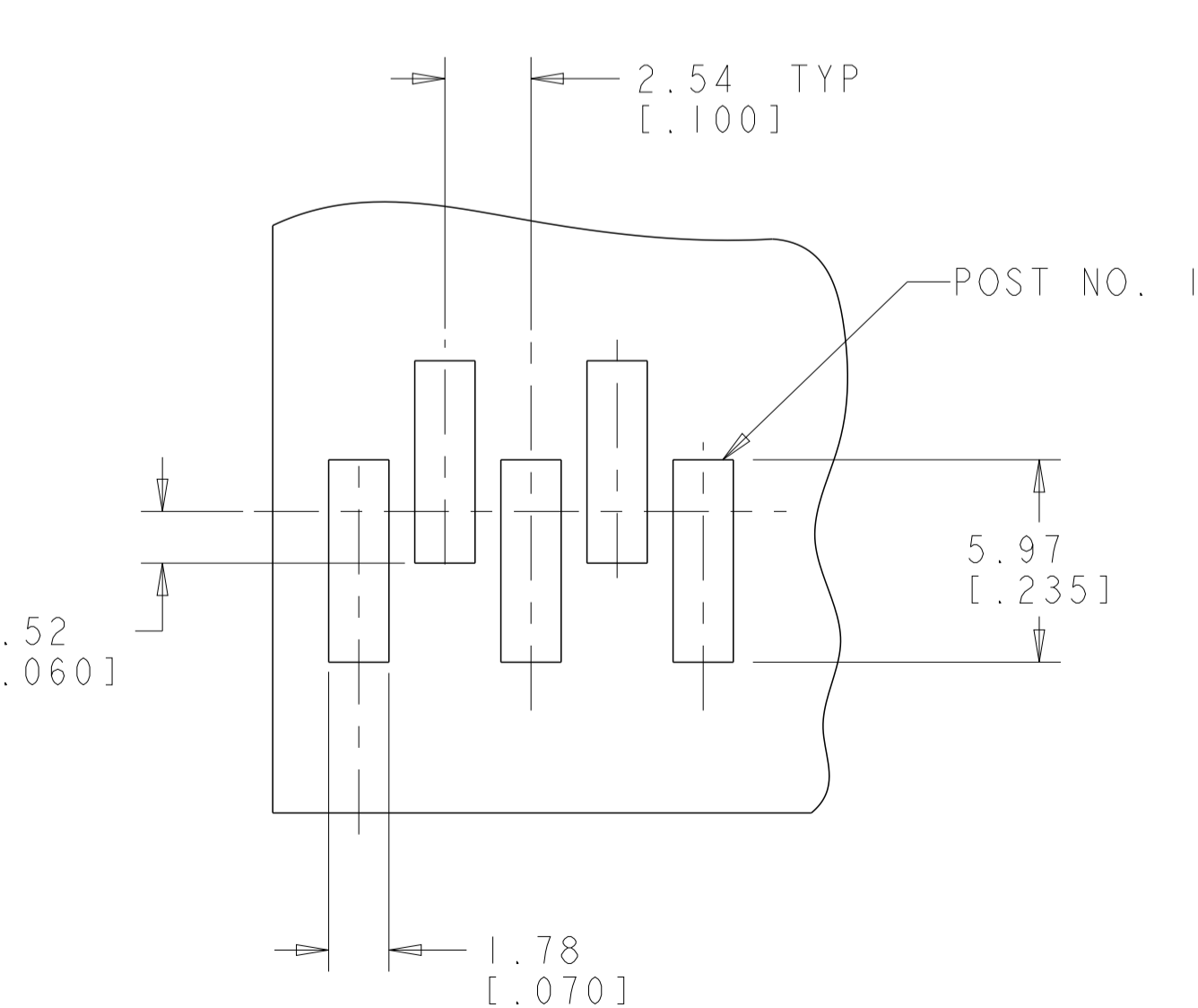
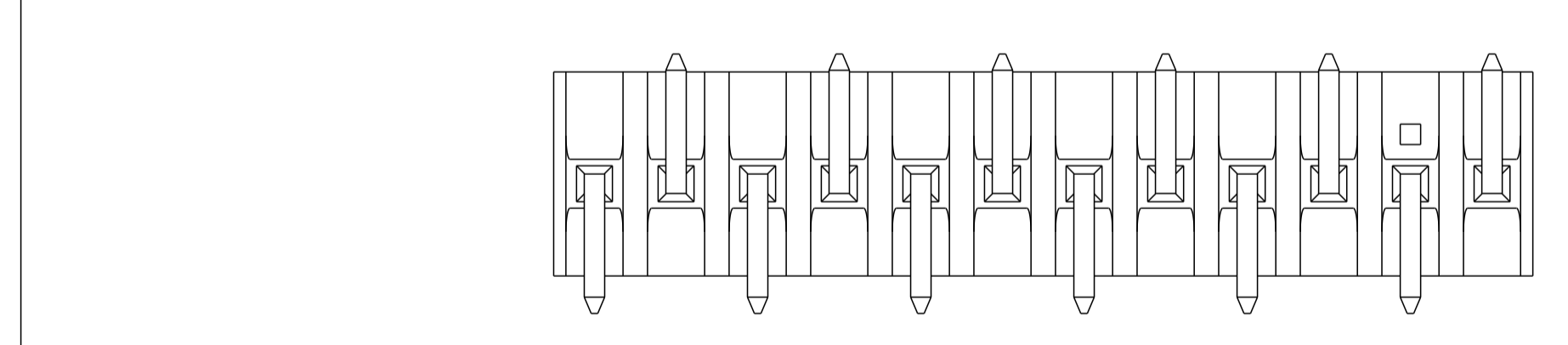
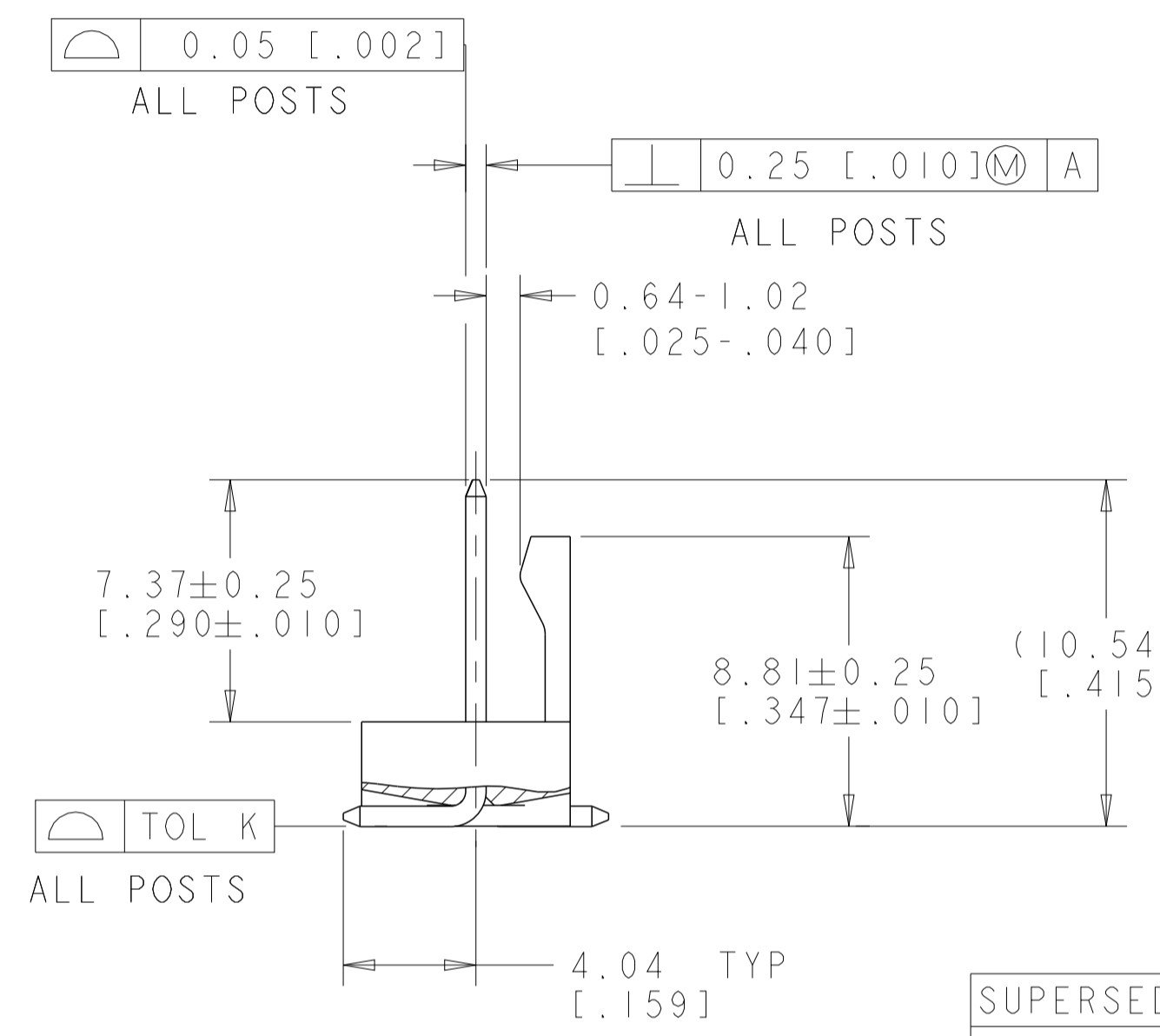
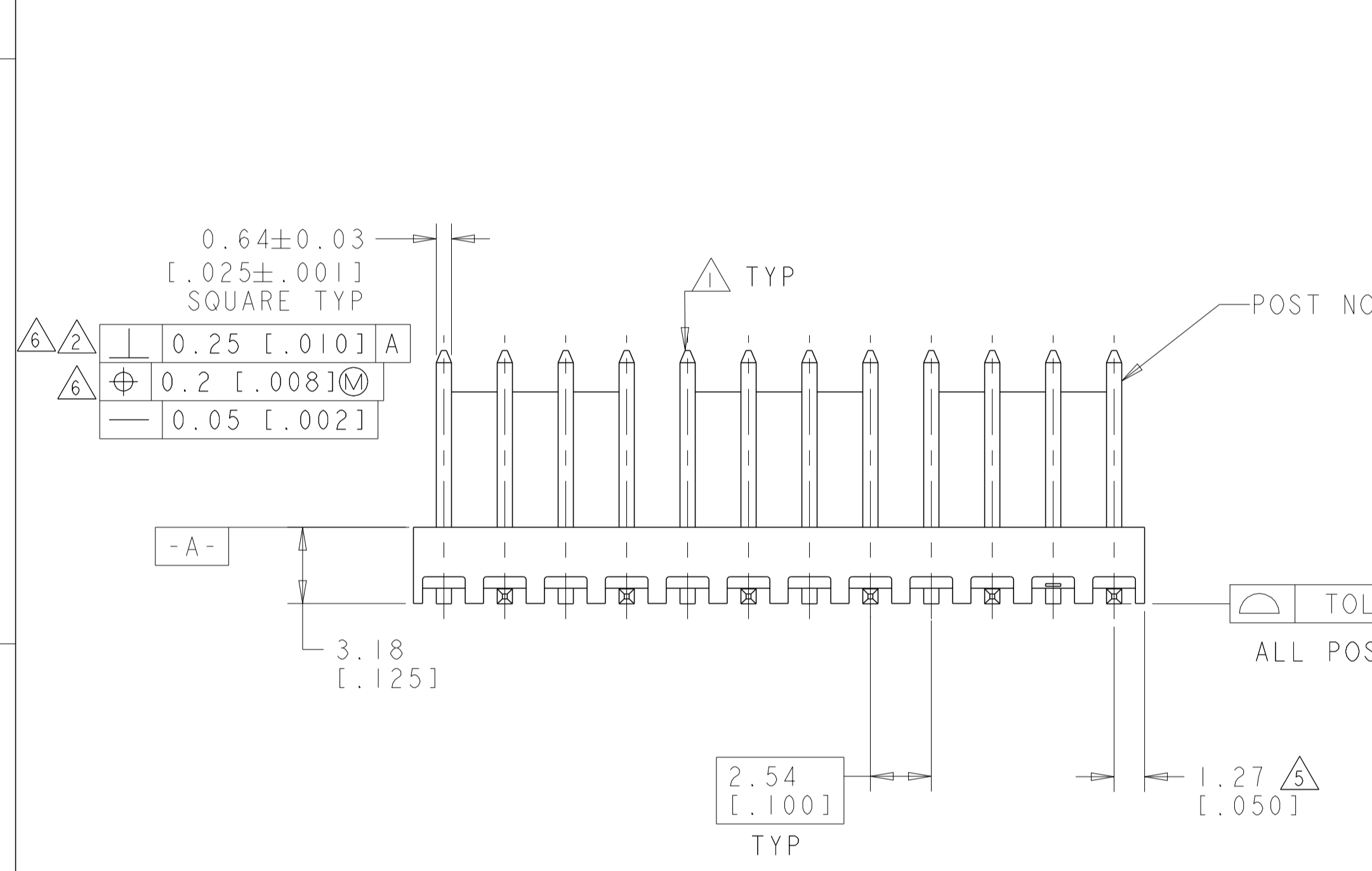

	0.20 [0.008]	12.70 [0.500]	27.94 [1.100]	45.72 [1.800]	18	4-647166-8
SUPERSEDED BY 647166-MXCU	0.20 [0.008]	12.70 [0.500]	17.78 [0.700]	35.56 [1.400]	14	4-647166-4
SUPERSEDED BY 647166-MXCU	0.15 [0.006]	7.62 [0.300]	12.70 [0.500]	30.48 [1.200]	12	4-647166-2
	0.15 [0.006]	-	10.16 [0.400]	27.94 [1.100]	11	4-647166-1
	0.15 [0.006]	-	7.62 [0.300]	25.40 [1.000]	10	4-647166-0
	0.15 [0.006]	-	5.08 [0.200]	22.86 [0.900]	9	3-647166-9
	0.15 [0.006]	-	2.54 [0.100]	20.32 [0.800]	8	3-647166-8
	0.15 [0.006]	-	-	17.78 [0.700]	7	3-647166-7
	0.15 [0.006]	-	-	15.24 [0.600]	6	3-647166-6
	0.15 [0.006]	-	-	12.70 [0.500]	5	3-647166-5
	0.15 [0.006]	-	-	10.16 [0.400]	4	3-647166-4
	0.15 [0.006]	-	-	7.62 [0.300]	3	3-647166-3
	0.15 [0.006]	-	-	5.08 [0.200]	2	3-647166-2
SUPERSEDED BY 647166-MXCU	0.20 [0.008]	12.70 [0.500]	27.94 [1.100]	45.72 [1.800]	18	1-647166-8
SUPERSEDED BY 647166-MXCU	0.20 [0.008]	12.70 [0.500]	17.78 [0.700]	35.56 [1.400]	14	1-647166-4
	0.15 [0.006]	7.62 [0.300]	12.70 [0.500]	30.48 [1.200]	12	1-647166-2
OBSOLETE	0.15 [0.006]	-	10.16 [0.400]	27.94 [1.100]	11	1-647166-1
	0.15 [0.006]	-	7.62 [0.300]	25.40 [1.000]	10	1-647166-0
OBSOLETE	0.15 [0.006]	-	5.08 [0.200]	22.86 [0.900]	9	647166-9
	0.15 [0.006]	-	2.54 [0.100]	20.32 [0.800]	8	647166-8
	0.15 [0.006]	-	-	17.78 [0.700]	7	647166-7
	0.15 [0.006]	-	-	15.24 [0.600]	6	647166-6
	0.15 [0.006]	-	-	12.70 [0.500]	5	647166-5
	0.15 [0.006]	-	-	10.16 [0.400]	4	647166-4
	0.15 [0.006]	-	-	7.62 [0.300]	3	647166-3
	0.15 [0.006]	-	-	5.08 [0.200]	2	647166-2
TOL K		W	G	L	NO OF POSN	PART NO

RECOMMENDED MOUNTING HOLE PATTERN FOR USE WITH 0.25 [0.010] THICK STENCIL

THIS DRAWING IS A CONTROLLED DOCUMENT. DWN: R. WHITAKER 2-NOV-2001
CHK: D. BOSSI 14-NOV-2001

STE TE Connectivity

DIMENSIONS: mm [INCHES] TOLERANCES UNLESS OTHERWISE SPECIFIED:

0 PLC	±
1 PLC	±0.131(.005)
2 PLC	±
3 PLC	±
4 PLC	±
ANGLES	±0°30'
FINISH	±

MATERIAL: APPLICATION SPEC:

SIZE: A1 CAGE CODE: 00779 DRAWING NO: 647166

CUSTOMER DRAWING SCALE: 5:1 SHEET 1 OF 1 REV R