



Numonyx™ Wireless Flash Memory (W18)

Datasheet

Product Features

- High Performance Read-While-Write/Erase
 - Burst frequency at 66 MHz (zero wait states)
 - 60 ns Initial access read speed
 - 11 ns Burst mode read speed
 - 20 ns Page mode read speed
 - 4-, 8-, 16-, and Continuous-Word Burst mode reads
 - Burst and Page mode reads in all Blocks, across all partition boundaries
 - Burst Suspend feature
 - Enhanced Factory Programming at 3.1 μ s/word
- Security
 - 128-Bit OTP Protection Register: 64 unique pre-programmed bits + 64 user-programmable bits
 - Absolute Write Protection with V_{pp} at ground
 - Individual and Instantaneous Block Locking/Unlocking with Lock-Down Capability
- Quality and Reliability
 - Temperature Range: -40 °C to +85 °C
 - 100K Erase Cycles per Block
 - 90 nm ETOX™ IX Process
 - 130 nm ETOX™ VIII Process
- Architecture
 - Multiple 4-Mbit partitions
 - Dual Operation: RWW or RWE
 - Parameter block size = 4-Kword
 - Main block size = 32-Kword
 - Top or bottom parameter devices
 - 16-bit wide data bus
- Software
 - 5 μ s (typ.) Program and Erase Suspend latency time
 - Flash Data Integrator (FDI) and Common Flash Interface (CFI) Compatible
 - Programmable WAIT signal polarity
- Packaging and Power
 - 90 nm: 32- and 64-Mbit in VF BGA
 - 130 nm: 32-, 64-, and 128-Mbit in VF BGA
 - 130 nm: 128-Mbit in QUAD+ package
 - 56 Active Ball Matrix, 0.75 mm Ball-Pitch
 - V_{CC} = 1.70 V to 1.95 V
 - V_{CCQ} (90 nm) = 1.7 V to 1.95 V
 - V_{CCQ} (130 nm) = 1.7 V to 2.24 V or 1.35 V to 1.80 V
 - V_{CCQ} (130 nm) = 1.35 V to 2.24 V
 - Standby current (130 nm): 8 μ A (typ.)
 - Read current: 8 mA (4-word burst, typ.)

INFORMATION IN THIS DOCUMENT IS PROVIDED IN CONNECTION WITH NUMONYX™ PRODUCTS. NO LICENSE, EXPRESS OR IMPLIED, BY ESTOPPEL OR OTHERWISE, TO ANY INTELLECTUAL PROPERTY RIGHTS IS GRANTED BY THIS DOCUMENT. EXCEPT AS PROVIDED IN NUMONYX'S TERMS AND CONDITIONS OF SALE FOR SUCH PRODUCTS, NUMONYX ASSUMES NO LIABILITY WHATSOEVER, AND NUMONYX DISCLAIMS ANY EXPRESS OR IMPLIED WARRANTY, RELATING TO SALE AND/OR USE OF NUMONYX PRODUCTS INCLUDING LIABILITY OR WARRANTIES RELATING TO FITNESS FOR A PARTICULAR PURPOSE, MERCHANTABILITY, OR INFRINGEMENT OF ANY PATENT, COPYRIGHT OR OTHER INTELLECTUAL PROPERTY RIGHT. Numonyx products are not intended for use in medical, life saving, life sustaining, critical control or safety systems, or in nuclear facility applications.

Numonyx B.V. may make changes to specifications and product descriptions at any time, without notice.

Numonyx B.V. may have patents or pending patent applications, trademarks, copyrights, or other intellectual property rights that relate to the presented subject matter. The furnishing of documents and other materials and information does not provide any license, express or implied, by estoppel or otherwise, to any such patents, trademarks, copyrights, or other intellectual property rights.

Designers must not rely on the absence or characteristics of any features or instructions marked "reserved" or "undefined." Numonyx reserves these for future definition and shall have no responsibility whatsoever for conflicts or incompatibilities arising from future changes to them.

Contact your local Numonyx sales office or your distributor to obtain the latest specifications and before placing your product order.

Copies of documents which have an order number and are referenced in this document, or other Numonyx literature may be obtained by visiting Numonyx's website at <http://www.numonyx.com>.

Numonyx, the Numonyx logo, and StrataFlash are trademarks or registered trademarks of Numonyx B.V. or its subsidiaries in other countries.

*Other names and brands may be claimed as the property of others.

Copyright © 2007, Numonyx B.V., All Rights Reserved.

Contents

1.0	Introduction	7
1.1	Nomenclature	7
1.2	Conventions	8
2.0	Functional Overview	9
2.1	Memory Map and Partitioning	10
3.0	Package Information	13
3.1	W18 — 90 nm Lithography	13
3.2	W18 — 130 nm	14
4.0	Ballout and Signal Descriptions	16
4.1	Signal Ballout	16
4.2	Signal Descriptions	18
5.0	Maximum Ratings and Operating Conditions	21
5.1	Absolute Maximum Ratings	21
5.2	Operating Conditions	21
6.0	Electrical Specifications	23
6.1	DC Current Characteristics	23
6.2	DC Voltage Characteristics	24
7.0	AC Characteristics	26
7.1	AC Write Characteristics	36
7.2	Erase and Program Times	42
7.3	Reset Specifications	43
7.4	AC I/O Test Conditions	44
7.5	Device Capacitance	45
8.0	Power and Reset Specifications	46
8.1	Active Power	46
8.2	Automatic Power Savings (APS)	46
8.3	Standby Power	46
8.4	Power-Up/Down Characteristics	46
8.4.1	System Reset and RST#	46
8.4.2	VCC, VPP, and RST# Transitions	47
8.5	Power Supply Decoupling	47
9.0	Bus Operations Overview	48
9.1	Bus Operations	48
9.1.1	Reads	48
9.1.2	Writes	49
9.1.3	Output Disable	49
9.1.4	Burst Suspend	49
9.1.5	Standby	50
9.1.6	Reset	50
9.2	Device Commands	50
9.3	Command Sequencing	53
10.0	Read Operations	55
10.1	Asynchronous Page Read Mode	55
10.2	Synchronous Burst Read Mode	55
10.3	Read Array	56
10.4	Read Identifier	56

10.5	CFI Query	57
10.6	Read Status Register.....	57
10.7	Clear Status Register	58
11.0	Program Operations	59
11.1	Word Program	59
11.2	Factory Programming	60
11.3	Enhanced Factory Program (EFP)	61
11.3.1	EFP Requirements and Considerations	61
11.3.2	Setup.....	62
11.3.3	Program	62
11.3.4	Verify.....	62
11.3.5	Exit.....	63
12.0	Program and Erase Operations	65
12.1	Program/Erase Suspend and Resume	65
12.2	Block Erase.....	67
12.3	Read-While-Write and Read-While-Erase.....	69
13.0	Security Modes	71
13.1	Block Lock Operations	71
13.1.1	Lock.....	72
13.1.2	Unlock.....	72
13.1.3	Lock-Down	72
13.1.4	Block Lock Status	73
13.1.5	Lock During Erase Suspend.....	73
13.1.6	Status Register Error Checking	73
13.1.7	WP# Lock-Down Control.....	74
13.2	Protection Register.....	74
13.2.1	Reading the Protection Register	75
13.2.2	Programing the Protection Register	75
13.2.3	Locking the Protection Register.....	75
13.3	VPP Protection.....	77
14.0	Set Read Configuration Register	78
14.1	Read Mode (RCR[15])	79
14.2	First Access Latency Count (RCR[13:11]).....	79
14.2.1	Latency Count Settings.....	80
14.3	WAIT Signal Polarity (RCR[10])	81
14.4	WAIT Signal Function	81
14.5	Data Hold (RCR[9]).....	82
14.6	WAIT Delay (RCR[8])	83
14.7	Burst Sequence (RCR[7]).....	83
14.8	Clock Edge (RCR[6])	84
14.9	Burst Wrap (RCR[3]).....	84
14.10	Burst Length (RCR[2:0]).....	85
A	Write State Machine States	86
B	Common Flash Interface (CFI)	89
C	Ordering Information	99

Revision History

Date	Revision	Description
09/13/00	-001	Initial Release
01/29/01	-002	<p>Deleted 16-Mbit density</p> <p>Revised <i>ADV#</i>, Section 2.2</p> <p>Revised <i>Protection Registers</i>, Section 4.16</p> <p>Revised <i>Program Protection Register</i>, Section 4.18</p> <p>Revised Example in <i>First Access Latency Count</i>, Section 5.0.2</p> <p>Revised Figure 5, <i>Data Output with LC Setting at Code 3</i></p> <p>Added <i>WAIT Signal Function</i>, Section 5.0.3</p> <p>Revised <i>WAIT Signal Polarity</i>, Section 5.0.4</p> <p>Revised <i>Data Output Configuration</i>, Section 5.0.5</p> <p>Added Figure 7, <i>Data Output Configuration with WAIT Signal Delay</i></p> <p>Revised <i>WAIT Delay Configuration</i>, Section 5.0.6</p> <p>Changed V_{CCQ} Spec from 1.7 V – 1.95 V to 1.7 V – 2.24 V in Section 8.2, <i>Extended Temperature Operation</i></p> <p>Changed I_{CCS} Spec from 15 μA to 18 μA in Section 8.4, <i>DC Characteristics</i></p> <p>Changed I_{CCR} Spec from 10 mA (CLK = 40 MHz, burst length = 4) and 13 mA (CLK = 52 MHz, burst length = 4) to 13 mA, and 16 mA respectively in Section 8.4, <i>DC Characteristics</i></p> <p>Changed I_{CCWS} Spec from 15 μA to 18 μA in Section 8.4, <i>DC Characteristics</i></p> <p>Changed I_{CCES} Spec from 15 μA to 18 μA in Section 8.4, <i>DC Characteristics</i></p> <p>Changed t_{CHQX} Spec from 5 ns to 3 ns in Section 8.6, <i>AC Read Characteristics</i></p> <p>Added Figure 25, <i>WAIT Signal in Synchronous Non-Read Array Operation Waveform</i></p> <p>Added Figure 26, <i>WAIT Signal in Asynchronous Page Mode Read Operation Waveform</i></p> <p>Added Figure 27, <i>WAIT Signal in Asynchronous Single Word Read Operation Waveform</i></p> <p>Revised Appendix E, <i>Ordering Information</i></p>
06/12/01	-003	<p>Revised entire Section 4.10, <i>Enhanced Factory Program Command (EFP)</i> and Figure 6, <i>Enhanced Factory Program Flowchart</i></p> <p>Revised Section 4.13, <i>Protection Register</i></p> <p>Revised Section 4.15, <i>Program Protection Register</i></p> <p>Revised Section 7.3, <i>Capacitance</i>, to include 128-Mbit specs</p> <p>Revised Section 7.4, <i>DC Characteristics</i>, to include 128-Mbit specs</p> <p>Revised Section 7.6, <i>AC Read Characteristics</i>, to include 128-Mbit device specifications</p> <p>Added t_{VHGL} Spec in Section 7.6, <i>AC Read Characteristics</i></p> <p>Revised Section 7.7, <i>AC Write Characteristics</i>, to include 128-Mbit device specifications</p> <p>Minor text edits</p>
04/05/02	-004	<p>New Sections Organization</p> <p>Added 16-Word Burst Feature</p> <p>Added Burst Suspend Section</p> <p>Revised Block Locking State Diagram</p> <p>Revised Active Power Section, Automatic Power Savings (APS) Section and Power-Up/Down Operation Section</p> <p>Revised Extended Temperature Operation</p> <p>Added 128 Mb DC Characteristics Table and AC Read Characteristics Table</p> <p>Revised Table 17. Test Configuration Component Values for Worst Case Speed Conditions</p> <p>Added 0.13 μm Product DC and AC Read Characteristics</p> <p>Revised AC Write Characteristics</p> <p>Added Read to Write and Write to Read Transition Waveforms</p> <p>Revised Reset Specifications</p> <p>Various text edits</p>

Date	Revision	Description
10/10/02	-005	Various text edits Updated Latency Count Section, including adding Latency Count Tables Added section 8.4 WAIT Function and WAIT Summary Table Updated Package Drawing and Dimensions
11/12/02	-006	Various text clarifications
01/14/03	-007	Removed Numonyx Burst Order Revised Table 10 "DC Current Characteristics" Various text edits
03/21/03	-008	Revised Table 22, Read Operations, t_{APA} Added note to table 15, Configuration Register Descriptions Added note to section 3.1.1, Read
12/17/03	-009	Updated Block-Lock Operations (Section 7.1 and Figure 11) Updated Table 21 (128 Mb I_{CCR}) Updated Table 4 (WAIT behavior) Added QUAD+ ballout, package mechanicals, and order information Various text edits including latest product-naming convention
02/12/04	-010	Added 90 nm product line; Removed μ BGA* package Added Page- and Burst-Mode descriptions; Minor text edits
05/06/04	-011	Fixed omitted text for Table 21, note 1 regarding max DC voltage on I/O pins Removed Extended I/O Supply Voltage for 90 nm products Minor text edits
06/03/04	-012	Updated the title and layout of the datasheet
06/29/04	-013	V_{CCQ} Max. changed for 90 nm products Updated "Absolute Maximum Ratings" table Typical I_{CCS} updated as 35 μ A Updated subtitle
01/21/05	-014	Typical I_{CCS} updated as 22 μ A Minor text edits
07-Dec-2005	-015	Typical 90nm APS updated to 22 μ A in Table 11, "DC Current Characteristics" on page 23. Updated 90nm V_{LKO} to 0.7 V in Table 12, "DC Voltage Characteristics" on page 24. Product ordering information updated.
December 2006	016	Added line item RD48F1000W0YTQ0 and RD48F1000W0YBQ0, in QUAD+ ballout, 10x8x1.2 package. Removed extended range voltage specifications that are no longer supported. Removed t_{AVQV}/t_{CHQV} 80ns/14ns; Applied new template/format.
August 2007	017	Updated ordering information
November 2007	18	Applied Numonyx branding.

1.0 Introduction

This datasheet contains information about the Numonyx™ Wireless Flash Memory (W18) device family. This section describes nomenclature used in the datasheet. [Section 2.0](#) provides an overview of the W18 flash memory device. [Section 6.0](#), [Section 7.0](#), and [Section 8.0](#) describe the electrical specifications for extended temperature product offerings. Ordering information can be found in [Section C](#).

The Numonyx™ Wireless Flash Memory (W18) device with flexible multi-partition dual-operation architecture, provides high-performance Asynchronous and Synchronous Burst reads. It is an ideal memory for low-voltage burst CPUs. Combining high read performance with flash memory intrinsic non-volatility, the W18 device eliminates the traditional system-performance paradigm of shadowing redundant code memory from slow nonvolatile storage to faster execution memory. It reduces total memory requirement that increases reliability and reduces overall system power consumption and cost. The W18 device’s flexible multi-partition architecture allows program or erase to occur in one partition while reading from another partition. This allows for higher data write throughput compared to single-partition architectures and designers can choose code and data partition sizes. The dual-operation architecture allows two processors to interleave code operations while program and erase operations take place in the background.

1.1 Nomenclature

Table 1: Acronyms

APS	Automatic Power Savings
BBA	Block Base Address
CFI	Common Flash Interface
CUI	Command User Interface
DU	Don't Use
EFP	Enhanced Factory Programming
FDI	Flash Data Integrator
NC	No Connect
OTP	One-Time Programmable
PBA	Partition Base Address
RCR	Read Configuration Register
RWE	Read-While-Erase
RWW	Read-While-Write
SCSP	Stacked Chip Scale Package
SRD	Status Register Data
VF BGA	Very-thin, Fine-pitch, Ball Grid Array
WSM	Write State Machine

1.2 Conventions

Table 2: Conventions

"1.8 V"	Refers to the full V _{CC} voltage range of 1.7 V – 1.95 V (except where noted) and "V _{PP} = 12 V" refers to 12 V ±5%.
Set	Refers to registers means the bit is a logical 1 and cleared means the bit is a logical 0.
Pin and signal	Often used interchangeably to refer to the external signal connections on the package (<i>ball</i> is the term used for VF BGA).
Word	2 bytes or 16 bits.
Signal	Names are in all CAPS (see Section 4.2, "Signal Descriptions" on page 18.)
Voltage	Applied to the signal is subscripted for example V _{pp} .
Throughout this document, references are made to top, bottom, parameter, and partition. To clarify these references, the following conventions have been adopted:	
Block	A group of bits (or words) that erase simultaneously with one block erase instruction.
Main block	Contains 32-Kwords.
Parameter block	Contains 4-Kwords.
Block Base Address (BBA)	The first address of a block.
Partition	A group of blocks that share erase and program circuitry and a common Status Register.
Partition Base Address (PBA)	The first address of a partition. For example, on a 32-Mbit top-parameter device partition number 5 has a PBA of 0x140000.
Top partition	Located at the highest physical device address. This partition may be a main partition or a parameter partition.
Bottom partition	Located at the lowest physical device address. This partition may be a main partition or a parameter partition.
Main partition	Contains only main blocks.
Parameter partition	Contains a mixture of main blocks and parameter blocks.
Top parameter device	Has the parameter partition at the top of the memory map with the parameter blocks at the top of that partition. This was formerly referred to as a Top-Boot device.
Bottom parameter device (BPD)	Has the parameter partition at the bottom of the memory map with the parameter blocks at the bottom of that partition. This was formerly referred to as a Bottom-Boot Block flash device.

2.0 Functional Overview

This section provides an overview of the W18 device features and architecture.

The W18 device provides Read-While-Write (RWW) and Read-White-Erase (RWE) capability with high-performance synchronous and asynchronous reads on package-compatible densities with a 16-bit data bus. Individually-erasable memory blocks are optimally sized for code and data storage. Eight 4-Kword parameter blocks are located in the parameter partition at either the top or bottom of the memory map. The rest of the memory array is grouped into 32-Kword main blocks.

The memory architecture for the W18 device consists of multiple 4-Mbit partitions, the exact number depending on device density. By dividing the memory array into partitions, program or erase operations can take place simultaneously during read operations. Burst reads can traverse partition boundaries, but user application code is responsible for ensuring that they don't extend into a partition that is actively programming or erasing. Although each partition has burst-read, write, and erase capabilities, simultaneous operation is limited to write or erase in one partition while other partitions are in a read mode.

Augmented erase-suspend functionality further enhances the RWW capabilities of this device. An erase can be suspended to perform a program or read operation within any block, except that which is erase-suspended. A program operation nested within a suspended erase can subsequently be suspended to read yet another memory location.

After device power-up or reset, the W18 device defaults to asynchronous page-mode read configuration. Writing to the device's Read Configuration Register (RCR) enables synchronous burst-mode read operation. In synchronous mode, the CLK input increments an internal burst address generator. CLK also synchronizes the flash memory with the host CPU and outputs data on every, or on every other, valid CLK cycle after an initial latency. A programmable WAIT output signals to the CPU when data from the flash memory device is ready.

In addition to its improved architecture and interface, the W18 device incorporates Enhanced Factory Programming (EFP), a feature that enables fast programming and low-power designs. The EFP feature provides the fastest currently-available program performance, which can increase a factory's manufacturing throughput.

The device supports read operations at 1.8 V and erase and program operations at 1.8 V or 12 V. With the 1.8 V option, VCC and VPP can be tied together for a simple, ultra-low-power design. In addition to voltage flexibility, the dedicated VPP input provides complete data protection when $V_{PP} \leq V_{PPLK}$.

This device (130 nm) allows I/O operation at voltages lower than the minimum V_{CCQ} of 1.7 V. This Extended V_{CCQ} range, 1.35 V – 1.8 V, permits even greater system design flexibility.

A 128-bit protection register enhances the user's ability to implement new security techniques and data protection schemes. Unique flash device identification and fraud-, cloning-, or content- protection schemes are possible through a combination of factory-programmed and user-OTP data cells. Zero-latency locking/unlocking on any memory block provides instant and complete protection for critical system code and data. An additional block lock-down capability provides hardware protection where software commands alone cannot change the block's protection status.

The Command User Interface (CUI) is the system processor's link to internal flash memory operation. A valid command sequence written to the CUI initiates device Write State Machine (WSM) operation that automatically executes the algorithms, timings,

and verifications necessary to manage flash memory program and erase. An internal Status Register provides ready/busy indication results of the operation (success, fail, and so on).

Three power-saving features— Automatic Power Savings (APS), standby, and RST# – can significantly reduce power consumption. The device automatically enters APS mode following read cycle completion. Standby mode begins when the system deselected the flash memory by de-asserting CE#. Driving RST# low produces power savings similar to standby mode. It also resets the part to read-array mode (important for system-level reset), clears internal Status Registers, and provides an additional level of flash write protection.

2.1 Memory Map and Partitioning

The W18 device is divided into 4-Mbit physical partitions, which allows simultaneous RWW or RWE operations and allows users to segment code and data areas on 4-Mbit boundaries. The device's memory array is asymmetrically blocked, which enables system code and data integration within a single flash device. Each block can be erased independently in block erase mode. Simultaneous program and erase operations are not allowed; only one partition at a time can be actively programming or erasing. See [Table 3, "Bottom Parameter Memory Map" on page 11](#) and [Table 4, "Top Parameter Memory Map" on page 12](#).

The 32-Mbit device has eight partitions, the 64-Mbit device has 16 partitions, and the 128-Mbit device has 32 partitions. Each device density contains one parameter partition and several main partitions. The 4-Mbit parameter partition contains eight 4-Kword parameter blocks and seven 32-Kword main blocks. Each 4-Mbit main partition contains eight 32-Kword blocks each.

The bulk of the array is divided into main blocks that can store code or data, and parameter blocks that allow storage of frequently updated small parameters that are normally stored in EEPROM. By using software techniques, the word-rewrite functionality of EEPROMs can be emulated.

Table 3: Bottom Parameter Memory Map

		Size (KW)	Blk #	32-Mbit	Blk #	64-Mbit	Blk #	128-Mbit
Main Partitions	Sixteen Partitions	32					262	7F8000-7FFFFFFF
		: ·					: ·	
		32					135	400000-407FFF
	Eight Partitions	32			134	3F8000-3FFFFFFF	134	3F8000-3FFFFFFF
		: ·			: ·	: ·	: ·	
		32			71	200000-207FFF	71	200000-207FFF
	Four Partitions	32	70	1F8000-1FFFFFFF	70	1F8000-1FFFFFFF	70	1F8000-1FFFFFFF
		: ·	: ·	: ·	: ·	: ·	: ·	: ·
		32	39	100000-107FFF	39	100000-107FFF	39	100000-107FFF
	One Partition	32	38	0F8000-0FFFFFFF	38	0F8000-0FFFFFFF	38	0F8000-0FFFFFFF
		: ·	: ·	: ·	: ·	: ·	: ·	: ·
		32	31	0C0000-0C7FFF	31	0C0000-0C7FFF	31	0C0000-0C7FFF
One Partition	32	30	0B8000-0BFFFF	30	0B8000-0BFFFF	30	0B8000-0BFFFF	
	: ·	: ·	: ·	: ·	: ·	: ·	: ·	
	32	23	080000-087FFF	23	080000-087FFF	23	080000-087FFF	
One Partition	32	22	078000-07FFFF	22	078000-07FFFF	22	078000-07FFFF	
	: ·	: ·	: ·	: ·	: ·	: ·	: ·	
	32	15	040000-047FFF	15	040000-047FFF	15	040000-047FFF	
Parameter	One Partition	32	14	038000-03FFFF	14	038000-03FFFF	14	038000-03FFFF
		: ·	: ·	: ·	: ·	: ·	: ·	
		32	8	008000-00FFFF	8	008000-00FFFF	8	008000-00FFFF
		4	7	007000-007FFF	7	007000-007FFF	7	007000-007FFF
		: ·	: ·	: ·	: ·	: ·	: ·	
4	0	000000-000FFF	0	000000-000FFF	0	000000-000FFF		

128 Mbit is not available at 90 nm.

Table 4: Top Parameter Memory Map

		Size (KW)	Blk #	32-Mbit	Blk #	64-Mbit	Blk #	128-Mbit
Parameter Partition	One Partition	4	70	1FF000-1FFFFF	134	3FF000-3FFFFF	262	7FF000-7FFFFF
		: ·	: ·	: ·	: ·	: ·	: ·	: ·
		4	63	1F8000-1F8FFF	127	3F8000-3F8FFF	255	7F8000-7F8FFF
		32	62	1F0000-1F7FFF	126	3F0000-3F7FFF	254	7F0000-7F7FFF
		: ·	: ·	: ·	: ·	: ·	: ·	: ·
		32	56	1C0000-1C7FFF	120	3C0000-3C7FFF	248	7C0000-7C7FFF
Main Partitions	One Partition	32	55	1B8000-1BFFFF	119	3B8000-3BFFFF	247	7B8000-7BFFFF
		: ·	: ·	: ·	: ·	: ·	: ·	
		32	48	18000-187FFF	112	380000-387FFF	240	780000-787FFF
	One Partition	32	47	178000-17FFFF	111	378000-37FFFF	239	778000-77FFFF
		: ·	: ·	: ·	: ·	: ·	: ·	
		32	40	140000-147FFF	104	340000-347FFF	232	740000-747FFF
	One Partition	32	39	138000-13FFFF	103	338000-33FFFF	231	738000-73FFFF
		: ·	: ·	: ·	: ·	: ·	: ·	
		32	32	100000-107FFF	96	300000-307FFF	224	700000-707FFF
	Four Partitions	32	31	0F8000-0FFFFF	95	2F8000-2FFFFF	223	6F8000-6FFFFF
		: ·	: ·	: ·	: ·	: ·	: ·	
		32	0	000000-007FFF	64	200000-207FFF	192	600000-607FFF
	Eight Partitions	32			63	1F8000-1FFFFF	191	5F8000-5FFFFF
		: ·			: ·	: ·	: ·	: ·
		32			0	000000-007FFF	128	400000-407FFF
	Sixteen Partitions	32					127	3F8000-3FFFFF
		: ·					: ·	: ·
		32					0	000000-007FFF

128 Mbit is not available at 90 nm.

3.0 Package Information

3.1 W18 – 90 nm Lithography

Figure 1: 32- and 64-Mbit VF BGA Package Drawing

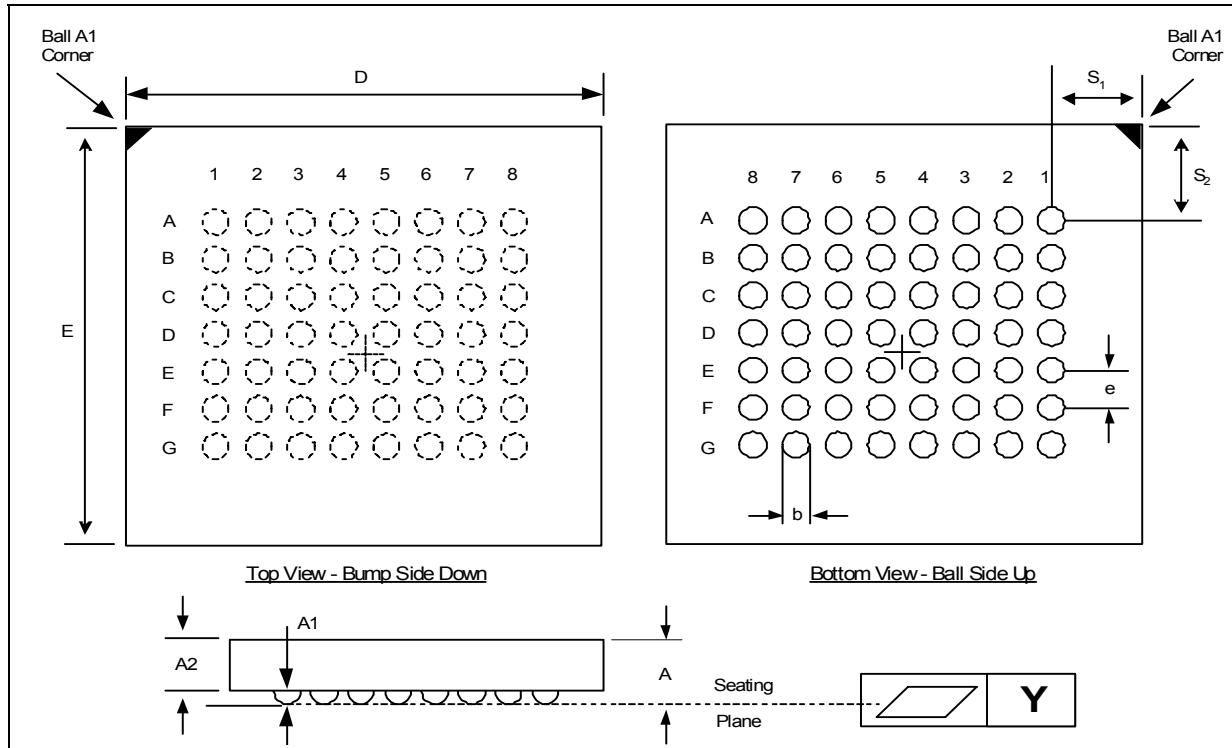

Table 5: 32- and 64-Mbit VF BGA Package Dimensions

Dimension	Symbol	Millimeters			Inches		
		Min	Nom	Max	Min	Nom	Max
Package Height	A	-	-	1.000	-	-	0.0394
Ball Height	A ₁	0.150	-	-	0.0059	-	-
Package Body Thickness	A ₂	-	0.665	-	-	0.0262	-
Ball (Lead) Width	b	0.325	0.375	0.425	0.0128	0.0148	0.0167
Package Body Width	D	7.600	7.700	7.800	0.2992	0.3031	0.3071
Package Body Length	E	8.900	9.000	9.100	0.3504	0.3543	0.3583
Pitch	[e]	-	0.750	-	-	0.0295	-
Ball (Lead) Count	N	-	56	-	-	56	-
Seating Plane Coplanarity	Y	-	-	0.100	-	-	0.0039
Corner to Ball A1 Distance Along D	S ₁	1.125	1.225	1.325	0.0443	0.0482	0.0522
Corner to Ball A1 Distance Along E	S ₂	2.150	2.250	2.350	0.0846	0.0886	0.0925

3.2 W18 – 130 nm

Figure 2: 32-, 64-, and 128-Mbit VF BGA Package Drawing

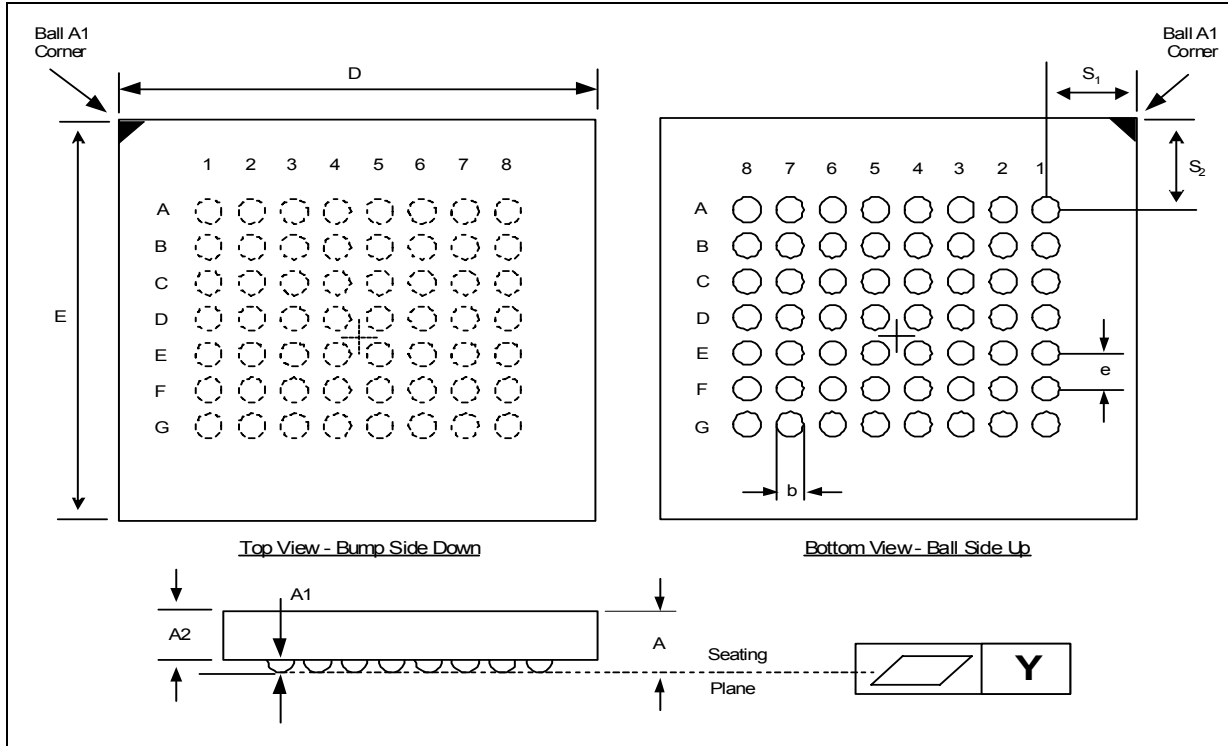
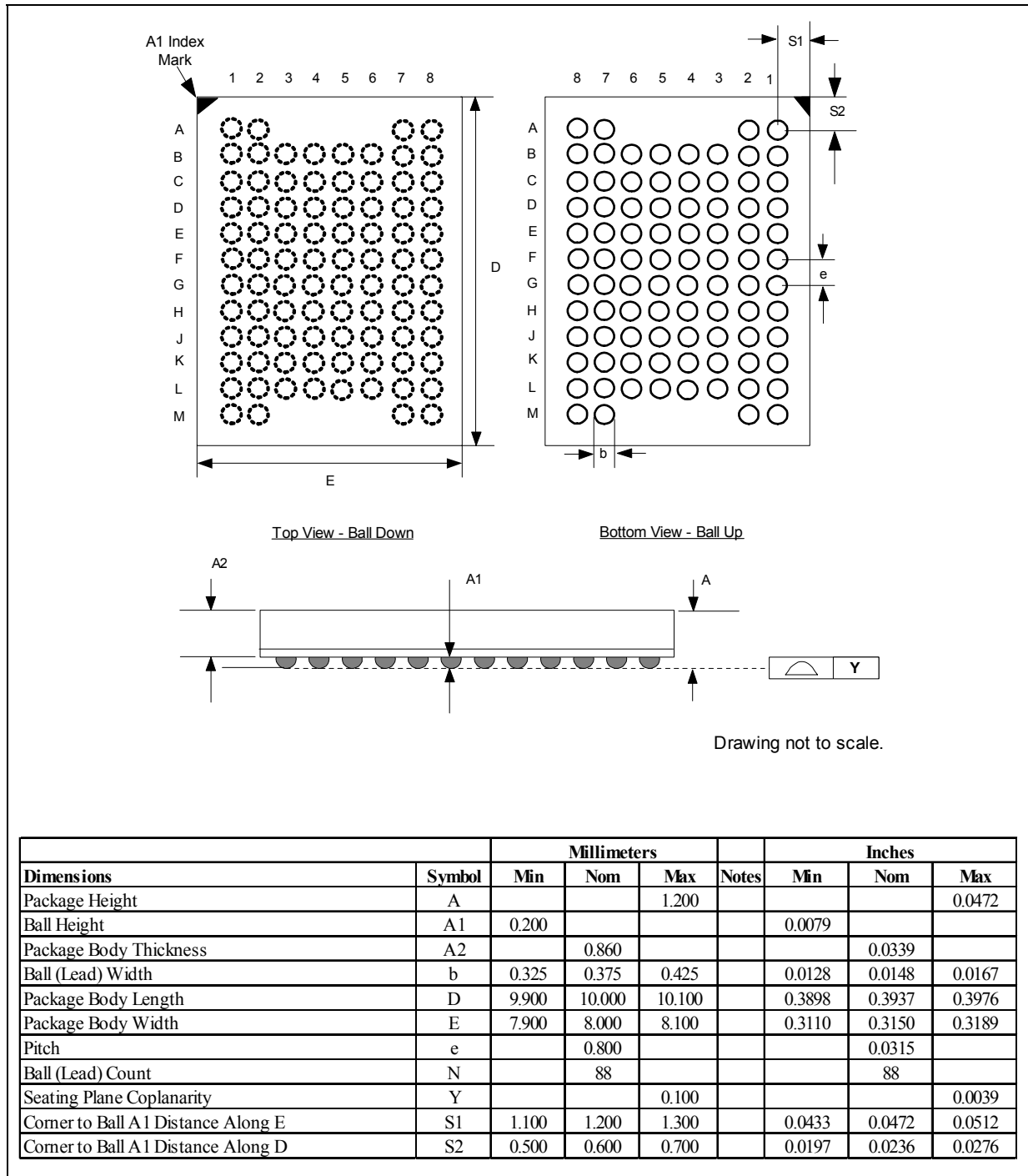

Table 6: 32-, 64-, and 128-Mbit VF BGA Package Dimensions

Dimension	Symbol	Millimeters			Inches		
		Min	Nom	Max	Min	Nom	Max
Package Height	A	-	-	1.000	-	-	0.0394
Ball Height	A ₁	0.150	-	-	0.0059	-	-
Package Body Thickness	A ₂	-	0.665	-	-	0.0262	-
Ball (Lead) Width	b	0.325	0.375	0.425	0.0128	0.0148	0.0167
Package Body Width (32/64-Mbit)	D	7.600	7.700	7.800	0.2992	0.3031	0.3071
Package Body Width (128-Mbit)	D	10.900	11.000	11.100	0.4291	0.4331	0.4370
Package Body Length (32/64/128-Mbit)	E	8.900	9.000	9.100	0.3504	0.3543	0.3583
Pitch	[e]	-	0.750	-	-	0.0295	-
Ball (Lead) Count	N	-	56	-	-	56	-
Seating Plane Coplanarity	Y	-	-	0.100	-	-	0.0039
Corner to Ball A1 Distance Along D (32/64-Mbit)	S ₁	1.125	1.225	1.325	0.0443	0.0482	0.0522
Corner to Ball A1 Distance Along D (128-Mbit)	S ₁	2.775	2.2875	2.975	0.1093	0.1132	0.1171
Corner to Ball A1 Distance Along E (32/64/128-Mbit)	S ₂	2.150	2.250	2.350	0.0846	0.0886	0.0925

Figure 3: 128-Mbit QUAD+ Package Drawing



4.0 Ballout and Signal Descriptions

4.1 Signal Ballout

The W18 device is available in a 56-ball VF BGA and μ BGA Chip Scale Package with 0.75 mm ball pitch, or the 88-ball (80 active balls) QUAD+ SCSP package. [Figure 4](#) shows the device ballout for the VF BGA package. [Figure 5](#) shows the device ballout for the QUAD+ package.

Figure 4: 56-Ball VF BGA Ballout

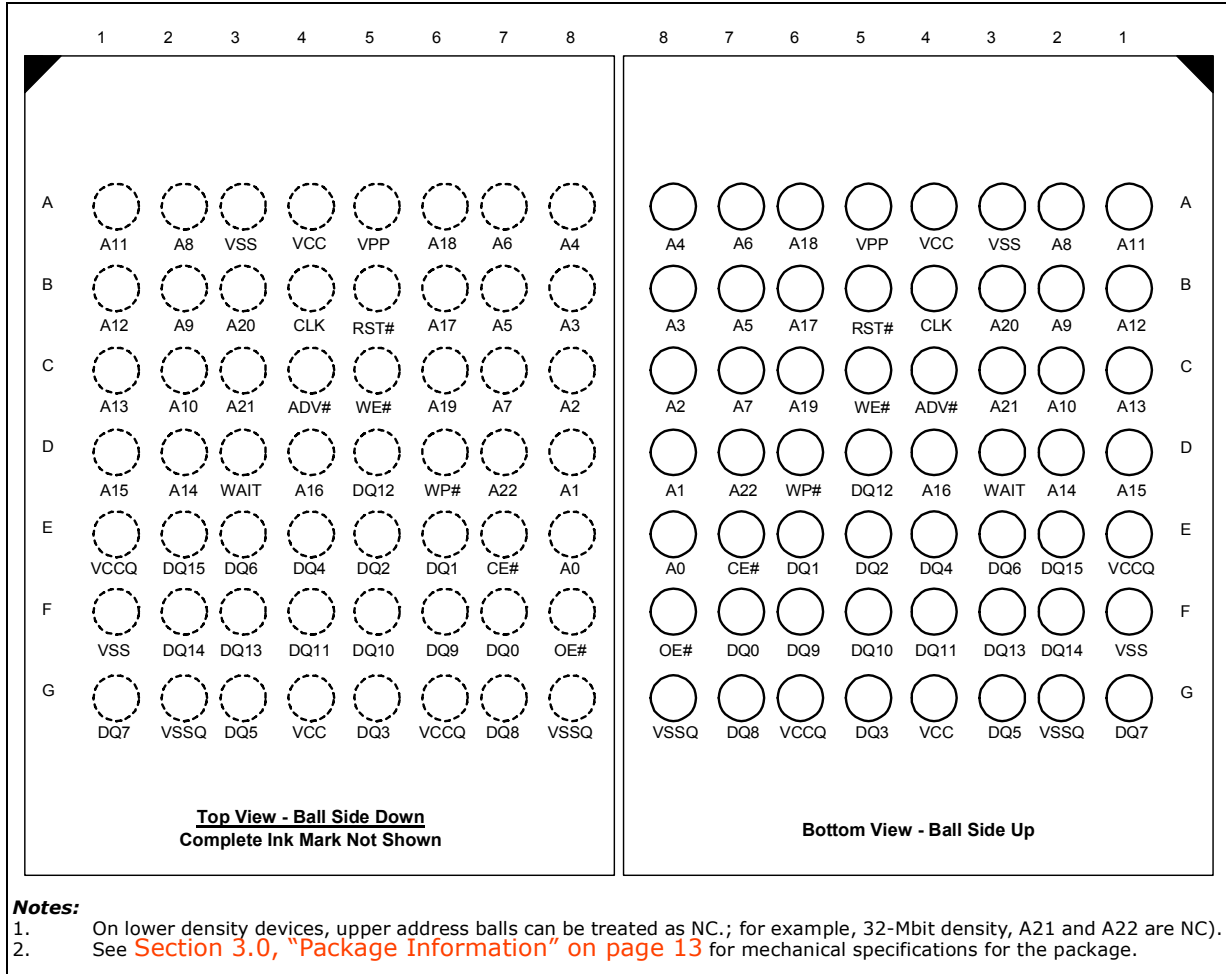
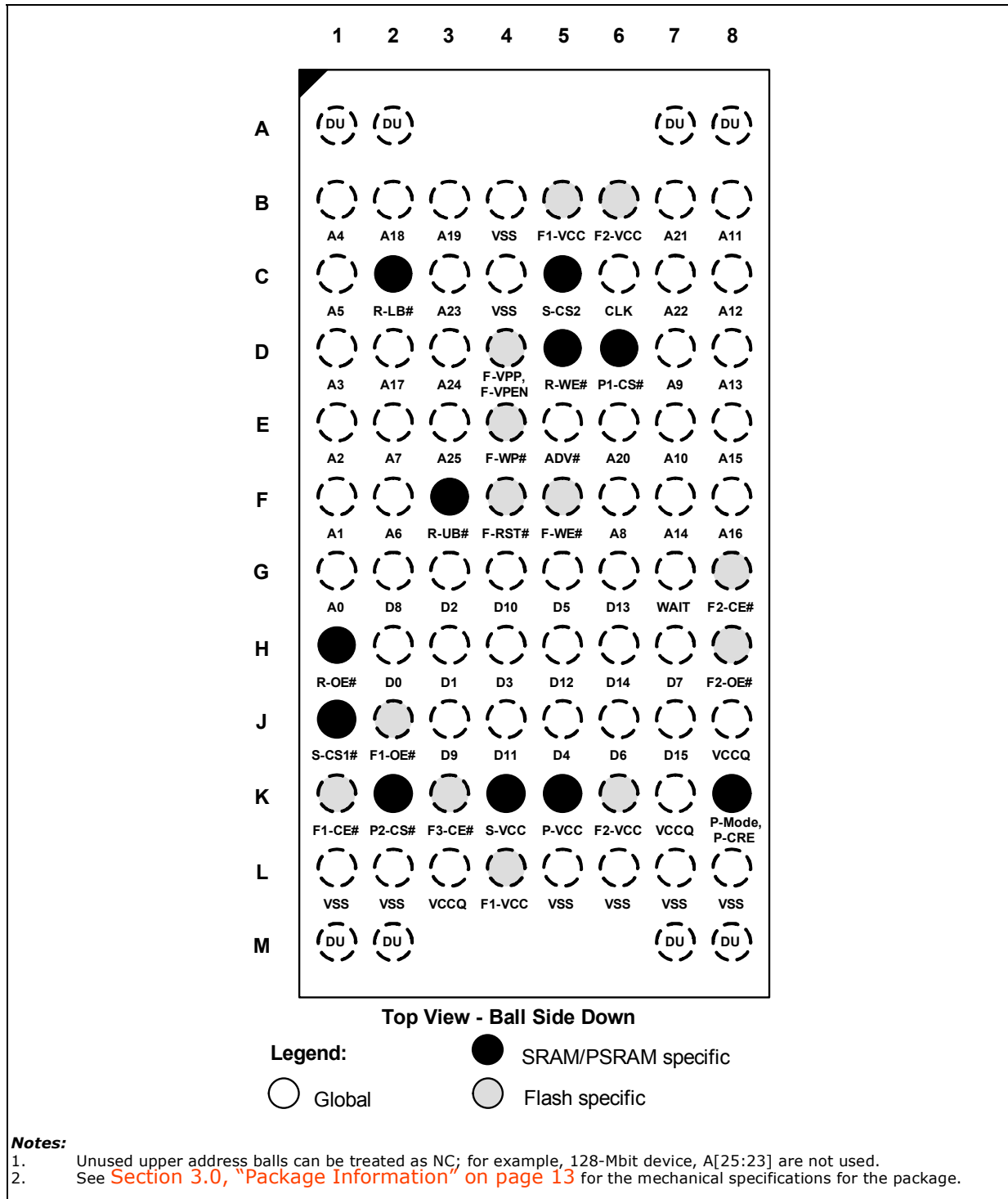

Figure 5: 88-Ball (80 Active Balls) QUAD+ Ballout



4.2 Signal Descriptions

Table 7 describes the signals used on the VF BGA package. Table 8 describes the signals used on the QUAD+ package.

Table 7: Signal Descriptions - VF BGA Package

Symbol	Type	Name and Function
A[22:0]	Input	ADDRESS INPUTS: For memory addresses. 32-Mbit: A[20:0]; 64-Mbit: A[21:0]; 128-Mbit: A[22:0]
D[15:0]	Input/Output	DATA INPUTS/OUTPUTS: Inputs data and commands during write cycles; outputs data during memory, Status Register, protection register, and configuration code reads. Data pins float when the chip or outputs are deselected. Data is internally latched during writes.
ADV#	Input	ADDRESS VALID: ADV# indicates valid address presence on address inputs. During synchronous read operations, all addresses are latched on ADV#'s rising edge or the next valid CLK edge with ADV# low, whichever occurs first.
CE#	Input	CHIP ENABLE: Asserting CE# activates internal control logic, I/O buffers, decoders, and sense amps. De-asserting CE# deselected the device, places it in standby mode, and places all outputs in High-Z.
CLK	Input	CLOCK: CLK synchronizes the device to the system bus frequency during synchronous reads and increments an internal address generator. During synchronous read operations, addresses are latched on ADV#'s rising edge or the next valid CLK edge with ADV# low, whichever occurs first.
OE#	Input	OUTPUT ENABLE: When asserted, OE# enables the device's output data buffers during a read cycle. When OE# is deasserted, data outputs are placed in a high-impedance state.
RST#	Input	RESET: When low, RST# resets internal automation and inhibits write operations. This provides data protection during power transitions. de-asserting RST# enables normal operation and places the device in asynchronous read-array mode.
WAIT	Output	WAIT: The WAIT signal indicates valid data during synchronous read modes. It can be configured to be asserted-high or asserted-low based on bit 10 of the Read Configuration Register. WAIT is tri-stated if CE# is deasserted. WAIT is not gated by OE#.
WE#	Input	WRITE ENABLE: WE# controls writes to the CUI and array. Addresses and data are latched on the rising edge of WE#.
WP#	Input	WRITE PROTECT: Disables/enables the lock-down function. When WP# is asserted, the lock-down mechanism is enabled and blocks marked lock-down cannot be unlocked through software. See Section 13.1, "Block Lock Operations" on page 71 for details on block locking.
VPP	Power	ERASE AND PROGRAM POWER: A valid voltage on this pin allows erasing or programming. Memory contents cannot be altered when $V_{PP} \leq V_{PPLK}$. Block erase and program at invalid V_{PP} voltages should not be attempted. Set $V_{PP} = V_{CC}$ for in-system program and erase operations. To accommodate resistor or diode drops from the system supply, the V_{IH} level of V_{PP} can be as low as V_{PP1} min. V_{PP} must remain above V_{PP1} min to perform in-system flash modification. VPP may be 0 V during read operations. V_{PP2} can be applied to main blocks for 1000 cycles maximum and to parameter blocks for 2500 cycles. VPP can be connected to 12 V for a cumulative total not to exceed 80 hours. Extended use of this pin at 12 V may reduce block cycling capability.
VCC	Power	DEVICE POWER SUPPLY: Writes are inhibited at $V_{CC} \leq V_{LKO}$. Device operations at invalid V_{CC} voltages should not be attempted.
VCCQ	Power	OUTPUT POWER SUPPLY: Enables all outputs to be driven at V_{CCQ} . This input may be tied directly to VCC.
VSS	Power	GROUND: Pins for all internal device circuitry must be connected to system ground.
VSSQ	Power	OUTPUT GROUND: Provides ground to all outputs which are driven by VCCQ. This signal may be tied directly to VSS.
DU	—	DO NOT USE: Do not use this pin. This pin should not be connected to any power supplies, signals or other pins and must be floated.
NC	—	NO CONNECT: No internal connection; can be driven or floated.

Table 8: Signal Descriptions - QUAD+ Package (Sheet 1 of 2)

Symbol	Type	Description
A[MAX:MIN]	Input	<p>ADDRESS INPUTS: Inputs for all die addresses during read and write operations.</p> <ul style="list-style-type: none"> —256-Mbit Die : AMAX= A23 —128-Mbit Die : AMAX = A22 —64-Mbit Die : AMAX = A21 —32-Mbit Die : AMAX = A20 —8-Mbit Die : AMAX = A18 <p>A0 is the lowest-order 16-bit wide address. A[25:24] denote high-order addresses reserved for future device densities.</p>
D[15:0]	Input/Output	<p>DATA INPUTS/OUTPUTS: Inputs data and commands during write cycles, outputs data during read cycles. Data signals float when the device or its outputs are deselected. Data are internally latched during writes on the flash device.</p>
F[3:1]-CE#	Input	<p>FLASH CHIP ENABLE: Low-true input.</p> <p>F[3:1]-CE# low selects the associated flash memory die. When asserted, flash internal control logic, input buffers, decoders, and sense amplifiers are active. When deasserted, the associated flash die is deselected, power is reduced to standby levels, data and WAIT outputs are placed in high-Z state.</p> <p>F1-CE# selects or deselected flash die #1; F2-CE# selects or deselected flash die #2 and is RFU on combinations with only one flash die. F3-CE# selects or deselected flash die #3 and is RFU on stacked combinations with only one or two flash dies.</p>
S-CS1# S-CS2	Input	<p>SRAM CHIP SELECT: Low-true / High-true input (S-CS1# / S-CS2 respectively).</p> <p>When either/both SRAM Chip Select signals are asserted, SRAM internal control logic, input buffers, decoders, and sense amplifiers are active. When either/both SRAM Chip Select signals are deasserted, the SRAM is deselected and its power is reduced to standby levels.</p> <p>S-CS1# and S-CS2 are available on stacked combinations with SRAM die and are RFU on stacked combinations without SRAM die.</p>
P[2:1]-CS#	Input	<p>PSRAM CHIP SELECT: Low-true input.</p> <p>When asserted, PSRAM internal control logic, input buffers, decoders, and sense amplifiers are active. When deasserted, the PSRAM is deselected and its power is reduced to standby levels.</p> <p>P1-CS# selects PSRAM die #1 and is available only on stacked combinations with PSRAM die. This ball is an RFU on stacked combinations without PSRAM. P2-CS# selects PSRAM die #2 and is available only on stacked combinations with two PSRAM dies. This ball is an RFU on stacked combinations without PSRAM or with a single PSRAM.</p>
F[2:1]-OE#	Input	<p>FLASH OUTPUT ENABLE: Low-true input.</p> <p>Fx-OE# low enables the selected flash's output buffers. F[2:1]-OE# high disables the selected flash's output buffers, placing them in High-Z.</p> <p>F1-OE# controls the outputs of flash die #1; F2-OE# controls the outputs of flash die #2 and flash die #3. F2-OE# is available on stacked combinations with two or three flash die and is RFU on stacked combinations with only one flash die.</p>
R-OE#	Input	<p>RAM OUTPUT ENABLE: Low-true input.</p> <p>R-OE# low enables the selected RAM's output buffers. R-OE# high disables the RAM output buffers, and places the selected RAM outputs in High-Z.</p> <p>R-OE# is available on stacked combinations with PSRAM or SRAM die, and is an RFU on flash-only stacked combinations.</p>
F-WE#	Input	<p>FLASH WRITE ENABLE: Low-true input.</p> <p>F-WE# controls writes to the selected flash die. Address and data are latched on the rising edge of F-WE#.</p>
R-WE#	Input	<p>RAM WRITE ENABLE: Low-true input.</p> <p>R-WE# controls writes to the selected RAM die.</p> <p>R-WE# is available on stacked combinations with PSRAM or SRAM die and is an RFU on flash-only stacked combinations.</p>
CLK	Input	<p>CLOCK: Synchronizes the flash die with the system bus clock in synchronous read mode and increments the internal address generator.</p> <p>During synchronous read operations, addresses are latched on the rising edge of ADV#, or on the next valid CLK edge with ADV# low, whichever occurs first.</p> <p>In asynchronous mode, addresses are latched on the rising edge ADV#, or are continuously flow-through when ADV# is kept asserted.</p>

Table 8: Signal Descriptions - QUAD+ Package (Sheet 2 of 2)

WAIT	Output	<p>WAIT: Output signal. Indicates invalid data during synchronous array or non-array flash reads. Read Configuration Register bit 10 (RCR[10]) determines WAIT-asserted polarity (high or low). WAIT is High-Z if F-CE# is deasserted; WAIT is not gated by F-OE#.</p> <ul style="list-style-type: none"> In synchronous array or non-array flash read modes, WAIT indicates invalid data when asserted and valid data when deasserted. In asynchronous flash page read, and all flash write modes, WAIT is asserted.
F-WP#	Input	<p>FLASH WRITE PROTECT: Low-true input. F-WP# enables/disables the lock-down protection mechanism of the selected flash die.</p> <ul style="list-style-type: none"> F-WP# low enables the lock-down mechanism where locked down blocks cannot be unlocked with software commands. F-WP# high disables the lock-down mechanism, allowing locked down blocks to be unlocked with software commands.
ADV#	Input	<p>ADDRESS VALID: Low-true input. During synchronous flash read operations, addresses are latched on the rising edge of ADV#, or on the next valid CLK edge with ADV# low, whichever occurs first. In asynchronous flash read operations, addresses are latched on the rising edge of ADV#, or are continuously flow-through when ADV# is kept asserted.</p>
R-UB# R-LB#	Input	<p>RAM UPPER / LOWER BYTE ENABLES: Low-true input. During RAM read and write cycles, R-UB# low enables the RAM high order bytes on D[15:8], and R-LB# low enables the RAM low-order bytes on D[7:0]. R-UB# and R-LB# are available on stacked combinations with PSRAM or SRAM die and are RFU on flash-only stacked combinations.</p>
F-RST#	Input	<p>FLASH RESET: Low-true input. F-RST# low initializes flash internal circuitry and disables flash operations. F-RST# high enables flash operation. Exit from reset places the flash in asynchronous read array mode.</p>
P-Mode, P-CRE	Input	<p>P-Mode (PSRAM Mode): Low-true input. P-Mode is used to program the Configuration Register, and enter/exit Low Power Mode of PSRAM die. P-Mode is available on stacked combinations with asynchronous-only PSRAM die. P-CRE (PSRAM Configuration Register Enable): High-true input. P-CRE is high, write operations load the refresh control register or bus control register. P-CRE is applicable only on combinations with synchronous PSRAM die. P-Mode, P-CRE is an RFU on stacked combinations without PSRAM die.</p>
F-VPP, F-VPEN	Power	<p>FLASH PROGRAM AND ERASE POWER: Valid F-V_{pp} voltage on this ball enables flash program/erase operations. Flash memory array contents cannot be altered when F-V_{pp}(F-V_{PEN}) < V_{PPLK}(V_{PENLK}). Erase / program operations at invalid F-V_{pp} (F-V_{PEN}) voltages should not be attempted. Refer to flash discrete product datasheet for additional details. F-VPEN (Erase/Program/Block Lock Enables) is not available for L18/L30 SCSP products.</p>
F[2:1]-VCC	Power	<p>FLASH LOGIC POWER: F1-VCC supplies power to the core logic of flash die #1; F2-VCC supplies power to the core logic of flash die #2 and flash die #3. Write operations are inhibited when F-V_{CC} < V_{LKO}. Device operations at invalid F-V_{CC} voltages should not be attempted. F2-VCC is available on stacked combinations with two or three flash dies, and is an RFU on stacked combinations with only one flash die.</p>
S-VCC	Power	<p>SRAM POWER SUPPLY: Supplies power for SRAM operations. S-VCC is available on stacked combinations with SRAM die, and is RFU on stacked combinations without SRAM die.</p>
P-VCC	Power	<p>PSRAM POWER SUPPLY: Supplies power for PSRAM operations. P-VCC is available on stacked combinations with PSRAM die, and is RFU on stacked combinations without PSRAM die.</p>
VCCQ	Power	<p>DEVICE I/O POWER: Supply power for the device input and output buffers.</p>
VSS	Power	<p>DEVICE GROUND: Connect to system ground. Do not float any VSS connection.</p>
RFU	—	<p>RESERVED for FUTURE USE: Reserved for future device functionality/ enhancements. Contact Numonyx regarding the use of balls designated RFU.</p>
DU	—	<p>DO NOT USE: Do not connect to any other signal, or power supply; must be left floating.</p>

5.0 Maximum Ratings and Operating Conditions

5.1 Absolute Maximum Ratings

Warning: Stressing the device beyond the “Absolute Maximum Ratings” may cause permanent damage. These are stress ratings only.

Notice: This datasheet contains information on products in the design phase of development. The information here is subject to change without notice. Do not finalize a design with this information.

Table 9: Absolute Maximum Ratings

Parameter	Maximum Rating	Notes
Temperature under Bias	-40 °C to +85 °C	
Storage Temperature	-65 °C to +125 °C	
Voltage on Any Pin (except V _{CC} , V _{CCQ} , V _{PP})	-0.5 V to +2.45 V	1,2
V _{PP} Voltage	-0.2 V to +13.1 V	1,3,4
V _{CC} and V _{CCQ} Voltage	-0.2 V to +2.45 V	1,2
Output Short Circuit Current	100 mA	5

Notes:

1. Specified voltages are with respect to V_{SS}.
2. During transitions, this level may:
 - (130 nm) Undershoot -2.0 V for periods < 20 ns and overshoot to V_{CCQ} +2.0 V for periods < 20 ns
 - (90 nm) Undershoot -1.0 V for periods < 20 ns and overshoot to V_{CCQ} +1.0 V for periods < 20 ns.
3. Maximum DC voltage on V_{PP} may overshoot to +14.6 V for periods < 20 ns.
4. V_{PP} program voltage is normally V_{PP1}. V_{PP} can be 12 V ± 0.6 V for 1000 cycles on the main blocks and 2500 cycles on the parameter blocks during program/erase.
5. Output shorted for no more than one second. No more than one output shorted at a time.

5.2 Operating Conditions

Warning: Operation beyond the “Operating Conditions” is not recommended and extended exposure beyond the “Operating Conditions” may affect device reliability.

Table 10: Extended Temperature Operation (Sheet 1 of 2)

Symbol	Parameter ¹	Min	Nom	Max	Unit	Note	
T _A	Operating Temperature	-40	25	85	°C		
V _{CC}	V _{CC} Supply Voltage	1.7	1.8	1.95	V	2	
	I/O Supply Voltage (90 nm)	1.7	1.8	1.95		2	
V _{CCQ}	I/O Supply Voltage (130 nm)	1.7	1.8	2.24		2	
V _{PP1}	V _{PP} Voltage Supply (Logic Level)	0.90	1.80	1.95		1	
V _{PP2}	Factory Programming V _{PP}	11.4	12.0	12.6		1	
t _{PPH}	Maximum V _{PP} Hours	V _{PP} = 12 V		-	80	Hours	1

Table 10: Extended Temperature Operation (Sheet 2 of 2)

Symbol	Parameter ¹		Min	Nom	Max	Unit	Note
Block Erase Cycles	Main and Parameter Blocks	$V_{PP} \leq V_{CC}$	100,000	-	-	Cycles	1
	Main Blocks	$V_{PP} = 12\text{ V}$	-	-	1000		1
	Parameter Blocks	$V_{PP} = 12\text{ V}$	-	-	2500		1

Notes:

1. VPP is normally V_{PP1} . VPP can be connected to 11.4 V–12.6 V for 1000 cycles on main blocks at extended temperatures and 2500 cycles on parameter blocks at extended temperatures.
2. Contact your Numonyx field representative for V_{CC}/V_{CCQ} operations down to 1.65 V.

6.0 Electrical Specifications

6.1 DC Current Characteristics

Note: Specifications are for 130 nm and 90 nm devices unless otherwise stated; the 128 Mbit density is supported ONLY on 90 nm.

Table 11: DC Current Characteristics (Sheet 1 of 2)

Symbol	Parameter ⁽¹⁾		V _{CCQ} = 1.8 V				Unit	Test Condition	Note
			32/64-Mbit		128-Mbit				
			Typ	Max	Typ	Max			
I _{LI}	Input Load		—	±1	—	±1	μA	V _{CC} = V _{CCMax} V _{CCQ} = V _{CCQMax} V _{IN} = V _{CCQ} or GND	8
I _{LO}	Output Leakage	D[15:0]	—	±1	—	±1	μA	V _{CC} = V _{CCMax} V _{CCQ} = V _{CCQMax} V _{IN} = V _{CCQ} or GND	
130 nm I _{CCS}	V _{CC} Standby		8	50	8	70	μA	V _{CC} = V _{CCMax} V _{CCQ} = V _{CCQMax} CE# = V _{CC} RST# = V _{CCQ}	9
90 nm I _{CCS}			22	50	—	—			
130 nm I _{CCAPS}	APS		8	50	8	70	μA	V _{CC} = V _{CCMax} V _{CCQ} = V _{CCQMax} CE# = V _{SSQ} RST# = V _{CCQ} All other inputs = V _{CCQ} or V _{SSQ}	10
90 nm I _{CCAPS}			22	50	—	—			
I _{CCR}	Average V _{CC} Read	Asynchronous Page Mode f = 13 MHz	3	6	4	7	mA	4 Word Read	3
		Synchronous CLK = 40 MHz	6	13	6	13	mA	Burst length = 4	3
			8	14	8	14	mA	Burst length = 8	
			10	18	11	19	mA	Burst length = 16	
			11	20	11	20	mA	Burst length = Continuous	
		Synchronous CLK = 54 MHz	7	16	7	16	mA	Burst length = 4	3
			10	18	10	18	mA	Burst length = 8	
			12	22	12	22	mA	Burst length = 16	
I _{CCR}	Average V _{CC} Read	Synchronous CLK = 66 MHz	13	25	13	25	mA	Burst length = Continuous	3, 4
			8	17	—	—	mA	Burst length = 4	
			11	20	—	—	mA	Burst length = 8	
			14	25	—	—	mA	Burst length = 16	
I _{CCW}	V _{CC} Program		18	40	18	40	mA	V _{PP} = V _{PP1} , Program in Progress	4,5,6
			8	15	8	15	mA	V _{PP} = V _{PP2} , Program in Progress	
I _{CCE}	V _{CC} Block Erase		18	40	18	40	mA	V _{PP} = V _{PP1} , Block Erase in Progress	4,5,6
			8	15	8	15	mA	V _{PP} = V _{PP2} , Block Erase in Progress	

Table 11: DC Current Characteristics (Sheet 2 of 2)

Symbol	Parameter ⁽¹⁾	V _{CCQ} = 1.8 V				Unit	Test Condition	Note
		32/64-Mbit		128-Mbit				
		Typ	Max	Typ	Max			
130nm I _{CCWS}	V _{CC} Program Suspend	8	50	5	25	μA	CE# = V _{CC} , Program Suspended	7
90nm I _{CCWS}		22	50	—	—	μA		
130nm I _{CCES}	V _{CC} Erase Suspend	8	50	5	25	μA	CE# = V _{CC} , Erase Suspended	7
90nm I _{CCWS}		22	50	—	—	μA		
I _{PPS} (I _{PPWS} , I _{PPES})	V _{PP} Standby V _{PP} Program Suspend V _{PP} Erase Suspend	0.2	5	0.2	5	μA	V _{PP} ≤ V _{CC}	4
I _{PPR}	V _{PP} Read	2	15	2	15	μA	V _{PP} ≤ V _{CC}	
I _{PPW}	V _{PP} Program	0.05	0.10	0.05	0.10	mA	V _{PP} = V _{PP1} , Program in Progress	5
		8	22	16	37		V _{PP} = V _{PP2} , Program in Progress	
I _{PPE}	V _{PP} Erase	0.05	0.10	0.05	0.10	mA	V _{PP} = V _{PP1} , Erase in Progress	5
		8	22	8	22		V _{PP} = V _{PP2} , Erase in Progress	

Notes:

- All currents are RMS unless noted. Typical values at typical V_{CC}, T_A = +25° C.
- V_{CCQ} = 1.35 V - 1.8V is available on 130 nm products only.
- Automatic Power Savings (APS) reduces I_{CCR} to approximately standby levels in static operation. See I_{CCRQ} specification for details.
- Sampled, not 100% tested.
- V_{CC} read + program current is the sum of V_{CC} read and V_{CC} program currents.
- V_{CC} read + erase current is the sum of V_{CC} read and V_{CC} erase currents.
- I_{CCES} is specified with device deselected. If device is read while in erase suspend, current is I_{CCES} plus I_{CCR}.
- If V_{IN} > V_{CC} the input load current increases to 10 μA max.
- I_{CCS} is the average current measured over any 5 ms time interval 5 μs after a CE# de-assertion.
- Refer to section [Section 8.2, "Automatic Power Savings \(APS\)"](#) on page 46 for I_{CCAPS} measurement details.

6.2 DC Voltage Characteristics

Note: Specifications are for 130 nm and 90 nm devices unless otherwise stated; the 128 Mbit density is supported ONLY on 90 nm.

Table 12: DC Voltage Characteristics (Sheet 1 of 2)

Symbol	Parameter	V _{CCQ} = 1.8 V				Unit	Test Condition	Notes
		32/64-Mbit		128-Mbit				
		Min	Max	Min	Max			
V _{IL}	Input Low	0	0.4	0	0.4	V		2
V _{IH}	Input High	V _{CCQ} - 0.4	V _{CCQ}	V _{CCQ} - 0.4	V _{CCQ}	V		2
V _{OL}	Output Low	-	0.1	-	0.1	V	V _{CC} = V _{CCMin} V _{CCQ} = V _{CCQMin} I _{OL} = 100 μA	

Table 12: DC Voltage Characteristics (Sheet 2 of 2)

Symbol	Parameter	V _{CCQ} = 1.8 V				Unit	Test Condition	Notes
		32/64-Mbit		128-Mbit				
		Min	Max	Min	Max			
V _{OH}	Output High	V _{CCQ} - 0.1	-	V _{CCQ} - 0.1	-	V	V _{CC} = V _{CCMin} V _{CCQ} = V _{CCQMin} I _{OH} = -100 μA	
V _{PPLK}	V _{PP} Lock-Out	-	0.4	-	0.4	V		3
V _{LKO}	V _{CC} Lock (130nm)	1.0	-	1.0	-	V		4
	V _{CC} Lock (90nm)	0.7	-	-	-	V		
V _{ILKOQ}	V _{CCQ} Lock	0.9	-	0.9	-	V		

Notes:

1. V_{CCQ} = 1.35 V - 1.8V is available on 130 nm devices only.
2. V_{IL} can undershoot to -1.0 V for durations of 2 ns or less and V_{IH} can overshoot to V_{CCQ}+1.0 V for durations of 2 ns or less.
3. V_{PP} <= V_{PPLK} inhibits erase and program operations. Don't use V_{PPL} and V_{PPH} outside their valid ranges.
4. Block erases, programming and lock-bit configurations are inhibited when V_{CC}<V_{LKO}, and not guaranteed in the range between V_{LKMIN} and V_{CCMIN}, and above V_{CCMAX}.

7.0 AC Characteristics

Table 13: Read Operations — 90 nm (Sheet 1 of 2)

#	Symbol	Parameter ^(1,2)	$V_{CCQ} = 1.7\text{ V} - 1.95\text{ V}$		Unit	Notes
			Min	Max		
Asynchronous Specifications						
R1	t_{AVAV}	Read Cycle Time	60	-	ns	7,8
R2	t_{AVQV}	Address to Output Valid	-	60	ns	7,8
R3	t_{ELQV}	CE# Low to Output Valid	-	60	ns	7,8
R4	t_{GLQV}	OE# Low to Output Valid	-	20	ns	4
R5	t_{PHQV}	RST# High to Output Valid	-	150	ns	
R6	t_{ELQX}	CE# Low to Output Low-Z	0	-	ns	5
R7	t_{GLQX}	OE# Low to Output Low-Z	0	-	ns	4,5
R8	t_{EHQZ}	CE# High to Output High-Z	-	14	ns	5
R9	t_{GHQZ}	OE# High to Output High-Z	-	14	ns	4,5
R10	t_{OH}	CE# (OE#) High to Output Low-Z	0	-	ns	4,5
R11	t_{EHEL}	CE# Pulse Width High	14	-	ns	6
R12	t_{ELTV}	CE# Low to WAIT Valid	-	11	ns	6
R13	t_{EHTZ}	CE# High to WAIT High-Z	-	11	ns	5,6
Latching Specifications						
R101	t_{AVVH}	Address Setup to ADV# High	7	-	ns	
R102	t_{ELVH}	CE# Low to ADV# High	10	-	ns	
R103	t_{VLQV}	ADV# Low to Output Valid	-	60	ns	7,8
R104	t_{VLVH}	ADV# Pulse Width Low	7	-	ns	
R105	t_{VHVL}	ADV# Pulse Width High	7	-	ns	
R106	t_{VHAX}	Address Hold from ADV# High	7	-	ns	3
R108	t_{APA}	Page Address Access Time	-	20	ns	
Clock Specifications						
R200	f_{CLK}	CLK Frequency	-	66	MHz	
R201	t_{CLK}	CLK Period	15	-	ns	
R202	$t_{CH/L}$	CLK High or Low Time	3.5	-	ns	
R203	t_{CHCL}	CLK Fall or Rise Time	-	3	ns	

Table 13: Read Operations – 90 nm (Sheet 2 of 2)

#	Symbol	Parameter (1,2)	V _{CCQ} = 1.7 V – 1.95 V		Unit	Notes
			Min	Max		
Synchronous Specifications						
R301	t _{AVCH}	Address Valid Setup to CLK	7	-	ns	
R302	t _{VLCH}	ADV# Low Setup to CLK	7	-	ns	
R303	t _{ELCH}	CE# Low Setup to CLK	7	-	ns	
R304	t _{CHQV}	CLK to Output Valid	-	11	ns	8
R305	t _{CHQX}	Output Hold from CLK	3	-	ns	
R306	t _{CHAX}	Address Hold from CLK	7	-	ns	3
R307	t _{CHTV}	CLK to WAIT Valid	-	11	ns	8

Notes:

- See Figure 20, "AC Input/Output Reference Waveform" on page 44 for timing measurements and maximum allowable input slew rate.
- AC specifications assume the data bus voltage is less than or equal to V_{CCQ} when a read operation is initiated.
- Address hold in synchronous-burst mode is defined as t_{CHAX} or t_{VHAX}, whichever timing specification is satisfied first.
- OE# may be delayed by up to t_{ELQV} - t_{GLQV} after the falling edge of CE# without impact to t_{ELQV}.
- Sampled, not 100% tested.
- Applies only to subsequent synchronous reads.
- During the initial access of a synchronous burst read, data from the first word may begin to be driven onto the data bus as early as the first clock edge after t_{AVQV}.
- All the preceding specifications apply to all densities.

Table 14: Read Operations – 130 nm (Sheet 1 of 2)

#	Symbol	Parameter (1,2)	V _{CCQ} = 1.7 V – 2.24 V		Unit	Notes
			-60			
			Min	Max		
Asynchronous Specifications						
R1	t _{AVAV}	Read Cycle Time	60	-	ns	7,8
R2	t _{AVQV}	Address to Output Valid	-	60	ns	7,8
R3	t _{ELQV}	CE# Low to Output Valid	-	60	ns	7,8
R4	t _{GLQV}	OE# Low to Output Valid	-	20	ns	4
R5	t _{PHQV}	RST# High to Output Valid	-	150	ns	
R6	t _{ELQX}	CE# Low to Output Low-Z	0	-	ns	5
R7	t _{GLQX}	OE# Low to Output Low-Z	0	-	ns	4,5
R8	t _{EHQZ}	CE# High to Output High-Z	-	14	ns	5
R9	t _{GHQZ}	OE# High to Output High-Z	-	14	ns	4,5
R10	t _{OH}	CE# (OE#) High to Output Low-Z	0	-	ns	4,5
R11	t _{EHEL}	CE# Pulse Width High	-	14	ns	6
R12	t _{ELTV}	CE# Low to WAIT Valid	-	11	ns	5,6
R13	t _{EHTZ}	CE# High to WAIT High-Z	14	-	ns	6
Latching Specifications						

Table 14: Read Operations — 130 nm (Sheet 2 of 2)

#	Symbol	Parameter ^(1,2)	V _{CCQ} = 1.7 V – 2.24 V		Unit	Notes
			-60			
			Min	Max		
R101	t _{AVVH}	Address Setup to ADV# High	7	-	ns	
R102	t _{ELVH}	CE# Low to ADV# High	10	-	ns	
R103	t _{VLQV}	ADV# Low to Output Valid	-	60	ns	7,8
R104	t _{VLVH}	ADV# Pulse Width Low	7	-	ns	
R105	t _{VHVL}	ADV# Pulse Width High	7	-	ns	
R106	t _{VHAX}	Address Hold from ADV# High	7	-	ns	3
R108	t _{APA}	Page Address Access Time	-	20	ns	
Clock Specifications						
R200	f _{CLK}	CLK Frequency	-	66	MHz	
R201	t _{CLK}	CLK Period	15	-	ns	
R202	t _{CH/L}	CLK High or Low Time	3.5	-	ns	
R203	t _{CHCL}	CLK Fall or Rise Time	-	3	ns	
Synchronous Specifications						
R301	t _{AVCH}	Address Valid Setup to CLK	7	-	ns	
R302	t _{VLCH}	ADV# Low Setup to CLK	7	-	ns	
R303	t _{ELCH}	CE# Low Setup to CLK	7	-	ns	
R304	t _{CHQV}	CLK to Output Valid	-	11	ns	8
R305	t _{CHQX}	Output Hold from CLK	3	-	ns	
R306	t _{CHAX}	Address Hold from CLK	7	-	ns	3
R307	t _{CHTV}	CLK to WAIT Valid	-	11	ns	8

Note: For all numbered note references in this table, refer to the notes in [Table 13, "Read Operations — 90 nm"](#) on [page 26](#).

Figure 6: Asynchronous Read Operation Waveform

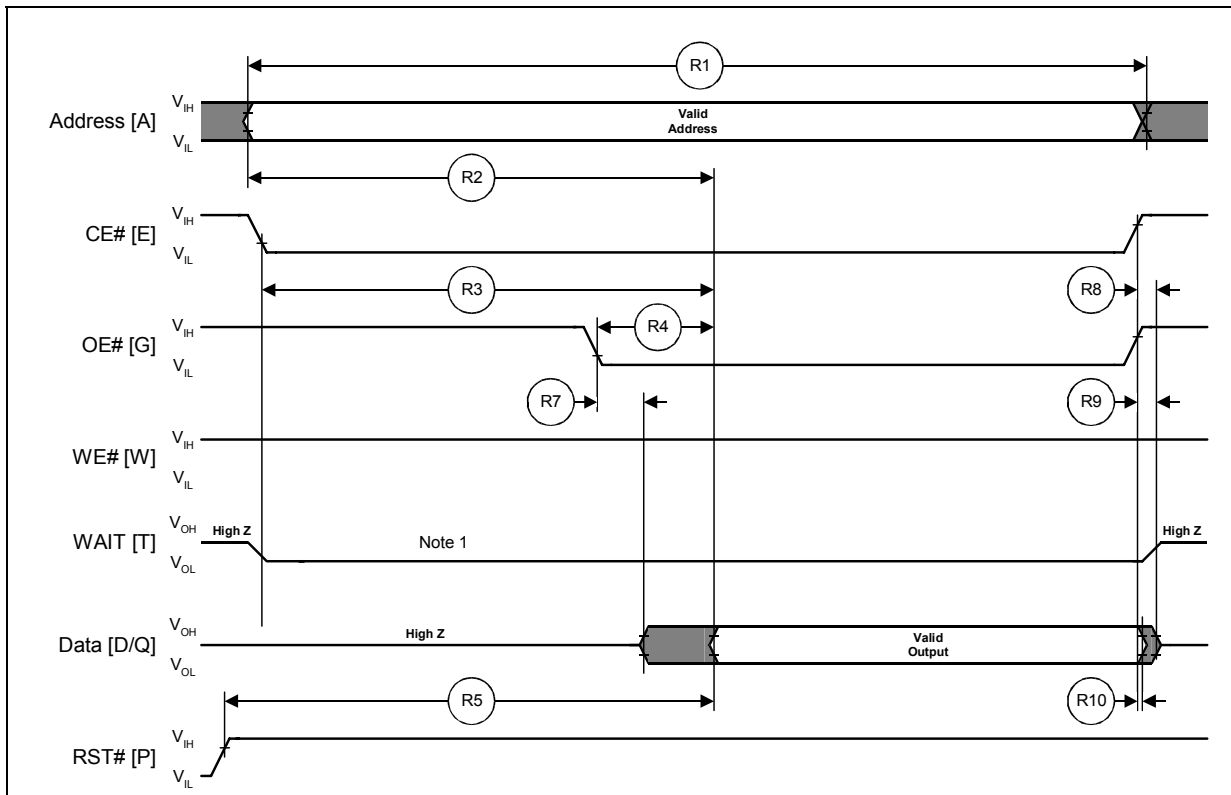

Notes:

1. WAIT shown asserted (RCR[10]=0)
2. ADV# assumed to be driven to VIL in this waveform

Figure 7: Latched Asynchronous Read Operation Waveform

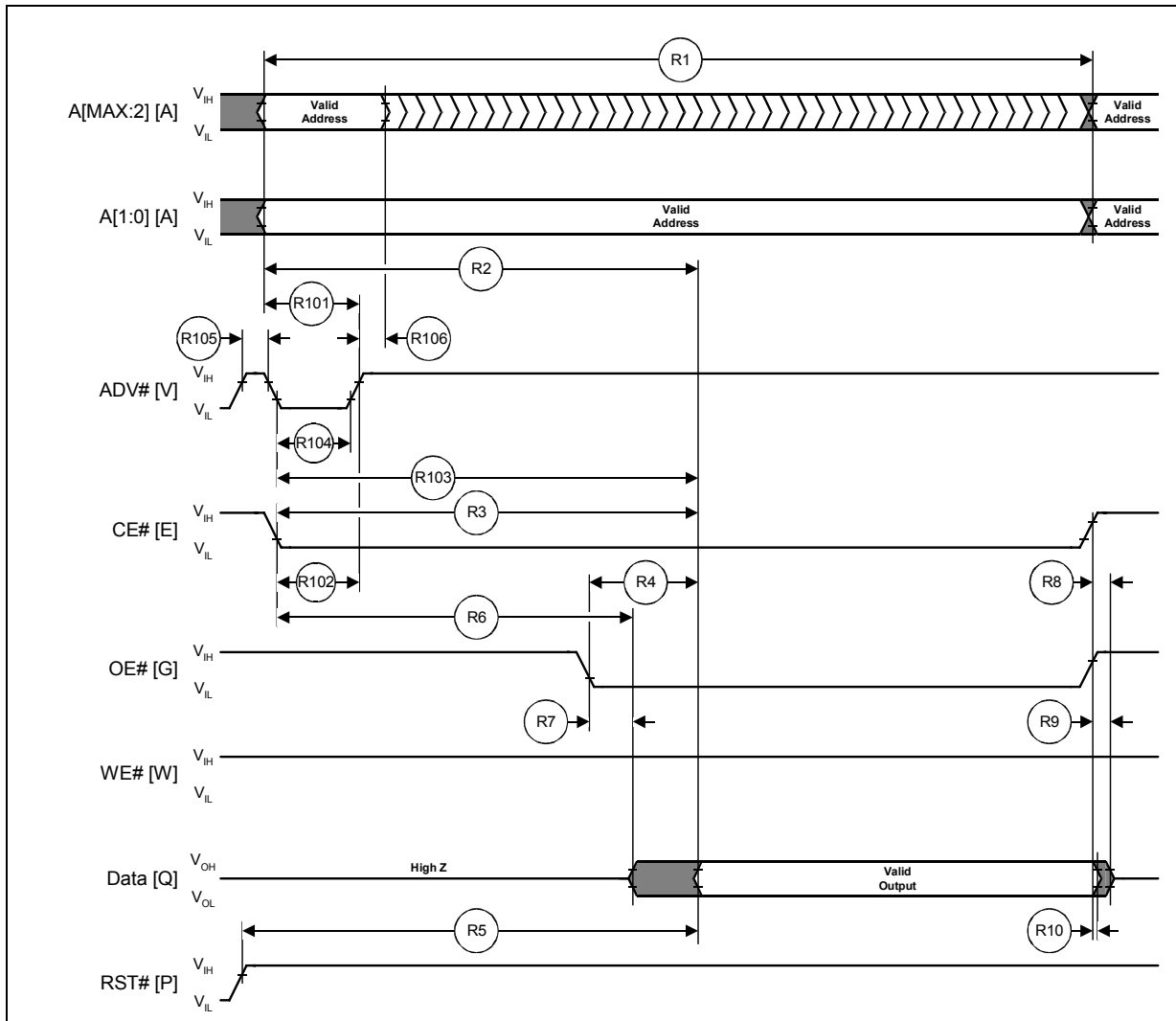
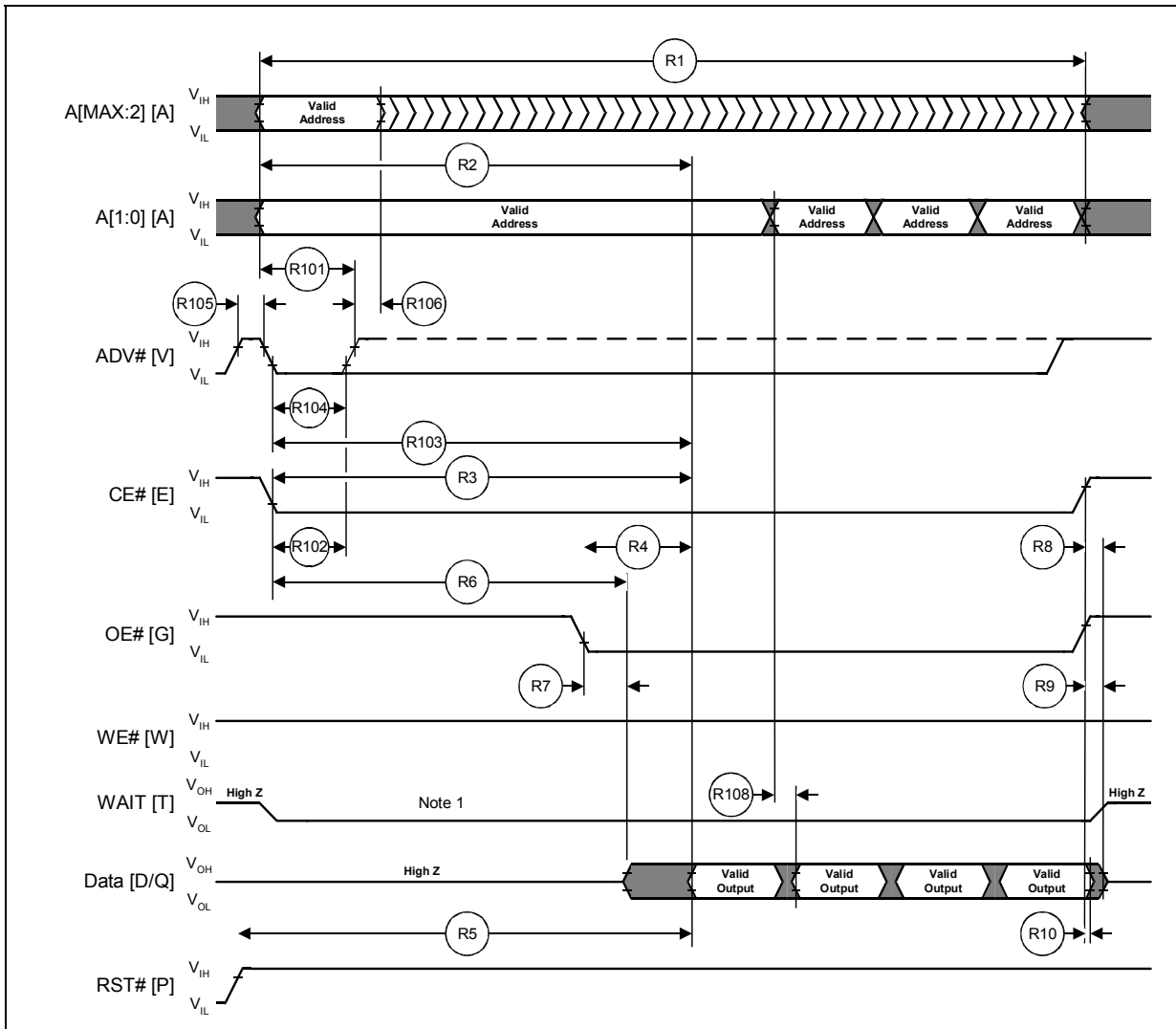
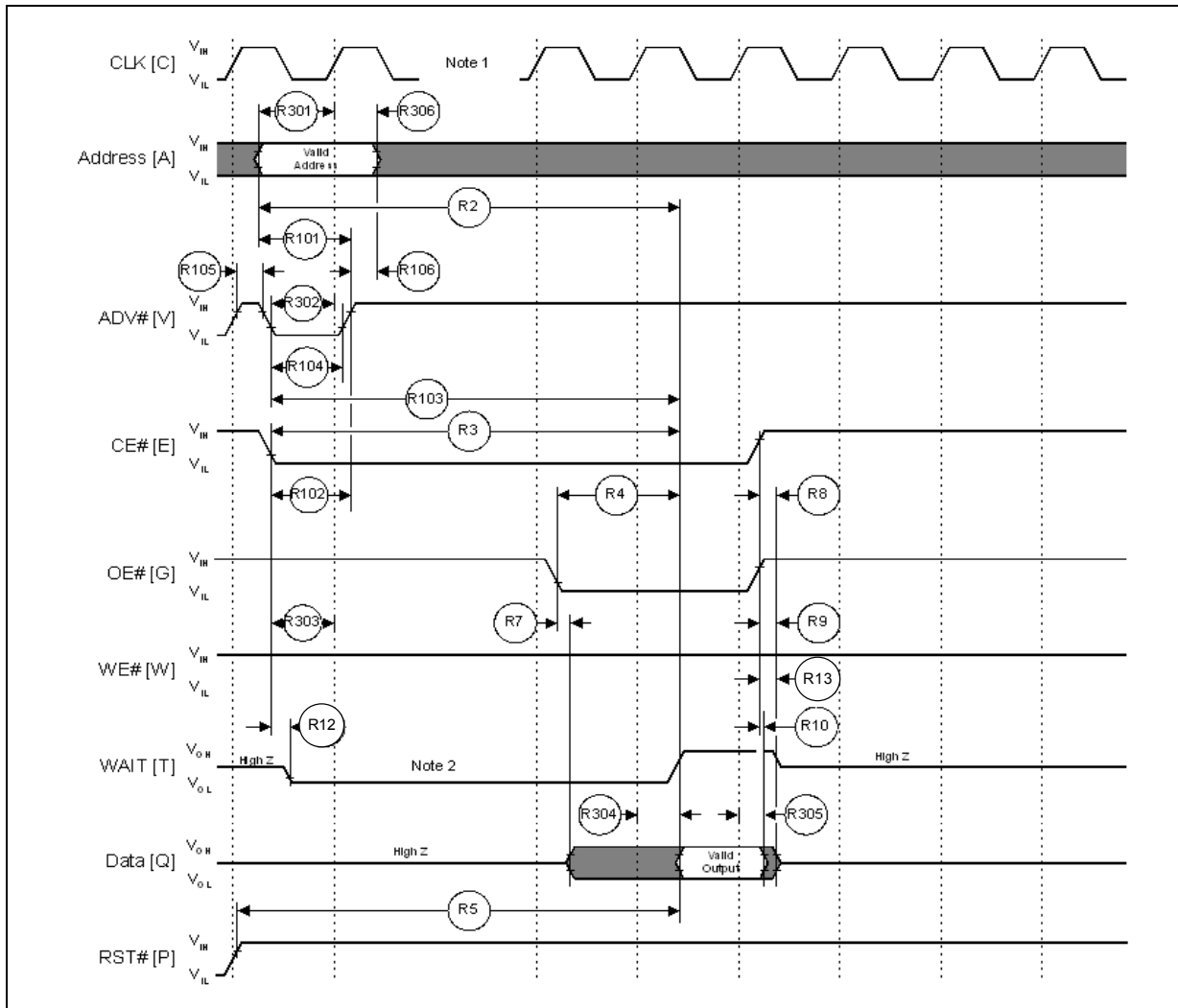

Figure 8: Page-Mode Read Operation Waveform



Note: WAIT shown asserted (RCR[10] = 0).

Figure 9: Single Synchronous Read-Array Operation Waveform



Notes:

1. Section 14.2, "First Access Latency Count (RCR[13:11])" on page 79 describes how to insert clock cycles during the initial access.
2. WAIT (shown asserted; RCR[10]=0) can be configured to assert either during, or one data cycle before, valid data.
3. This waveform illustrates the case in which an x-word burst is initiated to the main array and it is terminated by a CE# deassertion after the first word in the burst. If this access had been done to Status, ID, or Query reads, the asserted (low) WAIT signal would have remained asserted (low) as long as CE# is asserted (low).

Figure 10: Synchronous 4-Word Burst Read Operation Waveform

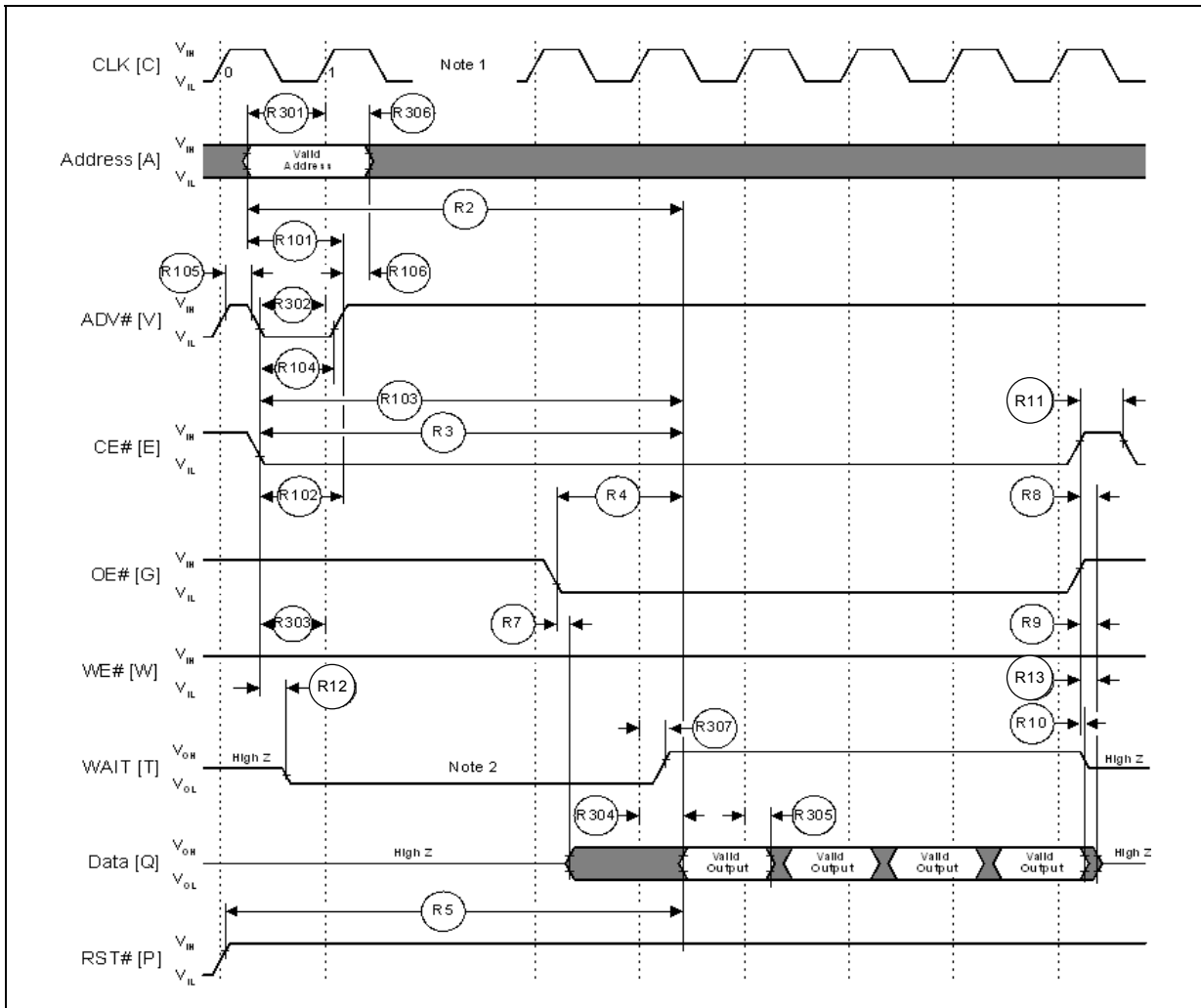

Notes:

1. Section 14.2, "First Access Latency Count (RCR[13:11])" on page 79 describes how to insert clock cycles during the initial access.
2. WAIT (shown asserted; RCR[10] = 0) can be configured to assert either during, or one data cycle before, valid data.

Figure 11: WAIT Functionality for EOWL (End-of-Word Line) Condition Waveform

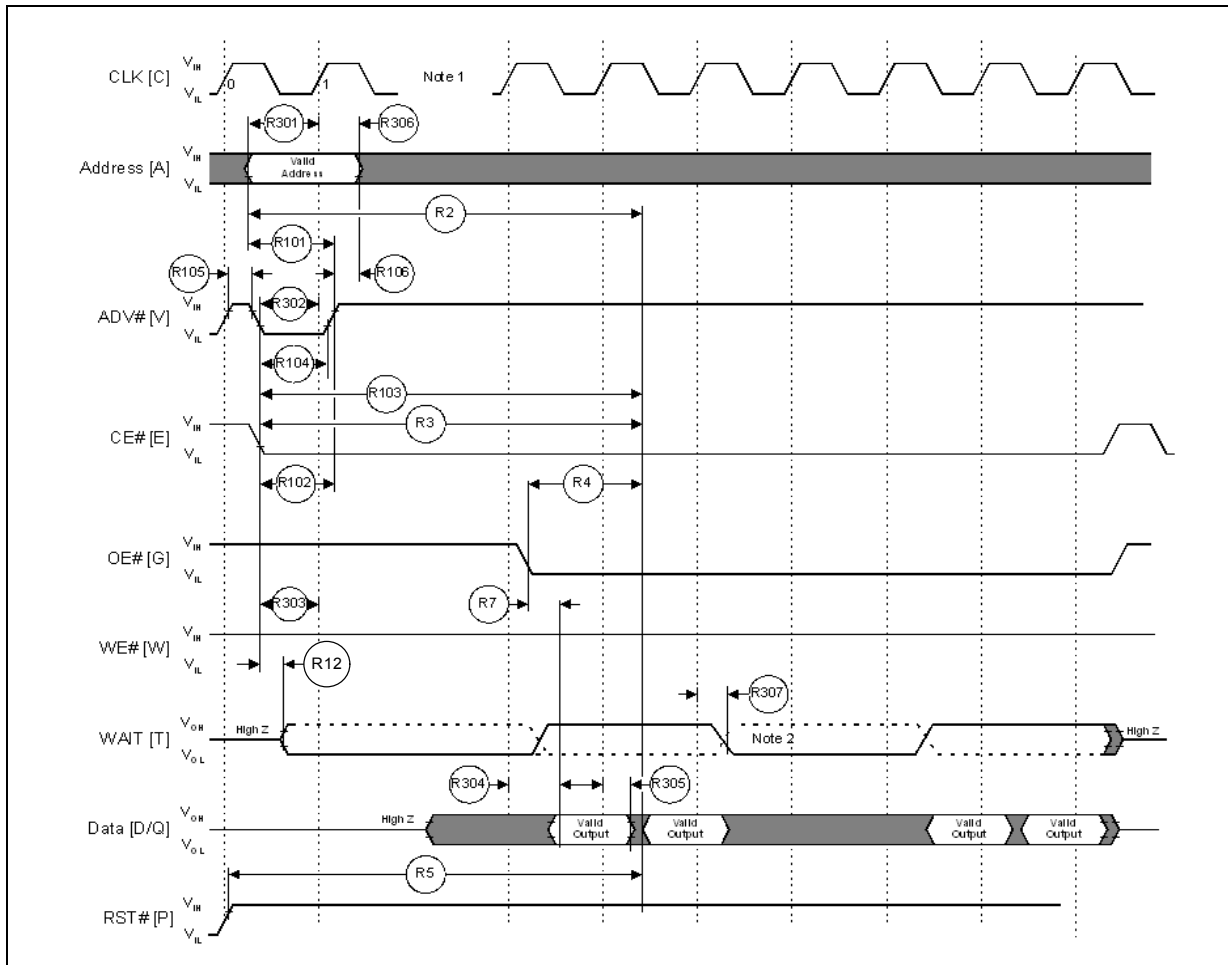

Notes:

1. Section 14.2, "First Access Latency Count (RCR[13:11])" on page 79 describes how to insert clock cycles during the initial access.
2. WAIT (shown asserted; RCR[10]=0) can be configured to assert either during, or one data cycle before, valid data (assumed wait delay of two clocks, for example).

Figure 12: WAIT Signal in Synchronous Non-Read Array Operation Waveform

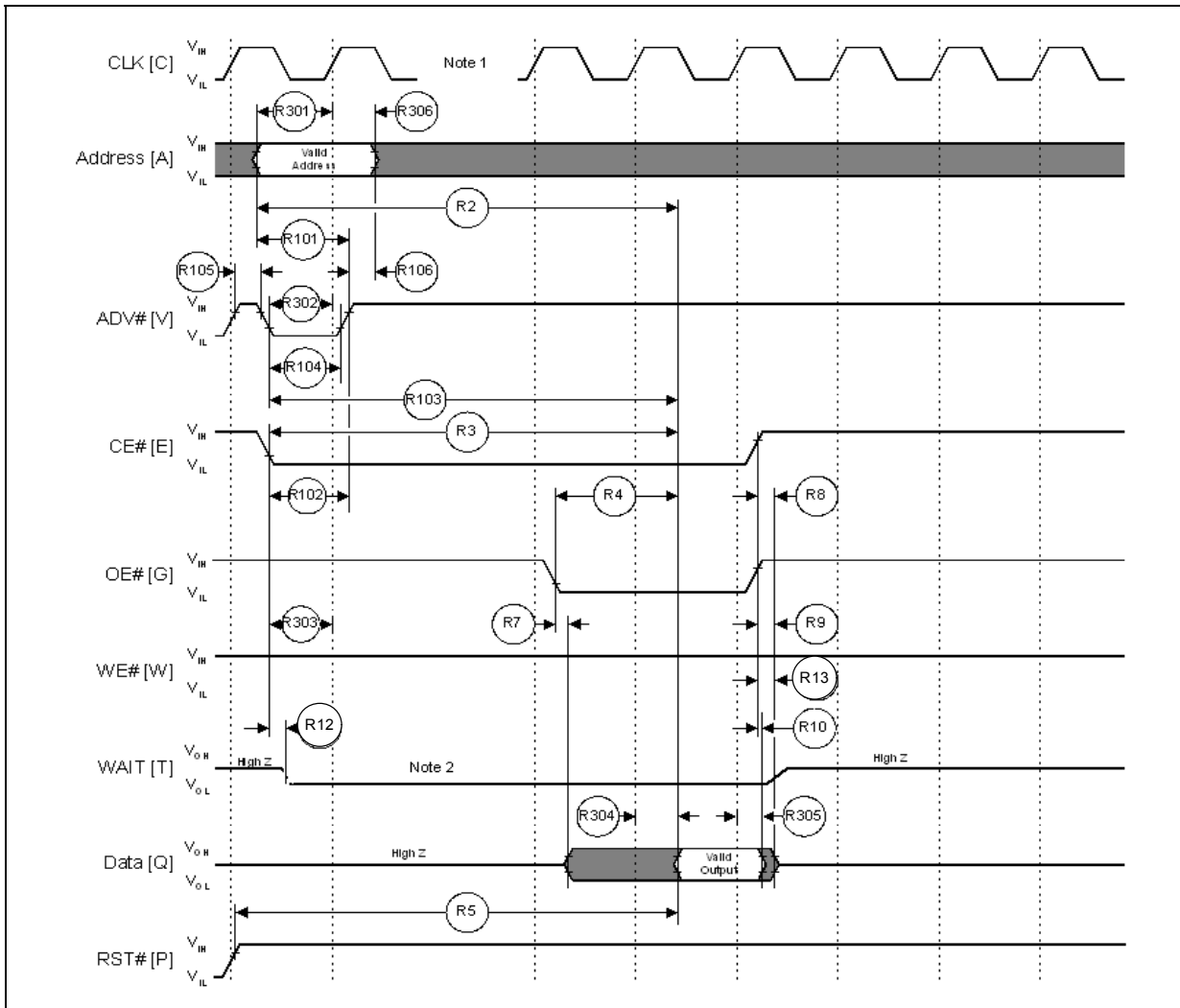

Notes:

1. Section 14.2, "First Access Latency Count (RCR[13:11])" on page 79 describes how to insert clock cycles during the initial access.
2. WAIT shown asserted (RCR[10]=0).

Figure 13: Burst Suspend

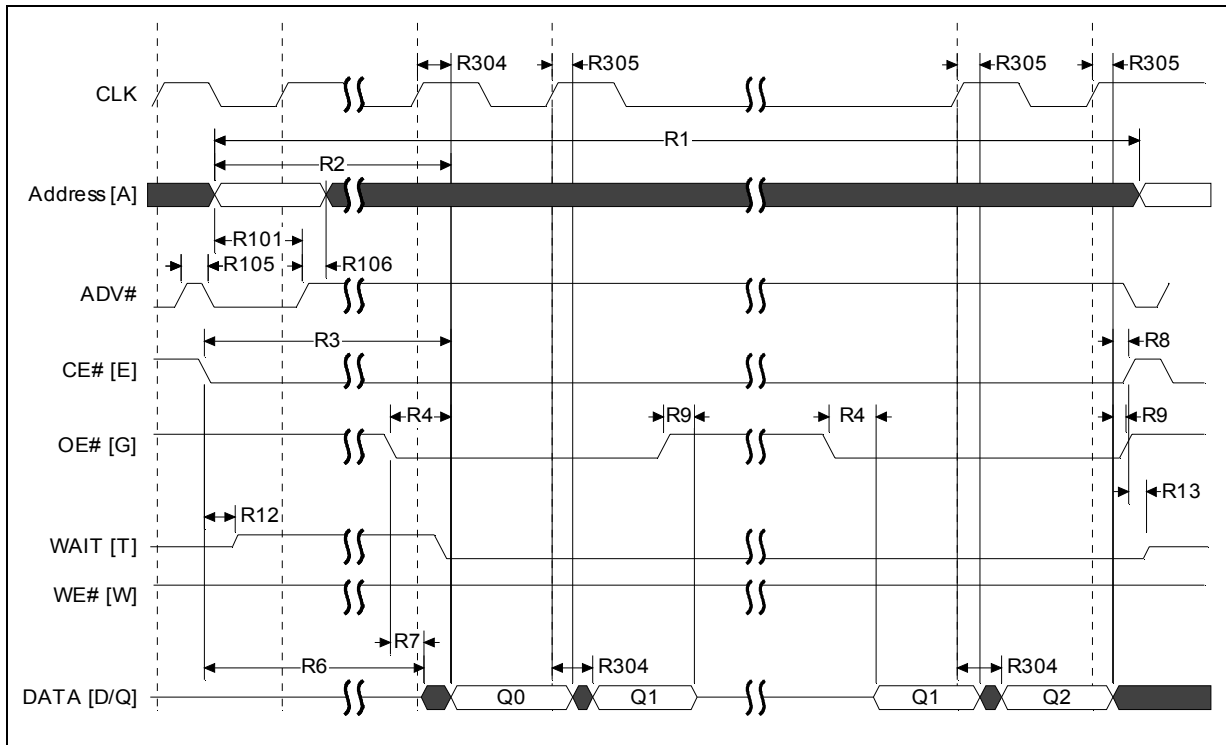

Note: During Burst Suspend, Clock signal can be held high or low.

7.1 AC Write Characteristics

Table 15: AC Write Characteristics – 90 nm (Sheet 1 of 2)

#	Sym	Parameter (1,2)	V _{CCQ} = 1.7 V – 1.95 V		Unit	Notes
			Min	Max		
W1	t _{PHWL} (t _{PHL})	RST# High Recovery to WE# (CE#) Low	150	-	ns	3
W2	t _{ELWL} (t _{WLEL})	CE# (WE#) Setup to WE# (CE#) Low	0	-	ns	
W3	t _{WLWH} (t _{ELEH})	WE# (CE#) Write Pulse Width Low	40	-	ns	4
W4	t _{DVWH} (t _{DVEH})	Data Setup to WE# (CE#) High	40	-	ns	
W5	t _{AVWH} (t _{AVEH})	Address Setup to WE# (CE#) High	40	-	ns	
W6	t _{WHEH} (t _{EHWH})	CE# (WE#) Hold from WE# (CE#) High	0	-	ns	
W7	t _{WHDX} (t _{EHDX})	Data Hold from WE# (CE#) High	0	-	ns	
W8	t _{WHAX} (t _{EHAX})	Address Hold from WE# (CE#) High	0	-	ns	
W9	t _{WHWL} (t _{EHEL})	WE# (CE#) Pulse Width High	20	-	ns	5,6,7
W10	t _{VPWH} (t _{VPEH})	VPP Setup to WE# (CE#) High	200	-	ns	3
W11	t _{QVVL}	VPP Hold from Valid SRD	0	-	ns	3,8
W12	t _{QVBL}	WP# Hold from Valid SRD	0	-	ns	3,8

Table 15: AC Write Characteristics – 90 nm (Sheet 2 of 2)

#	Sym	Parameter (1,2)	V _{CCQ} = 1.7 V – 1.95 V		Unit	Notes
			Min	Max		
W13	t _{BHWH} (t _{BHEH})	WP# Setup to WE# (CE#) High	200	-	ns	3
W14	t _{WHGL} (t _{EHGL})	Write Recovery before Read	0	-	ns	
W16	t _{WHQV}	WE# High to Valid Data	t _{AVQV} + 20	-	ns	3,6,10
W18	t _{WHAV}	WE# High to Address Valid	0	-	ns	3,9,10
W19	t _{WHCV}	WE# High to CLK Valid	12	-	ns	3,10
W20	t _{WHVH}	WE# High to ADV# High	12	-	ns	3,10
W21	t _{VHWL}	ADV# High to WE# Low		≤21	ns	11
W22	t _{CHWL}	CLK to WE# Low		≤21	ns	11
W27	t _{WHEL}	WE# High to CE# Low	0			
W28	t _{WHVL}	WE# High to ADV# Low	0			

Notes:

- Write timing characteristics during erase suspend are the same as during write-only operations.
- A write operation can be terminated with either CE# or WE#.
- Sampled, not 100% tested.
- Write pulse width low (t_{WLWH} or t_{ELEH}) is defined from CE# or WE# low (whichever occurs last) to CE# or WE# high (whichever occurs first). Hence, t_{WLWH} = t_{ELEH} = t_{WLEH} = t_{ELWH}.
- Write pulse width high (t_{WHWL} or t_{EHEL}) is defined from CE# or WE# high (whichever is first) to CE# or WE# low (whichever is last). Hence, t_{WLWH} = t_{EHEL} = t_{WHEL} = t_{EHWL}.
- System designers should take this into account and may insert a software No-Op instruction to delay the first read after issuing a command.
- For commands other than resume commands.
- V_{PP} should be held at V_{PP1} or V_{PP2} until block erase or program success is determined.
- Applicable during asynchronous reads following a write.
- t_{WHCH/L} OR t_{WHVH} must be met when transitioning from a write cycle to a synchronous burst read. t_{WHCH/L} and t_{WHVH} both refer to the address latching event (either the rising/falling clock edge or the rising ADV# edge, whichever occurs first).
- The specifications t_{VHWL} and t_{CHWL} can be ignored if there is no clock toggling during the write bus cycle.

Table 16: AC Write Characteristics – 130 nm (Sheet 1 of 2)

#	Sym	Parameter (1,2)	V _{CCQ} = 1.7 V – 2.24 V		Unit	Notes
			-60			
			Min	Max		
W1	t _{PHWL} (t _{PEHL})	RST# High Recovery to WE# (CE#) Low	150	-	ns	3
W2	t _{ELWL} (t _{WLEL})	CE# (WE#) Setup to WE# (CE#) Low	0	-	ns	
W3	t _{WLWH} (t _{ELEH})	WE# (CE#) Write Pulse Width Low	40	-	ns	4
W4	t _{DVWH} (t _{DVEH})	Data Setup to WE# (CE#) High	40	-	ns	
W5	t _{AVWH} (t _{AVEH})	Address Setup to WE# (CE#) High	40	-	ns	
W6	t _{WHEH} (t _{EHWH})	CE# (WE#) Hold from WE# (CE#) High	0	-	ns	
W7	t _{WHDX} (t _{EHDX})	Data Hold from WE# (CE#) High	0	-	ns	
W8	t _{WHAX} (t _{EHAX})	Address Hold from WE# (CE#) High	0	-	ns	
W9	t _{WHWL} (t _{EHEL})	WE# (CE#) Pulse Width High	20	-	ns	5,6,7
W10	t _{VPWH} (t _{VPEH})	VPP Setup to WE# (CE#) High	200	-	ns	3
W11	t _{QVVL}	VPP Hold from Valid SRD	0	-	ns	3,8
W12	t _{QVBL}	WP# Hold from Valid SRD	0	-	ns	3,8

Table 16: AC Write Characteristics — 130 nm (Sheet 2 of 2)

#	Sym	Parameter (1,2)	V _{CCQ} = 1.7 V – 2.24 V		Unit	Notes
			-60			
			Min	Max		
W13	t _{BHWH} (t _{BHEH})	WP# Setup to WE# (CE#) High	200	-	ns	3
W14	t _{WHGL} (t _{EHGL})	Write Recovery before Read	0	-	ns	
W16	t _{WHQV}	WE# High to Valid Data	t _{AVQV} +20	-	ns	3,6,10
W18	t _{WHAV}	WE# High to Address Valid	0	-	ns	3,9,10
W19	t _{WHCV}	WE# High to CLK Valid	12	-	ns	3,10
W20	t _{WHVH}	WE# High to ADV# High	12	-	ns	3,10

Notes: For all numbered note references in this table, refer to the notes in [Table 15, "AC Write Characteristics — 90 nm" on page 36.](#)

Figure 14: Write Operations Waveform

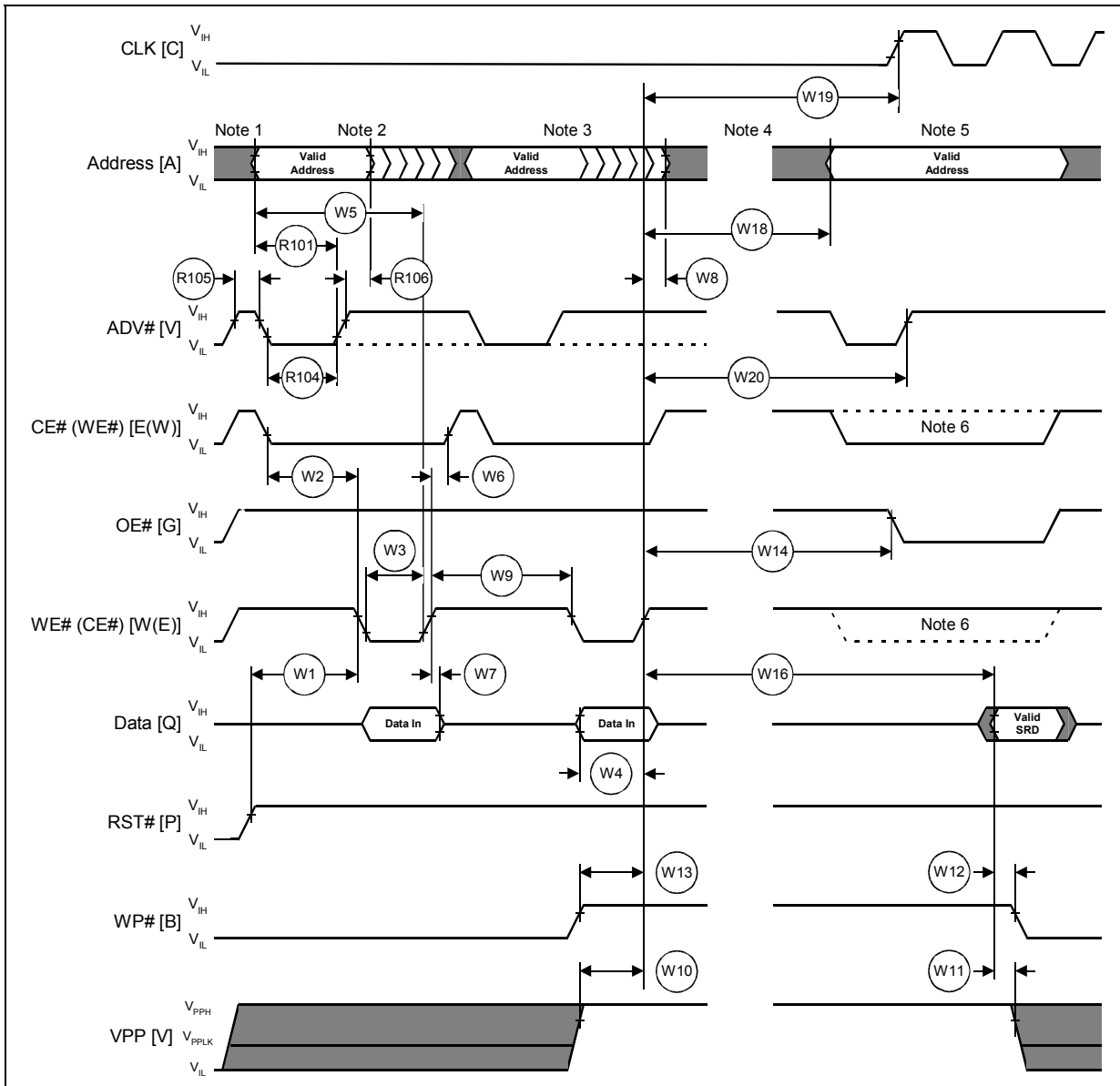

Notes:

1. V_{CC} power-up and standby.
2. Write Program or Erase Setup command.
3. Write valid address and data (for program) or Erase Confirm command.
4. Automated program/erase delay.
5. Read Status Register data (SRD) to determine program/erase operation completion.
6. OE# and CE# must be asserted and WE# must be deasserted for read operations.
7. CLK is ignored. (but may be kept active/toggling)

Figure 15: Asynchronous Read to Write Operation Waveform

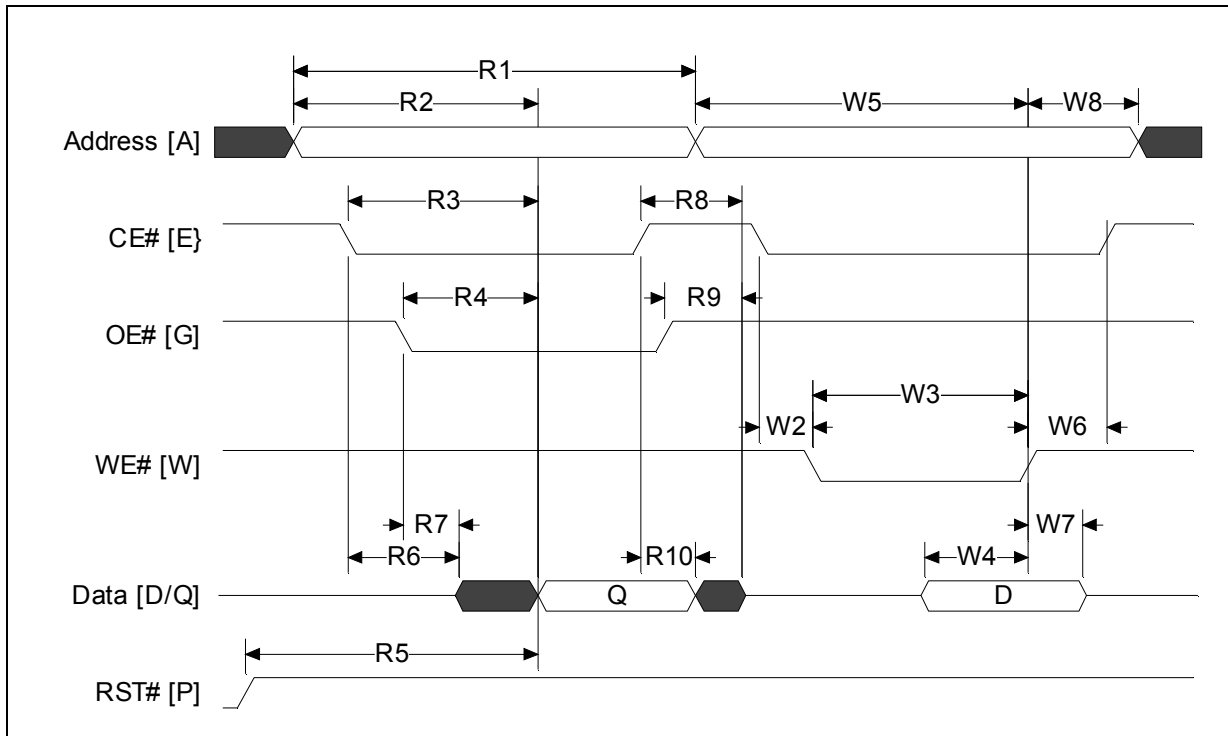

Figure 16: Asynchronous Write to Read Operation

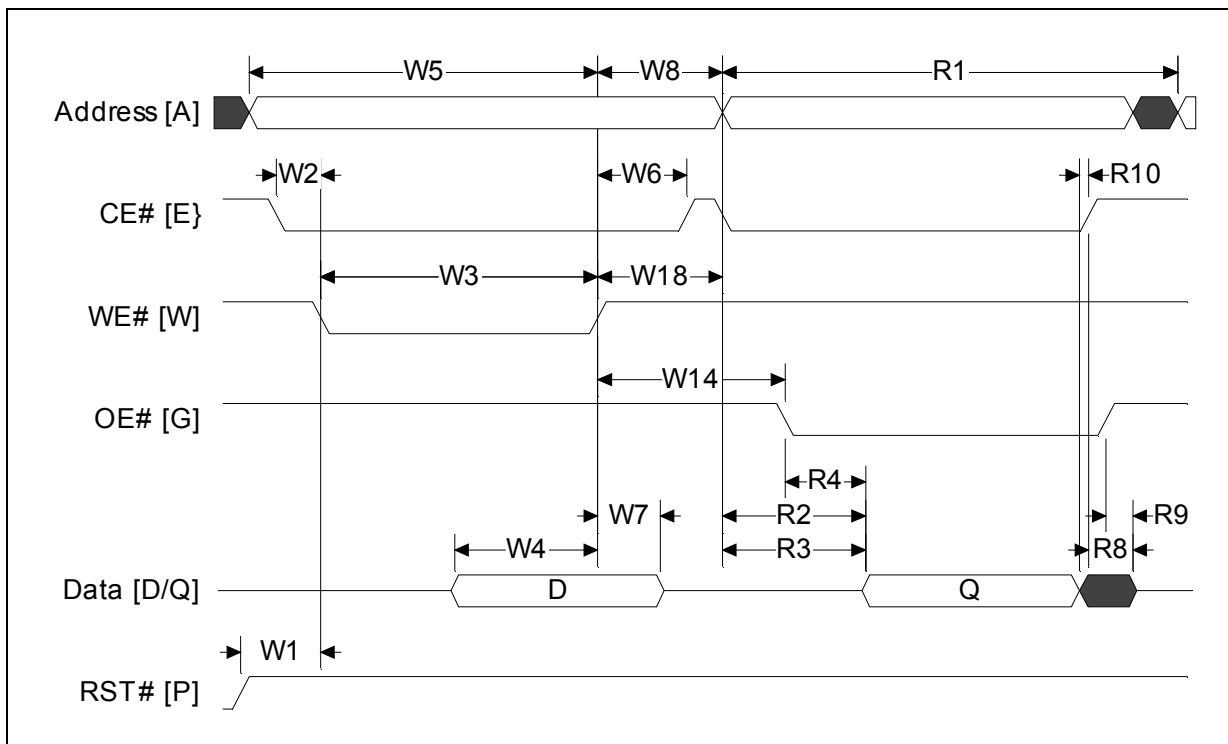

Figure 17: Synchronous Read to Write Operation

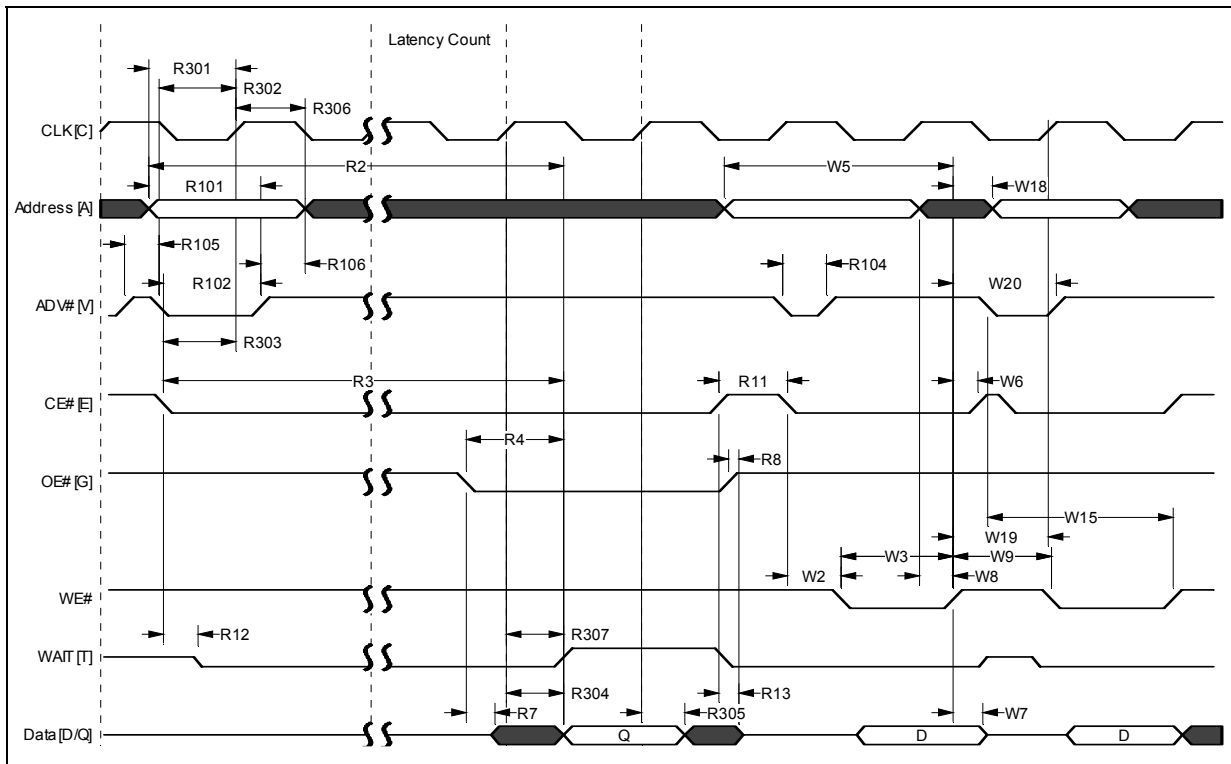
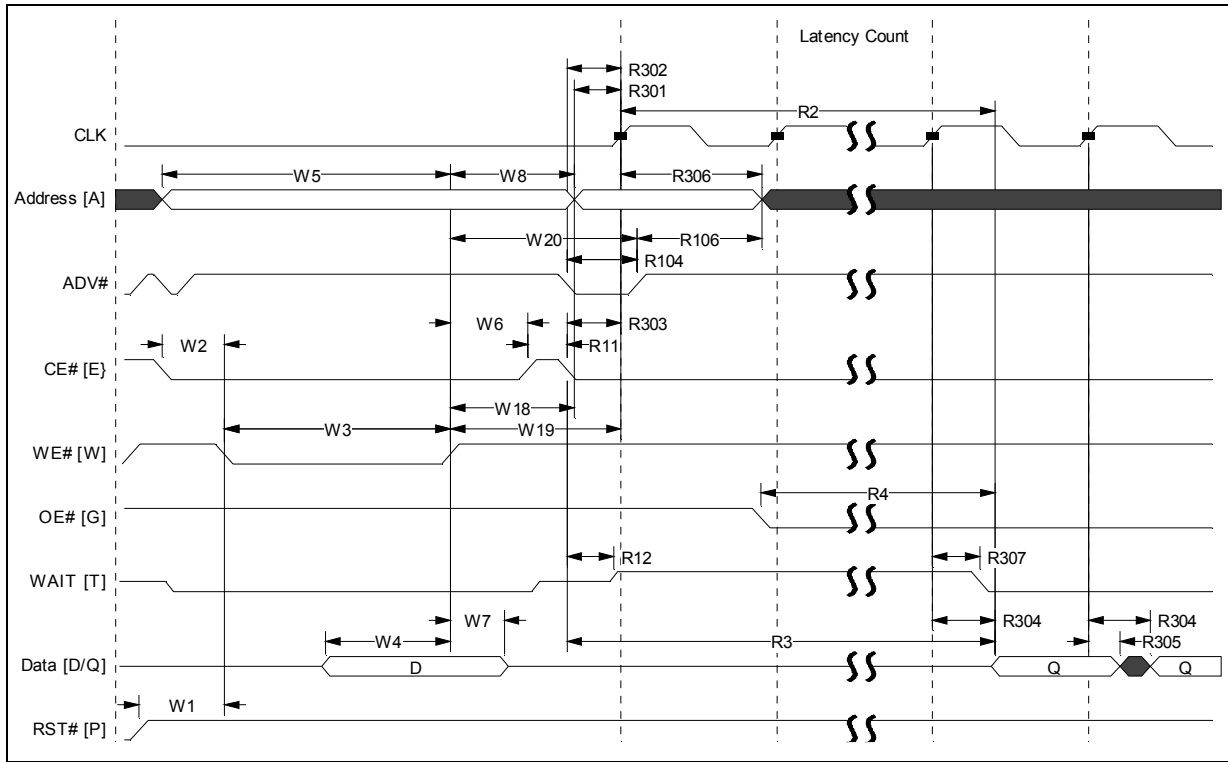

Figure 18: Synchronous Write To Read Operation



7.2 Erase and Program Times

Note: Specifications are for 130 nm and 90 nm devices unless otherwise stated.

Table 17: Erase and Program Times (Sheet 1 of 2)

Operation	Symbol	Parameter	Description ⁽¹⁾	Notes	V _{PP1}		V _{PP2}		Unit
					Typ	Max	Typ	Max	
Erasing and Suspending									
Erase Time	W500	t _{ERS/PB}	4-Kword Parameter Block	2,3	0.3	2.5	0.25	2.5	s
	W501	t _{ERS/MB}	32-Kword Main Block	2,3	0.7	4	0.4	4	s
Suspend Latency	W600	t _{SUSP/P}	Program Suspend	2	5	10	5	10	μs
	W601	t _{SUSP/E}	Erase Suspend	2	5	20	5	20	μs
Programming									
Program Time	W200	t _{PROG/W}	Single Word	2	12	150	8	130	μs
	W201	t _{PROG/PB}	4-Kword Parameter Block	2,3	0.05	.23	0.03	0.07	s
	W202	t _{PROG/MB}	32-Kword Main Block	2,3	0.4	1.8	0.24	0.6	s
Enhanced Factory Programming ⁽⁵⁾									

Table 17: Erase and Program Times (Sheet 2 of 2)

Operation	Symbol	Parameter	Description ⁽¹⁾	Notes	V _{PP1}		V _{PP2}		Unit
					Typ	Max	Typ	Max	
Program	W400	tEFP/W	Single Word	4	N/A	N/A	3.1	16	μs
	W401	tEFP/PB	4-Kword Parameter Block	2,3	N/A	-	15	-	ms
	W402	tEFP/MB	32-Kword Main Block	2,3	N/A	-	120	-	ms
Operation Latency	W403	t _{EFP/SETUP}	EFP Setup		-	N/A	-	5	μs
	W404	t _{EFP/TRAN}	Program to Verify Transition		N/A	N/A	2.7	5.6	μs
	W405	t _{EFP/VERIFY}	Verify		N/A	N/A	1.7	130	μs

Notes:

1. Unless noted otherwise, all parameters are measured at T_A = +25 °C and nominal voltages, and they are sampled, not 100% tested.
2. Excludes external system-level overhead.
3. Exact results may vary based on system overhead.
4. W400-Typ is the calculated delay for a single programming pulse. W400-Max includes the delay when programming within a new word-line.
5. Some EFP performance degradation may occur if block cycling exceeds 10.

7.3 Reset Specifications

Note: Specifications are for 130 nm and 90 nm devices unless otherwise stated.

Table 18: Reset Specifications

#	Symbol	Parameter ⁽¹⁾	Notes	Min	Max	Unit
P1	t _{PLPH}	RST# Low to Reset during Read	1, 2, 3, 4	100	-	ns
P2	t _{PLRH}	RST# Low to Reset during Block Erase	1, 3, 4, 5	-	20	μs
		RST# Low to Reset during Program	1, 3, 4, 5	-	10	μs
P3	t _{VCCPH}	VCC Power Valid to Reset	1,3,4,5,6	60	-	μs

Notes:

1. These specifications are valid for all product versions (packages and speeds).
2. The device may reset if t_{PLPH} < t_{PLPH}Min, but this is not guaranteed.
3. Not applicable if RST# is tied to VCC.
4. Sampled, but not 100% tested.
5. If RST# is tied to VCC, the device is not ready until t_{VCCPH} occurs after when V_{CC} ≥ V_{CC}Min.
6. If RST# is tied to any supply/signal with V_{CCQ} voltage levels, the RST# input voltage must not exceed V_{CC} until V_{CC} ≥ V_{CC}Min.

Figure 19: Reset Operations Waveforms

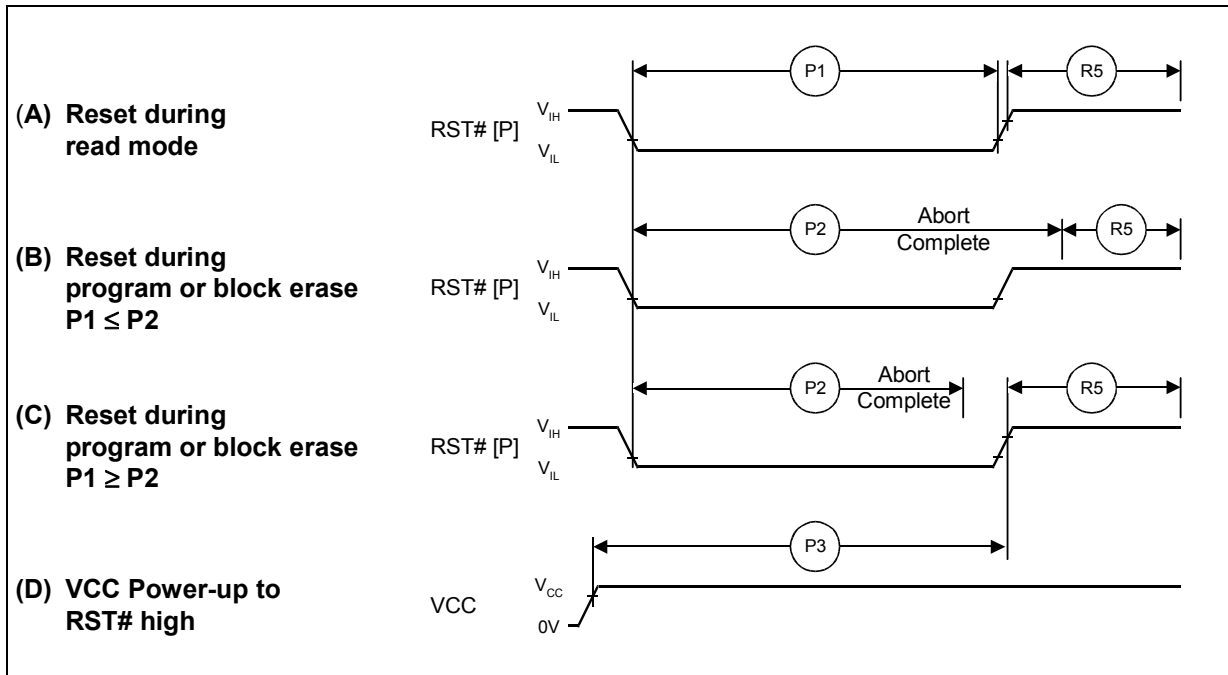

7.4 AC I/O Test Conditions

Figure 20: AC Input/Output Reference Waveform

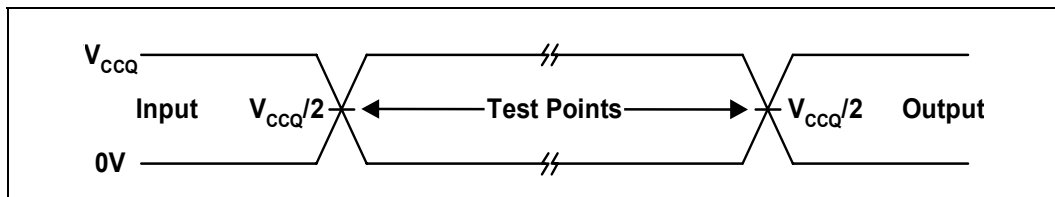

Note: Input timing begins, and output timing ends, at $V_{CCQ}/2$. Input rise and fall times (10% to 90%) < 5 ns. Worst case speed conditions are when $V_{CC} = V_{CCMin}$.

Figure 21: Transient Equivalent Testing Load Circuit

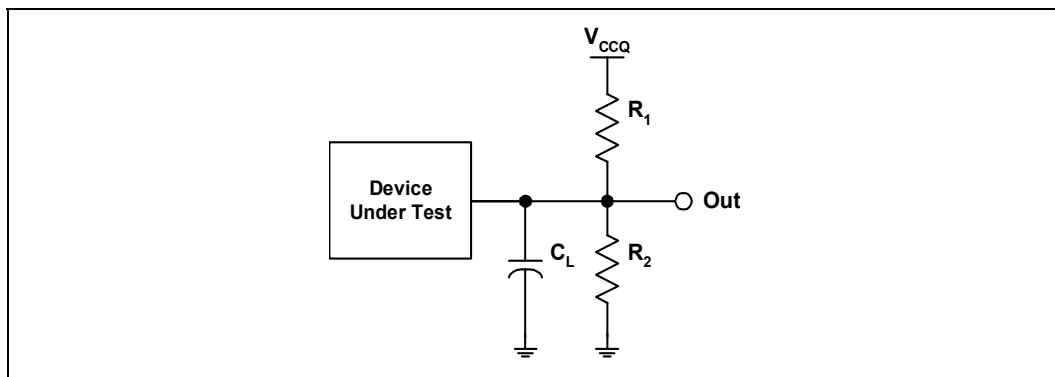

Note: See [Table 18 on page 43](#) for component values.

Table 19: Test Configuration Component Values for Worst Case Speed Conditions

Test Configuration	C _L (pF)	R ₁ (kΩ)	R ₂ (kΩ)
V _{CCQ} Min (1.7 V) Standard Test	30	16.7	16.7

Note: C_L includes jig capacitance.

Figure 22: Clock Input AC Waveform

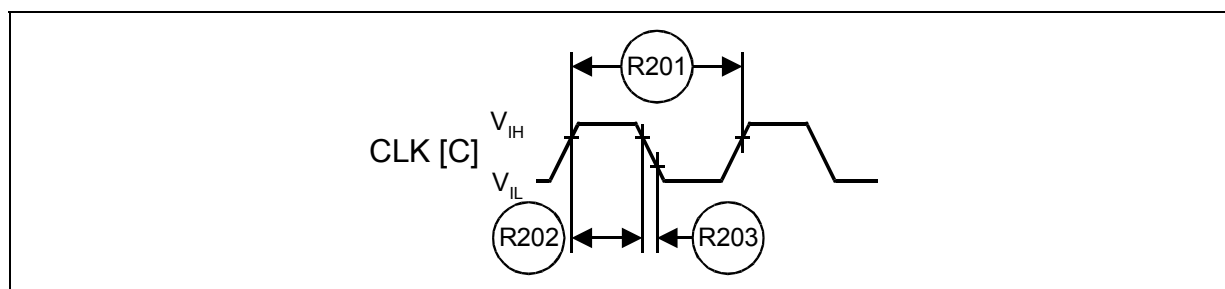

7.5 Device Capacitance

T_A = +25 °C, f = 1 MHz

Table 20: Capacitance

Symbol	Parameter§	Typ	Max	Unit	Condition
C _{IN}	Input Capacitance	6	8	pF	V _{IN} = 0.0 V
C _{OUT}	Output Capacitance	8	12	pF	V _{OUT} = 0.0 V
C _{CE}	CE# Input Capacitance	10	12	pF	V _{IN} = 0.0 V

§Sampled, not 100% tested.

8.0 Power and Reset Specifications

Numonyx™ Wireless Flash Memory (W18) devices have a layered approach to power savings that can significantly reduce overall system power consumption. The APS feature reduces power consumption when the device is selected but idle. If CE# is deasserted, the memory enters its standby mode, where current consumption is even lower. Asserting RST# provides current savings similar to standby mode. The combination of these features can minimize memory power consumption, and therefore, overall system power consumption.

8.1 Active Power

With CE# at V_{IL} and RST# at V_{IH} , the device is in the active mode. Refer to [Section 6.1, "DC Current Characteristics" on page 23](#), for I_{CC} values. When the device is in "active" state, it consumes the most power from the system. Minimizing device active current therefore reduces system power consumption, especially in battery-powered applications.

8.2 Automatic Power Savings (APS)

Automatic Power Saving (APS) provides low-power operation during a read's active state. During APS mode, I_{CCAPS} is the average current measured over any 5 ms time interval 5 μ s after the following events happen:

- There is no internal sense activity;
- CE# is asserted;
- The address lines are quiescent, and at V_{SSQ} or V_{CCQ} .

OE# may be asserted during APS.

8.3 Standby Power

With CE# at V_{IH} and the device in read mode, the flash memory is in standby mode, which disables most device circuitry and substantially reduces power consumption. Outputs are placed in a high-impedance state independent of the OE# signal state. If CE# transitions to V_{IH} during erase or program operations, the device continues the operation and consumes corresponding active power until the operation is complete. I_{CCS} is the average current measured over any 5 ms time interval 5 μ s after a CE# deassertion.

8.4 Power-Up/Down Characteristics

The device is protected against accidental block erasure or programming during power transitions. Power supply sequencing is not required if V_{CC} , V_{CCQ} , and V_{PP} are connected together; so it doesn't matter whether V_{PP} or V_{CC} powers-up first. If V_{CCQ} and/or V_{PP} are not connected to the system supply, then V_{CC} should attain V_{CCMIN} before applying V_{CCQ} and V_{PP} . Device inputs should not be driven before supply voltage = V_{CCMIN} . Power supply transitions should only occur when RST# is low.

8.4.1 System Reset and RST#

The use of RST# during system reset is important with automated program/erase devices because the system expects to read from the flash memory when it comes out of reset. If a CPU reset occurs without a flash memory reset, proper CPU initialization

will not occur because the flash memory may be providing status information instead of array data. To allow proper CPU/flash initialization at system reset, connect RST# to the system CPU RESET# signal.

System designers must guard against spurious writes when VCC voltages are above V_{LKO} . Because both WE# and CE# must be low for a command write, driving either signal to V_{IH} inhibits writes to the device. The CUI architecture provides additional protection because alteration of memory contents can only occur after successful completion of the two-step command sequences. The device is also disabled until RST# is brought to V_{IH} , regardless of its control input states. By holding the device in reset (RST# connected to system PowerGood) during power-up/down, invalid bus conditions during power-up can be masked, providing yet another level of memory protection.

8.4.2 VCC, VPP, and RST# Transitions

The CUI latches commands issued by system software and is not altered by VPP or CE# transitions or WSM actions. Read-array mode is its power-up default state after exit from reset mode or after VCC transitions above V_{LKO} (Lockout voltage). After completing program or block erase operations (even after VPP transitions below V_{PPLK}), the Read Array command must reset the CUI to read-array mode if flash memory array access is desired.

8.5 Power Supply Decoupling

When the device is accessed, many internal conditions change. Circuits are enabled to charge pumps and switch voltages. This internal activity produces transient noise. To minimize the effect of this transient noise, device decoupling capacitors are required. Transient current magnitudes depend on the device outputs' capacitive and inductive loading. Two-line control and proper decoupling capacitor selection suppresses these transient voltage peaks. Each flash device should have a 0.1 μF ceramic capacitor connected between each power (VCC, VCCQ, VPP) and ground (VSS, VSSQ) signal. High-frequency, inherently low-inductance capacitors should be as close as possible to package signals.

9.0 Bus Operations Overview

This section provides an overview of device bus operations. The Numonyx™ Wireless Flash Memory (W18) family includes an on-chip WSM to manage block erase and program algorithms. Its Command User Interface (CUI) allows minimal processor overhead with RAM-like interface timings. Device commands are written to the CUI using standard microprocessor timings.

9.1 Bus Operations

Bus cycles to/from the W18 device conform to standard microprocessor bus operations. [Table 21](#) summarizes the bus operations and the logic levels that must be applied to the device's control signal inputs.

Table 21: Bus Operations Summary

Bus Operation		RST#	CLK	ADV#	CE#	OE#	WE#	WAIT	DQ[15:0] ↓	Notes
Read	Asynchronous	V _{IH}	X	L	L	L	H	Asserted	Output	
	Synchronous	V _{IH}	Running	L	L	L	H	Driven	Output	1
	Burst Suspend	V _{IH}	Halted	X	L	H	H	Active	Output	
Write		V _{IH}	X	L	L	H	L	Asserted	Input	2
Output Disable		V _{IH}	X	X	L	H	H	Asserted	High-Z	3
Standby		V _{IH}	X	X	H	X	X	High-Z	High-Z	3
Reset		V _{IL}	X	X	X	X	X	High-Z	High-Z	3,4

Notes:

1. WAIT is only valid during synchronous array-read operations.
2. Refer to the [Table 23, "Bus Cycle Definitions" on page 52](#) for valid DQ[15:0] during a write operation.
3. X = Don't Care (H or L).
4. RST# must be at V_{SS} ± 0.2 V to meet the maximum specified power-down current.

9.1.1 Reads

Device read operations are performed by placing the desired address on A[22:0] and asserting CE# and OE#. ADV# must be low, and WE# and RST# must be high. All read operations are independent of the voltage level on V_{PP}.

CE#-low selects the device and enables its internal circuits. OE#-low or WE#-low determine whether DQ[15:0] are outputs or inputs, respectively. OE# and WE# must not be low at the same time - indeterminate device operation will result.

In asynchronous-page mode, the rising edge of ADV# can be used to latch the address. If only asynchronous read mode is used, ADV# can be tied to ground. CLK is not used in asynchronous-page mode and should be tied high.

In synchronous-burst mode, ADV# is used to latch the initial address - either on the rising edge of ADV# or the rising (or falling) edge of CLK with ADV# low, whichever occurs first. CLK is used in synchronous-burst mode to increment the internal address counter, and to output read data on DQ[15:0].

Each device partition can be placed in any of several read states:

- **Read Array:** Returns flash array data from the addressed location.
- **Read Identifier (ID):** Returns manufacturer ID and device ID codes, block lock status, and protection register data. Read Identifier information can be accessed from any 4-Mbit partition base address.

- **CFI Query:** Returns Common Flash Interface (CFI) information. CFI information can be accessed starting at 4-Mbit partition base addresses.
- **Read Status Register:** Returns Status Register (SR) data from the addressed partition.

The appropriate CUI command must be written to the partition in order to place it in the desired read state (see [Table 22, “Command Codes and Descriptions” on page 51](#)). Non-array read operations (Read ID, CFI Query, and Read Status Register) execute as single synchronous or asynchronous read cycles. WAIT is asserted throughout non-array read operations.

9.1.2 Writes

Device write operations are performed by placing the desired address on A[22:0] and asserting CE# and WE#. OE# and RST# must be high. Data to be written at the desired address is placed on DQ[15:0]. ADV# must be held low throughout the write cycle or it can be toggled to latch the address. If ADV# is held low, the address and data are latched on the rising edge of WE#. CLK is not used during write operations, and is ignored; it can be either free-running or halted at V_{IL} or V_{IH} . All write operations are asynchronous.

[Table 22, “Command Codes and Descriptions” on page 51](#) shows the available device commands. [Appendix A, “Write State Machine States” on page 86](#) provides information on moving between different device operations by using CUI commands.

9.1.3 Output Disable

When OE# is deasserted, device outputs DQ[15:0] are disabled and placed in a high-impedance (High-Z) state.

9.1.4 Burst Suspend

The Burst Suspend feature allows the system to temporarily suspend a synchronous-burst read operation. This can be useful if the system needs to access another device on the same address and data bus as the flash during a burst-read operation.

Synchronous-burst accesses can be suspended during the initial latency (before data is received) or after the device has output data. When a burst access is suspended, internal array sensing continues and any previously latched internal data is retained.

Burst Suspend occurs when CE# is asserted, the current address has been latched (either ADV# rising edge or valid CLK edge), CLK is halted, and OE# is deasserted. CLK can be halted when it is at V_{IH} or V_{IL} . To resume the burst access, OE# is reasserted and CLK is restarted. Subsequent CLK edges resume the burst sequence where it left off.

Within the device, CE# gates WAIT. Therefore, during Burst Suspend WAIT is still driven. This can cause contention with another device attempting to control the system's READY signal during a Burst Suspend. Systems using the Burst Suspend feature should not connect the device's WAIT signal directly to the system's READY signal. Refer to [Figure 13, “Burst Suspend” on page 36](#).

9.1.5 Standby

De-asserting CE# deselects the device and places it in standby mode, substantially reducing device power consumption. In standby mode, outputs are placed in a high-impedance state independent of OE#. If deselected during a program or erase algorithm, the device shall consume active power until the program or erase operation completes.

9.1.6 Reset

The device enters a reset mode when RST# is asserted. In reset mode, internal circuitry is turned off and outputs are placed in a high-impedance state.

After returning from reset, a time t_{PHQV} is required until outputs are valid, and a delay (t_{PHWV}) is required before a write sequence can be initiated. After this wake-up interval, normal operation is restored. The device defaults to read-array mode, the Status Register is set to 80h, and the Configuration Register defaults to asynchronous page-mode reads.

If RST# is asserted during an erase or program operation, the operation aborts and the memory contents at the aborted block or address are invalid. See [Figure 19, "Reset Operations Waveforms" on page 44](#) for detailed information regarding reset timings.

Like any automated device, it is important to assert RST# during system reset. When the system comes out of reset, the processor expects to read from the flash memory array. Automated flash memories provide status information when read during program or erase operations. If a CPU reset occurs with no flash memory reset, proper CPU initialization may not occur because the flash memory may be providing status information instead of array data. Numonyx flash memories allow proper CPU initialization following a system reset through the use of the RST# input. In this application, RST# is controlled by the same CPU reset signal.

9.2 Device Commands

The device's on-chip WSM manages erase and program algorithms. This local CPU (WSM) controls the device's in-system read, program, and erase operations. Bus cycles to or from the flash memory conform to standard microprocessor bus cycles. RST#, CE#, OE#, WE#, and ADV# control signals dictate data flow into and out of the device. WAIT informs the CPU of valid data during burst reads. [Table 21, "Bus Operations Summary" on page 48](#) summarizes bus operations.

Device operations are selected by writing specific commands into the device's CUI. [Table 22, "Command Codes and Descriptions" on page 51](#) lists all possible command codes and descriptions. [Table 23, "Bus Cycle Definitions" on page 52](#) lists command definitions. Because commands are partition-specific, it is important to issue write commands within the target address range.

Table 22: Command Codes and Descriptions (Sheet 1 of 2)

Operation	Code	Device Command	Description
Read	FFh	Read Array	Places selected partition in Read Array mode.
	70h	Read Status Register	Places selected partition in Status Register read mode. After issuing this command, reading from the partition outputs SR data on DQ[15:0]. A partition automatically enters this mode after issuing the Program or Erase command.
	90h	Read Identifier	Places the selected partition in Read ID mode. Device reads from partition addresses output manufacturer/device codes, Configuration Register data, block lock status, or protection register data on DQ[15:0].
	98h	CFI Query	Puts the addressed partition in CFI Query mode. Device reads from the partition addresses output CFI information on DQ[7:0].
	50h	Clear Status Register	The WSM can set the Status Register's block lock (SR[1]), V _{pp} (SR[3]), program (SR[4]), and erase (SR[5]) status bits, but it cannot clear them. SR[5:3,1] can only be cleared by a device reset or through the Clear Status Register command.
Program	40h	Word Program Setup	This preferred program command's first cycle prepares the CUI for a program operation. The second cycle latches address and data, and executes the WSM program algorithm at this location. Status register updates occur when CE# or OE# is toggled. A Read Array command is required to read array data after programming.
	10h	Alternate Setup	Equivalent to a Program Setup command (40h).
	30h	EFP Setup	This program command activates EFP mode. The first write cycle sets up the command. If the second cycle is an EFP Confirm command (D0h), subsequent writes provide program data. All other commands are ignored after EFP mode begins.
	D0h	EFP Confirm	If the first command was EFP Setup (30h), the CUI latches the address and data, and prepares the device for EFP mode.
Erase	20h	Erase Setup	This command prepares the CUI for Block Erase. The device erases the block addressed by the Erase Confirm command. If the next command is not Erase Confirm, the CUI sets Status Register bits SR[5:4] to indicate command sequence error and places the partition in the read Status Register mode.
	D0h	Erase Confirm	If the first command was Erase Setup (20h), the CUI latches address and data, and erases the block indicated by the erase confirm cycle address. During program or erase, the partition responds only to Read Status Register, Program Suspend, and Erase Suspend commands. CE# or OE# toggle updates Status Register data.
Suspend	B0h	Program Suspend or Erase Suspend	This command, issued at any device address, suspends the currently executing program or erase operation. Status register data indicates the operation was successfully suspended if SR[2] (program suspend) or SR[6] (erase suspend) and SR[7] are set. The WSM remains in the suspended state regardless of control signal states (except RST#).
	D0h	Suspend Resume	This command, issued at any device address, resumes the suspended program or erase operation.
Block Locking	60h	Lock Setup	This command prepares the CUI lock configuration. If the next command is not Lock Block, Unlock Block, or Lock-Down, the CUI sets SR[5:4] to indicate command sequence error.
	01h	Lock Block	If the previous command was Lock Setup (60h), the CUI locks the addressed block.
	D0h	Unlock Block	If the previous command was Lock Setup (60h), the CUI latches the address and unlocks the addressed block. If previously locked-down, the operation has no effect.
	2Fh	Lock-Down	If the previous command was Lock Setup (60h), the CUI latches the address and locks-down the addressed block.

Table 22: Command Codes and Descriptions (Sheet 2 of 2)

Operation	Code	Device Command	Description
Protection	C0h	Protection Program Setup	This command prepares the CUI for a protection register program operation. The second cycle latches address and data, and starts the WSM's protection register program or lock algorithm. Toggling CE# or OE# updates the flash Status Register data. To read array data after programming, issue a Read Array command.
Configuration	60h	Configuration Setup	This command prepares the CUI for device configuration. If Set Configuration Register is not the next command, the CUI sets SR[5:4] to indicate command sequence error.
	03h	Set Configuration Register	If the previous command was Configuration Setup (60h), the CUI latches the address and writes the data from A[15:0] into the configuration register. Subsequent read operations access array data.

Note: Do not use unassigned commands. Numonyx reserves the right to redefine these codes for future functions.

Table 23: Bus Cycle Definitions

Operation	Command	Bus Cycles	First Bus Cycle			Second Bus Cycle		
			Oper	Addr ¹	Data ^{2,3}	Oper	Addr ¹	Data ^{2,3}
Read	Read Array/Reset	≥1	Write	PnA	FFh	Read	Read Address	Array Data
	Read Identifier	≥ 2	Write	PnA	90h	Read	PBA+IA	IC
	CFI Query	≥ 2	Write	PnA	98h	Read	PBA+QA	QD
	Read Status Register	2	Write	PnA	70h	Read	PnA	SRD
	Clear Status Register	1	Write	XX	50h			
Program and Erase	Block Erase	2	Write	BA	20h	Write	BA	D0h
	Word Program	2	Write	WA	40h/10h	Write	WA	WD
	EFP	≥2	Write	WA	30h	Write	WA	D0h
	Program/Erase Suspend	1	Write	XX	B0h			
	Program/Erase Resume	1	Write	XX	D0h			
Lock	Lock Block	2	Write	BA	60h	Write	BA	01h
	Unlock Block	2	Write	BA	60h	Write	BA	D0h
	Lock-Down Block	2	Write	BA	60h	Write	BA	2Fh

Table 23: Bus Cycle Definitions

Operation	Command	Bus Cycles	First Bus Cycle			Second Bus Cycle		
			Oper	Addr ¹	Data ^{2,3}	Oper	Addr ¹	Data ^{2,3}
Protection	Protection Program	2	Write	PA	C0h	Write	PA	PD
	Lock Protection Program	2	Write	LPA	C0h	Write	LPA	FFFDh
Configuration	Set Configuration Register	2	Write	CD	60h	Write	CD	03h

Notes:

- First-cycle command addresses should be the same as the operation’s target address. Examples: the first-cycle address for the Read Identifier command should be the same as the Identification code address (IA); the first-cycle address for the Word Program command should be the same as the word address (WA) to be programmed; the first-cycle address for the Erase/Program Suspend command should be the same as the address within the block to be suspended; etc.
 XX = Any valid address within the device.
 IA = Identification code address.
 BA = Block Address. Any address within a specific block.
 LPA = Lock Protection Address is obtained from the CFI (through the CFI Query command). The Numonyx Wireless Flash Memory (W18) family’s LPA is at 0080h.
 PA = User programmable 4-word protection address.
 PnA = Any address within a specific partition.
 PBA = Partition Base Address. The very first address of a particular partition.
 QA = CFI code address.
 WA = Word address of memory location to be written.
- SRD = Status register data.
 WD = Data to be written at location WA.
 IC = Identifier code data.
 PD = User programmable 4-word protection data.
 QD = Query code data on DQ[7:0].
 CD = Configuration register code data presented on device addresses A[15:0]. A[MAX:16] address bits can select any partition. See [Table 31, “Read Configuration Register Descriptions” on page 78](#) for Configuration Register bits descriptions.
- Commands other than those shown above are reserved by Numonyx for future device implementations and should not be used.

9.3 Command Sequencing

When issuing a 2-cycle write sequence to the flash device, a read operation is allowed to occur *between* the two write cycles. The setup phase of a 2-cycle write sequence places the addressed partition into read-status mode, so if the same partition is read before the second “confirm” write cycle is issued, Status Register data will be returned. Reads from other partitions, however, can return actual array data assuming the addressed partition is already in read-array mode. [Figure 23](#) and [Figure 24](#) illustrate these two conditions.

Figure 23: Normal Write and Read Cycles

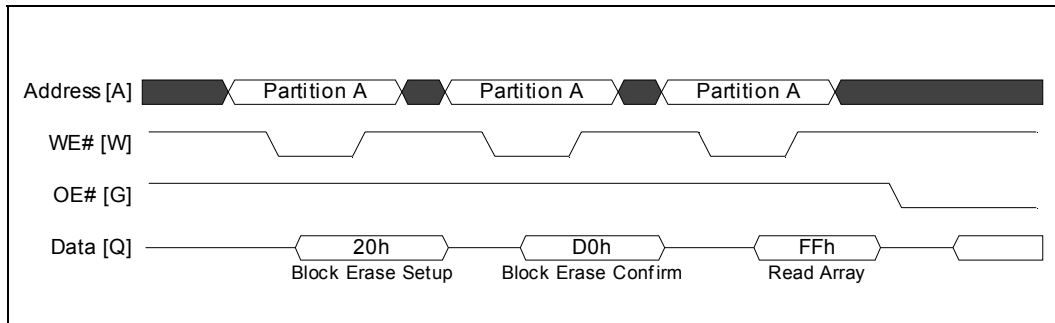
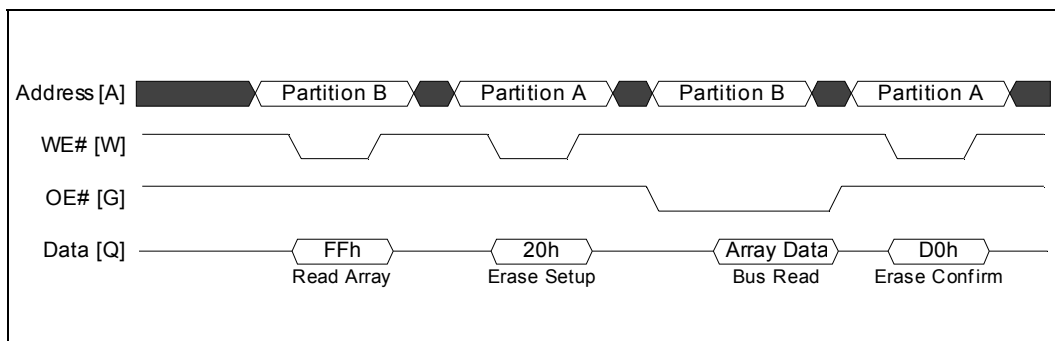
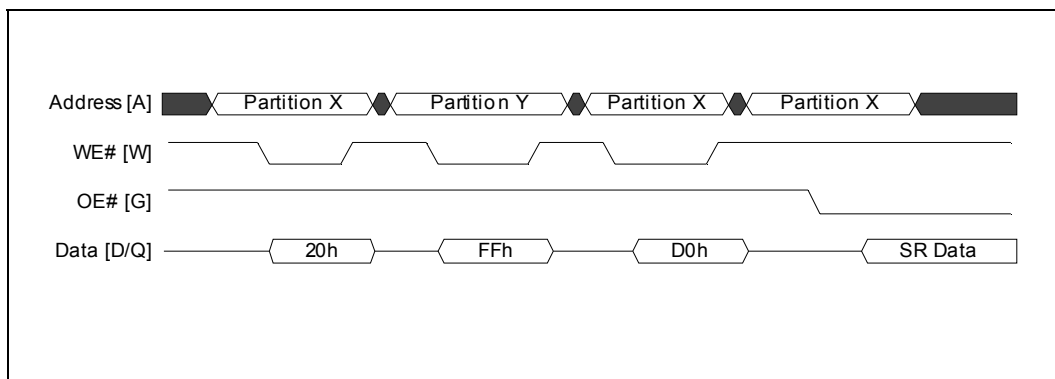

Figure 24: Interleaving a 2-Cycle Write Sequence with an Array Read



By contrast, a write bus cycle may not interrupt a 2-cycle write sequence. Doing so causes a command sequence error to appear in the Status Register. [Figure 25](#) illustrates a command sequence error.

Figure 25: Improper Command Sequencing



10.0 Read Operations

The device supports two read modes - asynchronous page and synchronous burst mode. Asynchronous page mode is the default read mode after device power-up or a reset. The Read Configuration Register (RCR) must be configured to enable synchronous burst reads of the flash memory array (see [Section 14.0, "Set Read Configuration Register" on page 78](#)).

Each partition of the device can be in any of four read states: Read Array, Read Identifier, Read Status or CFI Query. Upon power-up, or after a reset, all partitions of the device default to the Read Array state. To change a partition's read state, the appropriate read command must be written to the device (see [Section 9.2, "Device Commands" on page 50](#)).

The following sections describe device read modes and read states in detail.

10.1 Asynchronous Page Read Mode

Following a device power-up or reset, asynchronous page mode is the default read mode and all partitions are set to Read Array. However, to perform array reads after any other device operation (e.g. write operation), the Read Array command must be issued in order to read from the flash memory array.

Note: Asynchronous page-mode reads can only be performed when Read Configuration Register bit RCR[15] is set (see [Section 14.0, "Set Read Configuration Register" on page 78](#)).

To perform an asynchronous page mode read, an address is driven onto A[MAX:0], and CE#, OE# and ADV# are asserted. WE# and RST# must be deasserted. WAIT is asserted during asynchronous page mode. ADV# can be driven high to latch the address, or it must be held low throughout the read cycle. CLK is not used for asynchronous page-mode reads, and is ignored. If only asynchronous reads are to be performed, CLK should be tied to a valid V_{IH} level, WAIT signal can be floated and ADV# must be tied to ground. Array data is driven onto DQ[15:0] after an initial access time t_{AVQV} delay. (see [Section 7.0, "AC Characteristics" on page 26](#)).

In asynchronous page mode, four data words are "sensed" simultaneously from the flash memory array and loaded into an internal page buffer. The buffer word corresponding to the initial address on A[MAX:0] is driven onto DQ[15:0] after the initial access delay. Address bits A[MAX:2] select the 4-word page. Address bits A[1:0] determine which word of the 4-word page is output from the data buffer at any given time.

10.2 Synchronous Burst Read Mode

Read Configuration Register bits RCR[15:0] must be set before synchronous burst operation can be performed. Synchronous burst mode can be performed for both array and non-array reads such as Read ID, Read Status or Read Query (See for details).

Synchronous burst mode outputs 4, 8, 16, or . To perform a synchronous burst- read, an initial address is driven onto A[MAX:0], and CE# and OE# are asserted. WE# and RST# must be deasserted. ADV# is asserted, and then deasserted to latch the address. Alternately, ADV# can remain asserted throughout the burst access, in which case the address is latched on the next valid CLK edge after ADV# is asserted. See [Section 14.0, "Set Read Configuration Register" on page 78](#)

During synchronous array and non-array read modes, the first word is output from the data buffer on the next valid CLK edge after the initial access latency delay (see [Section 14.2, "First Access Latency Count \(RCR\[13:11\]\)" on page 79](#)). Subsequent data is

output on valid CLK edges following a minimum delay. However, for a synchronous non-array read, the same word of data will be output on successive clock edges until the burst length requirements are satisfied. See During synchronous read operations, WAIT indicates invalid data when asserted, and valid data when deasserted with respect to a valid clock edge. See Section 7.0, “AC Characteristics” on page 26 for additional details.

10.3 Read Array

The Read Array command places (or resets) the partition in read-array mode and is used to read data from the flash memory array. Upon initial device power-up, or after reset (RST# transitions from V_{IL} to V_{IH}), all partitions default to asynchronous read-array mode. To read array data from the flash device, first write the Read Array command (FFh) to the CUI and specify the desired word address. Then read from that address. If a partition is already in read-array mode, issuing the Read Array command is not required to read from that partition.

If the Read Array command is written to a partition that is erasing or programming, the device presents invalid data on the bus until the program or erase operation completes. After the program or erase finishes in that partition, valid array data can then be read. If an Erase Suspend or Program Suspend command suspends the WSM, a subsequent Read Array command places the addressed partition in read-array mode. The Read Array command functions independently of V_{pp}.

10.4 Read Identifier

The Read Identifier mode outputs the manufacturer/device identifier, block lock status, protection register codes, and Configuration Register data. The identifier information is contained within a separate memory space on the device and can be accessed along the 4-Mbit partition address range supplied by the Read Identifier command (90h) address. Reads from addresses in Table 24 retrieve ID information. Issuing a Read Identifier command to a partition that is programming or erasing places that partition’s outputs in read ID mode while the partition continues to program or erase in the background.

Table 24: Device Identification Codes (Sheet 1 of 2)

Item	Address ¹		Data	Description
	Base	Offset		
Manufacturer ID	Partition	00h	0089h	Numonyx
Device ID	Partition	01h	8862h	32-Mbit, Top Parameter Device
			8863h	32-Mbit, Bottom Parameter Device
			8864h	64-Mbit, Top Parameter Device
			8865h	64-Mbit, Bottom Parameter Device
			8866h	128-Mbit, Top Parameter Device
			8867h	128-Mbit, Bottom Parameter Device
Block Lock Status ⁽²⁾	Block	02h	D0 = 0	Block is unlocked
			D0 = 1	Block is locked
Block Lock-Down Status ⁽²⁾	Block	02h	D1 = 0	Block is not locked-down
			D1 = 1	Block is locked down
Configuration Register	Partition	05h	Register Data	

Table 24: Device Identification Codes (Sheet 2 of 2)

Item	Address ¹		Data	Description
	Base	Offset		
Protection Register Lock Status	Partition	80h	Lock Data	
Protection Register	Partition	81h - 88h	Register Data	Multiple reads required to read the entire 128-bit Protection Register.

Notes:

1. The address is constructed from a base address plus an offset. For example, to read the Block Lock Status for block number 38 in a BPD, set the address to the BBA (0F8000h) plus the *offset* (02h), i.e. 0F8002h. Then examine bit 0 of the data to determine if the block is locked.
2. See [Section 13.1.4, "Block Lock Status" on page 73](#) for valid lock status.

10.5 CFI Query

This device contains a separate CFI query *database* that acts as an "on-chip datasheet." The CFI information within this device can be accessed by issuing the Read Query command and supplying a specific address. The address is constructed from the base address of a partition plus a particular offset corresponding to the desired CFI field. [Appendix B, "Common Flash Interface \(CFI\)" on page 89](#) shows accessible CFI fields and their address offsets.

Issuing the Read Query command to a partition that is programming or erasing puts that partition in read query mode while the partition continues to program or erase in the background.

10.6 Read Status Register

The device's Status Register displays program and erase operation status. A partition's status can be read after writing the Read Status Register command to any location within the partition's address range. Read-status mode is the default read mode following a Program, Erase, or Lock Block command sequence. Subsequent single reads from that partition will return its status until another valid command is written.

The read-status mode supports single synchronous and single asynchronous reads only; it doesn't support burst reads. The first falling edge of OE# or CE# latches and updates Status Register data. The operation doesn't affect other partitions' modes. Because the Status Register is 8 bits wide, only DQ [7:0] contains valid Status Register data; DQ [15:8] contains zeros. See [Table 25, "Status Register Definitions" on page 57](#) and [Table 26, "Status Register Descriptions" on page 58](#).

Each 4-Mbit partition contains its own Status Register. Bits SR[6:0] are unique to each partition, but SR[7], the Device WSM Status (DWS) bit, pertains to the entire device. SR[7] provides program and erase status of the entire device. By contrast, the Partition WSM Status (PWS) bit, SR[0], provides program and erase status of the *addressed partition* only. Status register bits SR[6:1] present information about partition-specific program, erase, suspend, V_{pp}, and block-lock states. [Table 27, "Status Register Device WSM and Partition Write Status Description" on page 58](#) presents descriptions of DWS (SR[7]) and PWS (SR[0]) combinations.

Table 25: Status Register Definitions

DWS	ESS	ES	PS	VPPS	PSS	DPS	PWS
7	6	5	4	3	2	1	0

Table 26: Status Register Descriptions

Bit	Name	State	Description
7	DWS Device WSM Status	0 = Device WSM is Busy 1 = Device WSM is Ready	SR[7] indicates erase or program completion in the device. SR[6:1] are invalid while SR[7] = 0. See Table 27 for valid SR[7] and SR[0] combinations.
6	ESS Erase Suspend Status	0 = Erase in progress/completed 1 = Erase suspended	After issuing an Erase Suspend command, the WSM halts and sets SR[7] and SR[6]. SR[6] remains set until the device receives an Erase Resume command.
5	ES Erase Status	0 = Erase successful 1 = Erase error	SR[5] is set if an attempted erase failed. A Command Sequence Error is indicated when SR[7,5:4] are set.
4	PS Program Status	0 = Program successful 1 = Program error	SR[4] is set if the WSM failed to program a word.
3	VPPS VPP Status	0 = V _{pp} OK 1 = V _{pp} low detect, operation aborted	The WSM indicates the V _{pp} level after program or erase completes. SR[3] does not provide continuous V _{pp} feedback and isn't guaranteed when V _{pp} ≠ V _{pp1/2} .
2	PSS Program Suspend Status	0 = Program in progress/completed 1 = Program suspended	After receiving a Program Suspend command, the WSM halts execution and sets SR[7] and SR[2]. They remain set until a Resume command is received.
1	DPS Device Protect Status	0 = Unlocked 1 = Aborted erase/program attempt on locked block	If an erase or program operation is attempted to a locked block (if WP# = V _{IL}), the WSM sets SR[1] and aborts the operation.
0	PWS Partition Write Status	0 = This partition is busy, but only if SR[7]=0 1 = Another partition is busy, but only if SR[7]=0	Addressed partition is erasing or programming. In EFP mode, SR[0] indicates that a data-stream word has finished programming or verifying depending on the particular EFP phase. See Table 27 for valid SR[7] and SR[0] combinations.

Table 27: Status Register Device WSM and Partition Write Status Description

DWS (SR[7])	PWS (SR[0])	Description
0	0	The addressed partition is performing a program/erase operation. EFP: device has finished programming or verifying data, or is ready for data.
0	1	A partition other than the one currently addressed is performing a program/erase operation. EFP: the device is either programming or verifying data.
1	0	No program/erase operation is in progress in any partition. Erase and Program suspend bits (SR[6,2]) indicate whether other partitions are suspended. EFP: the device has exited EFP mode.
1	1	Won't occur in standard program or erase modes. EFP: this combination does not occur.

10.7 Clear Status Register

The Clear Status Register command clears the Status Register and leaves all partition output states unchanged. The WSM can set all Status Register bits and clear bits SR[7:6,2,0]. Because bits SR[5,4,3,1] indicate various error conditions, they can only be cleared by the Clear Status Register command. By allowing system software to reset these bits, several operations (such as cumulatively programming several addresses or erasing multiple blocks in sequence) can be performed before reading the Status Register to determine error occurrence. If an error is detected, the Status Register must be cleared before beginning another command or sequence. Device reset (RST# = V_{IL}) also clears the Status Register. This command functions independently of V_{pp}.

11.0 Program Operations

11.1 Word Program

When the Word Program command is issued, the WSM executes a sequence of internally timed events to program a word at the desired address and verify that the bits are sufficiently programmed. Programming the flash array changes specifically addressed bits to 0; 1 bits do not change the memory cell contents.

Programming can occur in only one partition at a time. All other partitions must be in either a read mode or erase suspend mode. Only one partition can be in erase suspend mode at a time.

The Status Register can be examined for program progress by reading any address within the partition that is busy programming. However, while most Status Register bits are partition-specific, the Device WSM Status bit, SR[7], is *device*-specific; that is, if the Status Register is read from any other partition, SR[7] indicates program status of the entire device. This permits the system CPU to monitor program progress while reading the status of other partitions.

CE# or OE# toggle (during polling) updates the Status Register. Several commands can be issued to a partition that is programming: Read Status Register, Program Suspend, Read Identifier, and Read Query. The Read Array command can also be issued, but the read data is indeterminate.

After programming completes, three Status Register bits can signify various possible error conditions. SR[4] indicates a program failure if set. If SR[3] is set, the WSM couldn't execute the Word Program command because V_{pp} was outside acceptable limits. If SR[1] is set, the program was aborted because the WSM attempted to program a locked block.

After the Status Register data is examined, clear it with the Clear Status Register command before a new command is issued. The partition remains in Status Register mode until another command is written to that partition. Any command can be issued after the Status Register indicates program completion.

If CE# is deasserted while the device is programming, the devices will not enter standby mode until the program operation completes.

Figure 26: Word Program Flowchart

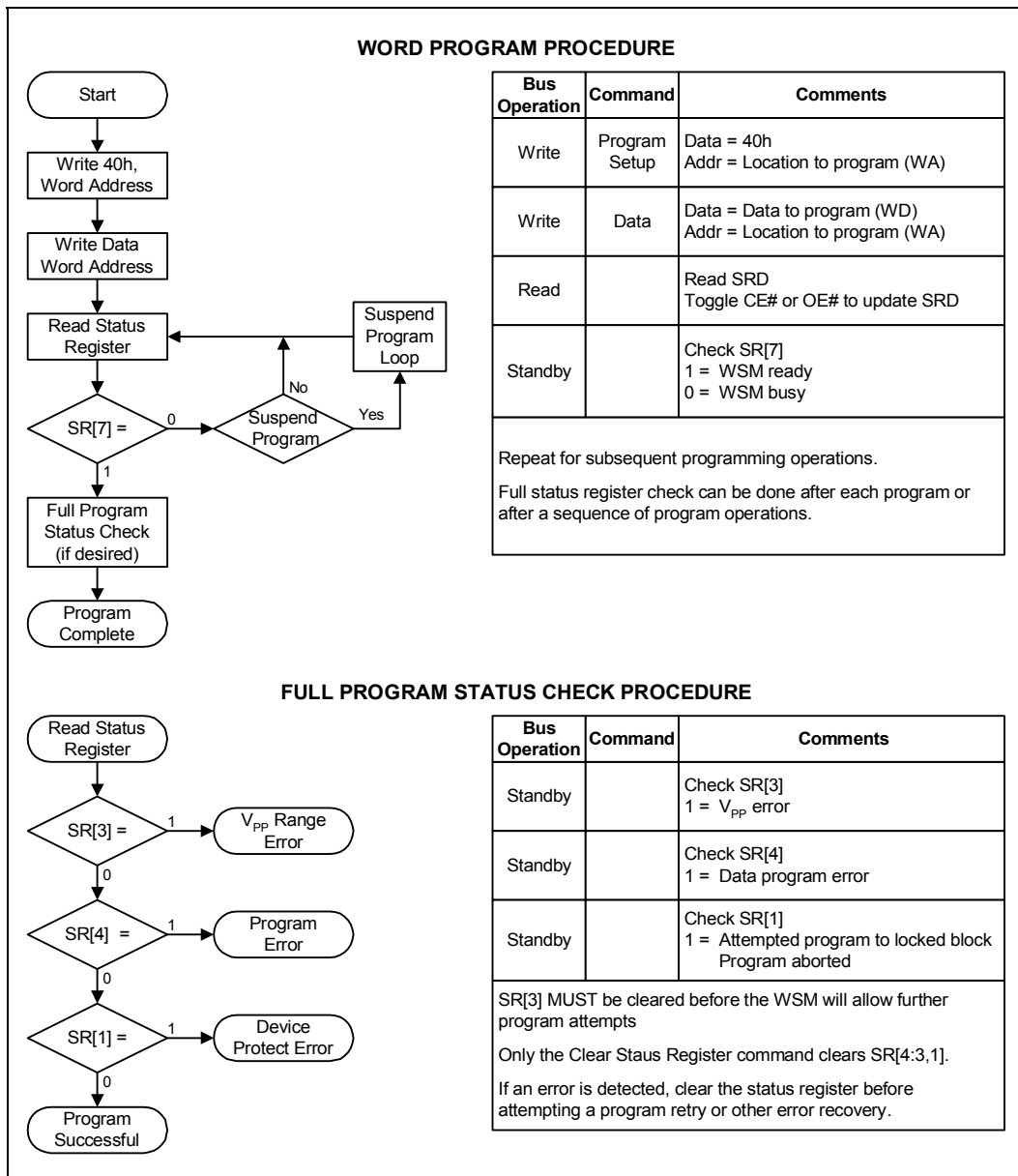

11.2 Factory Programming

The standard factory programming mode uses the same commands and algorithm as the Word Program mode (40h/10h). When V_{pp} is at V_{pp1}, program and erase currents are drawn through VCC. If VPP is driven by a logic signal, V_{pp1} must remain above the V_{pp1}Min value to perform in-system flash modifications. When VPP is connected to a 12 V power supply, the device draws program and erase current directly from VPP. This eliminates the need for an external switching transistor to control the V_{pp} voltage. [Figure 35, "Examples of VPP Power Supply Configurations" on page 77](#) shows examples of flash power supply usage in various configurations.

The 12-V V_{pp} mode enhances programming performance during the short time period typically found in manufacturing processes; however, it is not intended for extended use. 12 V may be applied to V_{pp} during program and erase operations as specified in Section 5.0, “Maximum Ratings and Operating Conditions” on page 21. V_{pp} may be connected to 12 V for a total of t_{ppH} hours maximum. Stressing the device beyond these limits may cause permanent damage.

11.3 Enhanced Factory Program (EFP)

EFP substantially improves device programming performance through a number of enhancements to the conventional 12 Volt word program algorithm. EFP's more efficient WSM algorithm eliminates the traditional overhead delays of the conventional word program mode in both the host programming system and the flash device. Changes to the conventional word programming flowchart and internal WSM routine were developed because of today's beat-rate-sensitive manufacturing environments; a balance between programming speed and cycling performance was attained.

The host programmer writes data to the device and checks the Status Register to determine when the data has completed programming. This modification essentially cuts write bus cycles in half. Following each internal program pulse, the WSM increments the device's address to the next physical location. Now, programming equipment can sequentially stream program data throughout an entire block without having to setup and present each new address. In combination, these enhancements reduce much of the host programmer overhead, enabling more of a data streaming approach to device programming.

EFP further speeds up programming by performing internal code verification. With this, PROM programmers can rely on the device to verify that it has been programmed properly. From the device side, EFP streamlines internal overhead by eliminating the delays previously associated to switch voltages between programming and verify levels at each memory-word location.

EFP consists of four phases: setup, program, verify and exit. Refer to Figure 27, “Enhanced Factory Program Flowchart” on page 64 for a detailed graphical representation of how to implement EFP.

11.3.1 EFP Requirements and Considerations

EFP Requirements	Ambient temperature: $T_A = 25\text{ }^\circ\text{C} \pm 5\text{ }^\circ\text{C}$
	V_{CC} within specified operating range
	V_{pp} within specified V_{pp2} range
	Target block unlocked
EFP Considerations	Block cycling below 100 erase cycles ¹
	RWW not supported ²
	EFP programs one block at a time
	EFP cannot be suspended

Notes:

1. Recommended for optimum performance. Some degradation in performance may occur if this limit is exceeded, but the internal algorithm will continue to work properly.
2. Code or data cannot be read from another partition during EFP.

11.3.2 Setup

After receiving the EFP Setup (30h) and EFP Confirm (D0h) command sequence, SR[7] transitions from a 1 to a 0 indicating that the WSM is busy with EFP algorithm startup. A delay before checking SR[7] is required to allow the WSM time to perform all of its setups and checks (V_{pp} level and block lock status). If an error is detected, Status Register bits SR[4], SR[3], and/or SR[1] are set and EFP operation terminates.

Note: After the EFP Setup and Confirm command sequence, reads from the device automatically output Status Register data. Do not issue the Read Status Register command; it will be interpreted as data to program at WA_0 .

11.3.3 Program

After setup completion, the host programming system must check SR[0] to determine "data-stream ready" status (SR[0]=0). Each subsequent write after this is a program-data write to the flash array. Each cell within the memory word to be programmed to 0 receives one WSM pulse; additional pulses, if required, occur in the verify phase. SR[0]=1 indicates that the WSM is busy applying the program pulse.

The host programmer must poll the device's Status Register for the "program done" state after each data-stream write. SR[0]=0 indicates that the appropriate cell(s) within the accessed memory location have received their single WSM program pulse, and that the device is now ready for the next word. Although the host may check full status for errors at any time, it is only necessary on a block basis, after EFP exit.

Addresses must remain within the target block. Supplying an address outside the target block immediately terminates the program phase; the WSM then enters the EFP verify phase.

The address can either hold constant or it can increment. The device compares the incoming address to that stored from the setup phase (WA_0); if they match, the WSM programs the new data word at the next sequential memory location. If they differ, the WSM jumps to the new address location.

The program phase concludes when the host programming system writes to a different block address, and data supplied must be FFFFh. Upon program phase completion, the device enters the EFP verify phase.

11.3.4 Verify

A high percentage of the flash bits program on the first WSM pulse. However, for those cells that do not completely program on their first attempt, EFP internal verification identifies them and applies additional pulses as required.

The verify phase is identical in flow to the program phase, except that instead of programming incoming data, the WSM compares the verify-stream data to that which was previously programmed into the block. If the data compares correctly, the host programmer proceeds to the next word. If not, the host waits while the WSM applies an additional pulse(s).

The host programmer must reset its initial verify-word address to the same starting location supplied during the program phase. It then reissues each data word in the same order as during the program phase. Like programming, the host may write each subsequent data word to WA_0 or it may increment up through the block addresses.

The verification phase concludes when the interfacing programmer writes to a different block address; data supplied must be FFFFh. Upon completion of the verify phase, the device enters the EFP exit phase.

11.3.5 Exit

SR[7]=1 indicates that the device has returned to normal operating conditions. A full status check should be performed at this time to ensure the entire block programmed successfully. After EFP exit, any valid CUI command can be issued.

Figure 27: Enhanced Factory Program Flowchart

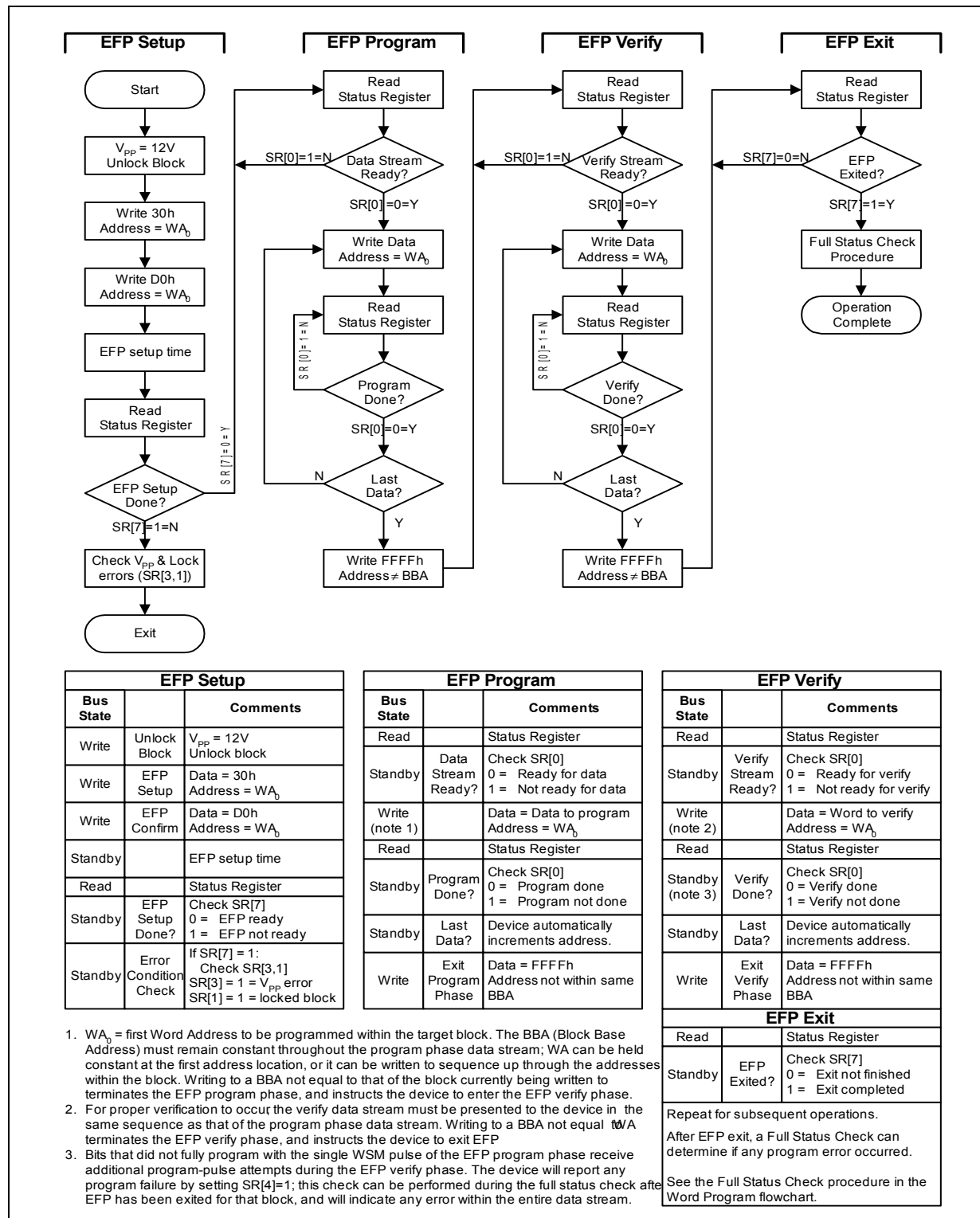

EFP Setup		
Bus State		Comments
Write	Unlock Block	V _{pp} = 12V Unlock block
Write	EFP Setup	Data = 30h Address = WA ₀
Write	EFP Confirm	Data = D0h Address = WA ₀
Standby		EFP setup time
Read		Status Register
Standby	EFP Setup Done?	Check SR[7] 0 = EFP ready 1 = EFP not ready
Standby	Error Condition Check	If SR[7] = 1: Check SR[3,1] SR[3] = 1 = V _{pp} error SR[1] = 1 = locked block

EFP Program		
Bus State		Comments
Read		Status Register
Standby	Data Stream Ready?	Check SR[0] 0 = Ready for data 1 = Not ready for data
Write (note 1)		Data = Data to program Address = WA ₀
Read		Status Register
Standby	Program Done?	Check SR[0] 0 = Program done 1 = Program not done
Standby	Last Data?	Device automatically increments address.
Write	Exit Program Phase	Data = FFFFh Address not within same BBA

EFP Verify		
Bus State		Comments
Read		Status Register
Standby	Verify Stream Ready?	Check SR[0] 0 = Ready for verify 1 = Not ready for verify
Write (note 2)		Data = Word to verify Address = WA ₀
Read		Status Register
Standby (note 3)	Verify Done?	Check SR[0] 0 = Verify done 1 = Verify not done
Standby	Last Data?	Device automatically increments address.
Write	Exit Verify Phase	Data = FFFFh Address not within same BBA

EFP Exit		
Bus State		Comments
Read		Status Register
Standby	EFP Exited?	Check SR[7] 0 = Exit not finished 1 = Exit completed
Repeat for subsequent operations. After EFP exit, a Full Status Check can determine if any program error occurred. See the Full Status Check procedure in the Word Program flowchart.		

1. WA₀ = first Word Address to be programmed within the target block. The BBA (Block Base Address) must remain constant throughout the program phase data stream; WA can be held constant at the first address location, or it can be written to sequence up through the addresses within the block. Writing to a BBA not equal to that of the block currently being written to terminates the EFP program phase, and instructs the device to enter the EFP verify phase.
2. For proper verification to occur the verify data stream must be presented to the device in the same sequence as that of the program phase data stream. Writing to a BBA not equal to WA terminates the EFP verify phase, and instructs the device to exit EFP.
3. Bits that did not fully program with the single WSM pulse of the EFP program phase receive additional program-pulse attempts during the EFP verify phase. The device will report any program failure by setting SR[4]=1; this check can be performed during the full status check after EFP has been exited for that block, and will indicate any error within the entire data stream.

12.0 Program and Erase Operations

12.1 Program/Erase Suspend and Resume

The Program Suspend and Erase Suspend commands halt an in-progress program or erase operation. The command can be issued at any device address. The partition corresponding to the command's address remains in its previous state. A suspend command allows data to be accessed from memory locations other than the one being programmed or the block being erased.

A program operation can be suspended only to perform a read operation. An erase operation can be suspended to perform either a program or a read operation within any block, except the block that is erase suspended. A program command nested within a suspended erase can subsequently be suspended to read yet another location. Once a program or erase process starts, the Suspend command requests that the WSM suspend the program or erase sequence at predetermined points in the algorithm. The partition that is actually suspended continues to output Status Register data after the Suspend command is written. An operation is suspended when status bits SR[7] and SR[6] and/or SR[2] are set.

To read data from blocks within the partition (other than an erase-suspended block), you can write a Read Array command. Block erase cannot resume until the program operations initiated during erase suspend are complete. Read Array, Read Status Register, Read Identifier (ID), Read Query, and Program Resume are valid commands during Program or Erase Suspend. Additionally, Clear Status Register, Program, Program Suspend, Erase Resume, Lock Block, Unlock Block, and Lock-Down Block are valid commands during erase suspend.

To read data from a block in a partition that is not programming or erasing, the operation does not need to be suspended. If the other partition is already in Read Array, ID, or Query mode, issuing a valid address returns corresponding data. If the other partition is not in a read mode, one of the read commands must be issued to the partition before data can be read.

During a suspend, $CE\# = V_{IH}$ places the device in standby state, which reduces active current. V_{pp} must remain at its program level and $WP\#$ must remain unchanged while in suspend mode.

A resume command instructs the WSM to continue programming or erasing and clears Status Register bits SR[2] (or SR[6]) and SR[7]. The Resume command can be written to any partition. When read at the partition that is programming or erasing, the device outputs data corresponding to the partition's last mode. If Status Register error bits are set, the Status Register can be cleared before issuing the next instruction. RST# must remain at V_{IH} . See [Figure 28, "Program Suspend / Resume Flowchart" on page 66](#), and [Figure 29, "Erase Suspend / Resume Flowchart" on page 67](#).

If a suspended partition was placed in Read Array, Read Status Register, ID, or Query mode during the suspend, the device remains in that mode and outputs data corresponding to that mode after the program or erase operation is resumed. After resuming a suspended operation, issue the read command appropriate to the read operation. To read status after resuming a suspended operation, issue a Read Status Register command (70h) to return the suspended partition to status mode.

Figure 28: Program Suspend / Resume Flowchart

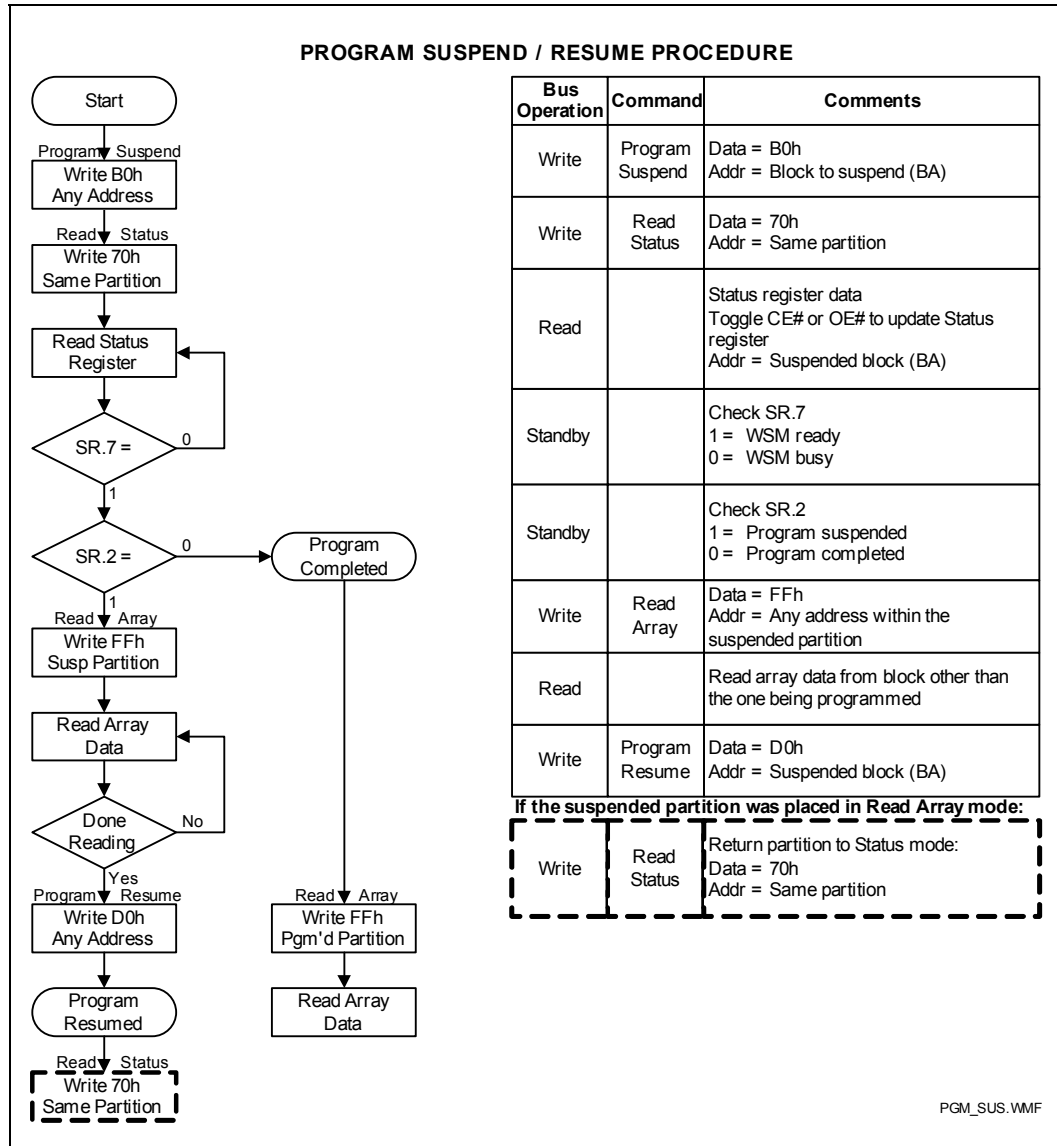
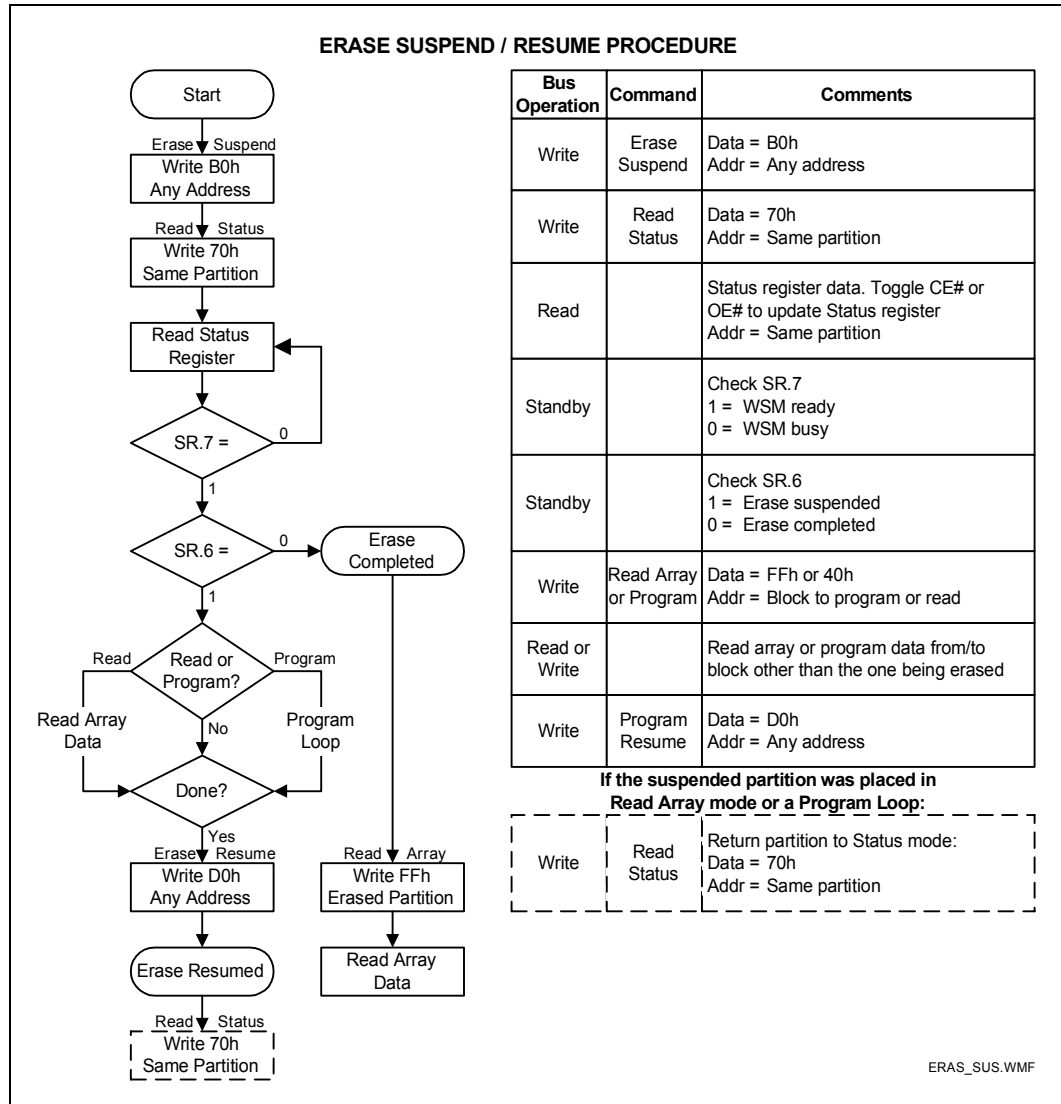

Figure 29: Erase Suspend / Resume Flowchart



12.2 Block Erase

The 2-cycle block erase command sequence, consisting of Erase Setup (20h) and Erase Confirm (D0h), initiates one block erase at the addressed block. Only one partition can be in an erase mode at a time; other partitions must be in a read mode. The Erase Confirm command internally latches the address of the block to be erased. Erase forces all bits within the block to 1. SR[7] is cleared while the erase executes.

After writing the Erase Confirm command, the selected partition is placed in read Status Register mode and reads performed to that partition return the current status data. The address given during the Erase Confirm command does not need to be the same address used in the Erase Setup command. So, if the Erase Confirm command is given to partition B, then the selected block in partition B will be erased even if the Erase Setup command was to partition A.

The 2-cycle erase sequence cannot be interrupted with a bus write operation. For example, an Erase Setup command must be immediately followed by the Erase Confirm command in order to execute properly. If a different command is issued between the setup and confirm commands, the partition is placed in read-status mode, the Status Register signals a command sequence error, and all subsequent erase commands to that partition are ignored until the Status Register is cleared.

The CPU can detect block erase completion by analyzing SR[7] of that partition. If an error bit (SR[5,3,1]) was flagged, the Status Register can be cleared by issuing the Clear Status Register command before attempting the next operation. The partition remains in read-status mode until another command is written to its CUI. Any CUI instruction can follow after erasing completes. The CUI can be set to read-array mode to prevent inadvertent Status Register reads.

Figure 30: Block Erase Flowchart

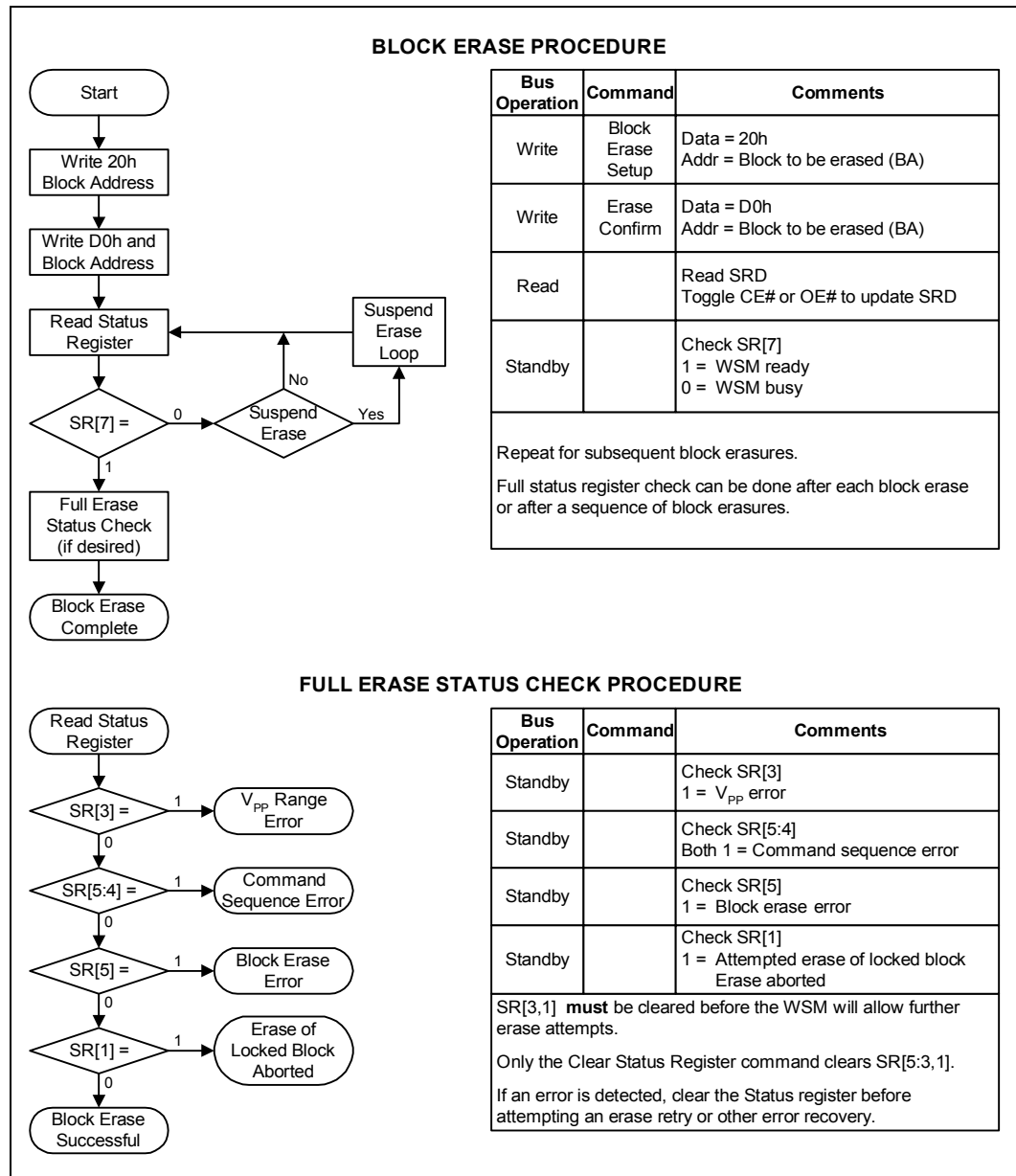

12.3 Read-While-Write and Read-While-Erase

The Numonyx™ Wireless Flash Memory (W18) supports flexible multi-partition dual-operation architecture. By dividing the flash memory into many separate partitions, the device can read from one partition while programming or erasing in another partition; hence the terms, RWW and RWE. Both of these features greatly enhance data storage performance.

The product does not support simultaneous program and erase operations. Attempting to perform operations such as these results in a command sequence error. Only one partition can be programming or erasing while another partition is reading. However, one partition may be in erase suspend mode while a second partition is performing a program operation, and yet another partition is executing a read command. [Table 22, "Command Codes and Descriptions" on page 51](#) describes the command codes available for all functions.

13.0 Security Modes

The Numonyx Wireless Flash Memory (W18) offers both hardware and software security features to protect the flash data. The software security feature is used by executing the Lock Block command. The hardware security feature is used by executing the Lock-Down Block command *and* by asserting the WP# signal.

Refer to [Figure 31, “Block Locking State Diagram” on page 72](#) for a state diagram of the flash security features. Also see [Figure 32, “Locking Operations Flowchart” on page 74](#).

13.1 Block Lock Operations

Individual instant block locking protects code and data by allowing any block to be locked or unlocked with no latency. This locking scheme offers two levels of protection. The first allows software-only control of block locking (useful for frequently changed data blocks), while the second requires hardware interaction before locking can be changed (protects infrequently changed code blocks).

The following sections discuss the locking system operation. The term “state [abc]” specifies locking states; for example, “state [001],” where a = WP# value, b = block lock-down status bit

D1, and c = Block Lock Status Register bit D0. [Figure 31, “Block Locking State Diagram” on page 72](#) defines possible locking states.

The following summarizes the locking functionality.

- All blocks power-up in a locked state.
- Unlock commands can unlock these blocks, and lock commands can lock them again.
- The Lock-Down command locks a block and prevents it from being unlocked when WP# is asserted.
 - Locked-down blocks can be unlocked or locked with commands as long as WP# is deasserted.
 - The lock-down status bit is cleared only when the device is reset or powered-down.

Block lock registers are not affected by the V_{pp} level. They may be modified and read even if $V_{pp} \leq V_{PPLK}$.

Each block’s locking status can be set to locked, unlocked, and lock-down, as described in the following sections. See [Figure 32, “Locking Operations Flowchart” on page 74](#).

Figure 31: Block Locking State Diagram

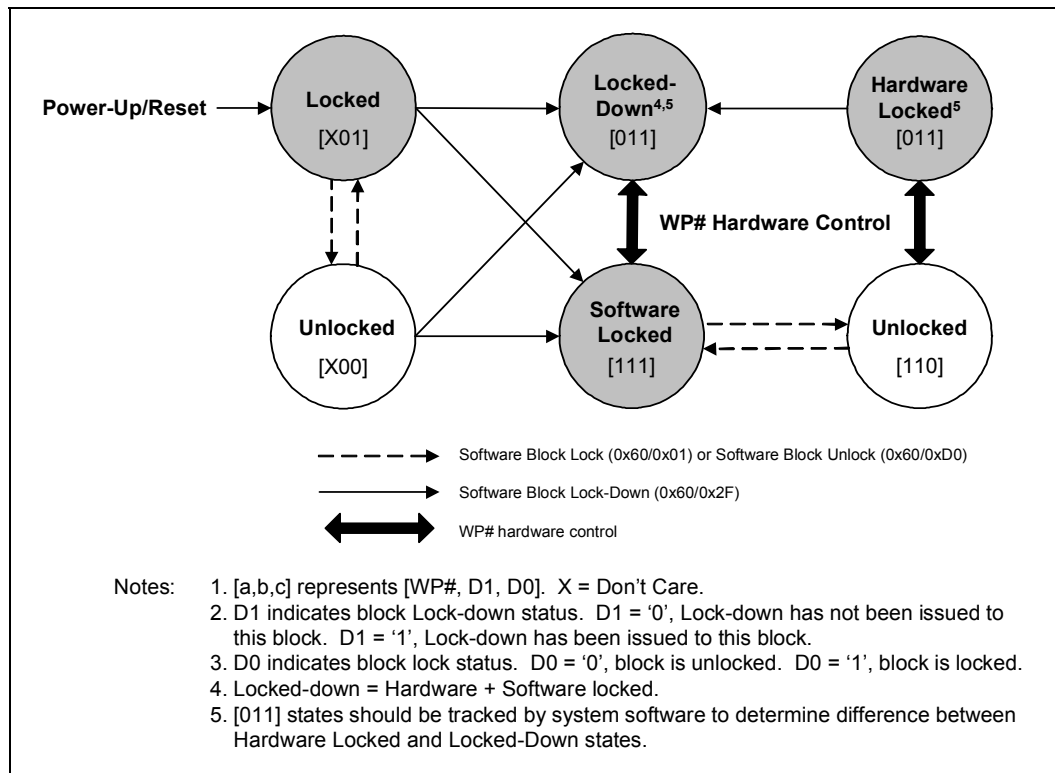

13.1.1 Lock

All blocks default to locked (state [x01]) after initial power-up or reset. Locked blocks are fully protected from alteration. Attempted program or erase operations to a locked block will return an error in SR[1]. Unlocked blocks can be locked by using the Lock Block command sequence. Similarly, a locked block's status can be changed to unlocked or lock-down using the appropriate software commands.

13.1.2 Unlock

Unlocked blocks (states [x00] and [110]) can be programmed or erased. All unlocked blocks return to the locked state when the device is reset or powered-down. An unlocked block's status can be changed to the locked or locked-down state using the appropriate software commands. A locked block can be unlocked by writing the Unlock Block command sequence if the block is not locked-down.

13.1.3 Lock-Down

Locked-down blocks (state [011]) offer the user an additional level of write protection beyond that of a regular locked block. A block that is locked-down cannot have its state changed by software if WP# is asserted. A locked or unlocked block can be locked-down by writing the Lock-Down Block command sequence. If a block was set to locked-down, then later changed to unlocked, a Lock-Down command should be issued prior asserting WP# will put that block back to the locked-down state. When WP# is deasserted, locked-down blocks are changed to the locked state and can then be unlocked by the Unlock Block command.

13.1.4 Block Lock Status

Every block’s lock status can be read in read identifier mode. To enter this mode, issue the Read Identifier command to the device. Subsequent reads at BBA + 02h will output that block’s lock status. For example, to read the block lock status of block 10, the address sent to the device should be 50002h (for a top-parameter device). The lowest two data bits of the read data, DQ1 and DQ0, represent the lock status. DQ0 indicates the block lock status. It is set by the Lock Block command and cleared by the Block Unlock command. It is also set when entering the lock-down state. DQ1 indicates lock-down status and is set by the Lock-Down command. The lock-down status bit cannot be cleared by software—only by device reset or power-down. See [Table 28](#).

Table 28: Write Protection Truth Table

VPP	WP#	RST#	Write Protection
X	X	V _{IL}	Device inaccessible
V _{IL}	X	V _{IH}	Word program and block erase prohibited
X	V _{IL}	V _{IH}	All lock-down blocks locked
X	V _{IH}	V _{IH}	All lock-down blocks can be unlocked

13.1.5 Lock During Erase Suspend

Block lock configurations can be performed during an erase suspend operation by using the standard locking command sequences to unlock, lock, or lock-down a block. This feature is useful when another block requires immediate updating.

To change block locking during an erase operation, first write the Erase Suspend command. After checking SR[6] to determine the erase operation has suspended, write the desired lock command sequence to a block; the lock status will be changed. After completing lock, unlock, read, or program operations, resume the erase operation with the Erase Resume command (D0h).

If a block is locked or locked-down during a suspended erase of the same block, the locking status bits change immediately. When the erase operation is resumed, it will complete normally.

Locking operations cannot occur during program suspend. [Appendix A, “Write State Machine States” on page 86](#) shows valid commands during erase suspend.

13.1.6 Status Register Error Checking

Using nested locking or program command sequences during erase suspend can introduce ambiguity into Status Register results.

Because locking changes require 2-cycle command sequences, for example, 60h followed by 01h to lock a block, following the Configuration Setup command (60h) with an invalid command produces a command sequence error (SR[5:4]=11b). If a Lock Block command error occurs during erase suspend, the device sets SR[4] and SR[5] to 1 even after the erase is resumed. When erase is complete, possible errors during the erase cannot be detected from the Status Register because of the previous locking command error. A similar situation occurs if a program operation error is nested within an erase suspend.

13.1.7 WP# Lock-Down Control

The Write Protect signal, WP#, adds an additional layer of block security. WP# only affects blocks that once had the Lock-Down command written to them. After the lock-down status bit is set for a block, asserting WP# forces that block into the lock-down state [011] and prevents it from being unlocked. After WP# is deasserted, the block's state reverts to locked [111] and software commands can then unlock the block (for erase or program operations) and subsequently re-lock it. Only device reset or power-down can clear the lock-down status bit and render WP# ineffective.

Figure 32: Locking Operations Flowchart

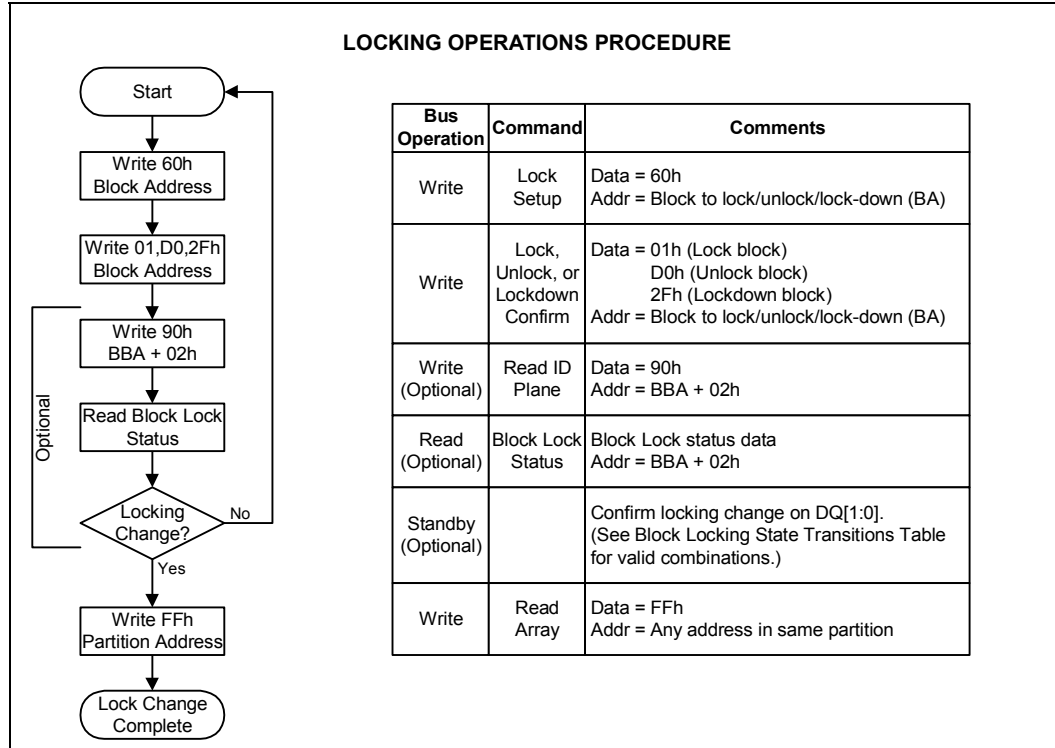

13.2 Protection Register

The Numonyx Wireless Flash Memory (W18) includes a 128-bit Protection Register. This protection register is used to increase system security and for identification purposes. The protection register value can match the flash component to the system's CPU or ASIC to prevent device substitution.

The lower 64 bits within the protection register are programmed by Numonyx with a unique number in each flash device. The upper 64 OTP bits within the protection register are left for the customer to program. Once programmed, the customer segment can be locked to prevent further programming.

Note:

The individual bits of the user segment of the protection register are OTP, not the register in total. The user may program each OTP bit individually, one at a time, if desired. After the protection register is locked, however, the entire user segment is locked and no more user bits can be programmed.

The protection register shares some of the same internal flash resources as the parameter partition. Therefore, RWW is only allowed between the protection register and main partitions. Table 29 describes the operations allowed in the protection register, parameter partition, and main partition during RWW and RWE.

Table 29: Simultaneous Operations Allowed with the Protection Register

Protection Register	Parameter Partition Array Data	Main Partitions	Description
Read	See Description	Write/Erase	While programming or erasing in a main partition, the protection register can be read from any other partition. Reading the parameter partition data is not allowed if the protection register is being read from addresses within the parameter partition.
See Description	Read	Write/Erase	While programming or erasing in a main partition, read operations are allowed in the parameter partition. Accessing the protection registers from parameter partition addresses is not allowed.
Read	Read	Write/Erase	While programming or erasing in a main partition, read operations are allowed in the parameter partition. Accessing the protection registers in a partition that is <i>different</i> from the one being programmed or erased, and also <i>different</i> from the parameter partition, is allowed.
Write	No Access Allowed	Read	While programming the protection register, reads are only allowed in the other main partitions. Access to the parameter partition is not allowed. This is because programming of the protection register can only occur in the parameter partition, so it will exist in status mode.
No Access Allowed	Write/Erase	Read	While programming or erasing the parameter partition, reads of the protection registers are not allowed in <i>any</i> partition. Reads in other main partitions are supported.

13.2.1 Reading the Protection Register

Writing the Read Identifier command allows the protection register data to be read 16 bits at a time from addresses shown in Table 24, “Device Identification Codes” on page 56. The protection register is read from the Read Identifier command and can be read in any partition. Writing the Read Array command returns the device to read-array mode.

13.2.2 Programming the Protection Register

The Protection Program command should be issued only at the parameter (top or bottom) partition followed by the data to be programmed at the specified location. It programs the upper 64 bits of the protection register 16 bits at a time. Table 24, “Device Identification Codes” on page 56 shows allowable addresses. See also Figure 33, “Protection Register Programming Flowchart” on page 76. Issuing a Protection Program command outside the register’s address space results in a Status Register error (SR[4]=1).

13.2.3 Locking the Protection Register

PR-LK.0 is programmed to 0 by Numonyx to protect the unique device number. PR-LK.1 can be programmed by the user to lock the user portion (upper 64 bits) of the protection register (See Figure 34, “Protection Register Locking”). This bit is set using the Protection Program command to program “FFFDh” into PR-LK.

After PR-LK register bits are programmed (locked), the protection register’s stored values can’t be changed. Protection Program commands written to a locked section result in a Status Register error (SR[4]=1, SR[5]=1).

Figure 33: Protection Register Programming Flowchart

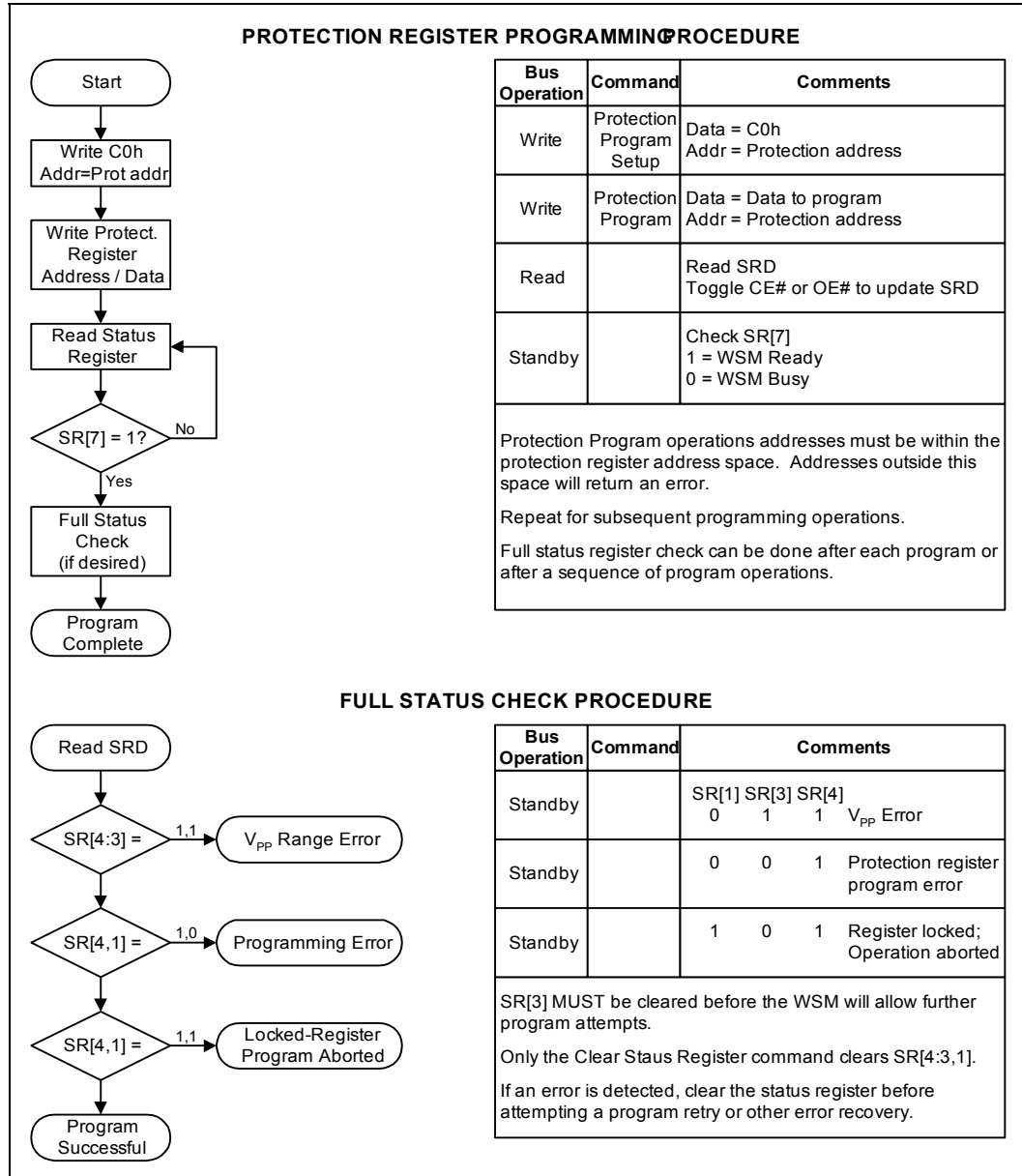
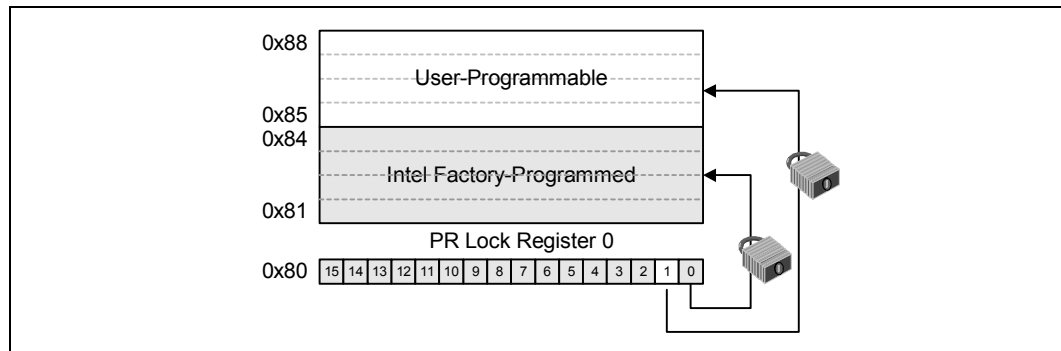

Figure 34: Protection Register Locking



13.3 VPP Protection

The Numonyx™ Wireless Flash Memory (W18) provides in-system program and erase at V_{PP1} . For factory programming, it also includes a low-cost, backward-compatible 12 V programming feature. (Section 11.2, “Factory Programming” on page 60) The EFP feature can also be used to greatly improve factory program performance as explained in Section 11.3, “Enhanced Factory Program (EFP)” on page 61.

In addition to the flexible block locking, holding the V_{PP} programming voltage low can provide absolute hardware write protection of all flash-device blocks. If V_{PP} is below V_{PPLK} , program or erase operations result in an error displayed in SR[3]. (See Figure 35.)

Figure 35: Examples of VPP Power Supply Configurations

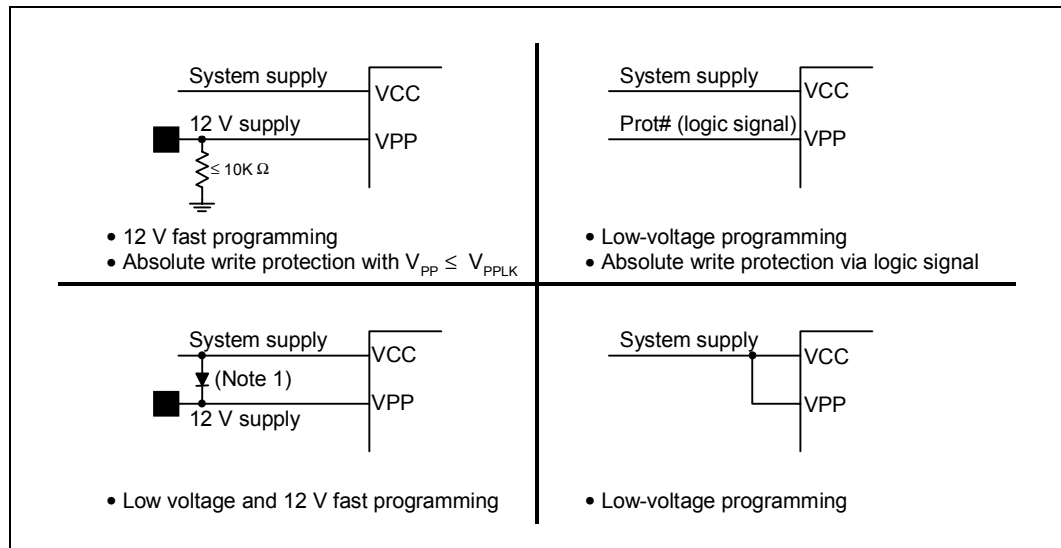

Note: If the V_{CC} supply can sink adequate current, you can use an appropriately valued resistor.

14.0 Set Read Configuration Register

The Set Read Configuration Register (RCR) command sets the burst order, frequency configuration, burst length, and other parameters.

A two-bus cycle command sequence initiates this operation. The Read Configuration Register data is placed on the lower 16 bits of the address bus (A[15:0]) during both bus cycles. The Set Read Configuration Register command is written along with the configuration data (on the address bus). This is followed by a second write that confirms the operation and again presents the Read Configuration Register data on the address bus. The Read Configuration Register data is latched on the rising edge of ADV#, CE#, or WE# (whichever occurs first). This command functions independently of the applied V_{pp} voltage. After executing this command, the device returns to read-array mode. The Read Configuration Register's contents can be examined by writing the Read Identifier command and then reading location 05h. See [Table 30](#) and [Table 31](#).

Table 30: Read Configuration Register Summary

Read Mode	Res'd	First Access Latency Count			WAIT Polarity	Data Output Config	WAIT Config	Burst Seq	Clock Config	Res'd	Res'd	Burst Wrap	Burst Length		
		LC2	LC1	LC0									BL2	BL1	BLO
RM	R	LC2	LC1	LC0	WT	DOC	WC	BS	CC	R	R	BW	BL2	BL1	BLO
15	14	13	12	11	10	9	8	7	6	5	4	3	2	1	0

Table 31: Read Configuration Register Descriptions (Sheet 1 of 2)

Bit	Name	Description ¹	Notes
15	RM Read Mode	0 = Synchronous Burst Reads Enabled 1 = Asynchronous Reads Enabled (Default)	2
14	R	Reserved	5
13-11	LC[2:0] First Access Latency Count	001 = Reserved 100 = Code 4 010 = Code 2 101 = Code 5 011 = Code 3 111 = Reserved (Default)	6
10	WT WAIT Signal Polarity	0 = WAIT signal is asserted low 1 = WAIT signal is asserted high (Default)	3
9	DOC Data Output Configuration	0 = Hold Data for One Clock 1 = Hold Data for Two Clock (Default)	6
8	WC WAIT Configuration	0 = WAIT Asserted During Delay 1 = WAIT Asserted One Data Cycle before Delay (Default)	6
7	BS Burst Sequence	1 = Linear Burst Order (Default)	
6	CC Clock Configuration	0 = Burst Starts and Data Output on Falling Clock Edge 1 = Burst Starts and Data Output on Rising Clock Edge (Default)	
5	R	Reserved	5
4	R	Reserved	5

Table 31: Read Configuration Register Descriptions (Sheet 2 of 2)

Bit	Name	Description ¹	Notes
3	BW Burst Wrap	0 = Wrap bursts within burst length set by CR[2:0] 1 = Don't wrap accesses within burst length set by CR[2:0].(Default)	
2-0	BL[2:0] Burst Length	001 = 4-Word Burst 010 = 8-Word Burst 011 = 16-Word Burst 111 = Continuous Burst (Default)	4

Notes:

1. Undocumented combinations of bits are reserved by Numonyx for future implementations.
2. Synchronous and page read mode configurations affect reads from main blocks and parameter blocks. Status Register and configuration reads support single read cycles. RCR[15]=1 disables configuration set by RCR[14:0].
3. Data is not ready when WAIT is asserted.
4. Set the synchronous burst length. In asynchronous page mode, the page size equals four words.
5. Set all reserved Read Configuration Register bits to zero.
6. Setting the Read Configuration Register for synchronous burst-mode with a latency count of 2 (RCR[13:11] = 010), data hold for 2 clocks (RCR[9] = 1), and WAIT asserted one data cycle before delay (RCR[8] = 1) is not supported.

14.1 Read Mode (RCR[15])

All partitions support two high-performance read configurations: synchronous burst mode and asynchronous page mode (default). RCR[15] sets the read configuration to one of these modes.

Status register, query, and identifier modes support only asynchronous and single-synchronous read operations.

14.2 First Access Latency Count (RCR[13:11])

The First Access Latency Count (RCR[13:11]) configuration tells the device how many clocks must elapse from ADV# de-assertion (V_{IH}) before the first data word should be driven onto its data pins. The input clock frequency determines this value. See [Table 31, "Read Configuration Register Descriptions" on page 78](#) for latency values. [Figure 36](#) shows data output latency from ADV# assertion for different latencies. Refer to [Section , "" on page 80](#) for Latency Code Settings.

Figure 36: First Access Latency Configuration

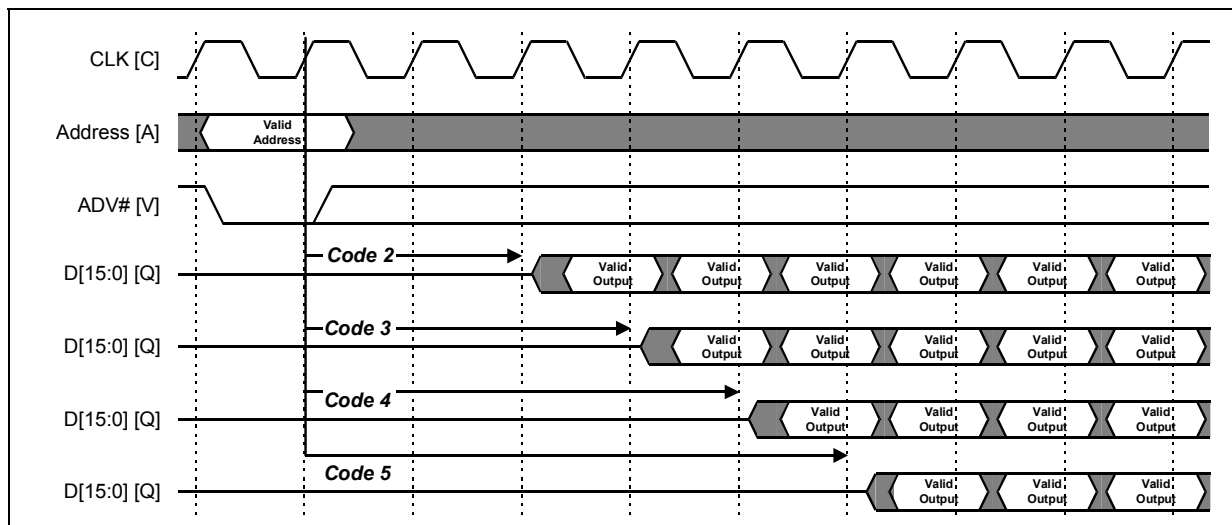

Note: Other First Access Latency Configuration settings are reserved.

Figure 37: Word Boundary

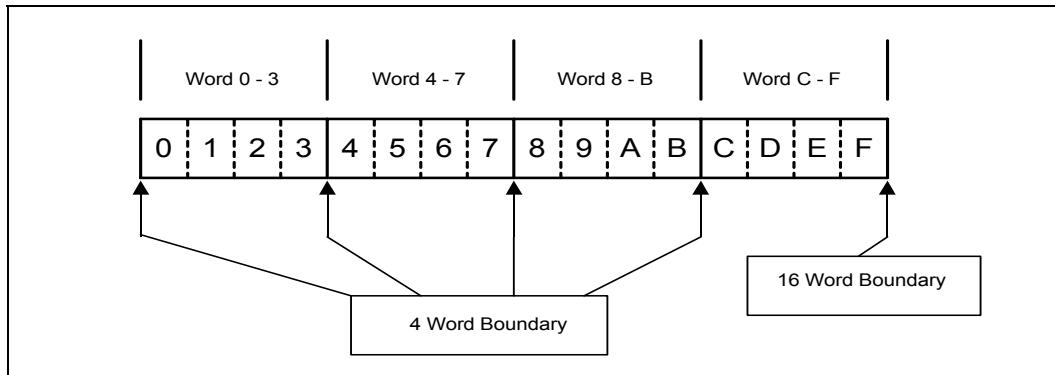

Note: The 16-word boundary is the end of the device sense word-line.

14.2.1 Latency Count Settings

Table 32: Latency Count Setting for $V_{CCQ} = 1.7\text{ V} - 1.95\text{ V}$ (90 nm)

	$V_{CCQ} = 1.7 - 1.95\text{ V}$			Unit
	t_{AVQV}/t_{CHQV} (60ns/11ns)			
Latency Count Settings	2*	3	4, 5	—
Frequency Support	≤ 40	≤ 61	≤ 66	MHz

Note: RCR bits[9:8] must be set to 0 for latency count of 2.

Table 33: Latency Count Setting for $V_{CCQ} = 1.7\text{ V} - 2.24\text{ V}$ (130 nm)

	$V_{CCQ} = 1.7 - 2.24\text{ V}$			Unit
	t_{AVQV}/t_{CHQV} (60ns/11ns)			
Latency Count Settings	2	3	4, 5	—
Frequency Support	≤ 40	≤ 61	≤ 66	MHz

Figure 38: Example: Latency Count Setting at 3

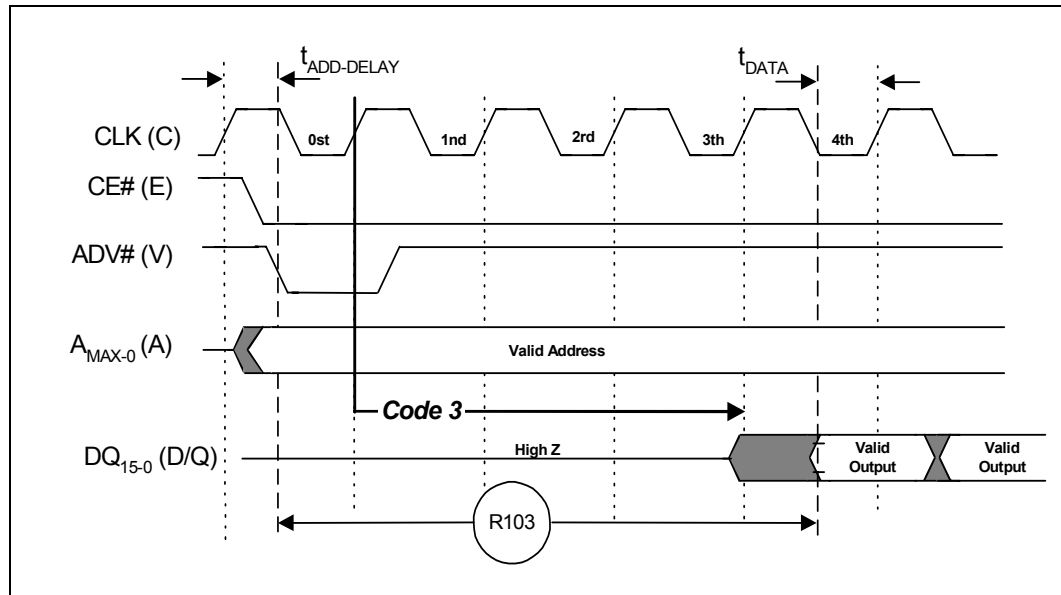

14.3 WAIT Signal Polarity (RCR[10])

If the WAIT bit is cleared (RCR[10]=0), then WAIT is configured to be asserted low. This means that a 0 on the WAIT signal indicates that data is not ready and the data bus contains invalid data. Conversely, if RCR[10] is set, then WAIT is asserted high. In either case, if WAIT is deasserted, then data is ready and valid. WAIT is asserted during asynchronous page mode reads.

14.4 WAIT Signal Function

The WAIT signal indicates data valid when the device is operating in synchronous mode (RCR[15]=0), and when addressing a partition that is currently in read-array mode. The WAIT signal is only "deasserted" when data is valid on the bus.

When the device is operating in synchronous non-read-array mode, such as read status, read ID, or read query, WAIT is set to an "asserted" state as determined by RCR[10]. See [Figure 12, "WAIT Signal in Synchronous Non-Read Array Operation Waveform" on page 35](#).

When the device is operating in asynchronous page mode or asynchronous single word read mode, WAIT is set to an "asserted" state as determined by RCR[10]. See [Figure 8, "Page-Mode Read Operation Waveform" on page 31](#), and [Figure 6, "Asynchronous Read Operation Waveform" on page 29](#).

From a system perspective, the WAIT signal is in the asserted state (based on RCR[10]) when the device is operating in synchronous non-read-array mode (such as Read ID, Read Query, or Read Status), or if the device is operating in asynchronous mode (RCR[15]=1). In these cases, the system software should ignore (mask) the WAIT signal, because it does not convey any useful information about the validity of what is appearing on the data bus.

Table 34: WAIT Signal Conditions

CONDITION	WAIT
CE# = V _{IH} CE# = V _{IL}	Tri-State Active
OE#	No-Effect
Synchronous Array Read	Active
Synchronous Non-Array Read	Asserted
All Asynchronous Read and all Write	Asserted

14.5 Data Hold (RCR[9])

The Data Output Configuration (DOC) bit (RCR[9]) determines whether a data word remains valid on the data bus for one or two clock cycles. The processor's minimum data set-up time and the flash memory's clock-to-data output delay determine whether one or two clocks are needed.

A DOC set at 1-clock data hold corresponds to a 1-clock data cycle; a DOC set at 2-clock data hold corresponds to a 2-clock data cycle. The setting of this configuration bit depends on the system and CPU characteristics. For clarification, see [Figure 39, "Data Output Configuration with WAIT Signal Delay" on page 83](#).

A method for determining this configuration setting is shown below.

To set the device at 1-clock data hold for subsequent reads, the following condition must be satisfied:

$$t_{\text{CHQV}} (\text{ns}) + t_{\text{DATA}} (\text{ns}) \leq \text{One CLK Period} (\text{ns})$$

As an example, use a clock frequency of 66 MHz and a clock period of 15 ns. Assume the data output hold time is one clock. Apply this data to the formula above for the subsequent reads:

$$11 \text{ ns} + 4 \text{ ns} \leq 15 \text{ ns}$$

This equation is satisfied, and data output will be available and valid at every clock period. If t_{DATA} is long, hold for two cycles.

During page-mode reads, the initial access time can be determined by the formula:

$$t_{\text{ADD-DELAY}} (\text{ns}) + t_{\text{DATA}} (\text{ns}) + t_{\text{AVQV}} (\text{ns})$$

Subsequent reads in page mode are defined by:

$$t_{\text{APA}} (\text{ns}) + t_{\text{DATA}} (\text{ns}) \quad (\text{minimum time})$$

Figure 39: Data Output Configuration with WAIT Signal Delay

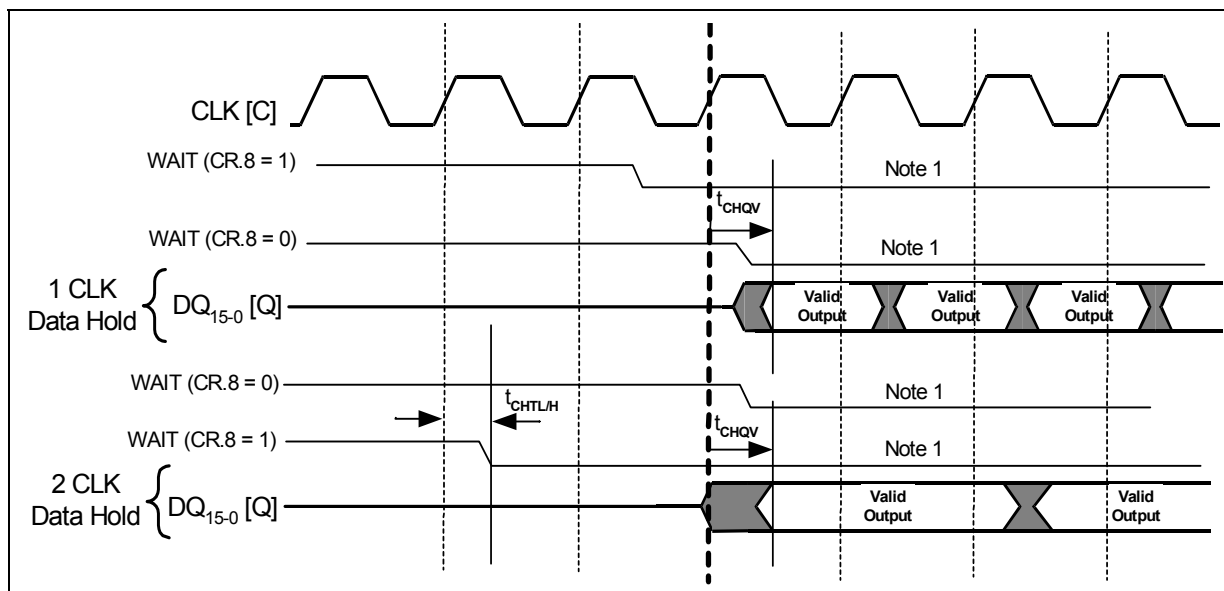

Note: WAIT shown asserted high (RCR[10]=1).

14.6 WAIT Delay (RCR[8])

The WAIT configuration bit (RCR[8]) controls WAIT signal delay behavior for all synchronous read-array modes. Its setting depends on the system and CPU characteristics. The WAIT can be asserted either during, or one data cycle before, a valid output.

In synchronous linear read array (no-wrap mode RCR[3]=1) of 4-, 8-, 16-, or continuous-word burst mode, an output delay may occur when a burst sequence crosses its first device-row boundary (16-word boundary). If the burst start address is 4-word boundary aligned, the delay does not occur. If the start address is misaligned to a 4-word boundary, the delay occurs once per burst-mode read sequence. The WAIT signal informs the system of this delay.

14.7 Burst Sequence (RCR[7])

The burst sequence specifies the synchronous-burst mode data order (see [Table 35, "Sequence and Burst Length" on page 84](#)). When operating in a linear burst mode, either 4-, 8-, or 16-word burst length with the burst wrap bit (RCR[3]) set, or in continuous burst mode, the device may incur an output delay when the burst sequence crosses the first 16-word boundary. (See [Figure 37, "Word Boundary" on page 80](#) for word boundary description.) This depends on the starting address. If the starting address is aligned to a 4-word boundary, there is no delay. If the starting address is the end of a 4-word boundary, the output delay is one clock cycle less than the First Access Latency Count; this is the worst-case delay. The delay takes place only once, and only if the burst sequence crosses a 16-word boundary. The WAIT pin informs the system of this delay. For timing diagrams of WAIT functionality, see these figures:

- [Figure 9, "Single Synchronous Read-Array Operation Waveform" on page 32](#)
- [Figure 10, "Synchronous 4-Word Burst Read Operation Waveform" on page 33](#)
- [Figure 11, "WAIT Functionality for EOWL \(End-of-Word Line\) Condition Waveform" on page 34](#)

Table 35: Sequence and Burst Length

	Start Addr. (Dec)	Burst Addressing Sequence (Decimal)			
		4-Word Burst RCR[2:0]=001b	8-Word Burst RCR[2:0]=010b	16-Word Burst RCR[2:0]=011b	Continuous Burst RCR[2:0]=111b
		Linear	Linear	Linear	Linear
Wrap (RCR[3]=0)	0	0-1-2-3	0-1-2-3-4-5-6-7	0-1-2...14-15	0-1-2-3-4-5-6-...
	1	1-2-3-0	1-2-3-4-5-6-7-0	1-2-3...14-15-0	1-2-3-4-5-6-7-...
	2	2-3-0-1	2-3-4-5-6-7-0-1	2-3-4...15-0-1	2-3-4-5-6-7-8-...
	3	3-0-1-2	3-4-5-6-7-0-1-2	3-4-5...15-0-1-2	3-4-5-6-7-8-9-...
	4		4-5-6-7-0-1-2-3	4-5-6...15-0-1-2-3	4-5-6-7-8-9-10-...
	5		5-6-7-0-1-2-3-4	5-6-7...15-0-1...4	5-6-7-8-9-10-11-...
	6		6-7-0-1-2-3-4-5	6-7-8...15-0-1...5	6-7-8-9-10-11-12-...
	7		7-0-1-2-3-4-5-6	7-8-9...15-0-1...6	7-8-9-10-11-12-13-...
	:	:	:	:	:
	14			14-15-0-1...13	14-15-16-17-18-19-20-...
	15			15-0-1-2-3...14	15-16-17-18-19-...
No-Wrap (RCR[3]=1)	0	0-1-2-3	0-1-2-3-4-5-6-7	0-1-2...14-15	0-1-2-3-4-5-6-...
	1	1-2-3-4	1-2-3-4-5-6-7-8	1-2-3...15-16	1-2-3-4-5-6-7-...
	2	2-3-4-5	2-3-4-5-6-7-8-9	2-3-4...16-17	2-3-4-5-6-7-8-...
	3	3-4-5-6	3-4-5-6-7-8-9-10	3-4-5...17-18	3-4-5-6-7-8-9-...
	4		4-5-6-7-8-9-10-11	4-5-6...18-19	4-5-6-7-8-9-10-...
	5		5-6-7-8-9-10-11-12	5-6-7...19-20	5-6-7-8-9-10-11-...
	6		6-7-8-9-10-11-12-13	6-7-8...20-21	6-7-8-9-10-11-12-...
	7		7-8-9-10-11-12-13-14	7-8-9...21-22	7-8-9-10-11-12-13-...
	:	:	:	:	:
	14			14-15...28-29	14-15-16-17-18-19-20-...
	15			15-16...29-30	15-16-17-18-19-20-21-...

14.8 Clock Edge (RCR[6])

Configuring the valid clock edge enables a flexible memory interface to a wide range of burst CPUs. Clock configuration sets the device to start a burst cycle, output data, and assert WAIT on the clock's rising or falling edge.

14.9 Burst Wrap (RCR[3])

The burst wrap bit determines whether 4-, 8-, or 16-word burst accesses wrap within the burst-length boundary or whether they cross word-length boundaries to perform linear accesses. No-wrap mode (RCR[3]=1) enables WAIT to hold off the system processor, as it does in the continuous burst mode, until valid data is available. In no-wrap mode (RCR[3]=0), the device operates similarly to continuous linear burst mode but consumes less power during 4-, 8-, or 16-word bursts.

For example, if RCR[3]=0 (wrap mode) and RCR[2:0] = 1h (4-word burst), possible linear burst sequences are 0-1-2-3, 1-2-3-0, 2-3-0-1, 3-0-1-2.

If RCR[3]=1 (no-wrap mode) and RCR[2:0] = 1h (4-word burst length), then possible linear burst sequences are 0-1-2-3, 1-2-3-4, 2-3-4-5, and 3-4-5-6. RCR[3]=1 not only enables limited non-aligned sequential bursts, but also reduces power by minimizing the number of internal read operations.

Setting RCR[2:0] bits for continuous linear burst mode (7h) also achieves the above 4-word burst sequences. However, significantly more power may be consumed. The 1-2-3-4 sequence, for example, consumes power during the initial access, again during the internal pipeline lookup as the processor reads word 2, and possibly again, depending on system timing, near the end of the sequence as the device pipelines the next 4-word sequence. RCR[3]=1 while in 4-word burst mode (no-wrap mode) reduces this excess power consumption.

14.10 Burst Length (RCR[2:0])

The Burst Length bit (BL[2:0]) selects the number of words the device outputs in synchronous read access of the flash memory array. The burst lengths are 4-word, 8-word, 16-word, and continuous word.

Continuous-burst accesses are linear only, and do not wrap within any word length boundaries (see [Table 35, "Sequence and Burst Length" on page 84](#)). When a burst cycle begins, the device outputs synchronous burst data until it reaches the end of the "burstable" address space.

Appendix A Write State Machine States

This table shows the command state transitions based on incoming commands. Only one partition can be actively programming or erasing at a time.

Figure 40: Write State Machine – Next State Table (Sheet 1 of 2)

Chip Next State after Command Input										
Write State Machine (WSM) Next State Table	Current Chip State ⁽⁸⁾	Read Array ⁽³⁾	Program Setup ^(4,5)	Erase Setup ^(4,5)	Enhanced Factory Pgm Setup ⁽⁴⁾	BE Confirm, P/E Resume, ULB Confirm ⁽⁹⁾	Program/ Erase Suspend	Read Status	Clear Status Register ⁽⁶⁾	Read ID/Query
		(FFH)	(10H/40H)	(20H)	(30H)	(D0H)	(B0H)	(70H)	(50H)	(90H, 98H)
Ready	Ready	Ready	Program Setup	Erase Setup	EFP Setup	Ready				
Lock/CR Setup		Ready (Lock Error)				Ready	Ready (Lock Error)			
OTP	Setup	OTP Busy								
	Busy	OTP Busy								
Program	Setup	Program Busy								
	Busy	Program Busy					Pgm Susp	Program Busy		
	Suspend	Program Suspend				Pgm Busy	Program Suspend			
Erase	Setup	Ready (Error)				Erase Busy	Ready (Error)			
	Busy	Erase Busy					Erase Susp	Erase Busy		
	Suspend	Erase Suspend	Pgm in Erase Susp Setup	Erase Suspend		Erase Busy	Erase Suspend			
Program in Erase Suspend	Setup	Program in Erase Suspend Busy								
	Busy	Program in Erase Suspend Busy					Pgm Susp in Erase Susp	Program in Erase Suspend Busy		
	Suspend	Program Suspend in Erase Suspend				Pgm in Erase Susp Busy	Program Suspend in Erase Suspend			
Lock/CR Setup in Erase Suspend		Erase Suspend (Lock Error)				Erase Susp	Erase Suspend (Lock Error)			
Enhanced Factory Program	Setup	Ready (Error)				EFP Busy	Ready (Error)			
	EFP Busy	EFP Busy ⁽⁷⁾								
	EFP Verify	Verify Busy ⁽⁷⁾								
Output Next State after Command Input										
Output Next State Table ⁽¹⁾	Pgm Setup, Erase Setup, OTP Setup, Pgm in Erase Susp Setup, EFP Setup, EFP Busy, Verify Busy	Status								
	Lock/CR Setup, Lock/CR Setup in Erase Susp	Status								
	OTP Busy	Status								
	Ready, Pgm Busy, Pgm Suspend, Erase Busy, Erase Suspend, Pgm In Erase Susp Busy, Pgm Susp In Erase Susp	Array ⁽³⁾	Status	Output does not change			Status	Output does not change	ID/Query	

Figure 40: Write State Machine – Next State Table (Sheet 2 of 2)

Chip Next State after Command Input										
Write State Machine (WSM) Next State Table	Current Chip State ⁽⁸⁾	Lock, Unlock, Lock-down, CR setup ⁽⁵⁾ (60H)	OTP Setup ⁽⁵⁾ (C0H)	Lock Block Confirm ⁽⁹⁾ (01H)	Lock-Down Block Confirm ⁽⁹⁾ (2FH)	Write CR Confirm ⁽⁹⁾ (03H)	Enhanced Fact Pgm Exit (blk add <> WA0) (XXXXH)	Illegal commands or EFP data ⁽²⁾ (other codes)	WSM Operation Completes	
	Ready	Lock/CR Setup	OTP Setup	Ready						N/A
	Lock/CR Setup	Ready (Lock Error)		Ready	Ready	Ready	Ready (Lock Error)			
	OTP	Setup	OTP Busy							Ready
		Busy								
	Program	Setup	Program Busy							N/A
		Busy	Program Busy							Ready
		Suspend	Program Suspend							N/A
	Erase	Setup	Ready (Error)							N/A
		Busy	Erase Busy						Erase Busy	Ready
Suspend		Lock/CR Setup in Erase Susp	Erase Suspend					N/A		
Program in Erase Suspend	Setup	Program in Erase Suspend Busy							Erase Suspend	
	Busy	Program in Erase Suspend Busy								
	Suspend	Program Suspend in Erase Suspend								
Lock/CR Setup in Erase Suspend	Erase Suspend (Lock Error)		Erase Susp	Erase Susp	Erase Susp	Erase Suspend (Lock Error)			N/A	
Enhanced Factory Program	Setup	Ready (Error)							Ready	
	EFP Busy	EFP Busy ⁽⁷⁾					EFP Verify	EFP Busy ⁽⁷⁾		
	EFP Verify	Verify Busy ⁽⁷⁾					Ready	EFP Verify ⁽⁷⁾		

Output Next State after Command Input					
Output Next State Table ⁽¹⁾	Pgm Setup, Erase Setup, OTP Setup, Pgm in Erase Susp Setup, EFP Setup, EFP Busy, Verify Busy	Status			Output does not change
	Lock/CR Setup, Lock/CR Setup in Erase Susp	Status	Array	Status	
	OTP Busy				
	Ready, Pgm Busy, Pgm Suspend, Erase Busy, Erase Suspend, Pgm In Erase Susp Busy, Pgm Susp In Erase Susp	Status	Output does not change	Array	

Notes:

- The output state shows the type of data that appears at the outputs if the partition address is the same as the command address.
A partition can be placed in Read Array, Read Status or Read ID/CFI, depending on the command issued. Each partition stays in its last output state (Array, ID/CFI or Status) until a new command changes it. The next WSM state does not depend on the partition's output state.
For example, if partition #1's output state is Read Array and partition #4's output state is Read Status, every read from partition #4 (without issuing a new command) outputs the Status register.
- Illegal commands are those not defined in the command set.

3. All partitions default to Read Array mode at power-up. A Read Array command issued to a busy partition results in undermined data when a partition address is read.
4. Both cycles of 2 cycles commands should be issued to the same partition address. If they are issued to different partitions, the second write determines the active partition. Both partitions will output status information when read.
5. If the WSM is active, both cycles of a 2 cycle command are ignored. This differs from previous Numonyx devices.
6. The Clear Status command clears Status Register error bits except when the WSM is running (Pgm Busy, Erase Busy, Pgm Busy In Erase Suspend, OTP Busy, EFP modes) or suspended (Erase Suspend, Pgm Suspend, Pgm Suspend In Erase Suspend).
7. EFP writes are allowed only when Status Register bit SR.0 = 0. EFP is busy if Block Address = address at EFP Confirm command. Any other commands are treated as data.
8. The "current state" is that of the WSM, not the partition.
9. Confirm commands (Lock Block, Unlock Block, Lock-down Block, Configuration Register) perform the operation and then move to the Ready State.
10. In Erase suspend, the only valid two cycle commands are "Program Word", "Lock/Unlock/Lockdown Block", and "CR Write". Both cycles of other two cycle commands ("OEM CAM program & confirm", "Program OTP & confirm", "EFP Setup & confirm", "Erase setup & confirm") will be ignored. In Program suspend or Program suspend in Erase suspend, both cycles of all two cycle commands will be ignored.

Appendix B Common Flash Interface (CFI)

This appendix defines the data structure or “database” returned by the Common Flash Interface (CFI) Query command. System software should parse this structure to gain critical information such as block size, density, x8/x16, and electrical specifications. Once this information has been obtained, the software will know which command sets to use to enable flash writes, block erases, and otherwise control the flash component. The Query is part of an overall specification for multiple command set and control interface descriptions called Common Flash Interface, or CFI.

B.1 Query Structure Output

The Query database allows system software to obtain information for controlling the flash device. This section describes the device’s CFI-compliant interface that allows access to Query data.

Query data are presented on the lowest-order data outputs (DQ0-7) only. The numerical offset value is the address relative to the maximum bus width supported by the device. On this family of devices, the Query table device starting address is a 10h, which is a word address for x16 devices.

For a word-wide (x16) device, the first two Query-structure bytes, ASCII “Q” and “R,” appear on the low byte at word addresses 10h and 11h. This CFI-compliant device outputs 00h data on upper bytes. The device outputs ASCII “Q” in the low byte (DQ₀₋₇) and 00h in the high byte (DQ₈₋₁₅).

At Query addresses containing two or more bytes of information, the least significant data byte is presented at the lower address, and the most significant data byte is presented at the higher address.

In all of the following tables, addresses and data are represented in hexadecimal notation, so the “h” suffix has been dropped. In addition, since the upper byte of word-wide devices is always “00h,” the leading “00” has been dropped from the table notation and only the lower byte value is shown. Any x16 device outputs can be assumed to have 00h on the upper byte in this mode.

Table 36: Summary of Query Structure Output as a Function of Device and Mode

Device	Hex Offset	Hex Code	ASCII Value
Device Addresses	00010	51	“Q”
	00011	52	“R”
	00012	59	“Y”

Table 37: Example of Query Structure Output of x16 Device

Word Addressing			Byte Addressing		
Offset	Hex Code	Value	Offset	Hex Code	Value
A _x - A ₀	D ₁₆ - D ₀		A _x - A ₀	D ₇ - D ₀	
00010h	0051	"Q"	00010h	51	"Q"
00011h	0052	"R"	00011h	52	"R"
00012h	0059	"Y"	00012h	59	"Y"
00013h	P ID _{LO}	P rVendor	00013h	P ID _{LO}	P rVendor
00014h	P ID _{HI}	ID #	00014h	P ID _{LO}	ID #
00015h	P _{LO}	P rVendor	00015h	P ID _{HI}	ID #
00016h	P _{HI}	TblAdr	00016h
00017h	A ID _{LO}	AltVendor	00017h
00018h	A ID _{HI}	ID #	00018h

B.2 Query Structure Overview

The Query command causes the flash component to display the Common Flash Interface (CFI) Query structure or "database." The structure sub-sections and address locations are summarized below.

Table 38: Query Structure

Offset	Sub-Section Name	Description ⁽¹⁾
00000h		Manufacturer Code
00001h		Device Code
(BA+2)h ⁽²⁾	Block Status register	Block-specific information
00004-Fh	Reserved	Reserved for vendor-specific information
00010h	CFI query identification string	Command set ID and vendor data offset
0001Bh	System interface information	Device timing & voltage information
00027h	Device geometry definition	Flash device layout
P ⁽³⁾	Primary Intel-specific Extended Query Table	Vendor-defined additional information specific to the Primary Vendor Algorithm

Notes:

1. Refer to the Query Structure Output section and offset 28h for the detailed definition of offset address as a function of device bus width and mode.
2. BA = Block Address beginning location (i.e., 08000h is block 1's beginning location when the block size is 32K-word).
3. Offset 15 defines "P" which points to the Primary Numonyx-specific Extended Query Table.

B.3 Block Status Register

The Block Status Register indicates whether an erase operation completed successfully or whether a given block is locked or can be accessed for flash program/erase operations.

Block Erase Status (BSR.1) allows system software to determine the success of the last block erase operation. BSR.1 can be used just after power-up to verify that the VCC supply was not accidentally removed during an erase operation.

Table 39: Block Status Register

Offset	Length	Description	Add.	Value
(BA+2)h ⁽¹⁾	1	Block Lock Status Register	BA+2	--00 or --01
		BSR.0 Block lock status 0 = Unlocked 1 = Locked	BA+2	(bit 0): 0 or 1
		BSR.1 Block lock-down status 0 = Not locked down 1 = Locked down	BA+2	(bit 1): 0 or 1
		BSR 2-7: Reserved for future use	BA+2	(bit 2-7): 0

Notes:

1. BA = Block Address beginning location (i.e., 08000h is block 1's beginning location when the block size is 32K-word).

B.4 CFI Query Identification String

The Identification String provides verification that the component supports the Common Flash Interface specification. It also indicates the specification version and supported vendor-specified command set(s).

Table 40: CFI Identification

Offset	Length	Description	Addr.	Hex Code	Value
10h	3	Query-unique ASCII string "QRY"	10: 11: 12:	--51 --52 --59	"Q" "R" "Y"
13h	2	Primary vendor command set and control interface ID code. 16-bit ID code for vendor-specific algorithms.	13: 14:	--03 --00	—
15h	2	Extended Query Table primary algorithm address	15: 16:	--39 --00	—
17h	2	Alternate vendor command set and control interface ID code. 0000h means no second vendor-specified algorithm exists.	17: 18:	--00 --00	—
19h	2	Secondary algorithm Extended Query Table address. 0000h means none exists.	19: 1A:	--00 --00	—

Table 41: System Interface Information

Offset	Length	Description	Addr.	Hex Code	Value
1Bh	1	V _{CC} logic supply minimum program/erase voltage bits 0–3 BCD 100 mV bits 4–7 BCD volts	1B:	–17	1.7V
1Ch	1	V _{CC} logic supply maximum program/erase voltage bits 0–3 BCD 100 mV bits 4–7 BCD volts	1C:	–19	1.9V
1Dh	1	V _{PP} [programming] supply minimum program/erase voltage bits 0–3 BCD 100 mV bits 4–7 HEX volts	1D:	–B4	11.4V
1Eh	1	V _{PP} [programming] supply maximum program/erase voltage bits 0–3 BCD 100 mV bits 4–7 HEX volts	1E:	–C6	12.6V
1Fh	1	"n" such that typical single word program time-out = 2 ⁿ μ-sec	1F:	–04	16μs
20h	1	"n" such that typical max. buffer write time-out = 2 ⁿ μ-sec	20:	–00	NA
21h	1	"n" such that typical block erase time-out = 2 ⁿ m-sec	21:	–0A	1s
22h	1	"n" such that typical full chip erase time-out = 2 ⁿ m-sec	22:	–00	NA
23h	1	"n" such that maximum word program time-out = 2 ⁿ times typical	23:	–04	256μs
24h	1	"n" such that maximum buffer write time-out = 2 ⁿ times typical	24:	–00	NA
25h	1	"n" such that maximum block erase time-out = 2 ⁿ times typical	25:	–03	8s
26h	1	"n" such that maximum chip erase time-out = 2 ⁿ times typical	26:	–00	NA

B.5 Device Geometry Definition

Table 42: Device Geometry Definition

Offset	Length	Description	Code																		
27h	1	"n" such that device size = 2 ⁿ in number of bytes	27:	See table below																	
28h	2	Flash device interface code assignment: "n" such that n+1 specifies the bit field that represents the flash device width capabilities as described in the table:	28:	--01	x16																
		<table border="1" style="width: 100%; text-align: center;"> <tr> <td>7</td><td>6</td><td>5</td><td>4</td><td>3</td><td>2</td><td>1</td><td>0</td> </tr> <tr> <td>—</td><td>—</td><td>—</td><td>—</td><td>x64</td><td>x32</td><td>x16</td><td>x8</td> </tr> </table>				7	6	5	4	3	2	1	0	—	—	—	—	x64	x32	x16	x8
		7				6	5	4	3	2	1	0									
—	—	—	—	x64	x32	x16	x8														
<table border="1" style="width: 100%; text-align: center;"> <tr> <td>15</td><td>14</td><td>13</td><td>12</td><td>11</td><td>10</td><td>9</td><td>8</td> </tr> <tr> <td>—</td><td>—</td><td>—</td><td>—</td><td>—</td><td>—</td><td>—</td><td>—</td> </tr> </table>	15	14	13	12	11	10	9	8	—	—	—	—	—	—	—	—					
15	14	13	12	11	10	9	8														
—	—	—	—	—	—	—	—														
29:	--00																				
2Ah	2	"n" such that maximum number of bytes in write buffer = 2 ⁿ	2A: 2B:	--00 --00	0																
2Ch	1	Number of erase block regions (x) within device: 1. x = 0 means no erase blocking; the device erases in bulk 2. x specifies the number of device regions with one or more contiguous same-size erase blocks. 3. Symmetrically blocked partitions have one blocking region	2C:	See table below																	
2Dh	4	Erase Block Region 1 Information bits 0–15 = y, y+1 = number of identical-size erase blocks bits 16–31 = z, region erase block(s) size are z x 256 bytes	2D: 2E: 2F: 30:	See table below																	
31h	4	Erase Block Region 2 Information bits 0–15 = y, y+1 = number of identical-size erase blocks bits 16–31 = z, region erase block(s) size are z x 256 bytes	31: 32: 33: 34:	See table below																	
35h	4	Reserved for future erase block region information	35: 36: 37: 38:	See table below																	

Address	32 Mbit		64 Mbit		128 Mbit	
	-B	-T	-B	-T	-B	-T
27:	--16	--16	--17	--17	--18	--18
28:	--01	--01	--01	--01	--01	--01
29:	--00	--00	--00	--00	--00	--00
2A:	--00	--00	--00	--00	--00	--00
2B:	--00	--00	--00	--00	--00	--00
2C:	--02	--02	--02	--02	--02	--02
2D:	--07	--3E	--07	--7E	--07	--FE
2E:	--00	--00	--00	--00	--00	--00
2F:	--20	--00	--20	--00	--20	--00
30:	--00	--01	--00	--01	--00	--01
31:	--3E	--07	--7E	--07	--FE	--07
32:	--00	--00	--00	--00	--00	--00
33:	--00	--20	--00	--20	--00	--20
34:	--01	--00	--01	--00	--01	--00
35:	--00	--00	--00	--00	--00	--00
36:	--00	--00	--00	--00	--00	--00
37:	--00	--00	--00	--00	--00	--00
38:	--00	--00	--00	--00	--00	--00

Table 44: Protection Register Information

Offset P = 39h	Length	Description (Optional Flash Features and Commands)	Add.	Hex Code	Value
(P + E)h	1	Number of Protection Register fields in JEDEC ID space. "00h" indicates that 256 protection fields are available.	47:	--01	1
(P + E)h (P + 10)h (P + 11)h (P + 12)h	4	<p>Protection Field 1: Protection Description</p> <p>This field describes user-available One Time Programmable (OTP) Protection Register bytes. Some are pre-programmed with device-unique serial numbers. Others are user-programmable. Bits are 0-15 point to the Protection Register lock byte, the section's first byte. The following bytes are factory pre-programmed and user-programmable:</p> <ul style="list-style-type: none"> bits 0-7 = Lock/bytes JEDEC-plane physical low address bits 8-15 = Lock/bytes JEDEC-plane physical high address bits 16-23 = "n" such that 2n = factory pre-programmed bytes bits 24-31 = "n" such that 2n = user-programmable bytes 	48: 49: 4A: 4B:	--80 --00 --03 --03	80h 00h 8 byte 8 byte

Table 45: Burst Read Information for Non-muxed Device

Offset ⁽¹⁾ P = 39h	Length	Description (Optional flash features and commands)	Add.	Hex Code	Value
(P+13)h	1	Page Mode Read capability bits 0-7 = "n" such that 2 ⁿ HEX value represents the number of read-page bytes. See offset 28h for device word width to determine page-mode data output width. 00h indicates no read page buffer.	4C:	--03	8 byte
(P+14)h	1	Number of synchronous mode read configuration fields that follow. 00h indicates no burst capability.	4D:	--04	4
(P+15)h	1	Synchronous mode read capability configuration 1 Bits 3-7 = Reserved bits 0-2 "n" such that 2 ⁿ⁺¹ HEX value represents the maximum number of continuous synchronous reads when the device is configured for its maximum word width. A value of 07h indicates that the device is capable of continuous linear bursts that will output data until the internal burst counter reaches the end of the device's burstable address space. This field's 3-bit value can be written directly to the Read Configuration Register bits 0-2 if the device is configured for its maximum word width. See offset 28h for word width to determine the burst data output width.	4E:	--01	4
(P+16)h	1	Synchronous mode read capability configuration 2	4F:	--02	8
(P+17)h	1	Synchronous mode read capability configuration 3	50:	--03	16
(P+18)h	1	Synchronous mode read capability configuration 4	51:	--07	Cont

Table 46: Partition and Erase-block Region Information

Offset ⁽¹⁾ P = 39h		Description (Optional flash features and commands)	See table below		
Bottom	Top		Len	Address	
				Bot	Top
(P+19)h	(P+19)h	Number of device hardware-partition regions within the device. x = 0: a single hardware partition device (no fields follow). x specifies the number of device partition regions containing one or more contiguous erase block regions.	1	52:	52:

Table 47: Partition Region 1 Information

Offset ⁽¹⁾ P = 39h		Description (Optional flash features and commands)	See table below		
Bottom	Top		Len	Address	
				Bot	Top
(P+1A)h (P+1B)h	(P+1A)h (P+1B)h	Number of identical partitions within the partition region	2	53: 54:	53: 54:
(P+1C)h	(P+1C)h	Number of program or erase operations allowed in a partition bits 0–3 = number of simultaneous Program operations bits 4–7 = number of simultaneous Erase operations	1	55:	55:
(P+1D)h	(P+1D)h	Simultaneous program or erase operations allowed in other partitions while a partition in this region is in Program mode bits 0–3 = number of simultaneous Program operations bits 4–7 = number of simultaneous Erase operations	1	56:	56:
(P+1E)h	(P+1E)h	Simultaneous program or erase operations allowed in other partitions while a partition in this region is in Erase mode bits 0–3 = number of simultaneous Program operations bits 4–7 = number of simultaneous Erase operations	1	57:	57:
(P+1F)h	(P+1F)h	Types of erase block regions in this Partition Region. x = 0 = no erase blocking; the Partition Region erases in bulk x = number of erase block regions w/ contiguous same-size erase blocks. Symmetrically blocked partitions have one blocking region. Partition size = (Type 1 blocks)x(Type 1 block sizes) + (Type 2 blocks)x(Type 2 block sizes) + ... + (Type n blocks)x(Type n block sizes)	1	58:	58:
(P+20)h (P+21)h (P+22)h (P+23)h	(P+20)h (P+21)h (P+22)h (P+23)h	Partition Region 1 Erase Block Type 1 Information bits 0–15 = y, y+1 = number of identical-size erase blocks bits 16–31 = z, region erase block(s) size are z x 256 bytes	4	59: 5A: 5B: 5C:	59: 5A: 5B: 5C:
(P+24)h (P+25)h	(P+24)h (P+25)h	Partition 1 (Erase Block Type 1) Minimum block erase cycles x 1000	2	5D: 5E:	5D: 5E:
(P+26)h	(P+26)h	Partition 1 (erase block Type 1) bits per cell; internal ECC bits 0–3 = bits per cell in erase region bit 4 = reserved for “internal ECC used” (1=yes, 0=no) bits 5–7 = reserve for future use	1	5F:	5F:
(P+27)h	(P+27)h	Partition 1 (erase block Type 1) page mode and synchronous mode capabilities defined in Table 10. bit 0 = page-mode host reads permitted (1=yes, 0=no) bit 1 = synchronous host reads permitted (1=yes, 0=no) bit 2 = synchronous host writes permitted (1=yes, 0=no) bits 3–7 = reserved for future use	1	60:	60:
(P+28)h (P+29)h (P+2A)h (P+2B)h		Partition Region 1 Erase Block Type 2 Information bits 0–15 = y, y+1 = number of identical-size erase blocks bits 16–31 = z, region erase block(s) size are z x 256 bytes (bottom parameter device only)	4	61: 62: 63: 64:	
(P+2C)h (P+2D)h		Partition 1 (Erase block Type 2) Minimum block erase cycles x 1000	2	65: 66:	
(P+2E)h		Partition 1 (Erase block Type 2) bits per cell bits 0–3 = bits per cell in erase region bit 4 = reserved for “internal ECC used” (1=yes, 0=no) bits 5–7 = reserve for future use	1	67:	
(P+2F)h		Partition 1 (Erase block Type 2) pagemode and synchronous mode capabilities defined in Table 10 bit 0 = page-mode host reads permitted (1=yes, 0=no) bit 1 = synchronous host reads permitted (1=yes, 0=no) bit 2 = synchronous host writes permitted (1=yes, 0=no) bits 3–7 = reserved for future use	1	68:	

Table 48: Partition and Erase Block Region Information

Address	32 Mbit		64Mbit		128Mbit	
	-B	-T	-B	-T	-B	-T
52:	--02	--02	--02	--02	--02	--02
53:	--01	--07	--01	--0F	--01	--1F
54:	--00	--00	--00	--00	--00	--00
55:	--11	--11	--11	--11	--11	--11
56:	--00	--00	--00	--00	--00	--00
57:	--00	--00	--00	--00	--00	--00
58:	--02	--01	--02	--01	--02	--01
59:	--07	--07	--07	--07	--07	--07
5A:	--00	--00	--00	--00	--00	--00
5B:	--20	--00	--20	--00	--20	--00
5C:	--00	--01	--00	--01	--00	--01
5D:	--64	--64	--64	--64	--64	--64
5E:	--00	--00	--00	--00	--00	--00
5F:	--01	--01	--01	--01	--01	--01
60:	--03	--03	--03	--03	--03	--03
61:	--06	--01	--06	--01	--06	--01
62:	--00	--00	--00	--00	--00	--00
63:	--00	--11	--00	--11	--00	--11
64:	--01	--00	--01	--00	--01	--00
65:	--64	--00	--64	--00	--64	--00
66:	--00	--02	--00	--02	--00	--02
67:	--01	--06	--01	--06	--01	--06
68:	--03	--00	--03	--00	--03	--00
69:	--07	--00	--0F	--00	--1F	--00
6A:	--00	--01	--00	--01	--00	--01
6B:	--11	--64	--11	--64	--11	--64
6C:	--00	--00	--00	--00	--00	--00
6D:	--00	--01	--00	--01	--00	--01
6E:	--01	--03	--01	--03	--01	--03
6F:	--07	--07	--07	--07	--07	--07
70:	--00	--00	--00	--00	--00	--00
71:	--00	--20	--00	--20	--00	--20
72:	--01	--00	--01	--00	--01	--00
73:	--64	--64	--64	--64	--64	--64
74:	--00	--00	--00	--00	--00	--00
75:	--01	--01	--01	--01	--01	--01
76:	--03	--03	--03	--03	--03	--03

Notes:

1. The variable P is a pointer which is defined at CFI offset 15h.
2. TPD - Top parameter device; BPD - Bottom parameter device.
3. Partition: Each partition is 4-Mbit in size. It can contain main blocks OR a combination of both main and parameter blocks.
4. Partition Region: Symmetrical partitions form a partition region. There are two partition regions: A contains all the partitions that are made up of main blocks only; B contains the partition made up of the parameter and the main blocks.

Appendix C Ordering Information

To order samples, obtain datasheets or inquire about any stack combination, please contact your local Numonyx representative.

Table 49: 38F Type Stacked Components

PF	38F	5070	M0	Y	0	B	0
Package Designator	Product Line Designator	Product Die/ Density Configuration	NOR Flash Product Family	Voltage/NOR Flash CE# Configuration	Parameter / Mux Configuration	Ballout Identifier	Device Details
PF = SCSP, RoHS RD = SCSP, Leaded	Stacked NOR Flash + RAM	Char 1 = Flash die #1 Char 2 = Flash die #2 Char 3 = RAM die #1 Char 4 = RAM die #2 (See Table 51, "38F/48F Density Decoder" on page 100 for details)	First character applies to Flash die #1 Second character applies to Flash die #2 (See Table 52, "NOR Flash Family Decoder" on page 101 for details)	V = 1.8 V Core and I/O; Separate Chip Enable per die (See Table 53, "Voltage / NOR Flash CE# Configuration Decoder" on page 101 for details)	0 = No parameter blocks; Non-Mux I/O interface (See Table 54, "Parameter / Mux Configuration Decoder" on page 101 for details)	B = x16D Ballout (See Table 55, "Ballout Decoder" on page 102 for details)	0 = Original released version of this product

Table 50: 48F Type Stacked Components

PC	48F	4400	P0	V	B	0	0
Package Designator	Product Line Designator	Product Die/ Density Configuration	NOR Flash Product Family	Voltage/NOR Flash CE# Configuration	Parameter / Mux Configuration	Ballout Identifier	Device Details
PC = Easy BGA, RoHS RC = Easy BGA, Leaded JS = TSOP, RoHS TE = TSOP, Leaded PF = SCSP, RoHS RD = SCSP, Leaded	Stacked NOR Flash only	Char 1 = Flash die #1 Char 2 = Flash die #2 Char 3 = Flash die #3 Char 4 = Flash die #4 (See Table 51, "38F / 48F Density Decoder" on page 100 for details)	First character applies to Flash dies #1 and #2 Second character applies to Flash dies #3 and #4 (See Table 52, "NOR Flash Family Decoder" on page 101 for details)	V = 1.8 V Core and 3 V I/O; Virtual Chip Enable (See Table 53, "Voltage / NOR Flash CE# Configuration Decoder" on page 101 for details)	B = Bottom parameter; Non-Mux I/O interface (See Table 54, "Parameter / Mux Configuration Decoder" on page 101 for details)	0 = Discrete Ballout (See Table 55, "Ballout Decoder" on page 102 for details)	0 = Original released version of this product

Table 51: 38F / 48F Density Decoder

Code	Flash Density	RAM Density
0	No Die	No Die
1	32-Mbit	4-Mbit
2	64-Mbit	8-Mbit
3	128-Mbit	16-Mbit
4	256-Mbit	32-Mbit
5	512-Mbit	64-Mbit
6	1-Gbit	128-Mbit
7	2-Gbit	256-Mbit
8	4-Gbit	512-Mbit
9	8-Gbit	1-Gbit
A	16-Gbit	2-Gbit
B	32-Gbit	4-Gbit
C	64-Gbit	8-Gbit
D	128-Gbit	16-Gbit
E	256-Gbit	32-Gbit
F	512-Gbit	64-Gbit

Table 52: NOR Flash Family Decoder

Code	Family	Marketing Name
C	C3	Numonyx Advanced+ Boot Block Flash Memory
J	J3v.D	Numonyx Embedded Flash Memory
L	L18 / L30	Numonyx StrataFlash® Wireless Memory
M	M18	Numonyx StrataFlash® Cellular Memory
P	P30 / P33	Numonyx StrataFalsh® Embedded Memory
W	W18 / W30	Numonyx Wireless Flash Memory
0(zero)	-	No Die

Table 53: Voltage / NOR Flash CE# Configuration Decoder

Code	I/O Voltage (Volt)	Core Voltage (Volt)	CE# Configuration
Z	3.0	1.8	Seperate Chip Enable per die
Y	1.8	1.8	Seperate Chip Enable per die
X	3.0	3.0	Seperate Chip Enable per die
V	3.0	1.8	Virtual Chip Enable
U	1.8	1.8	Virtual Chip Enable
T	3.0	3.0	Virtual Chip Enable
R	3.0	1.8	Virtual Address
Q	1.8	1.8	Virtual Address
P	3.0	3.0	Virtual Address

Table 54: Parameter / Mux Configuration Decoder

Code, Mux Identification	Number of Flash Die	Bus Width	Flash Die 1	Flash Die 2	Flash Die 3	Flash Die 4
0 = Non Mux 1 = AD Mux ¹ 2 = AAD Mux 3 = "Full" AD Mux ²	Any	NA	Notation used for stacks that contain no parameter blocks			
B = Non Mux C = AD Mux F = "Full" Ad Mux	1	X16	Bottom	-	-	-
	2		Bottom	Top	-	-
	3		Bottom	Bottom	Top	-
	4		Bottom	Top	Bottom	Top
	2	X32	Bottom	Bottom	-	-
	4		Bottom	Bottom	Top	Top

Table 54: Parameter / Mux Configuration Decoder

Code, Mux Identification	Number of Flash Die	Bus Width	Flash Die 1	Flash Die 2	Flash Die 3	Flash Die 4
T = Non Mux U = AD Mux W = "Full" Ad Mux	1	X16	Top	-	-	-
	2		Top	Bottom	-	-
	3		Top	Top	Bottom	-
	4		Top	Bottom	Top	Bottom
	2	X32	Top	Top	-	-
	4		Top	Top	Bottom	Bottom

1. Only Flash is Muxed and RAM is non-Muxed
2. Both Flash and RAM are AD-Muxed

Table 55: Ballout Decoder

Code	Ballout Definition
0 (Zero)	SDiscrete ballout (Easay BGA and TSOP)
B	x16D ballout, 105 ball (x16 NOR + NAND + DRAM Share Bus)
C	x16C ballout, 107 ball (x16 NOR + NAND + PSRAM Share Bus)
Q	QUAD/+ ballout, 88 ball (x16 NOR + PSRAM Share Bus)
U	x32SH ballout, 106 ball (x32 NOR only Share Bus)
V	x16SB ballout, 165 ball (x16 NOR / NAND + x16 DRAM Split Bus)
W	x48D ballout, 165 ball (x16/x32 NOR + NAND + DRAM Split Bus)